



BESTOBELLSTEAM



STEAM TRAPS & STEAM SPECIALTIES PRODUCT OVERVIEW



INTRODUCTION

Bestobell Steam created the unique Delta Element steam trap to correct two steam trap problems that cause lost profit: steam loss and trap failure. Simply put, we wanted to create a steam trap that outlived the boiler and did what the name implies . . . trap steam . . . and remove condensate. Traditional trap technologies have inherent flaws that reduce your profit.

Why correct these problems? *They cost you profit!* Inherent steam loss and trap failure steam loss not only cost you utility dollars, but increase O & M expense and interrupt the production of quality product.

Since then, Bestobell has expanded its' expertise and now offers a complete line of steam system solutions, including steam traps, float & thermostatic traps, thermodynamic disc traps, leak detectors, condensate return pumps, line strainers, as well as a host of complementary steam specialty products. Whether in the market for low pressure tracing lines, high pressure process applications or reliable heat exchangers, Bestobell has the solution and guarantees three years operation with no live steam loss on all Delta Element Steam Traps.



DELTA ELEMENT STEAM TRAPS

- » Long-term, trouble-free service due to single blade element, stainless steel internals, built-in strainer and check valve
- » Only 30-40% of total pressure drop occurs over seating surface resulting in long valve life
- » Problems due to cyclic discharge are eliminated with modulating discharge
- » High cold discharge capacities provide fast start-up capabilities
- » Excellent heat transfer and minimum corrosion by continuous air and CO₂ venting

STEAM TRAPS

- » Disc traps - compact, lightweight, thermodynamic style disc traps with working pressures up to 711 psi
- » Clean steam traps - designed specifically for clean steam systems, a bellows type, thermostatic steam trap
- » Capsule traps - small and lightweight thermostatic design provides good discharge of condensate and non-condensate gases

INVERTED BUCKET TRAPS

- » Unique linkage system provides for maximum flow capacities
- » Increased trap life and minimal impact from corrosion is achieved by hardened stainless steel valve and seat
- » Reliable and industry-accepted design for applications where cyclic design is desirable

FLOAT & THERMOSTATIC TRAPS

- » Enhanced sensitivity to pressure and temperature conditions
- » Continuous condensate discharge
- » Maximum heat transfer is provided by separate internal air and CO₂ venting
- » Easy in-line inspection and repair. Removable flush plug permits easy cleaning

TOTAL TRAPS

- » One-piece, self-contained total steam trap station
- » Disc trap with replaceable cartridge, disc and cap
- » Strainer
- » Installation requires only 2 welds and less than 14" of space end-to-end
- » Optional modular Grayloc-style ends

DELTA ELEMENT STEAM TRAPS

A sophisticated, yet simple, design that will provide years of trouble-free service with no live steam loss.

Bestobell Steam's Delta Element is a triangular shaped bimetal strip of joined austenitic and ferritic stainless steels. It assures strong, consistent, and repeatable operation over the life of the trap. This bonded steel is processed for additional strength, shaped into the delta element pattern and heat-treated to eliminate stresses. The process allows the Bestobell Delta Element traps long life with consistent operation.

The single blade design provides faster response due to the large surface/mass ratio. The stem is situated at a point that allows the expansion of the bimetal to exert a linear pull on the stem to prevent uneven wear on the sealing surfaces.

Bestobell Delta Element traps employ a hybrid design utilizing both thermostatic and thermodynamic principles to achieve a continuous modulating discharge of condensate as it forms, eliminating live steam loss.

The combination of a temperature-sensitive closing force (thermostatic element) and a pressure-sensitive opening force (thermodynamic valve) overcome the sluggishness and susceptibility to service failure encountered with traditional bimetallic designs. The valve design utilizes the thermodynamic pressure forces of the flashing steam to provide quick response and a wide operating range closely approximating the steam curve.

Bestobell Steam saves you the added expense of buying and installing separate strainers and check valves to complete your steam trap station. Most models include a built-in strainer to protect the trap internals in your steam system and the valve stem acts as an integral check valve to prevent backward flow of condensate. The Delta Element trap can operate in applications with constant back pressure of up to 70% of inlet pressures due to the adjustable design on the element.

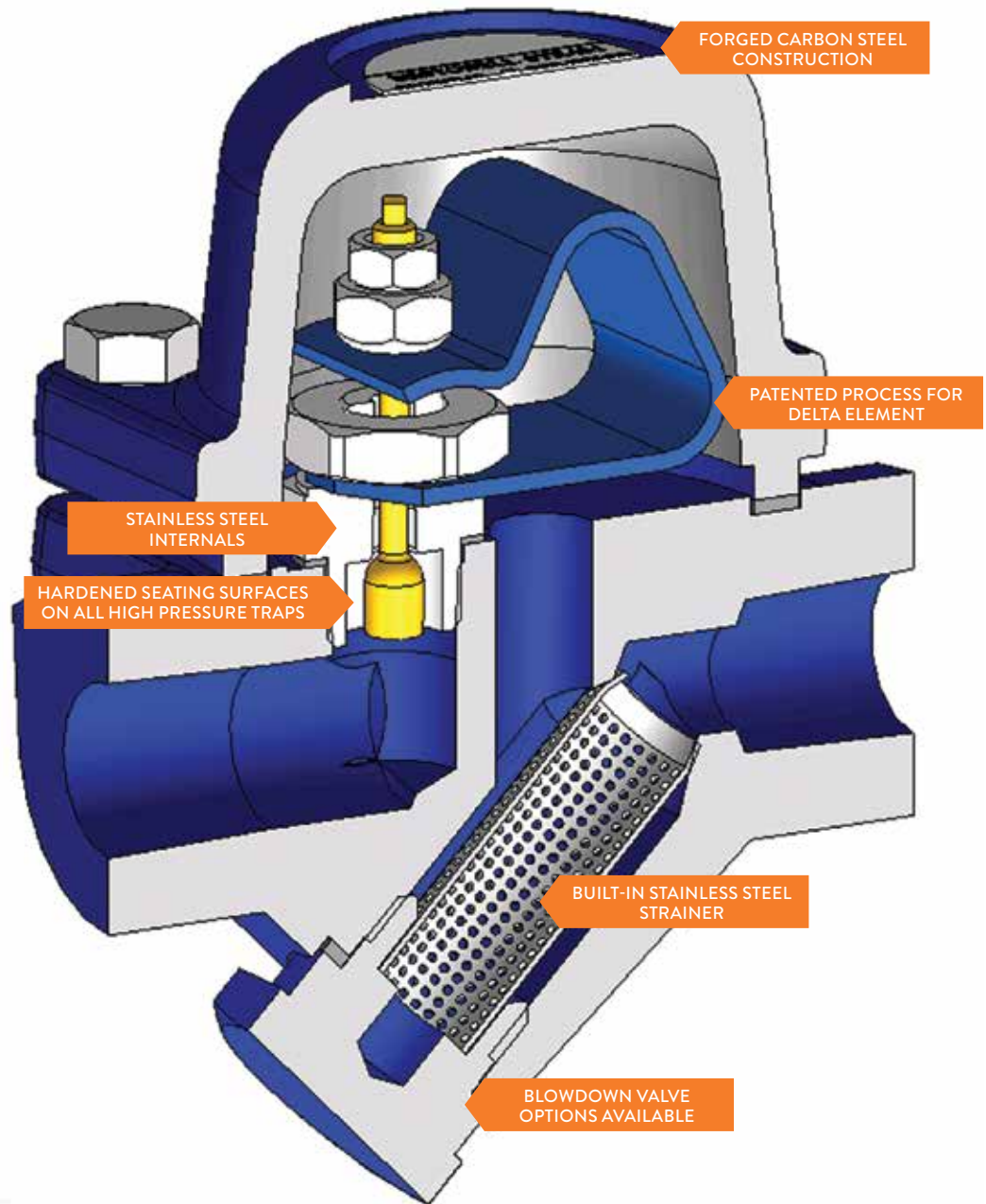

3 YEAR WARRANTY

For greater energy efficiency and long seat life, the Bestobell Delta Element is warranted up to three years against the loss of live steam in operation (up to 320 psi/22 bar)



UNIVERSAL MOUNT

An inline universal mount is available with or without an integral strainer



INSTALLATION

The Delta Element steam trap is effective mounted either horizontally or vertically



ENERGY EFFICIENT

Delta Element traps allow the process to use more heat energy from both the steam and condensate



DM10E

Freeze Protection & Drainage, Tracer (sub-cooled)

Commonly used as an automatic drain for freeze-proof protection of condensate return systems and manifold, and on tracer systems where maximum use of BTU's from condensate is desired.

Sizes	3/8", 1/2", 3/4"
Body Material	Carbon Steel
Max Allowable Pressure	750 psi (51,7 bar)

DM25

Drain & Tracer

For use on a steam main dripleg and critical tracing service with operating pressures up to 320 psig (22,0 bar). The single blade element offers long-term, trouble-free service because it's not prone to dirt build-up.

Sizes	1/2" & 3/4"
Body Material	Carbon Steel
Max Allowable Pressure	750 psi (51,7 bar)



DM40/64/100/160/320

High Pressure

An excellent choice for high pressure applications, these rugged steam traps provide fast start-up and high performance on steam main driplegs and pressure process applications with operating pressure ranges from 250 psi (17,2 bar) to 2000 psi (138 bar).

Sizes	1/2", 3/4", 1"
Body Material	DM40 & DM64 : Carbon Steel; DM100: Carbon Steel & CrMo; DM160 & DM320 : CrMo
Max Allowable Pressure	DM40: 750 psi (51,7 bar); DM64 & DM100: 1500 psi (103 bar); DM160 & DM320: 2400 psi (166 bar)

DM6/DM12

Drain & Tracer

A line of lightweight, yet rugged, steam traps that provide modulating discharge of light condensate loads without the loss of live steam. These fully maintainable steam traps feature energy-efficient operation with excellent start-up capacities.

Sizes	3/8", 1/2", 3/4"
Body Material	Carbon Steel
Max Allowable Pressure	750 psi (51,7 bar)





DS12

Drain & Tracer

A lightweight steam trap for plant applications requiring sealed Stainless Steel construction for tracing services with operating pressures up to 150 psi (10,3 bar).

Sizes	1/2", 3/4"
Body Material	Investment cast Stainless Steel
Max Allowable Pressure	500 psi (34,5 bar)

M10/GM10

Process & Space Heating

Designed to handle varying loads of process applications and provide fast start-up and modulating discharge with no live steam loss on services up to 120 psi (8,3 bar) operating pressure.

Sizes	M10: 3/8", 1/2", 3/4"; GM10: 1/2", 3/4", 1", 1-1/2", 2"
Body Material	Carbon Steel
Max Allowable Pressure	750 psi (51,7 bar)



M16/GM16

Process & Space Heating

A series of steam traps designed to handle the varying loads on process applications and provide fast start-up and modulating service with no live steam loss.

Sizes	M16: 1/2", 3/4", 1", 1-1/2", 2"; GM16: 1/2", 3/4"
Body Material	Carbon Steel
Max Allowable Pressure	750 psi (51,7 bar)

M22/TM22

Tracer (sub-cooled)

Specifically developed to make use of the latent heat of steam and the sensible heat of condensate prior to discharge. For tracing services with differential pressures up to 300 psi (20,7 bar), these traps are completely maintainable.

Sizes	3/8", 1/2", 3/4"
Body Material	Carbon Steel
Max Allowable Pressure	750 psi (51,7 bar)





M25/GM25

Process & Space Heating

A series of compact, high capacity steam traps developed to handle the varying loads and pressures typical of process and heating applications with operating pressures to 320 psi (22,1 bar).

Sizes	M25: 1/2", 3/4", 1", 1-1/2", 2"; GM25: 1/2", 3/4"
Body Material	Carbon Steel
Max Allowable Pressure	750 psi (51,7 bar)

M3A/GM3

Process & Space Heating

A series of steam traps designed for fast start-up and modulating discharge with no live steam loss on service up to 30 psig differential. They are ideal where a forged body with "Y" type strainer is required to handle light condensate loads including low pressure driplegs.

Sizes	M3A: 3/8", 1/2", 3/4"; GM3: 1/2", 3/4", 1-1/4", 1-1/2", 2"
Body Material	Carbon Steel
Max Allowable Pressure	750 psi (51,7 bar)



M40/M64/M100

High Pressure

A series of heavy duty steam traps designed specifically for high pressure, high flow process applications. Featuring built-in "Y" type strainers and check valves, this series can be used for services operating pressures up to 900 psi (62 bar).

Sizes	1-1/2", 2"
Body Material	Carbon Steel
Max Allowable Pressure	1500 psi (103 bar)

M6A/GM6

Process & Space Heating

A series of steam traps designed for low condensate capacity needs which incorporates a forged carbon steel body and "Y" type strainer. They utilize thermostatic and thermodynamic forces for steam-tight shutoff for greater energy efficiency and extended seat life.

Sizes	M6A: 3/8", 1/2", 3/4"; GM6: 1/2", 3/4", 1", 1-1/4", 1-1/2", 2"
Body Material	Carbon Steel
Max Allowable Pressure	750 psi (51,7 bar)





MAGNUM

Process & Space Heating

A versatile line of high capacity steam traps that can be supplied with up to 18 bimetallic elements for hot condensate flows as high as 149,000 pounds per hour. Five models available for operating pressures up to 320 psig (22 bar).

Sizes	1-1/2", 2", 2-1/2", 3", 4", 6", 8"
Body Material	Carbon Steel
Max Allowable Pressure	750 psi (51,7 bar)

TS22

Tracer (sub-cooled)

For services with operating pressures up to 300 psig (20,7 bar), this model is designed to efficiently make use of the sensible heat by retaining condensate within the tracer line.

Sizes	3/8", 1/2", 3/4"
Body Material	Investment cast Stainless Steel
Max Allowable Pressure	500 psi (34,5 bar)



UNIVERSAL

Universal Mount

A universal mount, bimetallic steam trap is offered for plant applications requiring standardized connections. The universal mounting connections allow trap use on any manufacturer's universal mount. The two bolt replacement is easy to install, replace or rebuild.

Sizes	1/2", 3/4", 1"
Body Material	Stainless Steel
Max Allowable Pressure	650 psi (44,8 bar)



STEAM TRAPS

Along with the Delta Element steam traps, Bestobell also offers thermodynamic disc traps, sanitary clean steam traps and capsule traps.

Bestobell offers two types of disc traps: The DT711 Series which is compact, lightweight and has working pressures up to 711 psi and the DTCS Series which is a non-sanitary trap that offers better corrosion resistance than other thermodynamic traps.

The BTCS Series is a sanitary steam trap designed specifically for clean steam systems. It features a 20Ra internal finish and a self draining design to minimize the possibility of medium entrapment and bacterial growth.

Bestobell offers two types of capsule traps, an all stainless steel construction with a built-in strainer and a forged carbon steel body with built-in Y strainer. Both are ideal for use in or around harsh environments.



DT711

Superheat Disc Trap

The DT711 Series is a line of compact, lightweight, thermodynamic style disc traps designed to efficiently discharge condensate on applications with working pressures up to 711 psi. Available with or without an integral strainer. NPT ends are standard, BSP ends available.

Sizes	3/8", 1/2", 3/4", 1"
Body Material	Stainless Steel casting
Max Allowable Pressure	711 psi (49 bar)

DTCS

Disc Traps

The DTCS is a non-sanitary trap constructed of 316L stainless steel and Tri-Clamp end connections that offers better corrosion resistance than other thermodynamic traps. It meets the requirements of quick response applications in the steam system.

Sizes	1/2", 3/4"
Body Material	Stainless Steel
Max Allowable Pressure	227 psi (15,6 bar)



BTCS

Clean Steam Traps

The BTCS Series is a bellows type, thermostatic steam trap with sanitary connections. Designed specifically for clean steam systems, it features a 20Ra internal finish, and a self-draining design to minimize the possibility of medium entrapment and bacterial growth.

Sizes	1/2", 3/4", 1"
Body Material	316L Stainless Steel
Max Allowable Pressure	145 psi (10,0 bar)

GCM/GSM

Capsule Traps

The GCM and GSM Series are capsule traps with a built-in strainer for use in or around harsh environments. The trap may be disassembled for thermal capsule replacement or inspection of strainer.

Sizes	3/8", 1/2", 3/4", 1"
Body Material	GCM: Forged Carbon Steel; GSM: Stainless Steel
Max Allowable Pressure	580 psi (40 bar)





INVERTED BUCKET TRAPS

Inverted bucket traps rely on the density difference between steam and water to drain condensate as it forms. An inverted bucket floats in condensate that surrounds the bucket. As the bucket moves up and down in the condensate, a linkage connected to the bucket closes or opens a discharge valve trapping the condensate or allowing it to escape.

The inverted bucket trap is a simple design in that it has a unique leverage system that multiplies the force provided by the bucket to open the valve against pressure. Since the bucket is open at the bottom, it resists damage from water hammer and wear points are heavily reinforced for long life. The inverted bucket has only two moving parts - the valve lever assembly and the bucket. That means no fixed points, no complicated linkage, nothing to stick, bind or clog.



IB18H

Drain & Tracer, Process & Space Heating

The IB18H Series are horizontal bucket traps featuring a side inlet and side outlet. They are ideal for general purpose steam service and feature a heavy duty cast iron body and stainless steel bucket for long-term operation and reliability.

Sizes	1/2", 3/4", 1", 1-1/4", 1-1/2", 2", 2-1/2"
Body Material	Cast Iron
Max Allowable Pressure	250 psi (17,2 bar) (depending on body an orifice size)

IB18S

Drain & Tracer, Process & Space Heating

The IB18S Series are horizontal inverted bucket traps ideal for general condensate removal service and feature a built-in strainer, heavy-duty cast iron body and stainless steel bucket for long-term operation and reliability.

Sizes	1/2", 3/4", 1", 1-1/4"
Body Material	Cast Iron
Max Allowable Pressure	250 psi (17,2 bar) (depending on body an orifice size)



IB18V

Drain & Tracer, Process & Space Heating, High Pressure

The IB18V Series vertical style inverted bucket traps are ideal for general condensate removal service and feature a heavy-duty cast iron body and stainless steel bucket for long-term operation and reliability.

Sizes	1/2", 3/4", 1", 1-1/4", 1-1/2", 2"
Body Material	Cast Iron
Max Allowable Pressure	250 psi (17,2 bar) (depending on body an orifice size)

IB21V/41V

Drain & Tracer, Process & Space Heating, High Pressure

The IB21V & IB41V Series inverted bucket traps are ideal for higher pressure services and feature a heavy-duty carbon steel body and stainless steel bucket for long-term operation and reliability.

Sizes	IB21V: 1/2", 3/4"; IV41V: 1/2", 3/4", 1", 1-1/2", 2"
Body Material	Carbon Steel
Max Allowable Pressure	IB21V: 300 psi (20,7 bar); IB41V: 600 psi (41,4 bar)





FLOAT & THERMOSTATIC TRAPS

When steam pressure may vary from maximum steam supply pressure to vacuum, Float & Thermostatic Traps are your most energy-efficient choice. If you need performance, dependability and long life to trapping services requiring continuous drainage with high air venting capacity, the FTH and PT Series can help.

How they work: When steam is turned on, the float is resting in its lowest position with the valve closed. Condensate entering the trap does not begin to lift the float until the valve seat is covered. After this level is reached, any further addition of condensate will raise the float, the higher the level the greater the valve opening. Our traps are designed to modulate the flow of condensate with the rise and fall of the float as changes in condensate level occur within the trap cover. All working parts of the trap are attached to the body casting for easy repair access.

FTH-10

Process & Space Heating

The FTH-10 Series float and thermostatic steam traps are designed to freely remove large quantities of condensate from systems where dirt and oil are not excessive. They can be found on receivers, separators, intercoolers, reservoirs and drip legs.

Sizes	1/2", 3/4", 1", 1-1/2", 2"
Body Material	Cast Iron
Max Allowable Pressure	250 psi (17 bar)



PT

Process & Space Heating

The PT Series is a group of float & thermostatic traps for use in the discharging of air and condensate, while preventing steam from entering return piping on steam heating systems and steam process equipment. These traps can be piped in and out from either side, providing installation flexibility. Four models are available to meet a variety of pressure requirements.

Sizes	3/4", 1", 1-1/4", 1-1/2", 2"
Body Material	Cast Iron
Max Allowable Pressure	250 psi (17,2 bar)



TOTAL TRAPS

The Total Trap Series is a line of compact, thermodynamic style steam trap stations for saturated steam designed to efficiently discharge condensate on applications with working pressures up to 2000 psig (138 bar) and temperatures up to 1000°F (538°C).

The Total Trap Series is a one piece, self-contained total steam trap station. The disc trap comes with a replaceable cartridge, disc and cap which can easily be replaced in the field without uninstalling the complete trap station. Installation is easy requiring only 2 welds and less than 14" (0,55mm) of space end-to-end. Optional size inlet and outlet hub ends are available in a variety of material and sizes to meet customer piping applications.



2&3

Total Traps

A line of compact, thermodynamic style steam trap stations for saturated steam designed to efficiently discharge condensate on applications with working pressures up to 600 psi (41 bar).

Body Material	Stainless Steel
Max Operating Pressure	600 psi (41 bar)
Max Differential Pressure	4 psi (0,28 bar)
Max Operating Temp	450°F (232°C)

3HP

High Pressure Total Traps

A line of compact, thermodynamic style steam trap stations for saturated steam applications designed to efficiently discharge condensate on applications with working pressures up to 900 psi (62 bar) and temperatures up to 800°F (427°C).

Body Material	Stainless Steel
Max Operating Pressure	900 psi (62 bar)
Max Differential Pressure	10 psi (0,69 bar)
Max Operating Temp	800°F (427°C)



4

High Pressure Total Traps

The Total Trap 4 is a compact, thermodynamic style steam trap station for superheated steam applications designed to efficiently discharge condensate on applications with working pressures up to 2000 psi (138 bar) and temperatures up to 1000°F (538°C).



Body Material	Stainless Steel
Max Operating Pressure	2000 psi (138 bar)
Max Differential Pressure	1800 psi (124 bar)
Max Operating Temp	1000°F (538°C)



ACCESSORIES

Bestobell offers specialized accessories to maximize the efficiency of your systems including pressure regulators, steam detectors and y-type strainers.

Our pressure regulators help manage steam systems safely and efficiently to ensure uninterrupted productivity by maintaining constant pressure for process control.

Our steam trap testing device allows any steam trap technician to survey traps quickly, easily and accurately to ensure no live steam loss.

Our Y-type line strainers protect your steam system against the damage to valves, traps and other equipment from foreign matter such as dirt, scale or welding particles in the pipeline.



PR3G

Pressure Regulating Valves

A hard-seated pressure reducing and regulating valve suitable for steam applications with supply pressures up to 300 psi (20,7 bar). The PR3G offers exceptional performance, easy in-line maintenance, and heavy duty construction for reliable, long-term operation.

Sizes	1/2", 3/4", 1", 1-1/2", 2"
Body Material	Ductile Iron, Carbon Steel, Stainless Steel
Max Inlet/Outlet Pressure	300 psi (20,7 bar) / 200 psi (13,8 bar)

STEAM TECTOR

Leak Detection

High sensitivity and great sound quality in a compact package designed for one hand operation. Included in a hard shell case is the instrument, flexible wave guide, headset, touch probe and battery.

Construction	Durable ABS and anodized aluminum
Display	10 element bargraph
Headset	Dynamic 32 ohm



Y STRAINER

Line Strainers



Y-type line strainers protect your steam system against the damage to valves, traps and other equipment from foreign matter such as dirt, scale or welding particles in the pipeline. Available in threaded or flanged end connections.

Sizes	1/2", 3/4", 1", 1-1/4", 1-1/2", 2", 2-1/2"
Body Material	Cast Iron, Bronze, Carbon Steel, Stainless Steel
Pressure Ratings	ANSI 125#: CI, BR; ANSI 150#: BR, CS, SS; ANSI 250#: CI, BR; ANSI 300#: CS, SS; ANSI 600#: CS, SS



BESTOBELLSTEAM

3170 Wasson Rd. Cincinnati, OH 45209 • 513.533.5600 • steam@richardsind.com • www.bestobellsteamtraps.com