



FEATURES

- *Balanced plugs for use with smaller more economical actuators.*
- *Flash-Flo® cages offer an economical solution for low pressure choked liquid and gas applications.*
- *Q-Cage™ and Q-Cage™ Level 2 provide additional noise reduction and eliminates cavitation for more demanding applications.*
- *VeCTor™ trim eliminates the damaging effects of noise and erosion typically associated with severe service applications.*
- *Optional live-loaded PTFE and graphite packing.*
- *Standard metal seats offer Class IV shut-off when used with the standard PTFE piston seals or Class V with optional spring loaded PTFE cup seal.*
- *Soft seat inserts simplify maintenance and offer Class VI shut-off when combined with the optional spring loaded PTFE cup seal.*
- *Standard balanced plug accepts metal and carbon graphite seals for services that exceed the PTFE seals' application limits.*
- *Unbalanced plugs offer tight shut-off for higher temperature applications.*

Series G110 Globe And Angle Valves 1 1/2"-16" (DN40 - 400) ANSI Class 150-600

The G110 Series is a cage trim control valve product line designed with a fully integrated, interchangeable system of parts. This line has all the product variations of comparable lines, without the use of multiple seats, redundant seals or seat ring adapters. All standard cages for a given valve size have constant bore diameters. Cv reductions are achieved by reducing the area of cage openings, not by changing seat diameters or valve travel, thus eliminating the need for changing additional trim parts. The end result is a streamlined product offering that provides maximum versatility and flexibility, yet requires a minimum of inventory and maintenance time. The G110 cage-guided trim style is ideal for clean liquids, gases and steam in moderate to high temperatures and pressures.

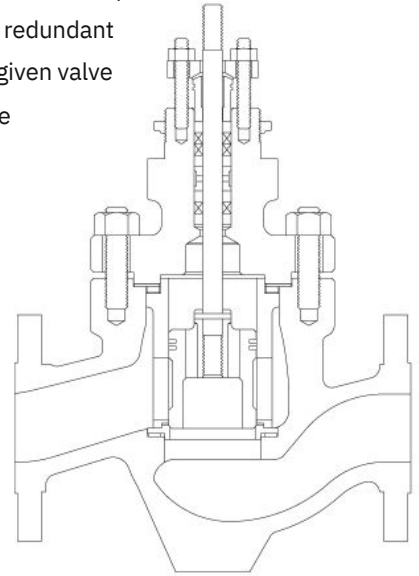

Specifications

Body Style: Globe or angle.

Body Sizes: Globe - 1-1/2" through 16" (40-400 mm).

Angle - 1-1/2" through 8" (40-200 mm).

Body Rating: ANSI Class 150, 300, 600.

Body Materials: Carbon steel, Chrome-Moly steel, Stainless steel. Other castable alloys including Monel®, Hastelloy® C, and Alloy 20 available on application.

End Connections: NPT threaded or socket weld (1-1/2" and 2"): ANSI flanged (1-1/2" through 16"): ANSI butt weld (1-1/2" through 16"). Others available upon request.

Bonnets: Plain, extension, bellows seal, ultra-low temperature extension.

Trim Style: Balanced and unbalanced plugs, cage-retained seat rings (1-1/2" - 16").

Trim Characteristic: Linear and equal percentage characteristics in standard ported and drilled Flash Flo® cages, two levels of linear Q-Cage trims. Others available upon request.

Flow Coefficient: Cv from 12 through 2600 (refer to Tables on page 6).

Leakage Class: II, III, IV, V, and VI.

Actuators: Standard bonnet mount will accept spring-diaphragm, piston and other actuators. For actuator selection, refer to KOSO Hammel Dahl actuator selection guide.

G110 Seat Ring and Cage Options

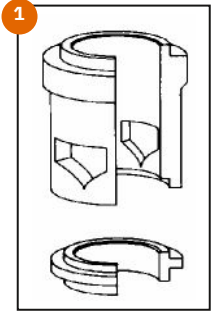

Figure 1. Metal Seat Ring and Ported Cage

Standard construction is a dual function cage and separate seat ring. The cage acts as a massive plug guide and seat retainer, in addition to establishing the flow characteristic. The cage shown has openings that will provide an equal percentage characteristic. A linear characteristic is also available.

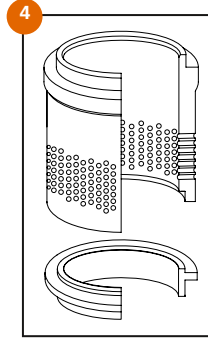

Figure 4. Q-Cage™

The Q-Cage™ trim is a drill hole cage design that utilizes both the energy shift and mutual interference methods in compressible services for optimal noise reduction. This design can reduce noise generated by up to 20 dBA. In liquid (usually water) applications, it further limits the energy in each flow passage and also slightly reduces the valve pressure recovery, thereby further reducing the effects of cavitation damage. The Q-Cage™ is available with special modified flow characteristics.

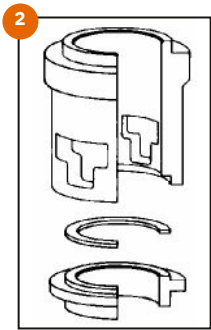

Figure 2. Soft-Seat Ring and Ported Cage

The standard soft-seated design is the same cage and seat ring with a PTFE insert. This soft-seated design combined with the balanced plug will provide ANSI Class VI leakage. The cage shown has openings that will provide a linear characteristic. Equal percentage is also available. Available in 1-1/2" – 8".

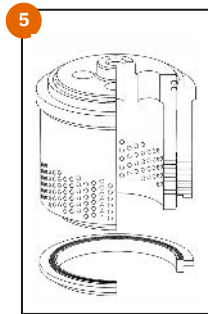

Figure 5. Q-Cage™ Level 2

The Q-Cage™ Level 2 trim incorporates the Q-Cage™ trim with a plug skirt that allows up to another 10 dBA noise reduction by adding another pressure reducing stage to the trim. In this way, the Q-Cage™ Level 2 trim can handle higher energy levels, while providing lower noise generation and eliminating cavitation. Unlike other multi stage drilled hole trim, this design is the only one where both stages are active, that is, the flow area of both stages varies with plug stroke. The Q-Cage™ Level 2 is available with special modified flow characteristics.

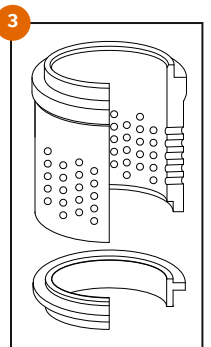

Figure 3. Flash Flo®

This design utilizes a series of diametrically opposed holes that break the flow stream into many smaller streams. For liquid applications, flow direction is "flow over" or into the cage. The high velocity streams impinge upon each other, dissipating the energy and minimizing the effects of cavitation. For gas and steam applications, flow direction is "flow under" or out of the cage. The high velocity streams radiate out of the cage allowing the media to expand and causing a redistribution of the acoustical energy. Unlike competitive designs, Flash Flo is available in equal percentage as well as linear characteristics.

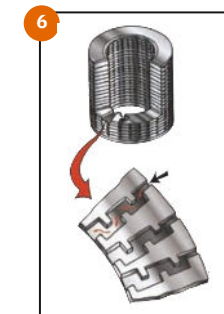

Figure 6. VeCTor™ trim

VeCTor™ trim is a radial flow multi-stage stacked disk trim designed with constant area ratios that provide a torturous path controlled pressure drop at each stage. Use of this design totally precludes the high velocity in compressible flow that creates noise or the critical pressure drops in liquid flow that creates cavitation. This product is offered as a linear, modified linear and modified equal percent flow characteristics. The disk stack is available in 316 SS, 410 SS and INCONEL®.

G110 Plug and Seal Ring Options

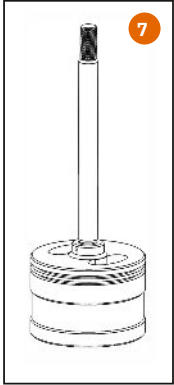

Figure 7. Standard Balanced Plug

The standard balanced plug is a piston style that has a primary metal seat and secondary bi-directional piston rings set in ring grooves. The pressure above the plug is equalized with the pressure below the seat ring by large vent holes that pass completely through the plug. In the closed position, the plug seats on the seat ring and the piston rings seal the annulus between the upper plug and cage. Standard plug seals are PTFE energized by Viton O-ring (refer to Figure 16 for pressure temperature capability). Metal seals or carbon graphite rings are used beyond the capability of the PTFE ring.

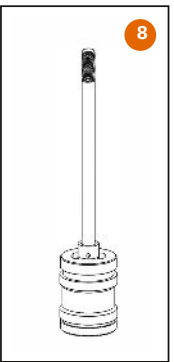

Figure 8. Optional Balanced Plug

This unique design includes a special unidirectional, spring-loaded, pressure-energized PTFE cup seal. Upstream pressure enters the seal cavity expanding the seal outward, sealing the annulus between the plug and cage walls. This seal, in conjunction with the TFE soft seat ring, ensures ANSI Class VI leakage (refer to Figure 20).

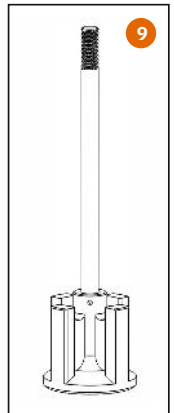

Figure 9. Unbalanced Plug

An unbalance plug is available for those smaller sized applications where tight shutoff is required but service conditions exceed the required seal capabilities. The standard flow direction for unbalanced plugs is flow to open (i.e., from under the plug).

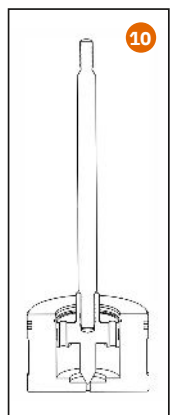

Figure 10. Pilot Plug

For those applications where a tight shut-off is required and the service conditions exceed the required seal capabilities, a pilot plug is available. The standard flow direction is flow to close (i.e., from over the plug).

G110 Bonnet Options

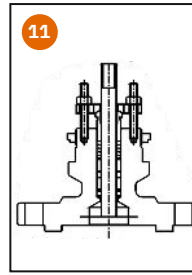

Figure 11. Plain Bonnet

A plain bonnet is used when the flow media remains between -50°F to 600°F (-46°C to +316°C); available with standard or live-loaded packing configurations.

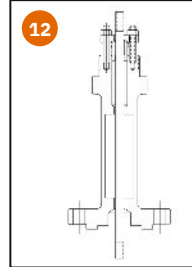

Figure 12. Extension Bonnets

An extension bonnet is required for high temperature applications from +600°F to +1000°F (+316°C to +538°C).

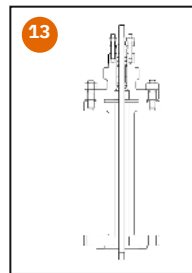

Figure 13. Ultra-low Temperature Extension Bonnets

Ultra-low temperature extension bonnet is available for applications between -320 °F to -50 °F (-195 °C to -46 °C) for valve sizes 1-1/2 to 6 inches. Use an extension bonnet for valve 8 to 16 inches.

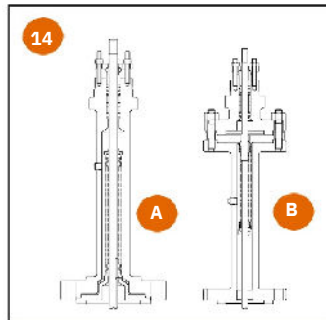
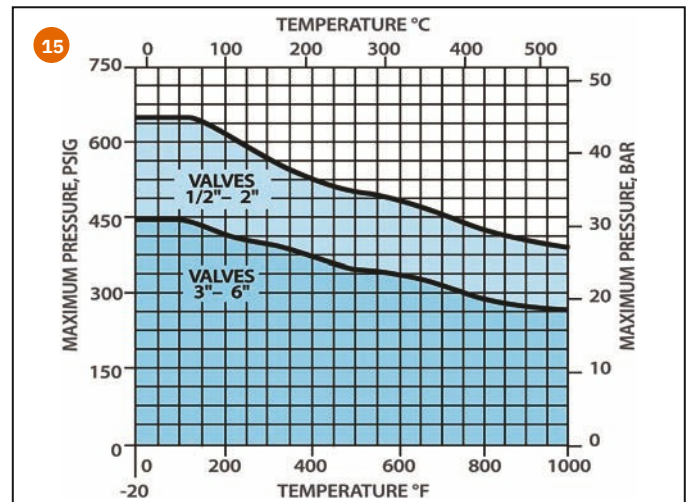

Figure 14. Bellows Seal Bonnets

A bellows seal bonnet is used when stem leakage can not be tolerated because media is toxic, flammable, explosive or precious. Refer to the chart below for bellows temperature and pressure limits. Sizes 1/2 to 2 inches, the bellows seals are externally pressurized (see A). Sizes 3 inches and above, the bellows seals are internally pressurized (see B).

Figure 15. Bellows Seal Rating Chart



Shutoff Performance

Table 1. Valve Leakage Classes

Plug Style	Seat Ring	Plug Seal	ANSI Class
Unbalanced	Metal	Not Applicable	IV or V
	PTFE		VI
Balanced	Metal	PTFE / O-ring	IV
		PTFE Cup Seal	IV or V
		Carbon Graphite	II
		Metal	III
	PTFE	PTFE / O-ring	IV
		PTFE Cup Seal	VI

Above leakage classes as defined in ANSI B16, 104. Viton is a registered trademark of E.I. DuPont Co.

Table 2. Noise

Aerodynamic Noise Attenuation	Flash Flo®	Up to 10 dbA
	Q-Cage™	Up to 20 dbA
	Q-Cage™ Level 2	Up to 30 dbA

Table 3. Flow Direction

NOTE: Flow direction must be specified at time of order entry.

Media	Plug	Cage	Flow Direction
Clean Liquids	Balanced	Ported	Flow Over
		Flash Flo®	
		Q-Cage™	
		Q-Cage™ Level 2	
Gas or Steam	Balanced	Ported	Flow Under
		Flash Flo®	
		Q-Cage™	
		Q-Cage™ Level 2	
Clean Liquids	Unbalanced	Ported	Flow Under
		Flash Flo®	
		Q-Cage™	
		Q-Cage™ Level 2	

The unbalanced plug used in conjunction with any metal seat ring will provide Class IV shutoff or Class V shutoff. When used with the PTFE soft seat, this plug will provide Class VI shutoff. (Refer to Figure 20).

The standard plug seal for temperatures below 400°F (204°C) is a PTFE piston seal energized by a Viton® “O” ring (refer to Figure 16 for pressure and temperature limitations). Supplied with any metal seat ring, this seal will provide Class IV shutoff.

A plug seal for temperatures and pressures beyond the capability of the PTFE piston ring is carbon graphite. This seal supplied with any metal seated cage will provide Class II shutoff. 400 °F to 1 000 °F (204 °C to 537 °C).

The standard plug seal for temperatures and pressures beyond the capability of the standard PTFE piston ring is a metal piston ring, which provides Class III shutoff. 400 °F to 800 °F (204 °C to 426 °C). This metal piston ring is for non-steam, non-caustic applications only. For steam or caustic applications, consult factory.

For those applications where Class V shutoff is required in a balanced valve, a special spring-loaded pressure-energized PTFE cup seal is available to be used in conjunction with 30° seat angle. (Refer to Figure 16 for pressure and temperature limitations.) This seal, used in conjunction with a PTFE soft seat, provides Class VI shutoff. (Refer to Figure 20 for pressure and temperature limitations.)

Figure 16. TFE Plug Seal Rating Chart

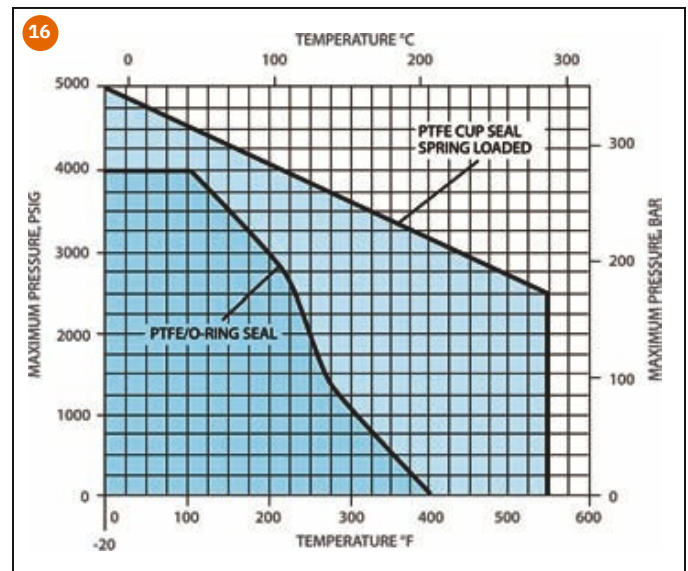

Material Selection

These charts should be used to select the pressure class and trim material combination. The curves sloping downward to the right are the pressure rating curves for each ANSI pressure class as listed in ANSI B16.34. In each case, the curve designates the maximum pressure and temperature for the class listed directly below the curve. The bold boundaries mark the recommended pressure and temperature limits for trim material combinations listed in the tables below. All recommendations are generalized and may be subject to adjustment based upon hydraulic considerations determined during the valve sizing process.

Figure 17. Trim Chart for Stainless Steel Body
(ASTM A351, CF8M)

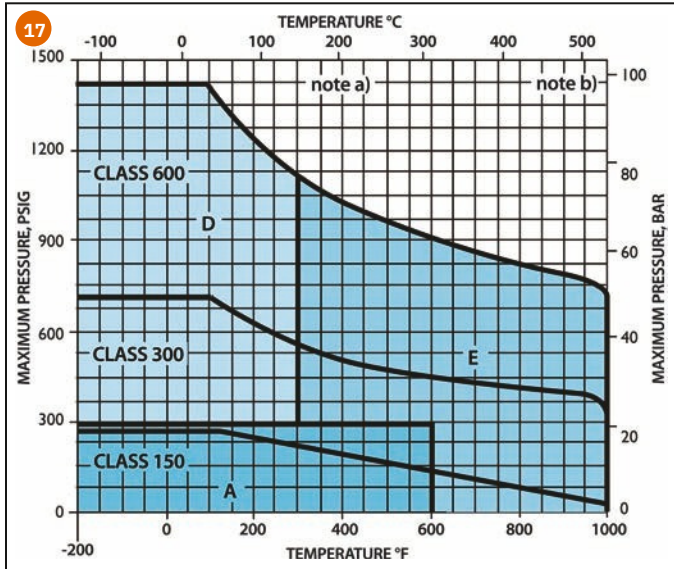

Table 4. G110 Trim Chart

Trim Code	Plug	Seat Ring	Cage	Stem
8	416 SS	416 SS	17-4 PH/CP	316 SS
A	316 SS	316 SS	316 SS/CP	316 SS
B	416 SS	416 SS/TFE	17-4 PH/CP	316 SS
C	316 SS	316 SS/TFE	316 SS/CP	316 SS
D	316 SS/HFS	316 SS/HFS	316 SS/CP	316 SS
E	316 SS/HFS+G	316 SS/HFS	316 SS/CP	316 SS
N	416 SS/N	416 SS	416 SS/N	316 SS
W	316 SS/HFS+G	316 SS/HFS	316 SS/N	316 SS

NOTES TO TABLE AND TRIM CHARTS

- a) Above +600 °F (316 °C) extension bonnet is required.
- b) For service temperature above +1 000 °F (+538 °C) contact the factory.
- c) Unless otherwise specified, the hard-facing is Alloy 6.
- d) CP=Chrome plated.
- e) N=Nitrided.
- f) For PTFE soft-seated trim selections see Figure 20. Other materials available upon request.
- g) KOSO Hammel Dahl reserves the right to substitute materials when appropriate base upon service or availability.

Table 5. Packing Materials

-200 °F to +450 °F (-129 °C to +232 °C)	+450 °F to +900 °F (+232 °C to +482 °C)
TFE V-ring/Spacer	Laminated Graphite
TFE Impregnated PTFE Braid	Live-loaded Graphite
Double TFE V-ring/Spacer	
Lubricated Aramid Braid	
Live-loaded TFE V-ring	

Figure 18. Trim Chart for Carbon Steel Body
(ASTM A216, WCB)

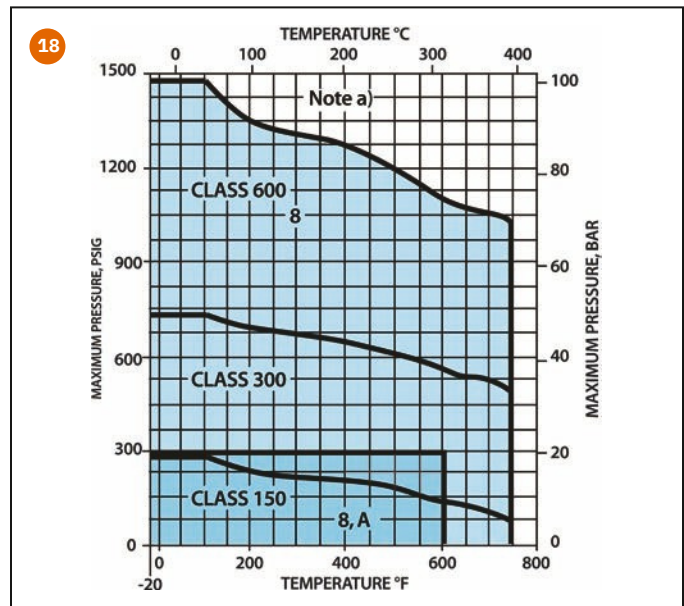

Figure 19. Trim Chart for Chrome Moly Body
(ASTM A217, WC9)

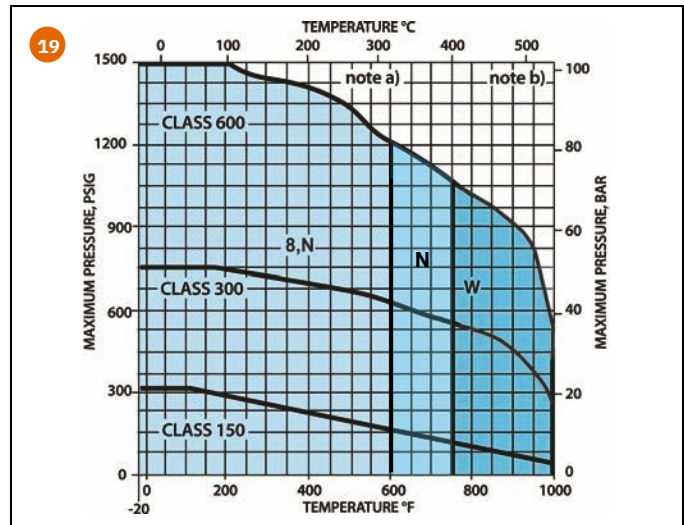
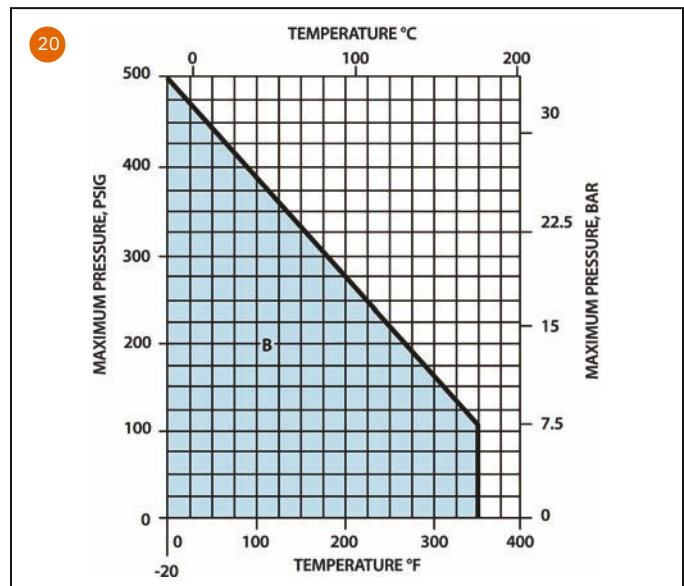

Figure 20. PTFE Soft Seat Rating Chart



Weights and Dimensions

Table 6. G110 & G112

Globe Body Dimensional Data—inches (mm) ANSI Classes 150-600

Body Size Inches (mm)	Travel	A					C	D				Approx. Weight lb (kg)*
		Screwed or Socket Weld	Flanged			Butt Weld		Plain Bonnet	Extension Bonnet	U.L.T. Extn. Bonnet	Bellows Bonnet	
			Class 150-600	Class 150	Class 300							
1-1/2 (40)	1.12 (28)	9.88 (251)	8.75 (222)	9.25 (235)	9.88 (251)	9.88 (251)	3.19 (81)	5.88 (149)	11.10 (282)	15.50 (394)	16.10 (409)	65 (29)
2 (50)	1.12 (28)	11.25 (286)	10.00 (254)	10.50 (267)	11.25 (286)	11.25 (286)	3.62 (92)	5.92 (150)	11.45 (291)	17.52 (445)	18.12 (460)	70 (32)
3 (80)	1.50 (38)	—	11.75 (298)	12.50 (318)	13.25 (337)	13.25 (337)	4.38 (111)	7.27 (185)	11.81 (300)	19.27 (489)	19.27 (489)	145 (66)
4 (100)	1.50 (38)	—	13.88 (353)	14.50 (368)	15.50 (394)	15.50 (394)	5.31 (135)	8.08 (205)	11.96 (304)	23.89 (607)	23.89 (607)	230 (104)
6 (150)	2.25 (57)	—	17.75 (451)	18.62 (473)	20.00 (508)	20.00 (508)	6.75 (171)	9.87 (251)	14.68 (373)	26.06 (662)	26.06 (662)	470 (213)
8 (200)	3.50 (89)	—	21.38 (543)	22.38 (568)	24.00 (610)	24.00 (610)	8.44 (214)	13.25 (337)	18.00 (457)	—	—	1210 (549)
10 (250)	3.50 (89)	—	26.50 (673)	27.88 (708)	29.62 (752)	29.62 (752)	10.38 (264)	15.75 (400)	25.25 (641)	—	—	1750 (794)
12 (300)	3.50 (89)	—	29.00 (737)	30.50 (775)	32.25 (819)	32.25 (819)	12.13 (308)	16.50 (419)	28.88 (734)	—	—	2488 (1129)
16 (400)	10.0 (254)	—	40.00 (1016)	41.62 (1057)	43.62 (1108)	43.62 (1108)	16.13 (410)	32.06 (814)	—	—	—	3570 (1619)

*Weights are for ANSI Class 600 flanged valves with plain bonnet.

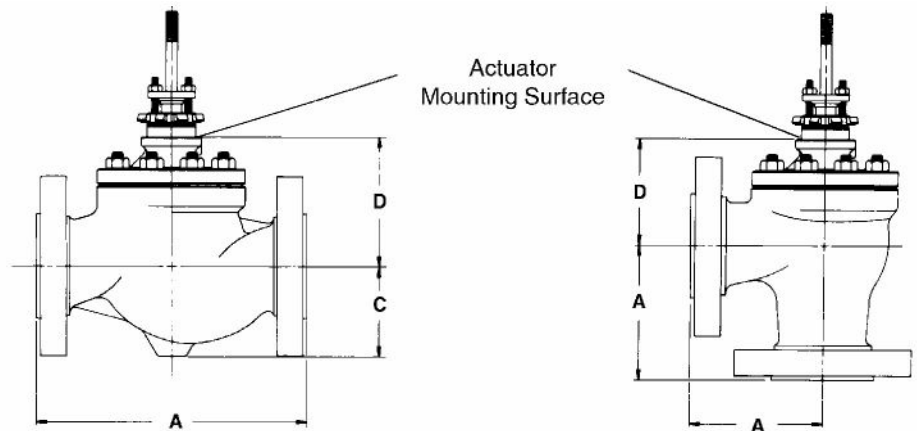

Table 7. G111 & G113

Angle Body Dimensional Data—inches (mm) ANSI Classes 150-600

Body Size Inches (mm)	Travel	A					D	D				Approx. Weight lb (kg)*
		Screwed or Socket Weld	Flanged			Butt Weld		Plain Bonnet	Extension Bonnet	U.L.T. Extn. Bonnet	Bellows Bonnet	
			Class 150-600	Class 150	Class 300							
1-1/2 (40)	1.12 (28)	4.94 (125)	4.38 (111)	4.62 (117)	4.94 (125)	4.94 (125)	5.19 (132)	10.41 (264)	14.81 (376)	15.41 (391)	65 (29)	
2 (50)	1.12 (28)	5.62 (143)	5.00 (127)	5.25 (133)	5.62 (143)	5.62 (143)	5.00 (127)	10.52 (267)	16.59 (421)	17.19 (437)	70 (32)	
3 (80)	1.50 (38)	—	5.88 (149)	6.25 (159)	6.62 (168)	6.62 (168)	5.71 (145)	10.52 (267)	17.71 (450)	17.71 (450)	145 (66)	
4 (100)	1.50 (38)	—	6.94 (176)	7.25 (184)	7.75 (197)	7.75 (197)	6.90 (175)	10.78 (274)	22.71 (577)	22.71 (577)	230 (104)	
6 (150)	2.25 (57)	—	8.88 (226)	9.31 (236)	10.00 (254)	10.00 (254)	7.50 (191)	12.31 (313)	23.69 (602)	23.69 (602)	470 (213)	
8 (200)	3.50 (89)	—	10.69 (272)	11.19 (284)	12.00 (305)	—	—	9.25 (235)	14.07 (357)	—	1210 (549)	

*Weights are for ANSI Class 600 flanged valves with plain bonnet.

Flow Data

Table 8. G110 & G111 Balanced Style Trim
Flow Coefficient (Cv) at Maximum Travel

Cage Style	Flow Characteristics	Size	Size Code	Valve Sizes—inches (mm)								
				1-1/2 (40)	2 (50)	3 (80)	4 (100)	6 (150)	8 (200)	10 (250)	12 (300)	16 (400)
Standard Ported	Equal Percentage	Full Size	A	37	60	120	170	362	650	950	1275	2500
		1 Reduction	B	24	38	77	109	258	415	540	725	1375
		2 Reduction	C	14	23	41	64	151	230	400	545	1025
	Linear	Full Size	A	40	65	132	212	461	735	1050	1400	2600
		1 Reduction	B	34	49	97	156	355	455	610	820	1450
		2 Reduction	C	27	38	71	100	195	280	420	565	1100
Flash Flo®	Equal Percentage	Full Size	A	33	53	120	142	298	610	950	1275	2500
		1 Reduction	B	21	32	73	86	193	420	—	—	—
		2 Reduction	C	13	21	58	66	120	240	—	—	—
	Linear	Full Size	A	35	55	105	168	387	720	1050	1400	2600
		1 Reduction	B	27	36	62	107	220	420	610	820	1450
		2 Reduction	C	16	26	44	77	147	285	420	565	1100
Q-Cage™	Equal Percentage	Full Size	A	29	40	69	123	188	431	495	657	1899
		1 Reduction	B	20	30	52	100	158	373	415	566	1617
		2 Reduction	C	10	21	35	76	127	313	334	474	1317
	Linear	Full Size	A	41	56	105	173	304	647	765	1002	2865
		1 Reduction	B	29	44	82	142	257	566	646	869	2510
		2 Reduction	C	15	30	56	109	209	480	523	731	2101
Q-Cage™ Level 2	Equal Percentage	Full Size	A	16	17	42	61	101	251	266	304	1056
		1 Reduction	B	8	8	28	41	76	201	200	228	800
		2 Reduction	C	—	—	1	2	6	25	24	31	144
	Linear	Full Size	A	25	26	69	92	175	404	438	493	1795
		1 Reduction	B	13	13	47	62	132	327	331	371	1384
		2 Reduction	C	—	—	24	31	89	247	222	248	942
VeCTor	Equal Percentage / Linear	Consult Factory	Consult Factory									

Table 9. G112 & G113 Unbalanced Style Trim
Flow Coefficient (Cv) at Maximum Travel

Cage Style	Flow Characteristics	Size	Size Code	Valve Sizes—inches (mm)								
				1-1/2 (40)	2 (50)	3 (80)	4 (100)	6 (150)	8 (200)	10 (250)	12 (300)	16 (400)
Standard Ported	Equal Percentage	Full Size	A	39	61	130	186	401	740	1000	1325	2500
		1 Reduction	B	25	38	81	111	246	455	560	740	1375
		2 Reduction	C	14	23	42	59	138	277	410	530	1025
	Linear	Full Size	A	42	63	140	220	485	770	1100	1450	2600
		1 Reduction	B	35	50	99	157	348	475	630	850	1450
		2 Reduction	C	27	37	70	97	185	277	445	580	1100
VeCTor	Equal Percentage / Linear	Consult Factory	Consult Factory									

How To Order

To completely specify a control valve, make a selection from each category in the Valve Model Coding System below. The assembled codes create a complete valve model number. The Valve Model Coding System displays the standard product offering for this product line. An extensive number of options and variations exist, which are not listed. For options not shown or to enter an order, contact your local sales representative.

Note: A "Z" on any code position refers to a special configuration

1	Series Models
G110	Balanced, Globe
G111	Balanced, Angle
G112	Unbalanced, Globe
G113	Unbalanced, Angle

2	Body Size
H	1-1/2" (40 mm)
J	2" (50 mm)
L	3" (80 mm)
N	4" (100 mm)
Q	6" (150 mm)
S	8" (200 mm)
T	10" (250 mm)
U	12" (300 mm)
W	16" (400 mm)

3	Body Rating
G	ANSI Class 150
H	ANSI Class 300
F	ANSI Class 600

4	Body Material
C	Carbon Steel (ASTM A216, WCB)
E	Stainless Steel (ASTM A351, CF8M)
2	Chrome-Moly Steel (ASTM A217, WC9)

5	End Connections
3	Raised Face Flange
4	NPT Threaded
6	Socket Weld
8	Butt Weld Sch. 40
9	Butt Weld Sch. 80

6	Bonnet Type
2	Plain
3	Ultra-low Temperature Extension
4	Extension
5	Bellows

7	Trim Characteristics
C	Linear
E	Equal Percent
F	Flash Flo®, Equal Percent
H	Flash Flo®, Linear
Q	Q-Cage™, Linear
R	Q-Cage™ Level 2, Linear (FTO)
S	Q-Cage™ Level2, Linear (FTC)
V	VeCTor™, Linear

8	Trim Size
A	Full Size
B	1 Reduction
C	2 Reduction

9 Trim Materials				
Trim Code	Plug	Seat Ring	Cage	Stem
8	416 SS	416 SS	17-4 PH/CP	316 SS
A	316 SS	316 SS	316 SS/CP	316 SS
B	416 SS	416 SS/TFE	17-4 PH/CP	316 SS
C	316 SS	316 SS/TFE	316 SS/CP	316 SS
D	316 SS/HFS	316 SS/HFS	316 SS/CP	316 SS
E	316 SS/HFS+G	316 SS/HFS	316 SS/CP	316 SS
N	416 SS/N	416 SS	416 SS/N	316 SS
W	316 SS/HFS+G	316 SS/HFS	316 SS/N+CP	316 SS

10 Packing/Plug Seal Materials		
G110 & G111		
	Packing ⁽¹⁾	Plug Seal ⁽²⁾⁽³⁾
A	PTFE V-Ring/Spacer	PTFE/O-Ring
F	PTFE V-Ring/Spacer	PTFE Cup Seal
B	Double PTFE V-Ring/Spacer	PTFE/O-Ring
K	Double PTFE V-Ring/Spacer	PTFE Cup Seal
P	Laminated Graphite	PTFE/O-Ring
Q	Laminated Graphite	PTFE Cup Seal
S	Laminated Graphite	Carbon Graphite
Y	Laminated Graphite	Metal
N	Live-loaded PTFE V-Ring	PTFE/O-Ring
R	Live-loaded PTFE V-Ring	PTFE Cup Seal
G112 & G113 Series		
-200 °F to +450 °F (-129 °C to +232 °C)		
G	TFE V-Ring/Spacer	
U	TFE Impregnated PTFE Braid	
Y	Double TFE V-Ring/Spacer	
W	Lubricated Aramid Braid	
B	Live-loaded TFE V-Ring	
+450 °F to +900 °F (+232 °C to +482 °C)		
9	Laminated Graphite	

- (1) Other packing materials available upon request.
- (2) Refer to TFE Plug Seal Rating Chart (page 4) for pressure/temperature rating.
- (3) Refer to Valve Leakage Classes (page 4) for temperature rating.

11	Variations
—	None
A	Body Drain
B	Bonnet Lube Connection Only
D	Bonnet Lube Connection w/ISO Valve
J	125 RMS Flange Face Finish
K	17-4 PH Stem
N	NACE MR-01-75 / ISO 15156
T	28/30 Degree Seat Angle

Refer to page 5 for additional trim reduction options.

D/R Series Linear Spring Diaphragm Pneumatic Actuators

KOSO Hammel Dahl linear spring diaphragm pneumatic actuators are rugged units designed for reliable operation of linear control valves. The available combinations of case sizes, strokes, and springs precisely satisfy a wide range of application requirements.

FEATURES

- *Rolling diaphragm provides excellent sensitivity and provides maximum constant effective area which translates into improved linearity.*
- *Modular construction provides maximum part interchangeability between direct and reverse-acting models and between selected case sizes.*
- *High spring rates improve control valve stability.*
- *Minimal guiding assures low hysteresis in reverse-acting models—zero hysteresis in direct-acting models.*
- *Stainless steel stems are standard for maximum performance in corrosive environments.*

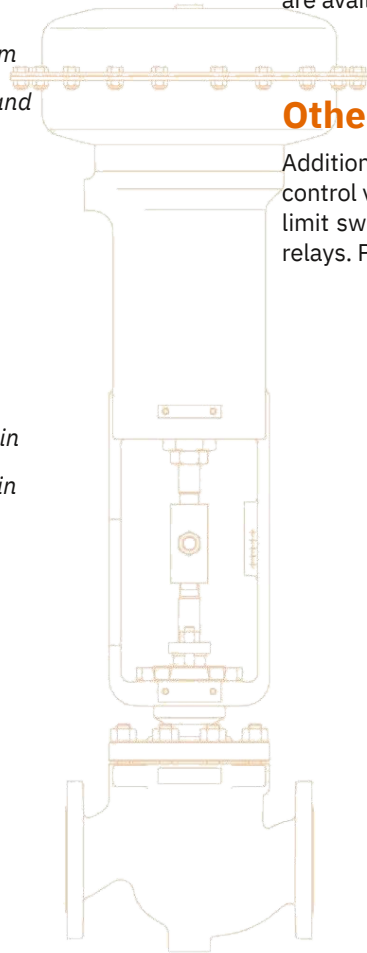

Specifications

Diaphragm Cases: Pressed steel.

Stem: 303 SS.

Diaphragm: Dacron reinforced nitrile.

Spring Barrel: Cast Iron.

Temperature Limits: -40°F to +180°F (-40°C to +82°C).

Standard Spring Spans: 12 psi and 24 psi (.8 bar and 1.7 bar), (other spans and spring preloads available on application).

Positioners

Pneumatic, electro-pneumatic and digital positioners improve repeatability and accuracy while providing increased force to reduce actuator sizes. Pneumatic positioners accept a 3-15 psi input, while electro-pneumatic positioners typically accept a 4-20 mA signal. Most digital positioners provide extensive monitoring or diagnostics, as well as improved response speed. Several industry-recognized brands are offered. Others are available upon request.

Other Accessories

Additional accessories available for mounting with linear control valves include, but are not limited to transducers, limit switches, lock-up valves, solenoid valves and amplifying relays. Please consult the factory for complete details.

07/23

KOSO HAMMEL DAHL
253 Pleasant Street
W.Bridgewater, MA 02379

Telephone: 774.517.5300
www.hammeldahl.com

KOSO VECTOR kentintrol™

REX
ELECTRAULIC™ ACTUATION

PARCOL

CONTROL VALVES
KOSO HAMMEL DAHL