

## CHV HIGH VOLUME BOOSTER



Utilizing the same microcontroller, integrated pressure sensors, and two Clippard EVP proportional valves, Clippard's Cordis booster series provides precise linear pressure control similar to that of the CPC series with the added benefit of phenomenal forward and reverse flow characteristics. With the inlet and exhaust valves connected to the pilot area of the integral volume booster, the comparative circuit responds to the given command by referencing the on-board sensor located on the output control path of the booster. If at any point the on-board downstream sensor indicates a value higher or lower than the set point command, the comparative circuit immediately opens either the exhaust or inlet valve to maintain stable and accurate control pressure in the application process, but with significantly high flow capabilities.

- Smooth linear control
- Integrated downstream sensor feedback
- Analog and 3.3V serial command
- Significant forward and reverse flow characteristics
- Static or dynamic applications
- High resolution
- Proportional fill and bleed control
- Customizable pressure ranges and mounting options
- No integral bleed required to maintain high resolution
- Ideal for use with expensive inert gases

<b>Accuracy</b>	±0.50% of full scale
<b>Current Draw</b>	<250 mA max.
<b>Filtration</b>	40 micron filter ( <i>recommended</i> )
<b>Flow Characteristics</b>	42.5 scfm @ 80 psig (5.5 bar) typical
<b>Function</b>	Normally-closed proportional
<b>Hysteresis</b>	±0.50% of full scale, max.
<b>LED Indicators</b>	Power (red) and command mode (blue—solid indicates analog, flashing indicates serial)
<b>Linearity</b>	±0.50% BFSL
<b>Material, Wetted</b>	Aluminum, nitrile, FKM, brass
<b>Medium</b>	Clean, dry, non-corrosive gases
<b>Monitor Signal Accuracy</b>	±0.30% of full scale
<b>Mounting Attitude</b>	Any
<b>Operating Pressure Range</b>	Vac to 150 psig (10.3 bar)
<b>Port Size</b>	1/4" NPT, G1/4
<b>Protection Rating</b>	IP65 (housed unit only)
<b>Resolution</b>	≤35 mV
<b>Response Time</b>	<20 ms typical (application dependent)
<b>Signal/Command</b>	<b>Electrical:</b> 0 to 5 or 0 to 10 VDC; 4 to 20 mA <b>Serial:</b> 3.3 VDC
<b>Supply Voltage</b>	15 to 24 VDC
<b>Temperature Range</b>	32 to 120°F (0 to 40°C), <i>proportional valve</i>
<b>More Details</b>	<a href="http://clippard.com/link/cordis-chv">clippard.com/link/cordis-chv</a>

Equipment used for testing and calibration is NIST traceable.

## Applications

- Pneumatic clutch and brake
- Test stands and production line equipment to control accurate test pressures
- Dancer arm tension control
- Nitrogen or other inert gas blanketing control
- Resistance welding tip force control
- Atomizing and fan control for painting and coating
- Low pressure with high accuracy and resolution at high flow
- Variable vacuum or vacuum through positive pressure control, either absolute or gauge reference

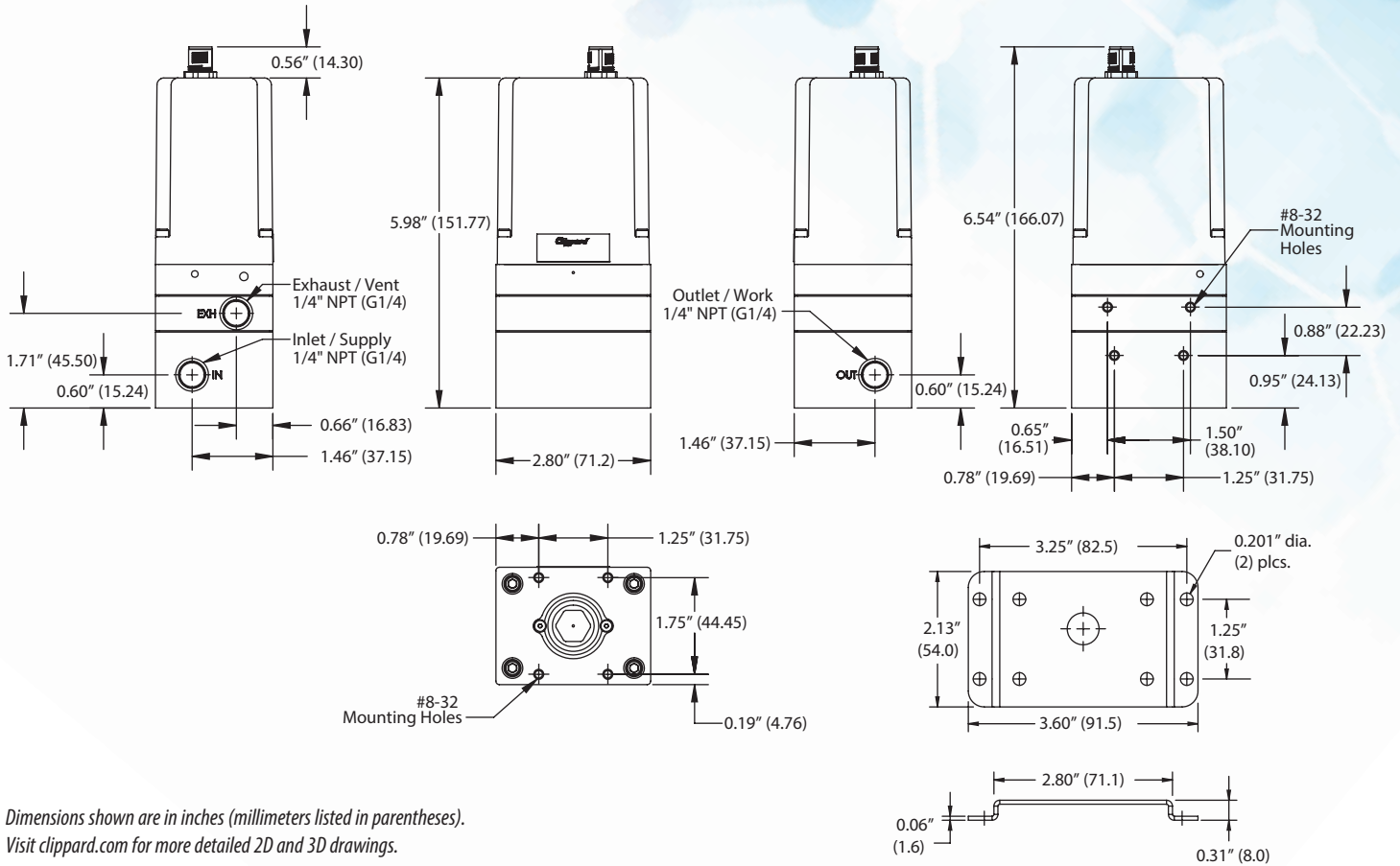

Dimensions shown are in inches (millimeters listed in parentheses).  
 Visit [clippard.com](http://clippard.com) for more detailed 2D and 3D drawings.

## ORDERING INFORMATION

# C H V - H     -

### Porting

- F 1/4" NPT
- G G1/4

### Voltage

- E 0 to 10 VDC
- R 3.3 VDC Serial
- I 4 to 20 mA
- F 0 to 5 VDC

### Calibrated Range

- |                 |                |                   |
|-----------------|----------------|-------------------|
| A 0 to 1 psig   | I 0 to 0,5 bar | O 0 to 15 psia    |
| B 0 to 5 psig   | J 0 to 1 bar   | P 0 to 30 psia    |
| C 0 to 15 psig  | K 0 to 2 bar   | Q 0 to 100 psia   |
| D 0 to 30 psig  | L 0 to 4 bar   | R -5 to +5 psid   |
| E 0 to 60 psig  | M 0 to 7 bar   | S -15 to +15 psid |
| F 0 to 100 psig | N 0 to 10 bar  | W -1 to +1 psid   |
| G 0 to 150 psig |                |                   |

Consult Clippard for more specific calibrations and units of measure, or to discuss the availability of non-standard commands and other options.

## ACCESSORIES

- CPCH-C1 Actuation Cable, 8-Pin, 6'
- CPCH-C2 3.3 VDC Serial Cable, 3'
- CPCH-B3 Mounting Bracket

### Example Part Number:

CHV-HFR-A

For more info, scan the QR code or visit [clippard.com/link/cordis-chv](http://clippard.com/link/cordis-chv)

