

# ALTERA

Coordinate Measuring Machines



...we are metrology

# ALTERA

# EXCELLENCE NOW

## Coordinate Measuring Machines

LK Metrology's range of premium quality ALTERA CMMs meet the varying needs of manufacturers, both today and in the future.

The superior ceramic design, with near perfect stiffness-to-weight ratio and greater resistance to temperature shifts, provides consistent performance across all manufacturing environments. Advanced multi-sensor ready technology optimizes CMM throughput and provides the opportunity to broaden the application scope to new materials and components as needs change. Innovative work-flows and intuitive software features facilitate complex inspection tasks and boost productivity.

### Unique accuracy guarantee

LK Metrology is the only manufacturer to guarantee the accuracy of its CMMs for 10 years.



Conditions apply, see LK Metrology website for full details.



### ✓ Enduring accuracy

Ultra-stable ceramic bridge and spindle guideway with high resolution 0.05  $\mu\text{m}$  optical scales for volumetric accuracies as low as  $0.7\mu\text{m}+L/600$ .

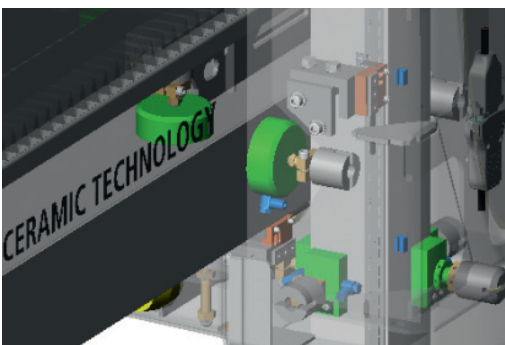

### ✓ Precise motion

Granite dove-tail table guideway with unique single orifice grooved pre-loaded air bearings for precise motion control at high speeds.

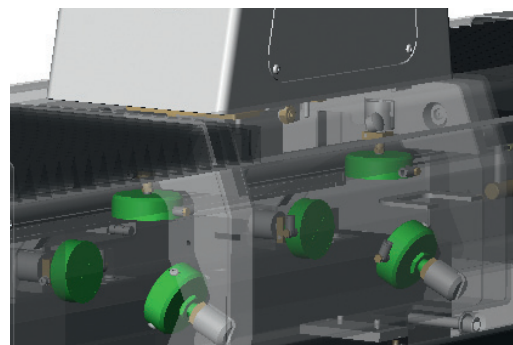

# AND IN THE FUTURE...



## ✓ Anti-vibration

Self-levelling vibration isolation for optimum performance in areas subject to high levels of low frequency vibration.



## ✓ Shop floor ready

CMM Automation for in-line and stand-alone shop floor measurement solutions with guideways protected from airborne contaminants.



# THE ALTERA FAMILY



With throughput, precision, multipurpose, shopfloor and custom options available, ALTERA is the most configurable CMM platform available for quality and process control measurement.

## ALTERA<sup>S</sup>

ALTERA S is a multipurpose CMM with the most advanced capabilities in the compact CMM class.

Innovative multi-sensor ready technology allows you to expand the capability of your CMM as your requirements change, and without expensive controller upgrades.

## ALTERA<sup>M</sup>

The ALTERA M range of performance CMMs deliver exceptional throughput and enhanced precision to the heart of your production. Exclusively designed for high speed tactile probe scanning and laser scanner applications, ALTERA M is the preferred choice for automotive and aerospace OEMs and other manufacturers of performance critical components.

## ALTERA<sup>SL</sup>

The ALTERA SL series of ultra-high accuracy CMMs achieve sub-micron\* accuracy.

Drawing on over 50 years of LK CMM experience, the ALTERA SL has been optimized for the most challenging tasks and highest precision. The innovative short-leg bridge design increases accuracy to the highest level for metrology laboratory equivalent measurement uncertainty.

\*ALTERA SL High Accuracy version



# PROBING OPTIONS

ALTERA CMMs offer unrivaled flexibility and the latest generation of multi-sensor probing, 5-axis heads and scanning technology, all tailored to your manufacturing work flow and production cycle times.



FREE Renishaw change rack and probe modules when purchasing a new LK CMM with PH10 probe head.

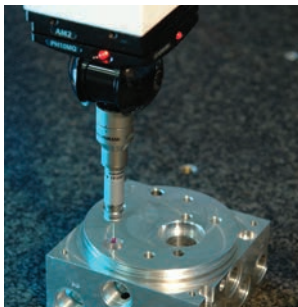

High accuracy TP200 touch trigger probe

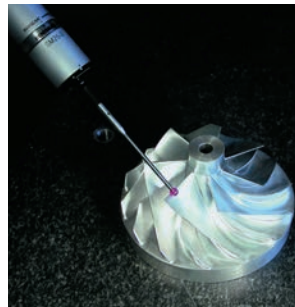

High speed SP25 scanning probe



High accuracy LC15Dx laser scanner



REVO 5-axis measurement system

Contact measuring systems					Non-contact measuring systems				
Manual		Motorized		Dynamic	Single and multi-stripe laser				
Manual probe heads with integral TP20 probe systems		Manual probe head with autojoint connection		Fixed position probe head with autojoint connection	Motorized probe heads with 720 positions available		Infinite positioning probe head	Motorized probe heads and complete range of digital technology laser scanners	
MH20i	MH20	MIH	PH6M	PH10T PLUS	PH10M PLUS	PH20	PH10M PLUS	L100	LC15Dx
RTP20	PH6M	TP20	TP200	TP20	SP25M	REVO-2			
				TP20	TP7M		LC60Dx	XC65Dx / XC65Dx-LS	

# SOFTWARE

Two software options, CMM-MANAGER or CAMIO, lets you choose the software package which best suits your needs. CMM-MANAGER is an easy to use software package with productivity focused intelligence and CAMIO is a powerful multi-sensor software package with advanced capability.

## **CAMIO8** Multi-sensor metrology software

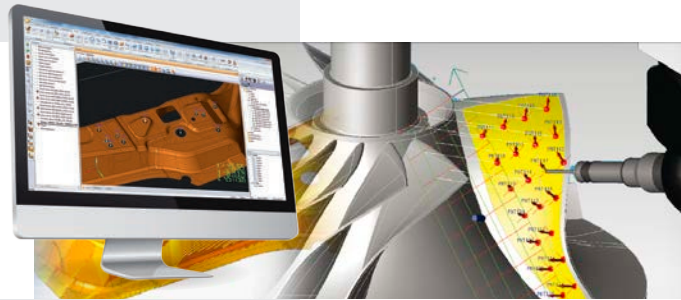

CAMIO is a comprehensive CMM software package, with advanced integrated multi-sensor capability for touch probes, scanning probes and laser scanning. Inspection programs and reports can be created for a wide range of common or specialist applications, both online or offline, using any popular CAD format.

## Advanced multi-sensor

- Industry standard DMIS inspection programs
- Inspect geometric features and full freeform surfaces
- Supports popular CMMs and probe systems via I++ protocol
- Intuitive workflows and powerful ribbon-style interface
- Touch probe, scanning probe and laser scanner integration
- Graphical reporting with SPC and Q-DAS link
- Gear and blade application software
- Production line automation

## **CMM-MANAGER** Metrology software for CNC, manual and portable CMM



CMM-MANAGER has been developed to make every step of CMM measurement and reporting as streamlined as possible.

## Easy to use productivity

- Walk in, measure and report quick start dimensional checks
- Optimized measurement and probe selection using a single click
- Intelligent graphical reporting with easy-to-understand output formats
- Real-time work piece and probe simulation with smart collision avoidance
- Web-ready reporting for convenient report distribution to a wider audience

# CMM software

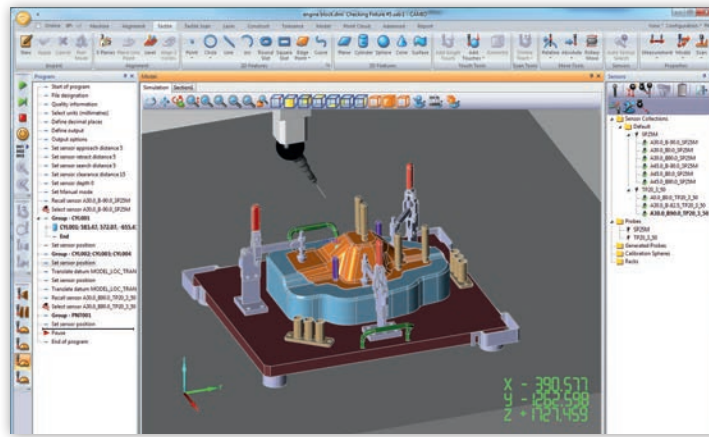
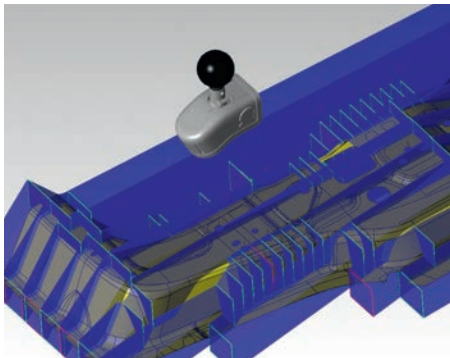

## Virtual simulation

CAMIO's powerful CMM programming environment provides full simulation for CMM, work piece and sensor. CMM programs can be optimized and verified for maximum efficiency before the arrival of work piece samples. Reports can be prepared and customized to meet customer specific formats ahead of time for maximum CMM uptime.



# focused CMM software

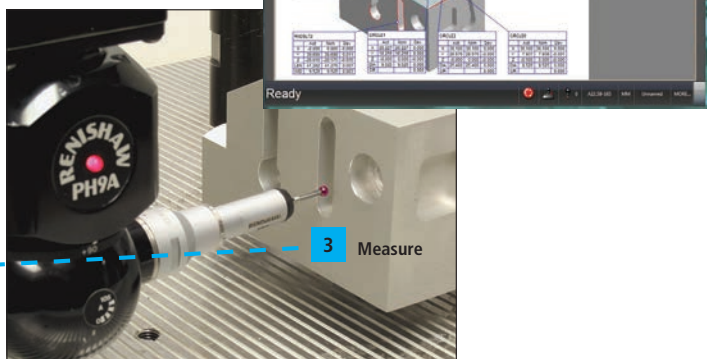
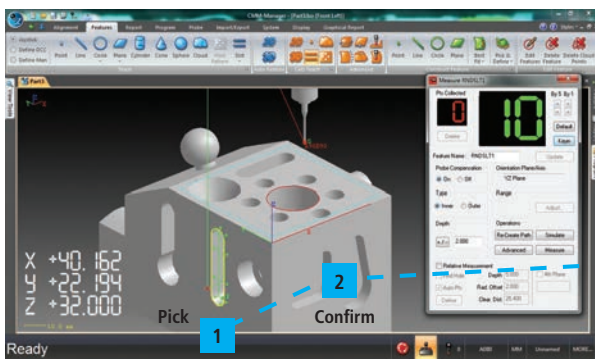

## Click-and-measure

Using CMM-Manager's click-and-measure capability, the operator is able to pick any feature on the CAD model. The software automatically selects the proper probing angle and generates a collision-free path. After the operator confirms the selection, the CMM automatically measures the feature.

# SPECIFICATIONS



## Measuring Volume

### ALTERA<sup>S</sup>

<b>7.5.5</b>	<b>8.7.6</b>	<b>10.10.8</b>
	<b>10.7.6</b>	<b>12.10.8</b>
	<b>15.7.6</b>	<b>15.10.8</b>
	<i>20.7.6</i>	<b>20.10.8</b>
	<i>25.7.6</i>	<i>25.10.8</i>

### ALTERA<sup>M</sup>

<b>8.7.6</b>	<b>10.10.8</b>	<i>10.12.10</i>	<i>15.15.10</i>	<b>20.15.12</b>	<b>20.15.15</b>	<b>25.20.15</b>
<b>10.7.6</b>	<b>15.10.8</b>	<b>15.12.10</b>	<b>20.15.10</b>	<b>25.15.12</b>	<b>25.15.15</b>	<b>30.20.15</b>
<i>15.7.6</i>	<b>20.10.8</b>	<b>20.12.10</b>	<b>25.15.10</b>	<b>30.15.12</b>	<b>30.15.15</b>	<b>35.20.15</b>
	<b>25.10.8</b>	<b>25.12.10</b>	<b>30.15.10</b>	<b>35.15.12</b>	<b>35.15.15</b>	<b>40.20.15</b>
	<i>30.10.8</i>	<b>30.12.10</b>	<b>35.15.10</b>	<i>40.15.12</i>	<b>40.15.15</b>	<i>45.20.15</i>
	<i>35.10.8</i>	<i>35.12.10</i>	<i>40.15.10</i>	<i>45.15.12</i>	<i>45.15.15</i>	<b>50.20.15</b>
	<i>40.10.8</i>	<i>40.12.10</i>	<i>45.15.10</i>	<i>50.15.12</i>	<i>50.15.15</i>	<b>60.20.15</b>
	<i>45.10.8</i>	<i>50.12.10</i>	<i>50.15.10</i>	<i>60.15.12</i>	<i>60.15.15</i>	<i>65.20.15</i>
		<i>60.12.10</i>	<i>60.15.10</i>	<i>70.15.12</i>	<i>70.15.15</i>	<i>70.20.15</i>
		<i>70.12.10</i>	<i>70.15.10</i>			

### ALTERA<sup>SL</sup>

<b>8.7.6</b>	<b>10.10.8</b>	<b>15.12.10</b>	<b>25.15.10</b>	<b>20.15.15</b>	<b>25.20.15</b>
<b>10.7.6</b>	<b>15.10.8</b>	<b>20.12.10</b>		<b>25.15.15</b>	
<b>15.7.6</b>	<b>20.10.8</b>	<b>25.12.10</b>			
	<b>25.10.8</b>				

### ALTERA<sup>SLHA</sup>

<b>8.7.6</b>	<b>10.10.8</b>	<b>15.12.10</b>
<b>10.7.6</b>	<b>15.10.8</b>	<b>20.12.10</b>
<b>15.7.6</b>	<b>20.10.8</b>	<b>25.12.10</b>
	<b>25.10.8</b>	

## Performance

	ALTERA <sup>S</sup>	ALTERA <sup>M</sup>	ALTERA <sup>SL</sup>	ALTERA <sup>SLHA</sup>
Volumetric accuracy	from 1.8 µm + L/400	from 1.5 µm + L/375	from 1.1 µm+L/400	from 0.7 µm+L/600
Repeatability	from 1.7 µm	from 1.5 µm	from 0.7 µm	from 0.5 µm
Velocity	from 762 mm/s	from 833 mm/s	up to 850 mm/s	up to 317 mm/s
Acceleration	from 2,306 mm/s <sup>2</sup>	from 2,514 mm/s <sup>2</sup>	up to 1,407 mm/s <sup>2</sup>	up to 566 mm/s <sup>2</sup>

Full CMM specifications available on request, contact LK Metrology for more information.  
CMM sizes printed in bold font are standard sizes. CMM sizes in italic font are available on request.



**LK METROLOGY Ltd.**  
Argosy Road, East Midlands Airport,  
Castle Donington, Derby,  
DE74 2SA United Kingdom  
Tel: +44 (0)1332 811138  
Email: Sales.UK@LKmetrology.com

**LK METROLOGY Inc.**  
29550 W. K. Smith Drive, Unit B  
New Hudson, MI 48165  
United States  
Tel: +1 (810) 263 6100  
Email: Sales.US@LKmetrology.com

**LK METROLOGY China Co. Ltd.**  
Room 401, HuaTeng Building, No. A302,  
Jinsong 3rd Zone, Chaoyang District, Beijing,  
P.R. of China.  
Tel: +86 10 87768860  
Email: Sales.China@LKmetrology.com

**LK METROLOGY Europe S.r.l.**  
Corso Orbassano, 402/16  
10137 Torino, Italy  
Tel: +39 011 0743945  
Email: Sales.Italy@LKmetrology.com

**LK METROLOGY Benelux**  
Technologielaan 11,  
3001 Leuven, Belgium  
Tel: +32 (0)16 387550  
Email: Sales.Belgium@LKmetrology.com

**LK METROLOGY GmbH**  
Siemensstrasse 24,  
D-63755 Alzenau, Germany  
Tel: +49 6023 9292617  
Email: Sales.Germany@LKmetrology.com

**LK METROLOGY SAS**  
1 Rue Guynemer - Bâtiment B6/B8  
78114 Magny Les Hameaux (Paris)  
Tel: +33 (0)1 77048480  
Email: Sales.France@LKmetrology.com

[www.LKmetrology.com](http://www.LKmetrology.com)