

FAIRBANKS®

SCALES



FB7100 SERIES

TOUCH SCREEN INSTRUMENT

Fairbanks most intuitive and easy-to-operate instrument for mid-range, single scale, truck or railcar weighing. Economical price, standard touch screen, optional single set-point filling, and no hassle set-up.

FB7100 SERIES

TOUCH SCREEN INSTRUMENT

• Designed for single scale, mid-range truck or railcar applications • Single setpoint filling option

In today's ever increasingly efficient world, there is increased demand for efficient vehicle weighing instrumentation that is intuitive, easy-to-use, and self-diagnostic. In response to this challenge, Fairbanks engineers developed the FB7100 Series Instrument, a mid-range truck and rail scale instrument that checks all those boxes and so many more. Scale operators will save time and increase productivity thanks to the FB7100's lightning-fast functionality, touchscreen interface, standard remote scale

configuration, calibration and 24/7 diagnostics (via any web browser). Moreover the FB7100 is commercially approved for all legal-for-trade applications. All this at a price that's so economical it blows away the competition.

For more than 190 years, Fairbanks Scales has engineered and built cutting-edge weighing equipment. We continually combine our experience and expertise with the latest technology in order to offer the next best scale innovation to our weighing customers worldwide.

NEMA 12 Desktop Enclosure



The super compact NEMA 12 desktop enclosure is designed to support a Fairbanks ticket printer for additional space savings.

NEMA 4X Desktop/Wallmount Enclosure



Each enclosure is available with analog or Intalogix® load cell communications to fit operational requirements.

Easy operation and three robust operating modes

The FB7100 Series is the economical choice for high-traffic vehicle weighing applications that require instrument features and functions for gross/tare/net, inbound/outbound or basic in/out operating modes. Housed in a sleek and sturdy desktop or washdown

enclosure, the FB7100 has a large, full-color graphic display, touchscreen functionality with oversized keys, and easy-to-see weight values. Button functionality changes for each operating mode to maximize the space on the instrument's front panel.

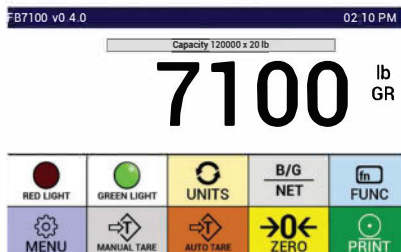

Gross/Tare/Net

GTN mode allows the scale operator to process weighments with or without the use of a keyboard-entered Tare or Autotare by simply pressing the PRINT key.

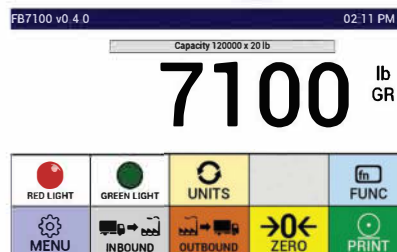

Inbound/Outbound

This mode allows the operator to weigh an inbound vehicle and store the transaction temporarily using a numeric Loop ID. When the vehicle returns to the scale to exit the facility, simply press the OUTBOUND key to recall the Inbound weighment and complete the transaction with Gross, Tare and Net values.

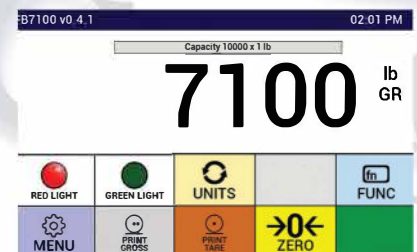

Basic In/Out

Basic In/Out mode is designed for applications in which no calculated NET weight is desired. After entering the scale, a loaded vehicle's weight is captured by pressing the PRINT GROSS button — an empty vehicle is captured by pressing the PRINT TARE button.

FB7100 Communications and Connectivity

The FB7100 contains all the necessary components to fulfill the needs of a modern, highly connected scale house. Standard RS232C ports allow for continuous or polled output to a personal computer, and a standard Ethernet TCP/IP port allows for continuous output over a new or existing network.

In addition to typical manufacturer output strings, this instrument features fully customizable strings that allow the use of almost any software.

The FB7100 is also a perfect standalone instrument, capable of processing and storing up to 10,000 transactions. Reports can be downloaded through a web interface or saved to a USB drive for record keeping. Traffic light controls, a programmable remote switch interface, simple ticket formatting, and many more features are easily configured and managed through the instrument. It is the perfect choice whether you are replacing an outdated instrument, building a new scale, or just looking to upgrade your operation.

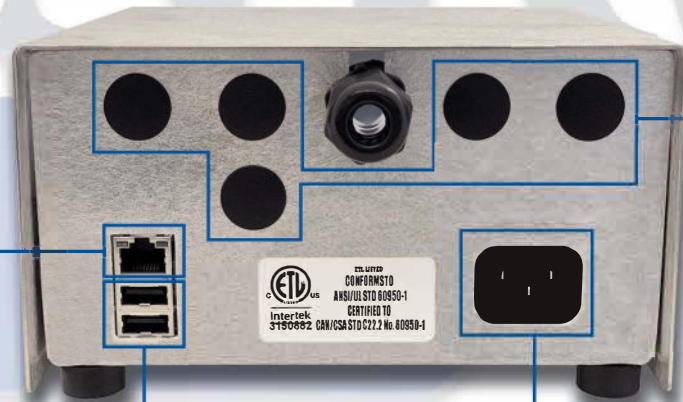

One Ethernet TCP/IP port for providing weight data over network connections and accessing the FB7100 Web Utility

COM ports and Accessories Interfaces

- Two RS232 serial ports
- 20 mA active or passive
- Four programmable remote switch inputs
- 4-20 mA, relay interface, serial expansion, or PLC interface expansion
- ACC 165 relay box

Two USB 2.0 ports for connecting a USB keyboard or external flash drive

Power cord connection 100-240 VAC



FB7100 Instruments are Legal for Trade!

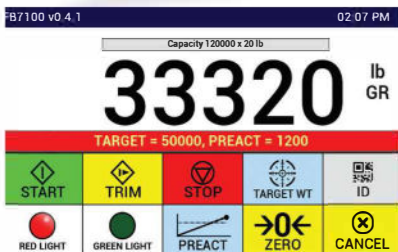

Add a Fairbanks ACC 165 relay box to run your single setpoint material filling operation.

Single setpoint material filling in any operating mode

The FB7100 supports a single setpoint when used with the ACC 165 relay box. This mode will benefit any site filling single materials for transport, allowing for the control to be integrated into the weighing process. The setpoint can be used in any of the three operating modes and will slide seamlessly into the existing cycle of operation. A setpoint menu featuring oversized START/TRIM/STOP keys and direct target weight entry leads to an intuitive flow that makes training operators quick and easy.

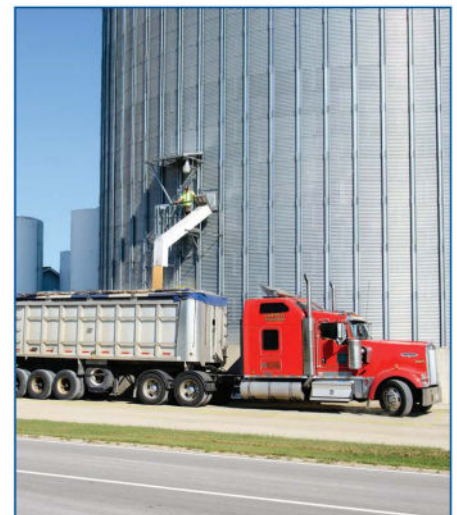

FB7100 SERIES TOUCH SCREEN INSTRUMENT

Weighing Solutions for the World Since 1830

Fairbanks.com

SPECIFICATIONS

Enclosure Stainless steel and aluminum desktop NEMA 12,
Stainless steel desktop/wall mount NEMA 4X

Processor 900 MHz

Memory 512 MB RAM, 512 MB Flash

Display Full color graphic touch screen,
800 x 480 resolution, TFT LCD with LED backlight,
4.25" x 2.55", 5.0" diagonal (NEMA 12 enclosure)
6.04" x 5.17", 7.0" diagonal (NEMA 4X enclosure)

Touch screen Standard

Displayed characters . . . 5/8" tall

Outputs One (1) RJ45 10/100 Base-T Ethernet port
Two (2) RS232C ports
Two (2) USB 2.0 ports
One (1) dedicated optically
isolated 20mA (active or passive)

Power requirements . . . 100 to 240 VAC @ 47-63 Hz

Clock Real time clock, Day of the week,
12-hour am/pm, Date (month/day/year)

Display resolution 10,000 divisions commercial
50,000 divisions non-commercial

Capacity Programmable to 999,999

Division size 0.0001 to 100

Displayed units 6 primary and 6 secondary

Programmable prompts . . One (1)

Number of scales One (1)

Stored tares 1,000

Transaction records 10,000

Calibration & configuration Parameters can be configured locally at the instrument or remotely using an ethernet connection and standard browser

Humidity 0 to 90% NEMA 12, 0 to 100% NEMA 4X

Accuracy Class III/IIIL

Accessories 4-20 mA (Passive, 16 bit),
4-20 mA (Active, 16 bit),
Serial expansion card with four additional outputs per card:
One (1) RS232C
One (1) RS232C/485 selectable
One (1) RS232/20mA selectable
One (1) RS485
Traffic light control card
PLC interfaces:
DeviceNet
Ethernet/IP
Modbus TCP
Peripheral devices:
Ticket printer, tape printer, form printer
remote displays, traffic light, control box,
105 key QWERTY keyboard,
87 key QWERTY keyboard

Approvals NTEP CC# 19-146, MC# AM-6141, ETL

DIMENSIONS

Desktop NEMA 12 Enclosure

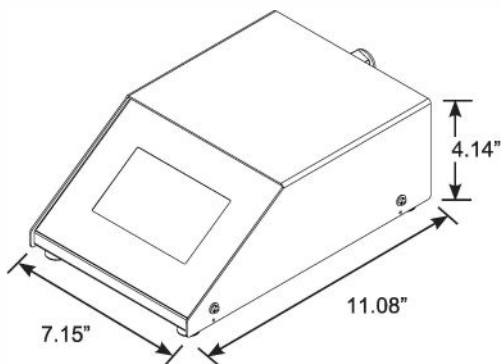

Desktop/Wall Mount NEMA 4X Enclosure

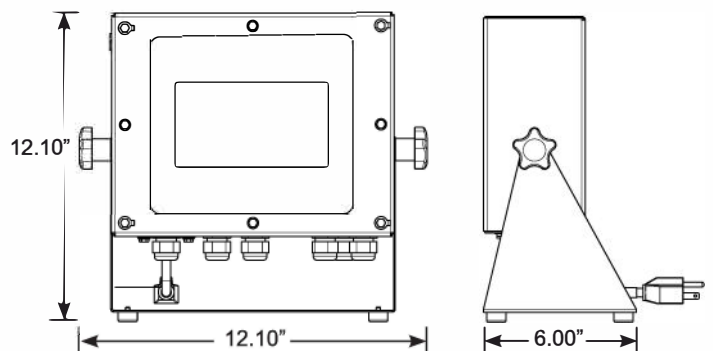

Your Fairbanks Scales Authorized Representative is:

