



CORDIS SERIES

High Resolution Proportional
Pressure Controllers

Operating Instructions



CPC-H



CPC-C

The Cordis is a closed-loop pressure control valve system designed to maintain a steady and repeatable downstream pressure as demand or process changes occur. Cordis is available in a compact card style (CPC-C) or with an IP65 rated enclosure (CPC-H) for manufacturing and industrial environments. Both styles come standard with two Clippard proportional electronic valves designed for high resolution pressure control.

Content

2	Technical Data	Serial Connection - CPC-C	14
2	Operational Description	Serial Connection - CPC-H	15
3	Mounting	Flow & Orifice Selection	16
3	Pneumatic Plumbing	Ordering Information & Cables	17
3	Safety & Best Practices	Accessories - Mounting Bracket	18
4	Calibration	Dimensions - CPC-C	18
4	Recalibration	Dimensions - CPC-H	19
5-8	Electrical Connection	Contact Information	20
9	Serial PuTTY Configuration	Limited Warranty	20
10-13	Serial Configurations	Other Useful Material Links	20
13	Serial Commands	clippard.com/link/cordis	

Technical Data

Table:1

ELECTRICAL	
Voltage	15 to 24 VDC
Current Draw	< 250 mA max.
Signal/Command	<i>Electrical:</i> 0 to 10 VDC or 4 to 20 mA <i>Serial:</i> 3.3 VDC

PERFORMANCE	
Accuracy	± 0.25% of full scale
Resolution	≤ 5 mV
Linearity	± 0.05% BFSL
Max. Hysteresis	± 0.05% of full scale
Typical Flow	See Page 16
Response Time	< 20 ms typical (<i>application dependent</i>)

OPERATING CONDITIONS	
Operating Temp. with Digital Valve	32 to 180°F (0 to 82°C)
Operating Temp. with Proportional Valve	32 to 120°F (0 to 49°C)
Medium	Clean, dry, non-corrosive gases
Mounting Attitude	Any
Process Connections	1/8" NPT or G1/8

WETTED MATERIALS	
Elastomers	Nitrile
Manifold	Anodized aluminum
Valves	Nickel plated brass
Pressure Sensor	High temperature polyamide, alumina ceramic, silicone epoxy, glass
IP65 Housing	Polycarbonate

MORE DETAILS	
Website	clippard.com/link/cordis

Operational Description

The Cordis is designed to accept a pressure on the inlet port, reduce it and control to a user-specific set pressure on the work port. Both the CPC-C and CPC-H models contain a microcontroller, integrated pressure sensor, and two Clippard proportional valves. The CPC-H model also includes an IP65 enclosure for industrial environments.

For Cordis to control pressure in your process, a regulated supply pressure should be connected to the inlet valve (I). The outlet valve (O) should be connected to the downstream process and the exhaust port (E) should be open to atmosphere. As the command signal increases the inlet valve opens to allow pressure downstream. This pressure passes over the internal sensor element which is constantly providing active feedback to the microcontroller. As soon as this feedback matches the user-specified command, the inlet valve closes and holds the commanded pressure downstream. If at any point the sensor measures a higher value (backpressure) than the setpoint or if the user-specified command is lowered, the exhaust valve will modulate open and vent off the excess pressure to maintain stable and accurate pressure control in the process. Likewise, if dynamic conditions exist or if any consumption occurs downstream, the inlet valve will open and instantly compensate to maintain the desired downstream setpoint.

Mounting

The Cordis series can be mounted in any orientation without negatively affecting process control. Both the CPC-C and CPC-H models come standard with convenient (top-down) mounting holes for easy mounting to most flat surfaces. In addition to this, a mounting bracket that doubles as a rear-mount or foot-mount is available for the CPC-H model. Please refer to Page 17 for more information on this mounting bracket.

CPC-C Pneumatic Plumbing

Inlet Port (IN)

Outlet Port (OUT)

Exhaust Port (EXH)

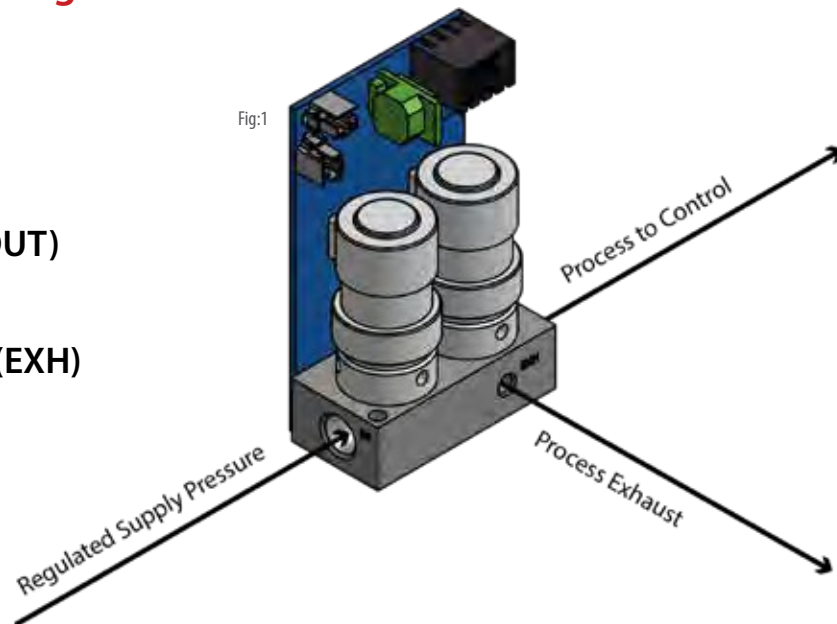

Safety & Best Practices

- ⚠ **Recommended filtration for supply media is 40 micron or better.**
- ⚠ **Supply pressure must be regulated to \leq max pressure allowed for calibrated range. See Table: 2 & 3**
- ⚠ **Disconnect power if supply pressure is not connected.**
- ⚠ **CPC-C 10-32 exhaust port should face seal, no thread sealant required.**
- ⚠ **When changing fittings, thoroughly clean all tape and/or debris from the port connections.**
- ⚠ **Inlet pressure must be a minimum of 10% above max calibrated range of Cordis to achieve max output.**
- ⚠ **Captured exhaust media must be able to vent to atmosphere.**
- ⚠ **Preferred sealant for 1/8" NPT ports is Loctite 545 or face seal. If thread tape is required, make sure to start wrap after the first two threads to reduce the possibility of valve contamination.**
- ⚠ **Always take precautionary measures while handling exposed circuit boards: Hold circuit board on edges whenever handling device. Store device in antistatic bag to prevent possible ESD from damaging**

Calibration

The calibration of the Cordis series is done at the time of manufacture to NIST traceable standards. Each unit is calibrated and the PIDs are set to the Cordis standard tuning. If a customer's specific application details are known prior to manufacture (recommended), the PIDs will be tuned in accordance with the known specifications to provide the most stable and repeatable control. Below are the available calibration ranges and maximum allowed inlet pressure for each range.

Table:2 **Rated Inlet Pressure for Calibrated Range (psig)**

CALIBRATED RANGE	MAX. INLET PRESSURE
0 to 1 psig	10 psig
0 to 5 psig	30 psig
0 to 15 psig	30 psig
0 to 30 psig	60 psig
0 to 60 psig	100 psig
0 to 100 psig	115 psig
0 to 150 psig	165 psig
0 to 15 psia	10 psig
0 to 30 psia	45 psig
0 to 100 psia	165 psig
-5 to +5 psid	25 psig
-15 to +15 psid	45 psig
0 to 10" H2O	5 psig
-10" to +10" H2O	6 psig
0 to 4" H2O	4 psig
-1 to +1 psid	8 psig

Table:3 **Rated Inlet Pressure for Calibrated Range (bar)**

CALIBRATED RANGE	MAX. INLET PRESSURE
0 to 0,1 bar	0,70 bar
0 to 0,5 bar	2 bar
0 to 1 bar	2 bar
0 to 2 bar	4 bar
0 to 4 bar	7 bar
0 to 7 bar	8 bar
0 to 10 bar	11 bar

Recalibration

The Cordis series does not require recalibration during its lifetime. If the calibration needs to be changed and/or modified, the unit must be returned to Clippard or completed by a certified field technician. Any attempt to recalibrate in the field without prior authorization will void the warranty.

Please contact Clippard for all Return Material Authorization (RMA) requests:

Clippard

7390 Colerain Avenue | Cincinnati, OH 45239 | sales@clippard.com | 1-877-245-6247

Please have the serial number(s) available for reference.

0 to 10 VDC Electrical Connection | CPC-C



Make sure AC power is disconnected before DC connections are made

The Cordis requires 15 to 24 VDC on **Pin 1** of the electrical connector. It uses 0 to 10 VDC command signal on **Pin 3** of the electrical connector. The power supply ground, command source ground and **Pin 2** must be tied together. If the analog monitor signal is being used, utilize **Pin 4** to send the 0 to 10 VDC signal to a measuring device like a volt meter, panel meter or acquisition device.

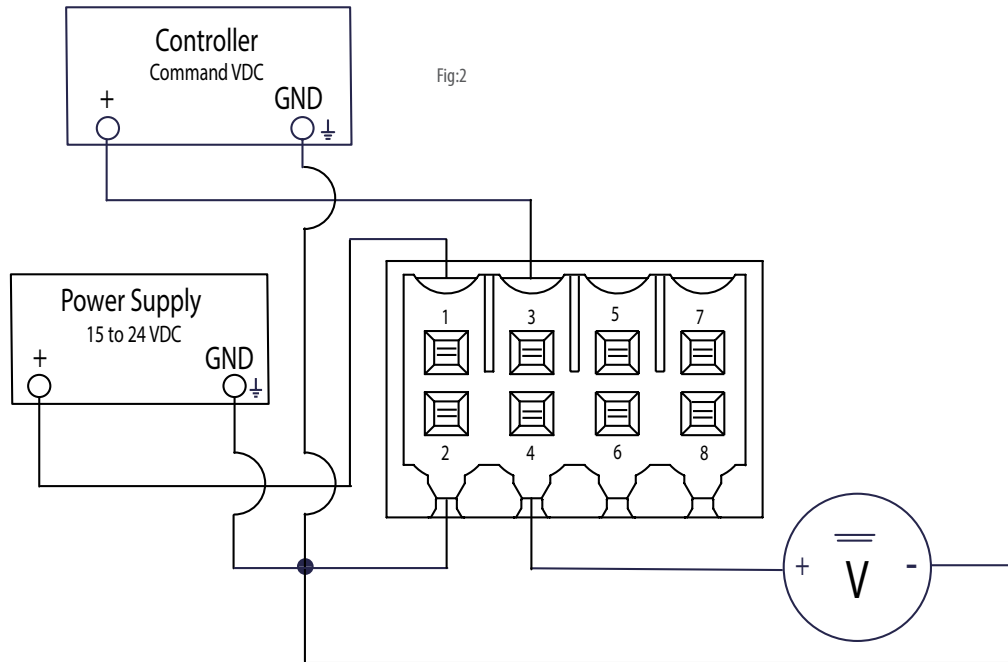
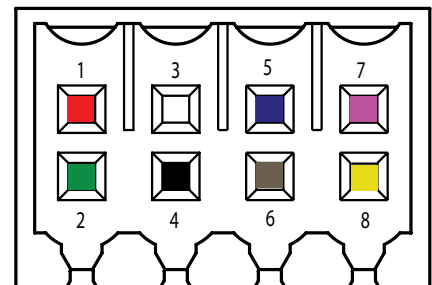

Table:4

CPC-C Model Electrical Pin-out

PIN NUMBER	FUNCTION	COLOR
1	Power, 15-24 VDC	Red
2	DC Common/Ground	Green
3	+Command Input	White
4	Analog VDC Output	Black
5	3.3 VDC Serial RX	Blue
6	3.3 VDC Serial TX	Brown
7	Not Used	Pink
8	Not Used	Yellow

Fig:3



4-20 mA Electrical Connection



Make sure AC power is disconnected before DC connections are made

The Cordis requires 15 to 24 VDC on **Pin 1** of the electrical connector. It uses 4 to 20 mA command signal on **Pin 7** of the electrical connector. Connect **Pin 8** to DC common or the negative 4 to 20 mA on the control module. If the analog monitor signal is being used, utilize **Pin 4** to send the 4 to 20 mA signal to a measuring device like a mA meter, panel meter or acquisition device.

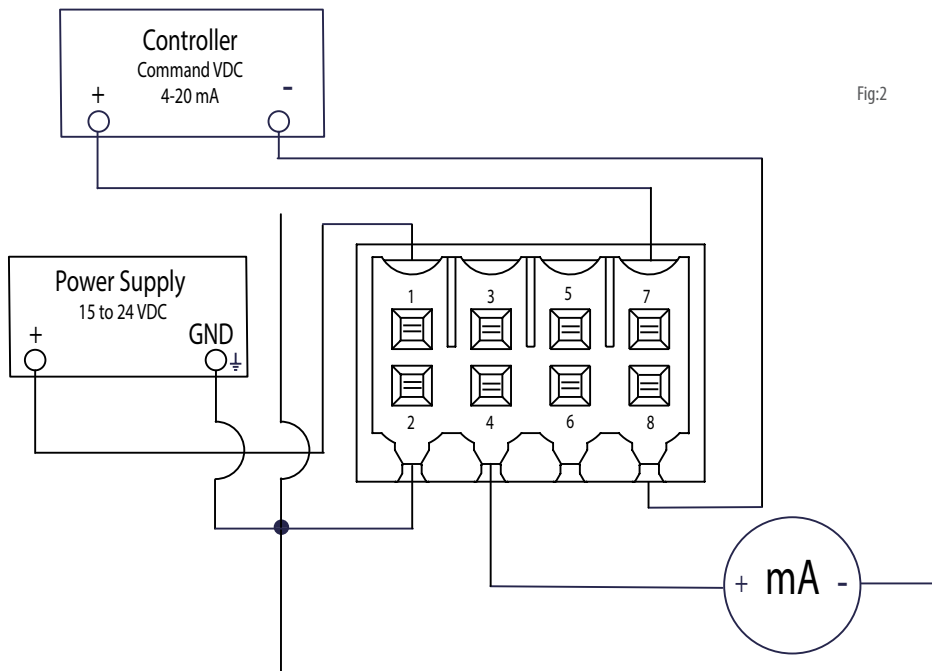

Fig:2

Table 4

CPC-C Model Electrical Pin-Out

PIN NUMBER	FUNCTION	COLOR
1	Power, 15-24 VDC	Red
2	DC Common/Ground	Green
3	n/c	White
4	4 to 20 mA Output	Black
5	3.3 VDC Serial RX	Blue
6	3.3 VDC Serial TX	Brown
7	+4 to 20 mA Command Input	Pink
8	-4 to 20 mA Command Return	Yellow

Fig:5

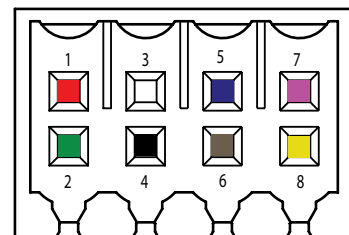

0 to 10 VDC Electrical Connection | CPC-H

⚠ Make sure AC power is disconnected before DC connections are made

The Cordis requires 15 to 24 VDC on **Pin 8** of the electrical connector. It uses 0 to 10 VDC command signal on **Pin 1** of the electrical connector. The power supply ground, command source ground and **Pin 3** must be tied together. If the analog monitor signal is being used, utilize **Pin 5** to send the 0 to 10 VDC signal to a measuring device like a volt meter, panel meter or acquisition device.

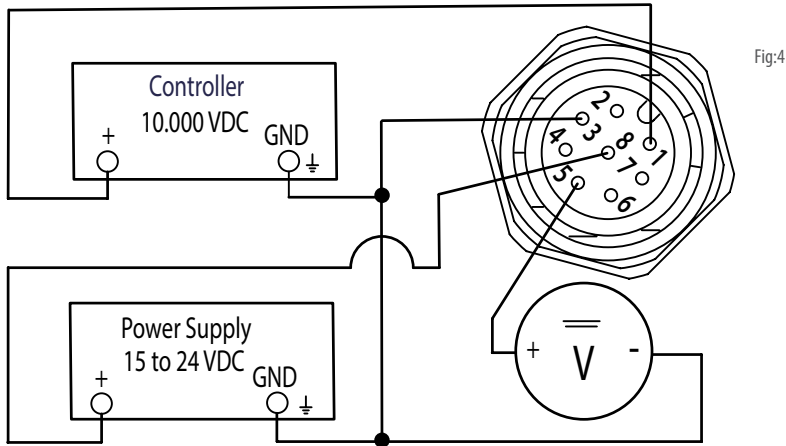
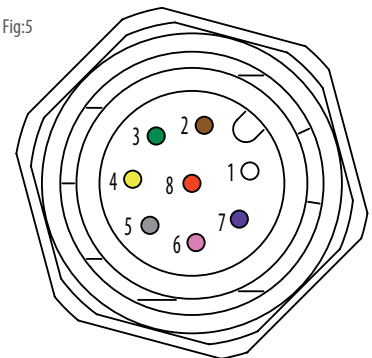

Table:5

CPC-H Model Electrical Pin-Out

PIN NUMBER	FUNCTION	COLOR
1	+Command Input	White
2	3.3 VDC Serial TX	Brown
3	DC Common/Ground	Green
4	Not Used	Yellow
5	Analog VDC Output	Gray
6	Not Used	Pink
7	3.3 VDC Serial RX	Blue
8	Power, 15-24 VDC	Red

Fig:5



4-20 mA Electrical Connection



Make sure AC power is disconnected before DC connections are made

The Cordis requires 15 to 24 VDC on **Pin 8** of the electrical connector. It uses 4 to 20 mA command signal on **Pin 6** of the electrical connector. Connect **Pin 4** to DC common or negative 4-20 mA on the control module. If the analog monitor signal is being used, utilize **Pin 5** to send the 4 to 20 mA signal to a measuring device like a mA meter, panel meter or acquisition device.

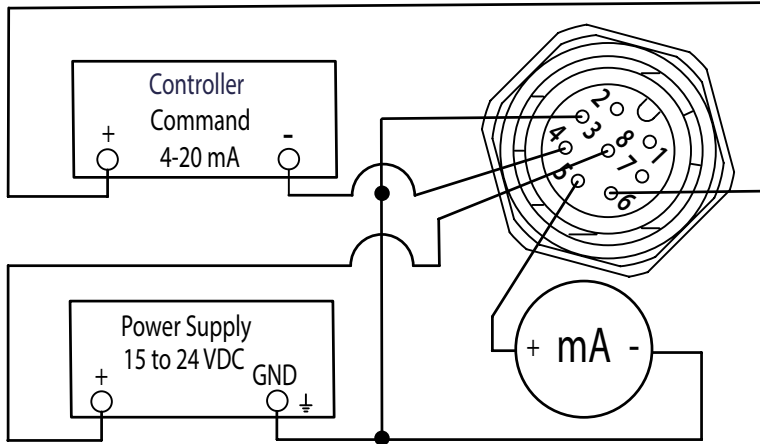

Fig:4

Table:5

CPC-C Model Electrical Pin-Out

PIN NUMBER	FUNCTION	COLOR
1	n/c	White
2	3.3 VDC Serial TX	Brown
3	DC Common/Ground	Green
4	-4 to 20 mA Command Return	Yellow
5	4 to 20 mA Output	Gray
6	+4 to 20 mA Command Input	Pink
7	3.3 VDC Serial RX	Blue
8	Power, 15-24 VDC	Red

Fig:5

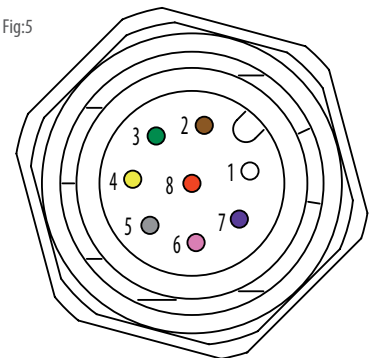

Serial Configuration



Cordis utilizes a 3.3 VDC communication signal

To communicate via Serial with the Cordis, software is required. Many serial software communication solutions are available. If you already have a software solution, please ensure it is configured with the specifications listed below (Table:6) prior to making the electrical connections to Cordis. The commands can be found on Page 13.

If you do not already have a serial software solution, we recommend PuTTY as a free and open-source solution. PuTTY is one of the most common software packages used for serial communication and can be downloaded here: <https://putty.org/>

Once downloaded and installed on your windows based machine, please follow the steps below to configure the software prior to making the electrical connections to Cordis. The specifications we will configure and/or confirm within PuTTY are listed in Table:6.

Table:6 **Serial Software Configuration (PuTTY)**

SETTING LABEL	SPECIFICATION
Speed (baud)	57600
Data Bits	8
Stop Bits	1
Parity	None
Flow Control	None
Serial Line	See Steps 1 & 2

Recommended Proportional Adjustment Values

ORIFICE SIZE	ADJUSTMENT
0.009"	25
0.013"	10
0.026"	5
0.052"	1
0.035"	5

Recommended Integral Adjustment Values

ORIFICE SIZE	ADJUSTMENT
0.009"	0.1
0.013"	0.05
0.026"	0.05
0.052"	0.05
0.035"	0.05

Serial Configuration | Continued

STEP - 1

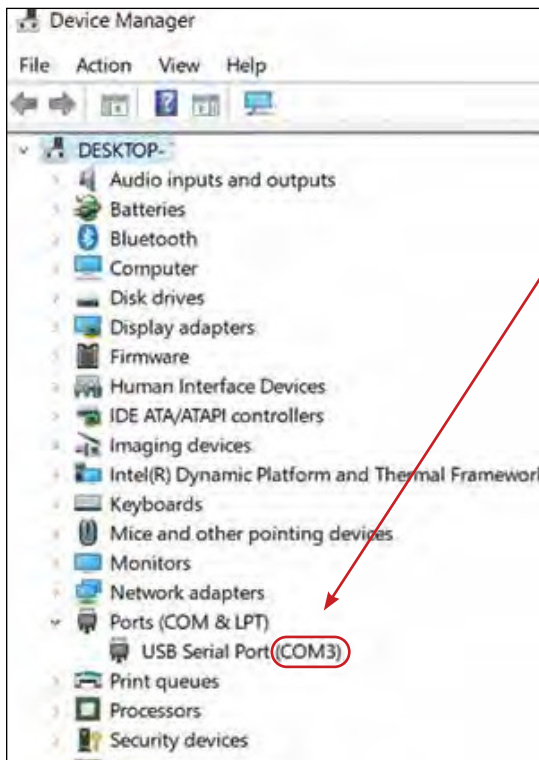

- 1) Ensure proper serial connection to Cordis unit and then connect 3.3 VDC serial to the control device. The wiring schematics can be found on pages 14 and 15.
- 2) Open Device Manager and identify the serial port assigned to the serial cable.

>>> Many ways to open Device Manager:

<https://www.digitalcitizen.life/ways-open-device-manager-windows>

STEP - 2

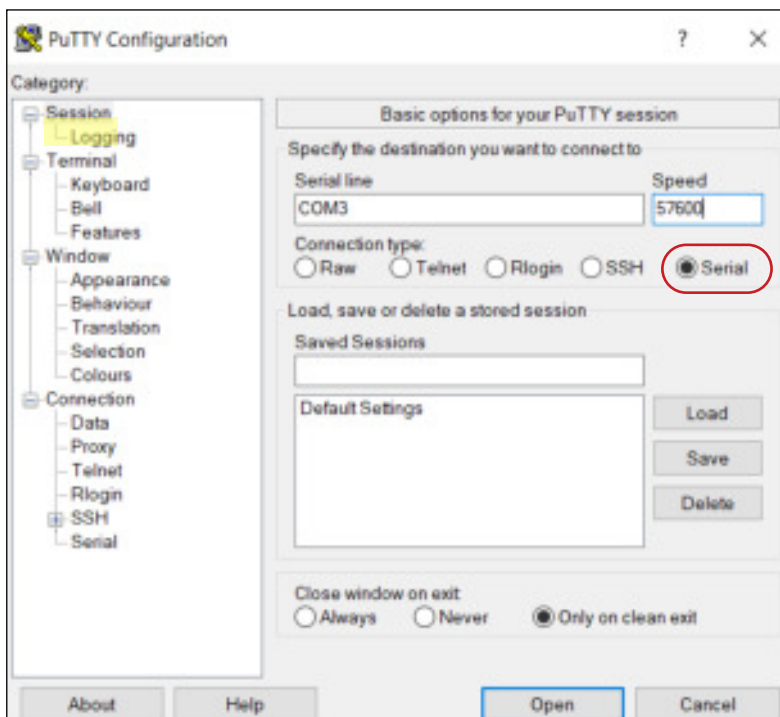

- 1) Open installed Putty program
- 2) Ensure 'Serial' is selected

Serial Configuration | Continued

STEP - 3

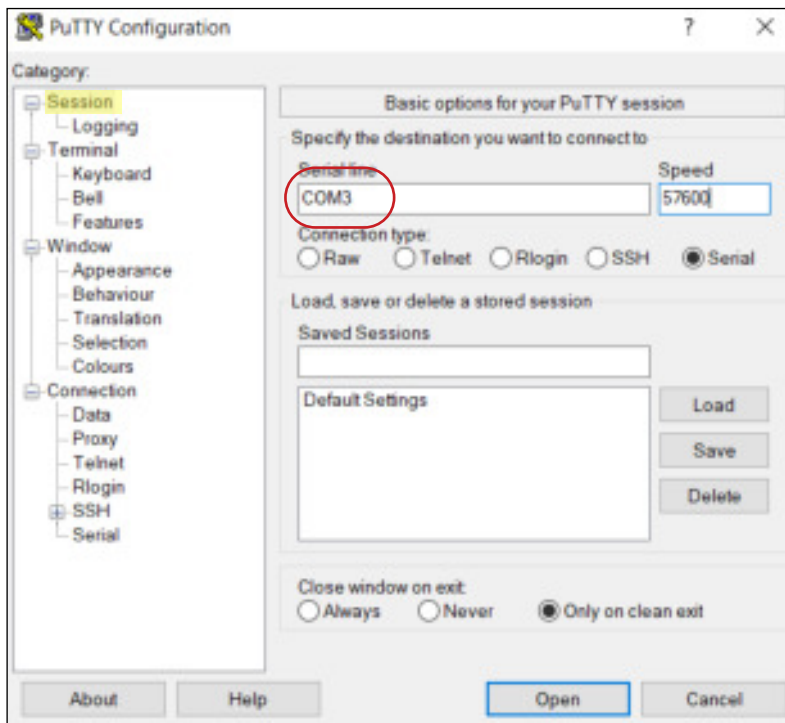

Input the port identified in Step - 1 into the Serial Line as shown.

STEP - 4

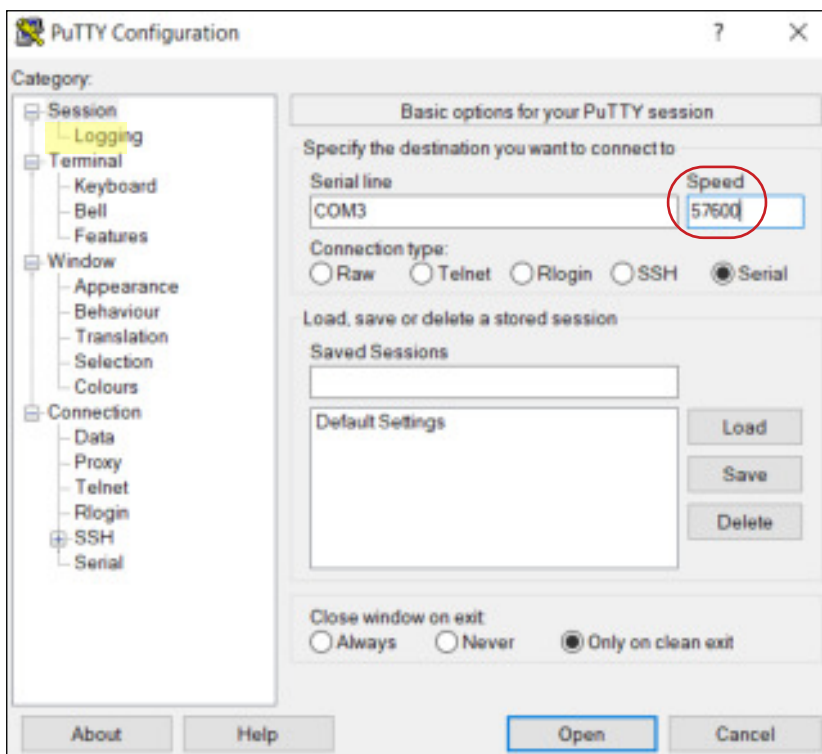

Change the speed (baud) setting to: **57600**

Serial Configuration | Continued

STEP - 5

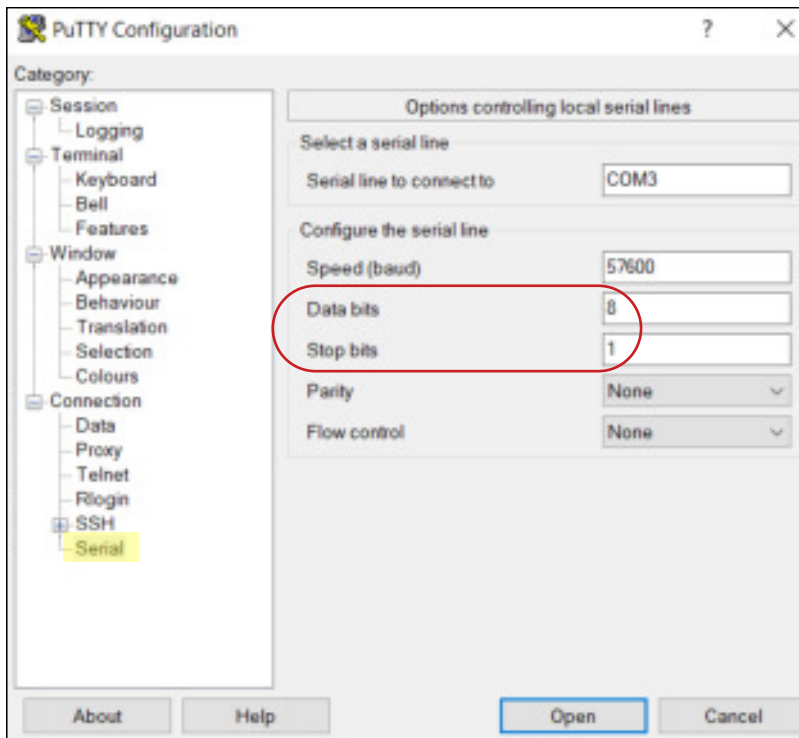

Change **Data Bits** to 8
and **Stop Bits** to 1

STEP - 6

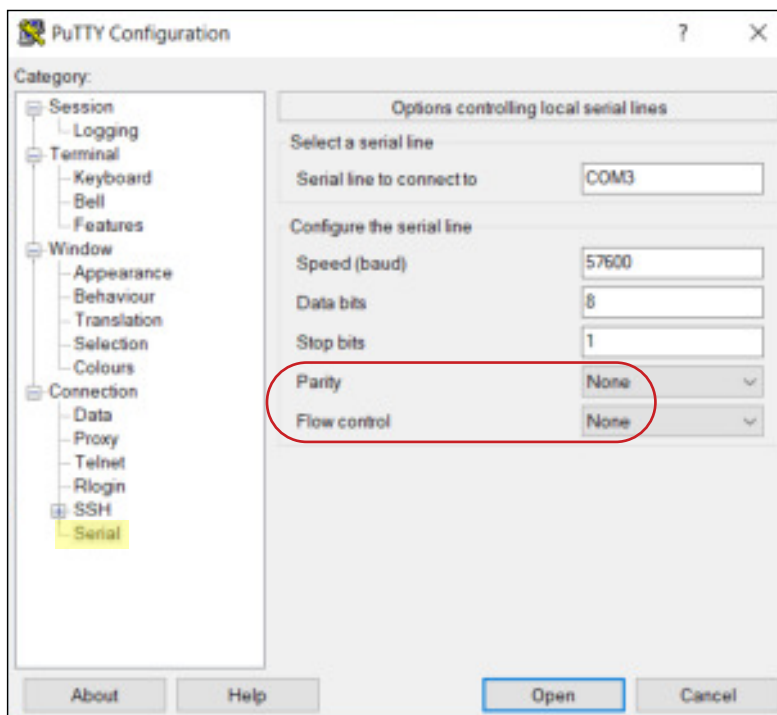

Ensure both **Parity** and **Flow Control** are set to **None**

Serial Configuration | Continued

STEP - 7

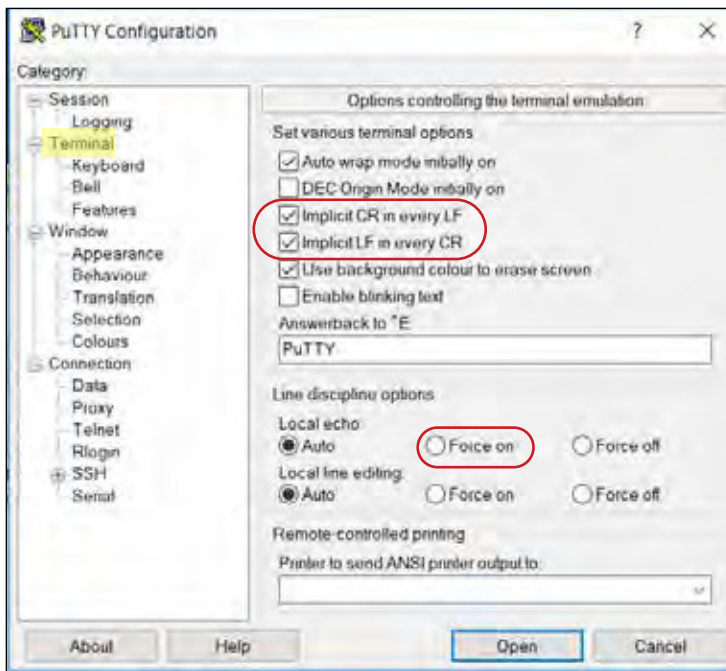

In Terminal settings, check the box for: **Implicit CR in every LF & Implicit LF in every CR**

STEP - 8

Once the Cordis is connected and the software is configured, the below commands (Table:7) can be used to change settings, request feedback and control the device.

Note: If you would like feedback as you type, set the Local Echo to "Force On"

Serial Commands

Table:7

Cordis | Serial Commands

DESCRIPTION	COMMAND ABBREVIATION	INSERT TO SEE CURRENT VALUES	INSERTED EXAMPLE CHANGES	READABLE	WRITABLE
Model No.	ID	?ID	n/a	Y	N
Serial Number	SN	?SN	n/a	Y	N
Proportional "P" Value	PIDP	?PIDP	PIDP: 100	Y	Y
Integral "I" Value	PIDI	?PIDI	PIDI: 0.75	Y	Y
Command Type (0=Analog, 1=Digital)	CT	?CT	CT: 1	Y	Y
Current Command (0 - 100% of Full Scale)	CC	?CC	CC: 50	Y	Y
Monitor Output Signal from Internal Sensor	MON	?MON	n/a	Y	N
Save Settings to ROM	SAVE	n/a	SAVE	N	Y



When entering all Reading Commands, always prefix with "?". Example: ?PIDP



Make sure to leave one space between the colon and value when making changes. Example: PIDP: 100

Serial Connection | CPC-C

⚠ Make sure AC power is disconnected before DC connections are made

The Cordis requires 15 to 24 VDC on **Pin 1** of the electrical connector. It uses serial communication on **Pin 5** to receive and **Pin 6** to send digital responses. The power supply ground, command source ground and **Pin 2** must be tied together.

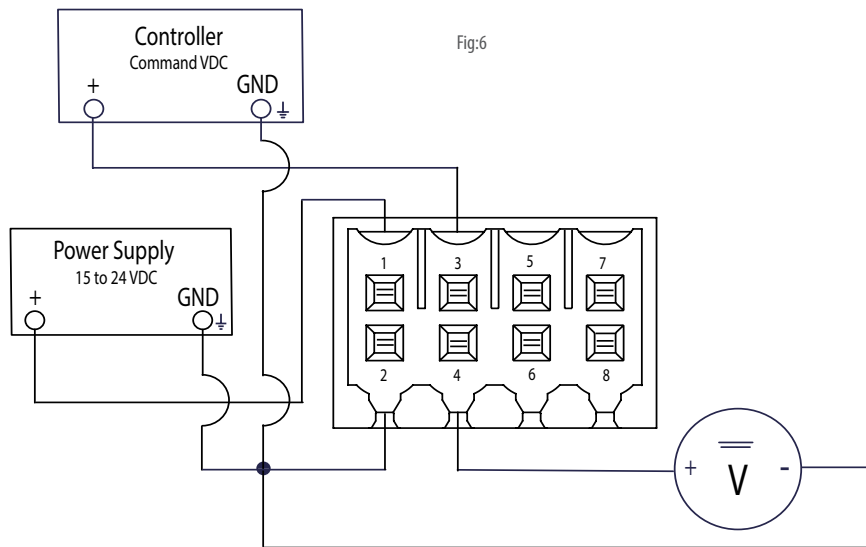

⚠ The 3.3 VDC host RX connects to the device TX. The 3.3 VDC host TX connects to the device RX. Be sure the 3.3 VDC host ground is common with the device ground.

Table:8

CPC-C Model Electrical Pin-out

PIN NUMBER	FUNCTION	COLOR
1	Power, 15-24 VDC	Red
2	DC Common/Ground	Green
3	+Command Input	White
4	Analog VDC Output	Black
5	3.3 VDC Serial RX	Blue
6	3.3 VDC Serial TX	Brown
7	Not Used	Pink
8	Not Used	Yellow

Fig:7

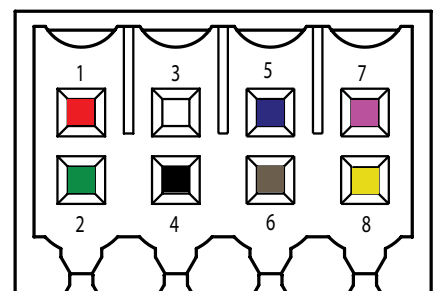

Serial Connection | CPC-H



Make sure AC power is disconnected before DC connections are made

The Cordis requires 15 to 24 VDC on **Pin 8** of the electrical connector. It uses serial communication on **Pin 7** to receive and **Pin 2** to send digital responses. The power supply ground, command source ground and **Pin 3** must be tied together.

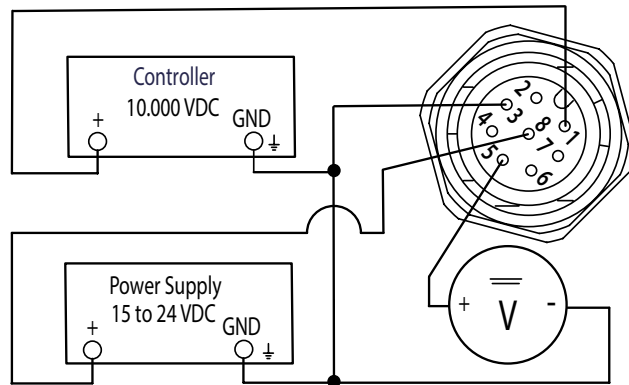

Fig:8

Table:9

CPC-H Model Electrical Pin-out

PIN NUMBER	FUNCTION	COLOR
1	+Command Input	White
2	3.3 VDC Serial TX	Brown
3	DC Common/Ground	Green
4	Not Used	Yellow
5	Analog VDC Output	Gray
6	Not Used	Pink
7	3.3 VDC Serial RX	Blue
8	Power, 15-24 VDC	Red

Fig:9

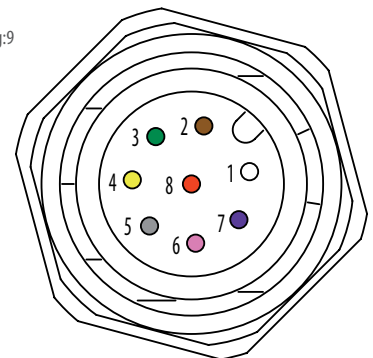

Flow & Orifice Selection

Table:10

Internal Valve Flow & Limitations

PN REF.	ORIFICE SIZE	FLOW @ MAX. PRESSURE	MAX. PRESSURE (P2)	MIN. CRITICAL VOLUME
A	0.009" EVP	2.7 l/min (5.72 scfh)	150 psig (10,34 bar)	≥ 0.25 in ³
B	0.013" EVP	6.7 l/min (14.2 scfh)	100 psig (6,89 bar)	≥ 0.50 in ³
C	0.026" DVP	25.0 l/min (53.0 scfh)	100 psig (6,89 bar)	≥ 1.00 in ³
D	0.052" DVP	65.01 l/min (137.7 scfh)	100 psig (6,89 bar)	≥ 2.00 in ³
F	0.035" DVP	32.0 l/min (67.8 scfh)	100 psig (6,89 bar)	≥ 1.00 in ³

Flow & Valve Selection Notes

- » Max flow assumes a P1 value of (at least) 10% above max pressure listed. Ex: a max pressure out of 50 psig assumes a min P1 value of 55 psig.
- » Min Critical Volume is the minimum required downstream volume for Cordis to provide stable, accurate and repeatable pressure control.
- » If the process leaks and/or dynamic conditions exist, there is no downstream volume requirement.

Accessories | Cables



<<CPCH-C1 Molded Actuation Cable, 8-Pin, 6'



<<CPCH-C2 3.3 VDC Serial Cable, 3'



<<CPCH-CA6 Power Cord, 6' (card unit only)

Ordering Information

EXAMPLE PART NUMBER | CPC-CFE-GA

CPC	-	C	F	E	-	G	A	
Make	-	Type	Porting	Command	-	Calibrated Pressure Range		Min. Volume/Flow @ Max. Pressure*
CPC		C Card Unit	F 1/8" NPT	E 0 to 10 VDC		A 0-1 psig	M 0 to 7 bar	A ≥0.25 in ³ / 2.7 l/min
		H Housed Unit	G G1/8	R Serial		B 0-5 psig	N 0 to 10 bar	B ≥0.50 in ³ / 6.7 l/min
			M Manifold	I 4 to 20 mA		C 0-15 psig	O 0 to 15 psia	C ≥1.00 in ³ / 25.0 l/min
						D 0-30 psig	P 0 to 30 psia	D ≥2.00 in ³ / 65.0 l/min
						E 0-60 psig	Q 0 to 100 psia	F ≥1.00 in ³ / 32.0 l/min
						F 0-100 psig	R -5 to +5 psid	
						G 0-150 psig	S -15 to +15 psid	
						H 0-0,1 bar	T 0 to 10" H2O	
						I 0-0,5 bar	U -10" to +10" H2O	
						J 0-1 bar	V 0 to 4" H2O	
						K 0-2 bar	W -1 to +1 psid	
						L 0-4 bar	Z Remote Sensor (consult Clippard)	

* All flow ranges are factory tested at 100 psig on the process side

Consult Clippard for availability of non-standard commands and other options

Table:11

Accessories | Mounting Bracket

Bracket for CPC-H Models only. Same bracket can be used for foot mounting or rear mounting. Complete with 2 screws.

Part No: CPCH-B1

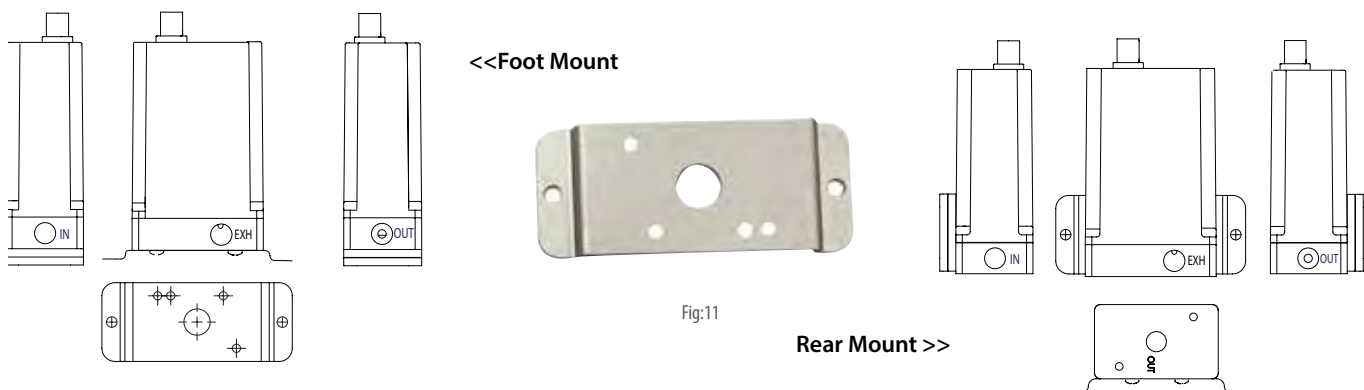

Bracket dimensions on page 19

Dimensions | CPC-C

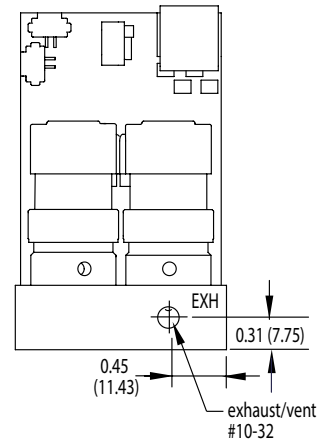
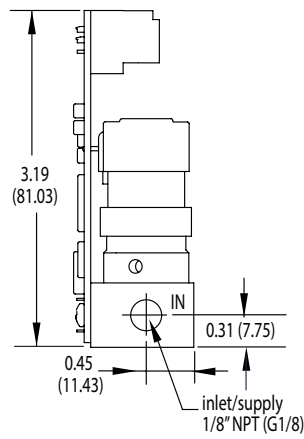
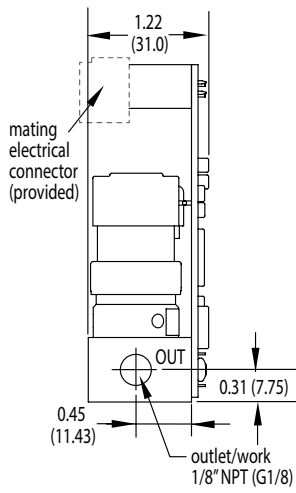
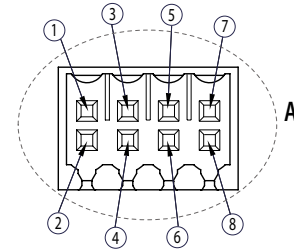
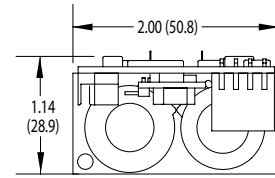
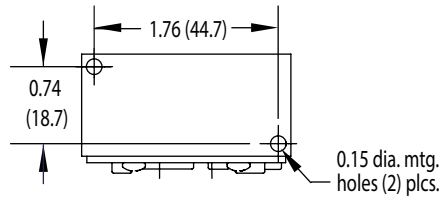

Dimensions | CPC-H

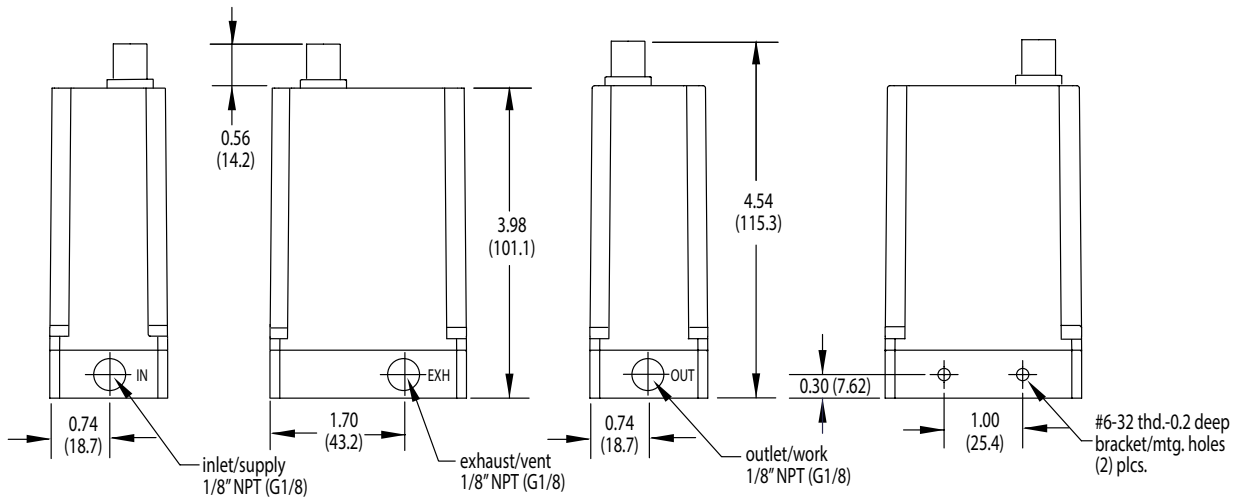
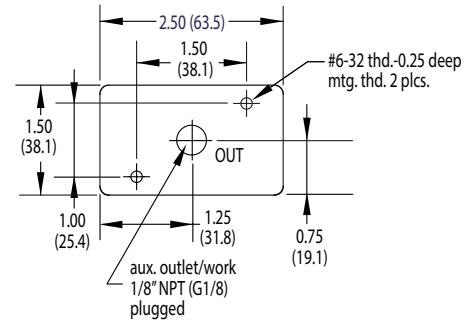
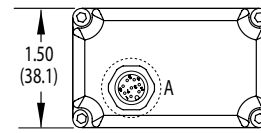
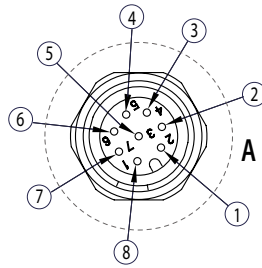

Mounting Bracket (optional)

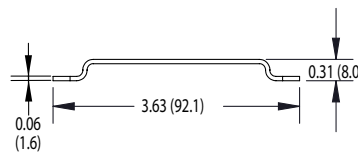
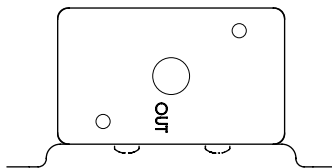



7390 Colerain Avenue
Cincinnati, OH 45239

1-513-521-4261
1-877-245-6247

Cordis, of the heart

Other Useful Materials

Digital vs. Analog Control White Paper

Pressure vs. Flow Control White Paper

Resolution in Proportional Control White Paper

View Frequently Asked Questions

View Web Site

Limited Warranty

All information contained in this publication is for reference only. Proper design engineering procedures should be used to assure any compliances. Clippard Instrument Laboratory, Inc. reserves the right to make changes without notice and does not warrant or guarantee the information contained herein.

Clippard Instrument Laboratory, Inc. (Seller) warrants its products to be free from defects in material and workmanship for a period of one (1) year from the date of sale. Seller's liability shall be limited at seller's option to repair, replace or refund purchase price of product found by seller's examination to be defective. All claims under this warranty must be made in writing to seller's factory sales department giving full details, prior to return of product, postpaid, to factory. Seller shall not be responsible for product failure due to normal wear, accident, buyer's misapplication, abuse, neglect or alteration of product. Seller will not be responsible for any consequential damages. Clippard makes no other warranty of any kind, expressed or implied. Circuits shown in this catalog are for instructional purposes only. All circuits used on equipment and machinery should be thoroughly tested by qualified personnel under actual working conditions to determine their suitability for buyer's intended use. All technical data and operations are average values based on standard production models. Some deviations can be expected and considerations should be given during initial design stages. All operating characteristics are based on new equipment, under normal conditions of use and environments and oil free air supply. Dimensions stated may be nominal and are subject to change without notice. Contact Clippard for specific dimensional tolerances when dimensions are critical.

Proudly made in the USA.

20 - CORDIS | 877-245-6247 | clippard.com | tech@clippard.com

CLIPPARD INSTRUMENT LABORATORY, INC. • ISO 9001 • INS-1.19 • V1.1