

SNAP 100 offers simple walk-up and measure capability. Simply place the part on the worktable and press GO. SNAP 100 includes

- **Automation Speeds Throughput** – SnapShot identifies and measures features instantly – without programming. Measured results are easily reported and exported.
- **Telecentric Optics** – Ensure accurate measurements across the wide field of view with low distortion – even when not perfectly focused. Zoom Anywhere technology instantly zooms the image anywhere in the wide field of view to measure small features instantly.
- **Simplicity and Value** – With its small footprint, the robust SNAP 100 uses three light sources, and a high-density metrology camera to make it the best choice for accurate measurements in the lab and on the shop floor.

Compact, Large Field of View Video Measuring Machine



Rugged construction and an open work envelope make SNAP easy to implement in virtually any manufacturing setting.

Measurements Made Simple

Choice of SNAP-X or ZONE3 Metrology Software

SNAP™ 100

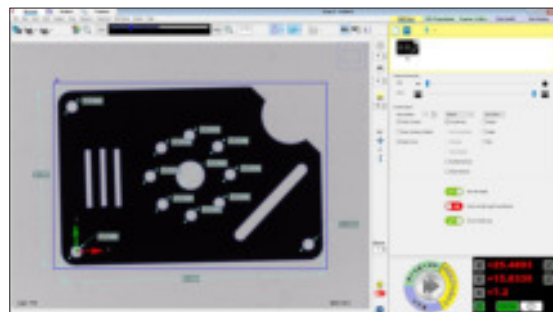

SNAP-X software provides users with a simple, powerful interface for instant 2D measurement and auto program generation. The software also utilizes powerful GD&T based algorithms and point and click feature identification to easily program a wide variety of parts. Virtual chart gaging, profile analysis tools and integrated reporting allow for quick and easy output of measurements.

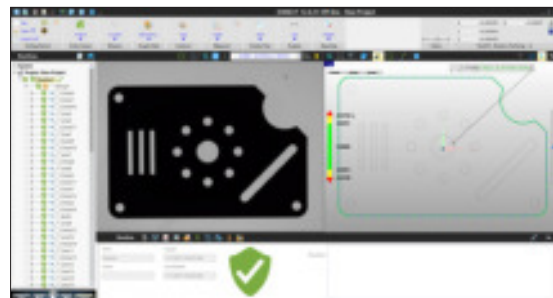

ZONE3 uses innovative features to automatically generate measurement routines resulting in faster programming and run times. Parallel Processing combined with intelligent routine optimization can be used to measure as many features as can be seen simultaneously.

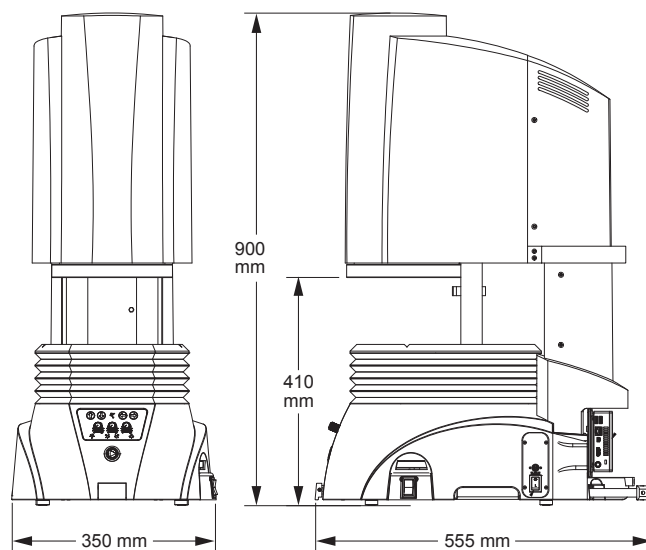

System Weight: 45 kg
Shipping Weight: 100 kg

	Standard	Optional
Measuring Unit	Rigid, cast aluminum base and nickel plated worktable; 4 kg load capacity, evenly distributed	
Stage	Motorized, programmable 75 mm Z axis (focus) adjustment with push-button controls	
Maximum Measuring Range (X,Y)	62 mm x 46 mm	
Optics	Telecentric, single optical magnification	
Illumination	All LED and monochromatic. Substage profile light, coaxial square-on surface light and programmable 8-sector oblique ring light	
Metrology Camera	High density megapixel metrology camera	
Field of View	62 mm x 46 mm	
Max Digital Zoom	15.5 mm x 11.5 mm	
Depth of Field	20 mm	
Working Distance	115 mm	
Controls	GO button, illumination controls, controls for motorized Z motion	
Software	Metrology Software: SNAP-X Measure and Compare	Metrology Software: ZONE3 Express, Prime, or Pro in lieu of SNAP-X Productivity Software: SNAP-X Analyze, OGP® EVOLVE® SPC Offline Software: SNAP-X or ZONE3
System Controller	Compact system controller with USB communication ports	Single flat panel LCD monitor, or dual flat panel LCD monitors; keyboard, mouse; USB-Ethernet adapter, system controller with networking and communication ports
Accessories		SNAP Miniature Rotary (SMR) indexer, barcode reader, USB digital I/O capability, fixture kit, calibration artifact
Power Requirements	100-120 VAC or 200-240 VAC, 50/60 Hz, 1 phase, 160 W	
Safe Operating Environment	15-30 °C, non-condensing	
Rated Environment	Temperature 18-22 °C, stable to ± 1 °C, max rate of change 1 °C / hour, max vertical gradient of 1 °C / meter; 30-80% humidity; vibration <0.001g below 15 Hz	
XY FOV Accuracy (E_y)	(4.0 + L/50) μm	

Accuracy is evaluated with a QVI verification procedure where "L" is measured length in millimeters. Specifications apply within the rated environment. Optical specifications apply at the maximum digital magnification of the specified configuration. XY FOV Accuracy applies with an evenly distributed load up to 2.5 kg in the standard measuring plane. The standard measuring plane is defined as perpendicular to the optical axis within 0.5 mm, and within 5.0 mm of best focus.



World Headquarters: Rochester, NY, USA • 585.544.0400 • www.ogpnet.com

OGP Shanghai Co, Ltd: Shanghai, China
86.21.5045.8383/8989 • www.smartscope.com.cn

OGP Messtechnik GmbH: Hofheim-Wallau, Germany
49.6122.9968.0 • www.ogpmesstechnik.de

Optical Gaging (S) Pte Ltd: Singapore • 65.6741.8880 • www.smartscope.com.sg