



OM Series Application Sheet

Company Type: **Manufacturing**
Market: **Industrial Agricultural Chemicals**
Application Category: **Monitoring**
Model Number: **OM008S513-222G6**

ADVANTAGES OF USING FLOMEC™ METERS

- COST SAVINGS
- ACCURACY
- SAFETY
- UPGRADE IN TECHNOLOGY

APPLICATION:

The OM Series meter monitors flowrate of fuel usage in two diesel powered boilers. The steam produced is used in the facility. The meter records totals and flowrate on the local display, and then transmits a 4-20mA signal to the PLC (Programmable Logic Controller), allowing for greater monitoring and control throughout the facility.

PROBLEM:

The customer needed to monitor the consumption rate of the generator from a remote location. Control of different systems within this facility was critical.

SOLUTION:

A pulse output to a PLC allowed for communication to the remote site. The upgrade in technology for this company provided better accuracy and control.

ILLUSTRATED APPLICATION:

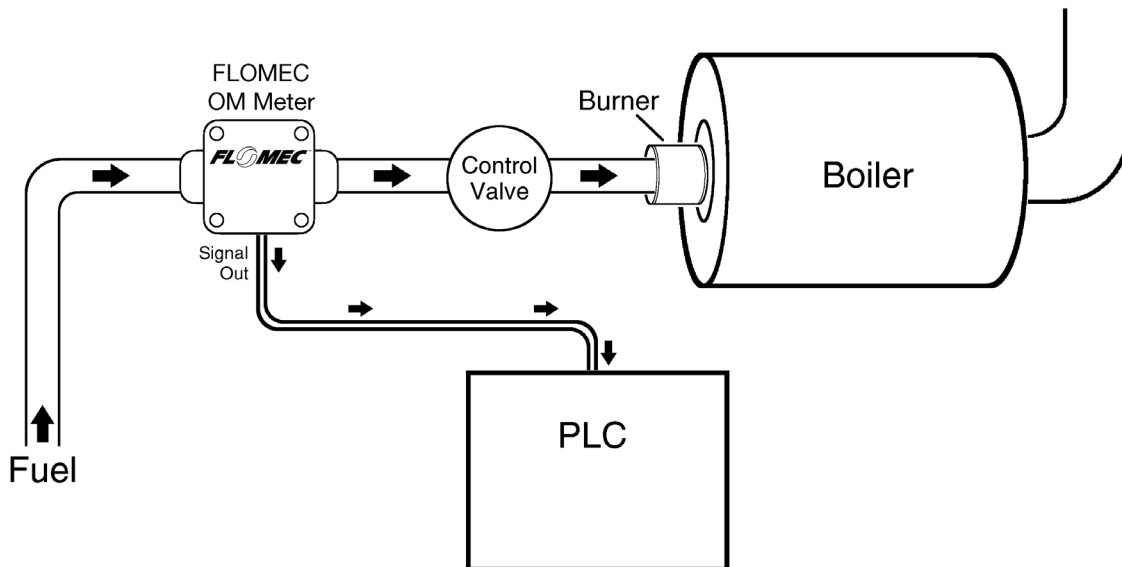

800.332.3418
Process Solutions Group
crossco.com | shopcross.com
fast.sales@crossco.com | fast.service@crossco.com