

HYDAC INTERNATIONAL

Compact Hydraulics

Cartridge Valves and Manifolds

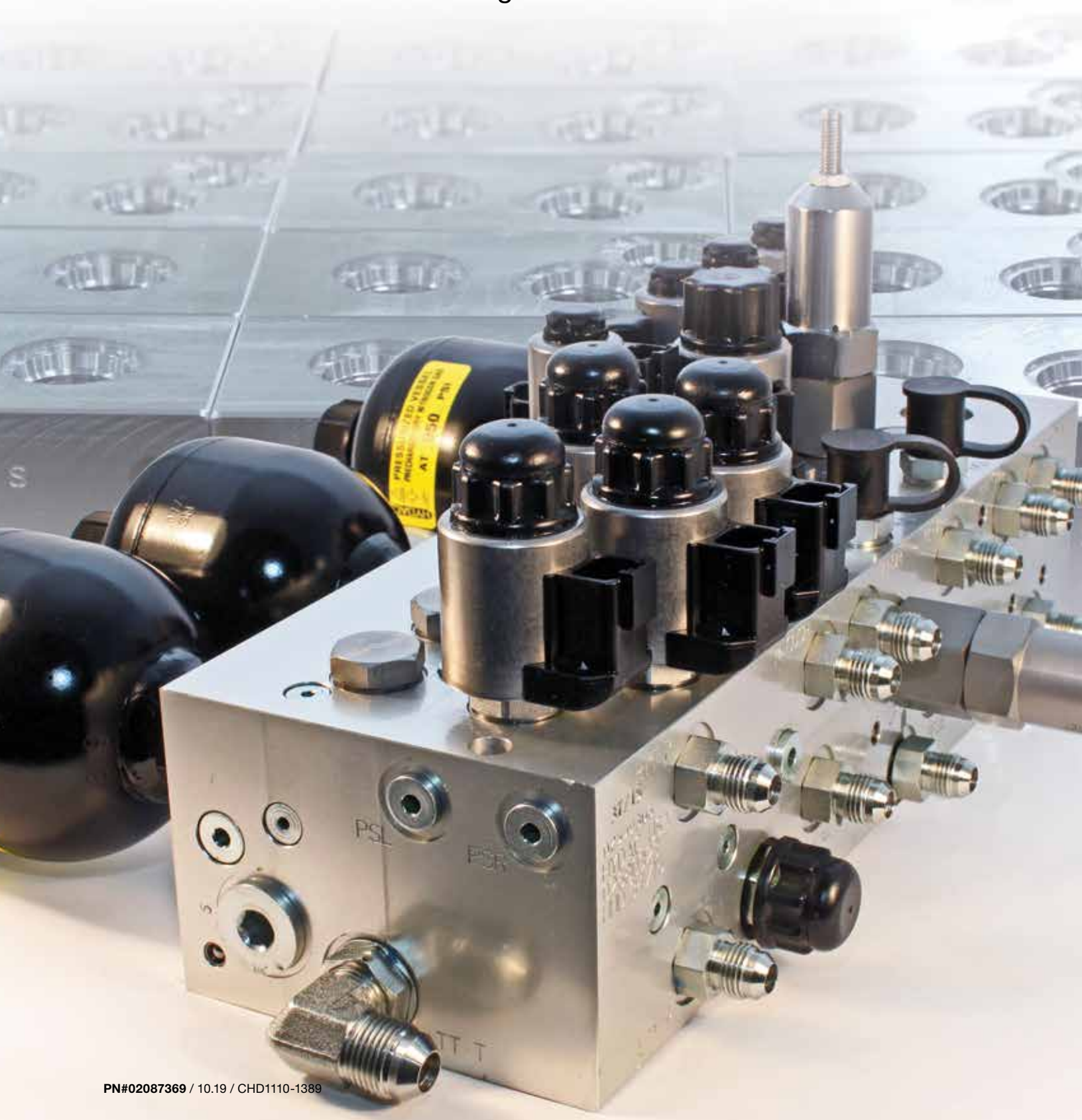



Components, Systems and Service. All from one Company.

Our fluid engineering solutions are defined by the scope and complexity of our customers' requirements.

Our products range from individually designed components in the fields of fluid engineering, hydraulics and electronics right up to complete systems for specific functions.

All components and systems are conceived and designed in-house. Experienced industrial and product specialists develop innovative products and efficient solutions for high-quality, cost-effective production. Throughout the globe, our production facilities share one common goal: quality. We take great pride in both our products and solutions.

Industries and Applications



Agriculture



Machine Tools



Fork Lifts



Construction Equipment



Utility Service Equipment



Wind Power



Forestry

TABLE OF CONTENTS

Section:

Overview of Cartridge Valves

Introduction - **A2**; Pressure Control Valves - **A3**; Flow Control Valves - **A3**; Check & Load Control Valves - **A4**; Pressure Sensing Valves - **A4**; Solenoid Valves - **A5**; Directional Control Valves - **A11**; Proportional Valves - **A11**; Pumps - **A11**; Integrated Manifolds - **A12**

A

Pressure Control Valves

Pressure Relief - **B2**; Pressure Reducing / Relieving - **B16**

B

Flow Control Valves

C

Check & Load Control Valves

Check Valves - **D2**; Counterbalance Valves - **D30**

D

Pressure Sensing Valves

E

Solenoid Valves

Poppet Type, Unidirectional, 2-position, 2-way - **F2**; Poppet Type, Bi-directional, 2-position, 2-way - **F50**;
Poppet Type, 2-position, 3-way - **F58**; Spool Type, 2-position, 2-way - **F60**; Spool Type, 2-position, 3-way - **F72**;
Spool Type, 2-position, 4-way - **F90**; Spool Type, 3-position, 4-way - **F122**

F

Directional Control Valves

G

Proportional Valves

Pressure Relief - **H2**; Pressure Reducing/Relieving - **H10**

H

Pumps

Manually Operated - **I2**

I

Solenoid Coils

Coils for Size 8, 10, 12 & 16 Cartridges - **J2**; Quick Reference - **J3**; Coil Type 40 Dimensions - **J7**; Coil Type 50 Dimensions - **J8**;
Coils for Size 6 Cartridges - **J9**; Coils Type 32 Dimensions - **J10**

J

Line Bodies & Cavities

Dimensions - **K4**; Cavity Drawings - **K6**

K

Manifold Accessories

Pilot Piston Assembly - **L2**; Cavity Plugs - **L5**

L

Miscellaneous Parts

Seal Kits - **M2**; Solenoid Valve Replacement Nuts - **M3**; Adjustment Kits - **M3**; Form Tools - **M4**; Quotation Request - **M5**

M



Cartridge Valves Division

450 Windy Point Drive
Glendale Heights, IL 60139
+1.630.545.0800
Internet: www.hydac-na.com
Email: CHD.catalog@hydac-na.com

NOTE

Information and related materials are subject to change without notice. This catalog, and all information and related materials it contains, are provided "as is." HYDAC makes no representation or warranty whatsoever regarding the completeness, accuracy, "up-to-dateness", or adequacy of, the HYDAC-NA domain and this catalog.

OVERVIEW

Complete Systems Solution for All Mobile Applications

HYDAC offers a choice of common UNF and metric cavities cartridge valves (this catalog details UNF products), rated up to 6000 psi to provide a wide variety of hydraulic functions:

Solenoid Directional Controls

- Poppet Valves, leakfree, rated up to 5000 psi
- Spool valves, high flow, rated up to 5000 psi
- Manual override options on all solenoid valves
- Environmentally rated coils for demanding applications

Pressure Controls

- Pressure Relief with up to 6000 psi pressure rating
- Pressure Reducing valves with consistent pressure control stability and precision

Flow Controls

- High accuracy Pressure Compensated flow regulators

Load Control Valves

- Flow Divider/Combiner valves
- Load Control Valves
- Check valves, rated up to 6000 psi
- Pilot Operated Check valves, rated up to 6000 psi
- Counterbalance Valves, rated up to 5000 psi

Proportional Control Valves

- Proportional Relief valves, rated up to 5000 psi
- Proportional Pressure Reducing valves, rated up to 5000 psi
- Proportional Flow Regulators

Standard Line Bodies

Common UNF Cavities in Steel and Aluminum

Integrated Manifolds

Used in applications where high performance and reliability are important.

HYDAC can satisfy customers' needs for **Complete Cost-Effective System Solutions** by incorporating cartridge valves and other HYDAC hydraulic components, such as Filters, Accumulators, and Accessories into Integrated Manifolds.

Common applications include:

- Construction Equipment
- Farm Machinery
- Utility Service Equipment
- Aerial Work Platforms
- Lift Trucks
- Refuse Management Equipment
- Road Maintenance Equipment

HYDAC's 50+ years of Cartridge Valves design and manufacturing experience and Global operations in more than 40+ countries provide excellent support for all your control systems and applications needs.

Approvals



Viton® is a registered trademark of Dupont.

Pressure Control Valves

Pressure Relief

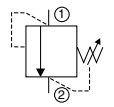
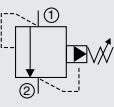
Symbol	Description	Model	Flow Rate		Pressure		Cavity	Page #
			gpm	l/min	psi	bar		
	Direct Acting, Ball Type	DB06A-01	4	15	5000	350	FC06-2	16
	Direct Acting, Poppet Type	DB06C-01	5	19	5000	350	FC06-2	18
		DB08A-01	10	38	6000	420	FC08-2	20
	Pilot Operated, Spool Type	DB08P-01	16	60	5000	350	FC08-2	22
		DB10P-01	32	120	6000	420	FC10-2	24
		DB12P-01	53	200	5000	350	FC12-2	26
		DB16P-01	79	300	5000	350	FC16-2	28

Pressure Reducing / Relieving

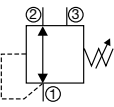
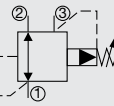

Symbol	Description	Model	Flow Rate		Pressure		Cavity	Page #
			gpm	l/min	psi	bar		
	Direct Acting, Spool Type	DR08-01	4	15	6000	420	FC08-3	30
		DR10-01	16	60	6000	420	FC10-3	32
	Pilot Operated, Spool Type	DR08P-01	16	60	5000	350	FC08-3	34
		DR10P-01	26	100	5000	420	FC10-3	36

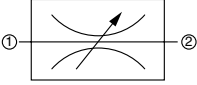
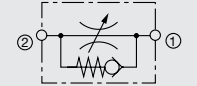
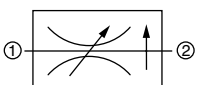
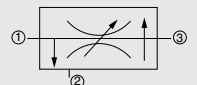
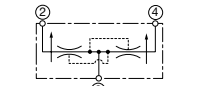
Flow Control Valves

Symbol	Description	Model	Flow Rate		Pressure		Cavity	Page #
			gpm	l/min	psi	bar		
	Needle Valve, Poppet Type	SD08-01	16	60	6000	420	FC08-2	40
		SD10-01	42	160	6000	420	FC08-2	42
	Needle Valve, Free Reverse Flow	SDR10A-01	42	160	5000	350	FC10-2	44
	Flow Regulator, Pressure Compensated, Restrictive Type	SR06-01	4	15	5000	350	FC06-2	46
		SR08-01	8	30	6000	420	FC08-2	48
		SR10-01	10	38	5000	350	FC10-2	50
	Flow Regulator, Pressure Compensated, Priority Type	SRP08-01	8	30	6000	420	FC08-3	52
	Flow Divider/Combiner, Re-synchronizing	ST10-01	12	45	5000	350	FC10-4	54
		ST16-01	39	150	5000	350	FC16-4	56

Check & Load Control Valves

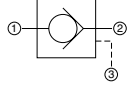

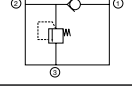
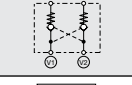
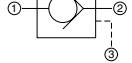

Check Valves

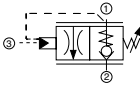
Symbol	Description	Model	Flow Rate		Pressure		Cavity	Page #
			gpm	l/min	psi	bar		
	Pilot-to-Open, Poppet Type	RP08A-01	10	38	6000	420	FC08-3	60
		RP10A-01	16	60	6000	420	FC10-3	62
		RP16A-01	40	150	6000	420	FC16-3	64
	Ball Type	RV06A-01	4	15	5000	350	FC06-2	66
		RV08A-01	10	38	6000	420	FC08-2	68
		RV10A-01	21	80	6000	420	FC10-2	70
	Poppet Type	RV12A-01	31	120	6000	420	FC12-2	72
		RV16A-01	44	165	6000	420	FC16-2	74
	Integral Relief, Ball Type	RV06B-01	4	15	5000	350	FC06-3	76
	Integral Relief, Poppet Type	RV06C-01	5	19	5000	350	FC06-3	78
	Dual Pilot-to-Open, Inline Body	RVD08A-01	10	38	6000	420	Inline	80
		RVD10A-01	21	80	6000	420	Inline	82
	Single Pilot-to-Open, Inline Body	RVS08A-01	10	38	5000	350	Inline	84
		RVS10A-01	21	80	6000	420	Inline	86

Counterbalance Valves

Symbol	Description	Model	Flow Rate		Pressure		Cavity	Page #
			gpm	l/min	psi	bar		
	Counterbalance Valve	RS08-01	10	38	5000	350	FC08-3	88

Pressure Sensing Valves

Symbol	Description	Model	Flow Rate		Pressure		Cavity	Page #
			gpm	l/min	psi	bar		
	Normally Closed, Vent to Open	DW10SA-01	40	151	5000	350	FC10-S3	92
		DW16SA-01	75	284	5000	350	FC16-S3	94
	Normally Open, Vented	DW10SC-01	8	30	5000	350	FC10-S3	96
		DW16SC-01	30	114	5000	350	FC16-S3	98
	Normally Open	DW10V-01	8	30	5000	350	FC10-S3	100
		DW16V-01	30	114	5000	350	FC16-S3	102
	Normally Closed	DW10Z-01	40	151	5000	350	FC10-S3	104
		DW16Z-01	80	304	5000	350	FC16-S3	106

Solenoid Valves

Poppet Type, Unidirectional, 2-position, 2-way

Symbol	Description	Model	Flow Rate		Pressure		Cavity	Page #
			gpm	l/min	psi	bar		
	Normally Open, Pilot Operated	WS06Y-01	3.5	13	5000	350	FC06-2	110
	Normally Open, Pilot Operated, Manual Override, Push Type	WS06Y-01M						
	Normally Open, Pilot Operated	WS08Y-01	10	38	5000	350	FC08-2	112
	Normally Open, Pilot Operated, Manual Override, Push Type	WS08Y-01M						
	Normally Open, Pilot Operated	WS10Y-01	20	75	5000	350	FC10-2	114
	Normally Open, Pilot Operated, Manual Override, Push Type	WS10Y-01M						
	Normally Open, Pilot Operated	WS12Y-01	29	110	5000	350	FC12-2	116
	Normally Open, Pilot Operated, Manual Override, Push Type	WS12Y-01M						
	Normally Open, Pilot Operated	WS16Y-01	40	150	5000	350	FC16-2	118
	Normally Open, Pilot Operated, Manual Override, Push Type	WS16Y-01M						
	Normally Open, Pilot Operated with Screen	WS08Y-30	8	30	5000	350	FC08-2	120
	Normally Open, Pilot Operated with Screen, Manual Override, Push Type	WS08Y-30M						
	Normally Open, Pilot Operated, Free Reverse Flow	WS08YR-01	10	38	5000	350	FC08-2	122
	Normally Open, Pilot Operated, Free Reverse Flow, Manual Override, Push Type	WS08YR-01M						
	Normally Open, Pilot Operated, Free Reverse Flow	WS10YR-01	20	75	5000	350	FC10-2	124
	Normally Open, Pilot Operated, Free Reverse Flow, Manual Override, Push Type	WS10YR-01M						
	Normally Open, Pilot Operated, Free Reverse Flow	WS12YR-01	29	110	5000	350	FC12-2	126
	Normally Open, Pilot Operated, Free Reverse Flow, Manual Override, Push Type	WS12YR-01M						
	Normally Open, Pilot Operated, Free Reverse Flow	WS16YR-01	40	150	5000	350	FC16-2	128
	Normally Open, Pilot Operated, Free Reverse Flow, Manual Override, Push Type	WS16YR-01M						
	Normally Open, Pilot Operated with Screen Free Reverse Flow	WS08YR-30	8	30	5000	350	FC08-2	130
	Normally Open, Pilot Operated with Screen Free Reverse Flow, Manual Override, Push Type	WS08YR-30M						

Solenoid Valves

Poppet Type, Unidirectional, 2-position, 2-way (cont.)

Symbol	Description	Model	Flow Rate		Pressure		Cavity	Page #
			gpm	l/min	psi	bar		
	Normally Closed, Pilot Operated	WS06Z-01	5	19	5000	350	FC06-2	132
	Normally Closed, Pilot Operated, Manual Override, Push Type	WS06Z-01M						
	Normally Closed, Pilot Operated	WS08Z-01	10	38	5000	350	FC08-2	134
	Normally Closed, Pilot Operated, Manual Override, Screw Type	WS08Z-01M						
	Normally Closed, Pilot Operated	WS10Z-01	20	75	5000	350	FC10-2	136
	Normally Closed, Pilot Operated, Manual Override, Screw Type	WS10Z-01M						
	Normally Closed, Pilot Operated	WS12Z-01	29	110	5000	350	FC12-2	138
	Normally Closed, Pilot Operated, Manual Override, Screw Type	WS12Z-01M						
	Normally Closed, Pilot Operated	WS16Z-01	40	150	5000	350	FC16-2	140
	Normally Closed, Pilot Operated, Manual Override, Screw Type	WS16Z-01M						
	Normally Closed, Pilot Operated, Manual Override, Pull Type, Spring Return	WS08Z-01J	10	38	5000	350	FC08-2	142
	Normally Closed, Pilot Operated with Screen	WS08Z-30	8	30	5000	350	FC08-2	144
	Normally Closed, Pilot Operated with Screen, Manual Override, Screw Type	WS08Z-30M						
	Normally Closed, Pilot Operated, Free Reverse Flow	WS08ZR-01	10	38	5000	350	FC08-2	146
	Normally Closed, Pilot Operated, Free Reverse Flow, Manual Override, Screw Type	WS08ZR-01M						
	Normally Closed, Pilot Operated, Free Reverse Flow	WS10ZR-01	20	75	5000	350	FC10-2	148
	Normally Closed, Pilot Operated, Free Reverse Flow, Manual Override, Screw Type	WS10ZR-01M						
	Normally Closed, Pilot Operated, Free Reverse Flow	WS12ZR-01	29	110	5000	350	FC12-2	150
	Normally Closed, Pilot Operated, Free Reverse Flow, Manual Override, Screw Type	WS12ZR-01M						
	Normally Closed, Pilot Operated, Free Reverse Flow	WS16ZR-01	40	150	5000	350	FC16-2	152
	Normally Closed, Pilot Operated, Free Reverse Flow, Manual Override, Screw Type	WS16ZR-01M						
	Normally Closed, Pilot Operated, Free Reverse Flow, Manual Override, Pull Type, Spring Return	WS08ZR-01J	10	38	5000	350	FC08-2	154
	Normally Closed, Pilot Operated with Screen, Free Reverse Flow	WS08ZR-30	8	30	5000	350	FC08-2	156
	Normally Closed, Pilot Operated with Screen, Free Reverse Flow, Manual Override, Screw Type	WS08ZR-30M						

Solenoid Valves

Poppet Type, Bi-directional, 2-position, 2-way

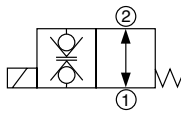
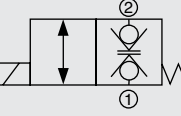
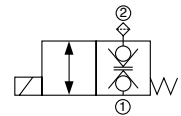
Symbol	Description	Model	Flow Rate		Pressure		Cavity	Page #
			gpm	l/min	psi	bar		
	Normally Open, Direct Acting	WS08V-01	5	19	5000	350	FC08-2	158
	Normally Open, Direct Acting, Manual Override, Push Type	WS08V-01M						
	Normally Closed, Direct Acting	WS08W-01	5	19	3600	250	FC08-2	160
	Normally Closed, Direct Acting, Manual Override, Push Type	WS08W-01M						
	Normally Closed, Direct Acting	WS10W-01	10.5	40	5000	350	FC10-2	162
	Normally Closed, Direct Acting, Manual Override, Push Type	WS10W-01M						
	Normally Closed, Direct Acting with Screen	WS08W-30	5	19	3600	250	FC08-2	164
	Normally Closed, Direct Acting with Screen, Manual Override, Push Type	WS08W-30M						

Poppet Type, 2-position, 3-way

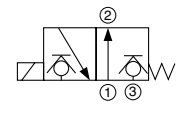
Symbol	Description	Model	Flow Rate		Pressure		Cavity	Page #
			gpm	l/min	psi	bar		
	Normally Closed, Direct Acting	WS08D-51	5	19	4000	280	FC08-3	166
	Normally Closed, Direct Acting, Manual Override, Push Type	WS08D-51M						

Solenoid Valves

Spool Type, 2-position, 2-way

Symbol	Description	Model	Flow Rate		Pressure		Cavity	Page #
			gpm	l/min	psi	bar		
	Normally Open, Direct Acting	WK06V-01	4	15.2	5000	350	FC06-2	168
	Normally Open, Direct Acting, Manual Override Push Type	WK06V-01M						
	Normally Open, Direct Acting	WK08V-01	5	19	5000	350	FC08-2	170
	Normally Open, Direct Acting, Manual Override Push Type	WK08V-01M						
	Normally Open, Direct Acting	WK10V-01	9	35	5000	350	FC10-2	172
	Normally Open, Direct Acting, Manual Override, Push Type	WK10V-01M						
	Normally Closed, Direct Acting	WK06W-01	2.5	9.5	5000	350	FC06-2	174
	Normally Closed, Direct Acting Manual Override, Push Type	WK06W-01M						
	Normally Closed, Direct Acting	WK08W-01	5	19	5000	350	FC08-2	176
	Normally Closed, Direct Acting, Manual Override, Screw Type	WK08W-01M						
	Normally Closed, Direct Acting	WK10W-01	9	35	5000	350	FC10-2	178
	Normally Closed, Direct Acting, Manual Override, Screw Type	WK10W-01M						

Spool Type, 2-position, 3-way

Symbol	Description	Model	Flow Rate		Pressure		Cavity	Page #
			gpm	l/min	psi	bar		
	Direct Acting	WK06C-01	4	15	5000	350	FC06-3	180
	Direct Acting, Manual Override, Push Type	WK06C-01M						
	Direct Acting	WK08C-01	5	19	5000	350	FC08-3	182
	Direct Acting, Manual Override, Push Type	WK08C-01M						
	Direct Acting	WK10C-01	8.4	32	5000	350	FC10-3	184
	Direct Acting, Manual Override, Push Type	WK10C-01M						
	Direct Acting	WK10C-40	8.4	32	5000	350	FC10-3	186
	Direct Acting, Manual Override, Push Type	WK10C-40M						
	Direct Acting	WK08D-01	5	19	5000	350	FC08-3	188
	Direct Acting, Manual Override, Push Type	WK08D-01M						
	Direct Acting	WK10D-01	8.4	32	5000	350	FC10-3	190
	Direct Acting, Manual Override, Screw Type	WK10D-01M						
	Direct Acting	WK07L-01	2.5	10	5000	350	FC07-3	192
	Direct Acting, Manual Override, Screw Type	WK07L-01M						
	Direct Acting	WK08L-01	5	19	5000	350	FC08-3	194
	Direct Acting, Manual Override, Push Type	WK08L-01M						
	Direct Acting	WK10L-01	8.4	32	5000	350	FC10-3	196
	Direct Acting, Manual Override, Push Type	WK10L-01M						

Solenoid Valves

Spool Type, 2-position, 4-way

Symbol	Description	Model	Flow Rate		Pressure		Cavity	Page #
			gpm	l/min	psi	bar		
	Direct Acting	WK08A-01	5	19	5000	350	FC08-4	198
	Direct Acting, Manual Override, Push Type	WK08A-01M						
	Direct Acting	WK10A-01	8.4	32	5000	350	FC10-4	200
	Direct Acting, Manual Override, Push Type	WK10A-01M						
	Direct Acting	WK08K-01	4	15	5000	350	FC08-4	202
	Direct Acting, Manual Override, Push Type	WK08K-01M						
	Direct Acting	WK10K-01	8.4	32	5000	350	FC10-4	204
	Direct Acting, Manual Override, Screw Type	WK10K-01M						
	Direct Acting	WK10N-01	8.4	32	5000	350	FC10-4	206
	Direct Acting, Manual Override, Push Type	WK10N-01M						
	Direct Acting	WK08P-01	4	15	5000	350	FC08-4	208
	Direct Acting, Manual Override, Screw Type	WK08P-01M						
	Direct Acting	WK10P-01	8.4	32	5000	350	FC10-4	210
	Direct Acting, Manual Override, Screw Type	WK10P-01M						
	Direct Acting	WK08R-01	5	19	5000	350	FC08-4	212
	Direct Acting, Manual Override, Push Type	WK08R-01M						
	Direct Acting	WK10R-01	8.4	32	5000	350	FC10-4	214
	Direct Acting, Manual Override, Push Type	WK10R-01M						
	Direct Acting	WK08X-01	4.5	17	5000	350	FC08-4	216
	Direct Acting, Manual Override, Screw Type	WK08X-01M						
	Direct Acting	WK10X-01	8.4	32	5000	350	FC10-4	218
	Direct Acting, Manual Override, Screw Type	WK10X-01M						
	Direct Acting	WK06Y-01	2	7.6	5000	350	FC06-4	220
	Direct Acting, Manual Override, Push Type	WK06Y-01M						
	Direct Acting	WK08Y-01	5	19	5000	350	FC08-4	222
	Direct Acting, Manual Override, Push Type	WK08Y-01M						
	Direct Acting	WK10Y-01	8.4	32	5000	350	FC10-4	224
	Direct Acting, Manual Override, Push Type	WK10Y-01M						
	Direct Acting	WK08Z-01	4.5	17	5000	350	FC08-4	226
	Direct Acting, Manual Override, Push Type	WK08Z-01M						
	Direct Acting	WK10Z-01	8.4	32	5000	350	FC10-4	228
	Direct Acting, Manual Override, Screw Type	WK10Z-01M						

Solenoid Valves

Spool Type, 3-position, 4-way

Symbol	Description	Model	Flow Rate		Pressure		Cavity	Page #
			gpm	l/min	psi	bar		
	Direct Acting	WK06E-01	3	11.4	5000	350	FC06-4	230
	Direct Acting, Manual Override	WK06E-01M						
	Direct Acting	WK08E-01	5	19	5000	350	FC08-4	232
	Direct Acting, Manual Override, Push/Pull Type, Non-Detented	WK08E-01M						
	Direct Acting, Manual Override, Push/Pull Type, Detented	WK08E-01A						
	Direct Acting	WK10E-01	6	23	5000	350	FC10-4	234
	Direct Acting, Manual Override, Push/Pull Type, Non-Detented	WK10E-01M						
	Direct Acting, Manual Override, Push/Pull Type, Detented	WK10E-01A						
	Direct Acting	WK06G-01	2	7.6	5000	350	FC06-4	236
	Direct Acting, Manual Override	WK06G-01M						
	Direct Acting	WK10G-01	6	23	5000	350	FC10-4	238
	Direct Acting, Manual Override, Push/Pull Type, Non-Detented	WK10G-01M						
	Direct Acting, Manual Override, Push/Pull Type, Detented	WK10G-01A						
	Direct Acting	WK06H-01	2.4	9	5000	350	FC06-4	240
	Direct Acting, Manual Override	WK06H-01M						
	Direct Acting	WK10H-01	6	23	5000	350	FC10-4	242
	Direct Acting, Manual Override, Push/Pull Type, Non-Detented	WK10H-01M						
	Direct Acting, Manual Override, Push/Pull Type, Detented	WK10H-01A						
	Direct Acting	WK06J-01	3	11.4	5000	350	FC06-4	244
	Direct Acting, Manual Override	WK06J-01M						
	Direct Acting	WK08J-01	5	19	5000	350	FC08-4	246
	Direct Acting, Manual Override, Push/Pull Type, Non-Detented	WK08J-01M						
	Direct Acting, Manual Override, Push/Pull Type, Detented	WK08J-01A						
	Direct Acting	WK10J-01	6	23	5000	350	FC10-4	248
	Direct Acting, Manual Override, Push/Pull Type, Non-Detented	WK10J-01M						
	Direct Acting, Manual Override, Push/Pull Type, Detented	WK10J-01A						
	Direct Acting	WK10T-01	6	23	5000	350	FC10-4	250
	Direct Acting, Manual Override, Push/Pull Type, Non-Detented	WK10T-01M						
	Direct Acting, Manual Override, Push/Pull Type, Detented	WK10T-01A						

Directional Control Valves

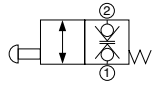
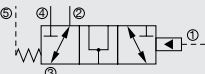
Symbol	Description	Model	Flow Rate		Pressure		Cavity	Page #
			gpm	l/min	psi	bar		
	Poppet Bi-Directional, Push to Operate, Manually Operated	WS08WM-01	5	20	3600	250	FC08-2	254
	Piloted 3-Way Spool, Hydraulically Operated	HPM45SE-01	70	265	5000	350	FCM45-5	256

Proportional Valves

Pressure Relief

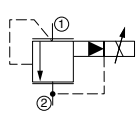
Symbol	Description	Model	Flow Rate		Pressure		Cavity	Page #
			gpm	l/min	psi	bar		
	Pilot Operated, Spool Type	PDB08P-01	16	60	5000	350	FC08-2	260
	Pilot Operated, Spool Type	PDB10P-01	31	120	5000	350	FC10-2	262
	Pilot Operated, Spool Type	PDB12P-01	53	200	5000	350	FC12-2	264
	Pilot Operated, Spool Type	PDB16P-01	79	300	5000	350	FC16-2	266

Pressure Reducing / Relieving

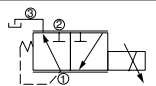
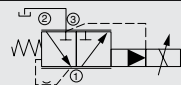
Symbol	Description	Model	Flow Rate		Pressure		Cavity	Page #
			gpm	l/min	psi	bar		
	Direct Acting, Spool Type	PDR08-01	3	12	5000	350	FC08-3	268
	Pilot Operated, Spool Type	PDR08P-01	16	60	5000	350	FC08-3	270
		PDR10P-01	21	80	5000	350	FC10-3	272

Pumps

Manually Operated

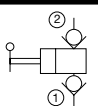
Symbol	Description	Model	Displacement per Stroke		Output Max Pressure		Cavity	Page #
			in	cm	psi	bar		
	Hand Pump, Free Pivot Handle	MP10-01	0.5	8.2	3000	207	FC10-2	276
	Hand Pump, Flange Mount	MP10-02						278

OVERVIEW

Integrated Manifolds

Cost Effective Solutions for Mobile and Industrial Applications



- Simplifies system procurement processing and reduces acquisition costs.
- Consolidates hydraulic control system into compact and neat assembly, saving space and weight
- Aluminum, steel or ductile iron manifold blocks
- 100% function testing
- Reduced installation time and system maintenance
- Minimizes external connections
- Reduces external leakage

Combining multiple cartridge valves and other hydraulic components in Integrated Manifolds offer both mobile and industrial customers' substantial advantages:



- Incorporating cartridge valves and other HYDAC's hydraulic components into Integrated manifolds provides a single source and simplifies system procurement processing, thus reducing acquisition cost.
- Complete system manifolds provide for compact and neat assembly, saving space and weight. They are designed to meet the performance and installation needs of the specific machine. By eliminating hoses, tubes and fittings necessary when traditional hydraulic valves are used, manifold systems dramatically reduce installation costs and system maintenance.
- Complete control system in a single manifold reduces potential for external leakage to ensure a cleaner and safer application environment.
- All aluminum manifolds are anodized for cleanliness, added surface hardening, and corrosion resistance. Ductile iron or steel manifolds are zinc plated on customer's requirements.
- A customer/product specific assembly drawing is prepared for every manifold.
- Every manifold is hydraulic function tested to a specific test procedure.
- HYDAC will assemble customer specified fittings or other components on request where feasible.



Size and Weight Saving Alternatives for Integrated Manifolds

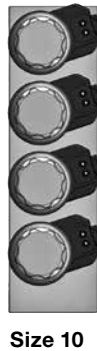
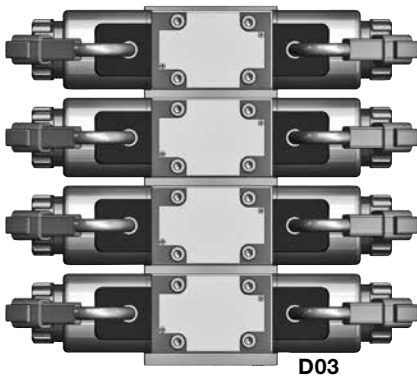
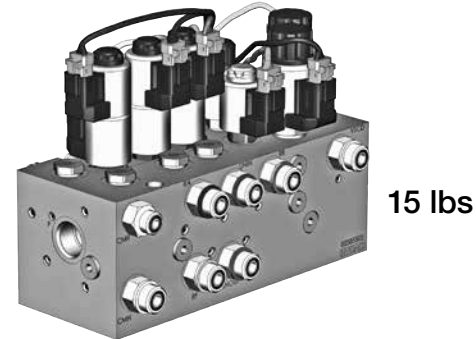
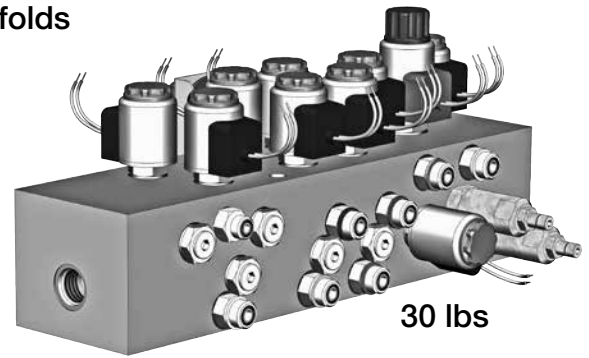
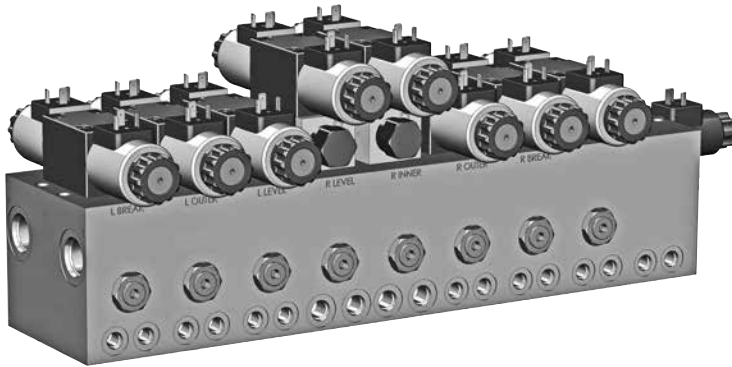

Weight Saving Example	
Size 06	100%
Size 08	160%
Size 10	200%
D03	400%

HYDAC provides support services for manifold makers

Application and Design Assistance

- To machine builders
- Local integrated circuit designers

2D and 3D Cartridge Valves Library

- Library includes cartridges and coils to facilitate manifold design and service documentation.
- DXF and DWG formats available
- CD available on request

Manifold Accessory Hardware

- We provide our customers with a variety of hardware commonly used in custom integrated manifolds, such as SAE plugs, cavity plugs, orifice plugs, pilot pistons.

Cavity Forming Tools

- Roughing tools are made of high-speed steel
- Finishing tools have carbide tips and are suitable for production of aluminum and steel blocks.

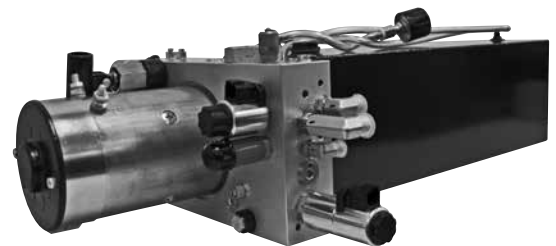

Actual Manifold Assemblies

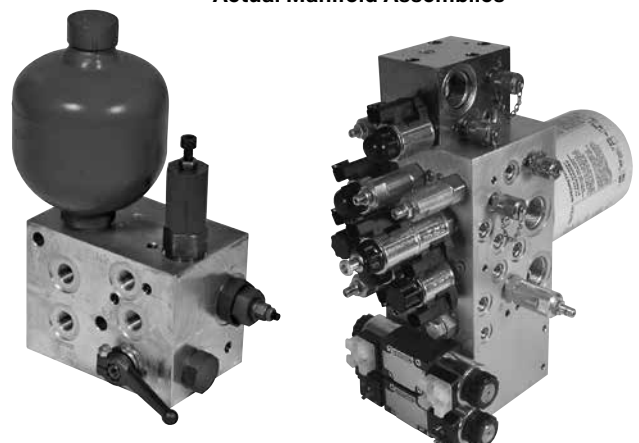

OVERVIEW

Notes

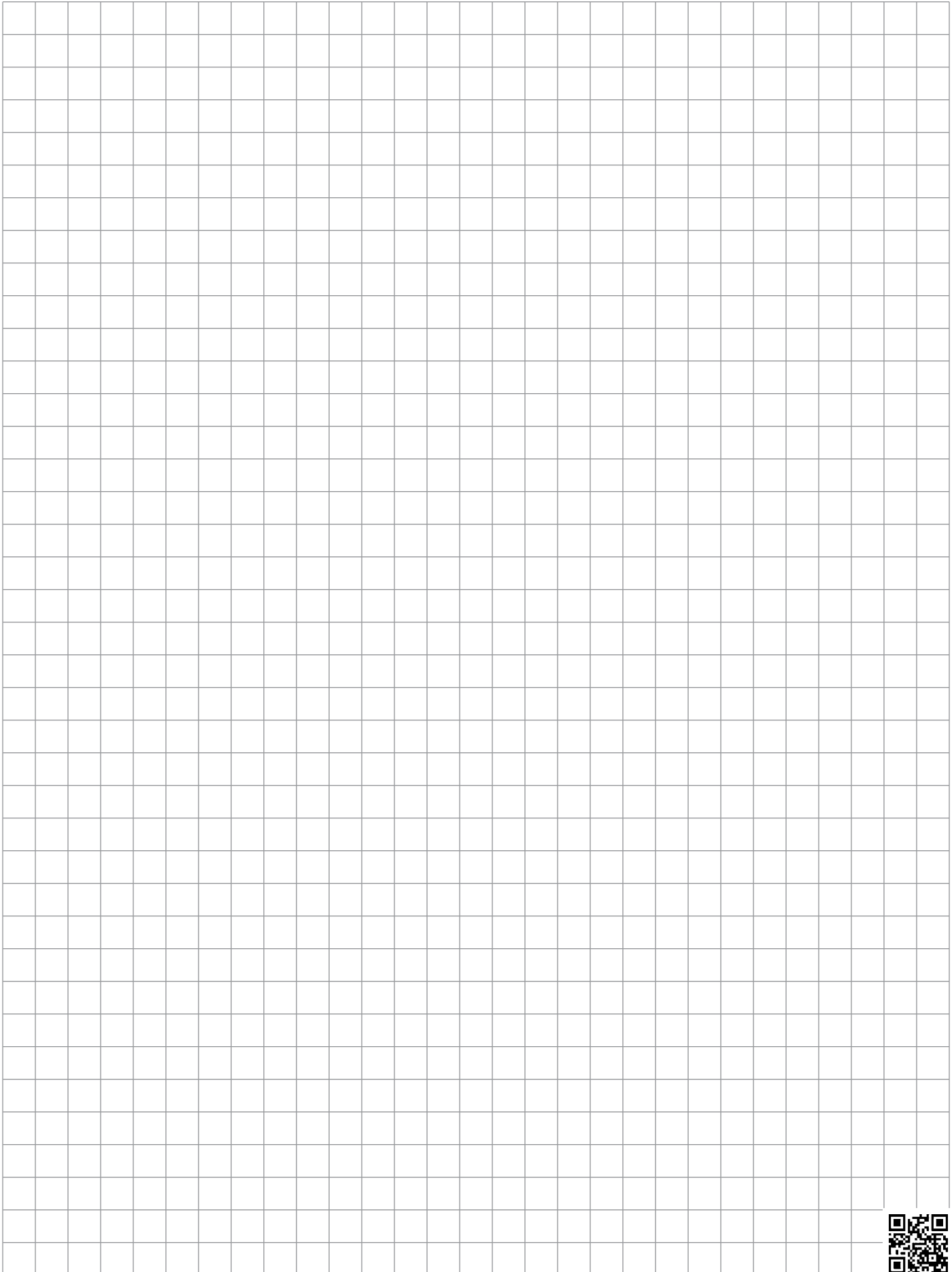

B1 Overview of Pressure Control Valves

HYDAC offers a wide range of direct acting and pilot operated Relief and Reducing Valves. In general, the direct acting valves are faster in response while pilot operated valves have flatter pressure/flow characteristics.

HYDAC Relief Valves are available in direct acting poppet and pilot operated spool types with optional pressure adjustment ranges up to 6000 psi (420 bar). Models are available for flow rates up to 80 gpm (300 l/min).

HYDAC Pressure Reducing Valves are direct acting and pilot operated spool types with optional pressure adjustment ranges up to 5000 psi (350 bar). They have been designed to maintain a constant secondary regulated pressure regardless of pressure variation in the primary system and have an additional relieving feature for the secondary circuit protection. Models are available for flow rates up to 26 gpm (100 l/min).

Features

- Adjustable under full pressure
- Stroke limiting device for enhanced safety
- Positive stop to prevent spring from over adjustment
- Screens to protect pilot orifice from contamination and ensure reliable operation
- Variety of adjustment mechanism options
- Fast response with excellent stability
- All external surfaces zinc-plated
- Hardened poppets or spools ensure minimal wear and extend service life
- One piece body maximizes reliability and minimizes the effects of eccentricity
- Industry common cavity-compact size



PRESSURE CONTROL VALVES

DB06A-01

Pressure Relief, Direct Acting, Ball Type

Up to 4 gpm (15 l/min) • 5000 psi (350 bar)

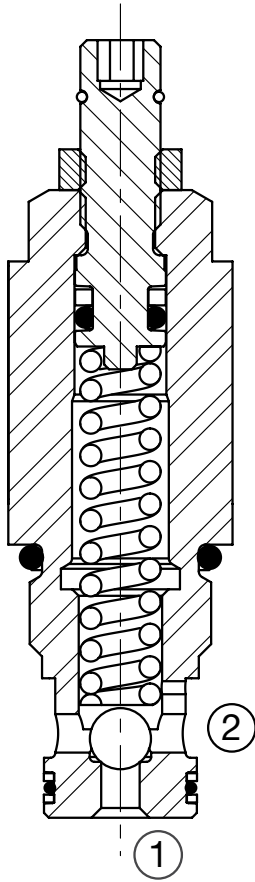
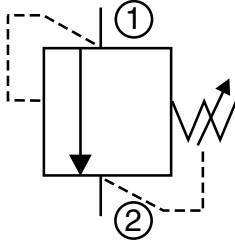

Description

A screw-in cartridge, direct acting, ball type relief valve intended for use as pressure limiting device in hydraulic circuits requiring low internal leakage and fast response.

Operation

The DB06A blocks flow from 1 to 2 until the predetermined pressure setting is reached at port 1 to lift the spring opposed ball from its seat, allowing flow from port 1 to port 2. Pressure at port 2 is directly additive to valve pressure setting. Flow from port 2 to port 1 is checked.

Features

- Spring ranges up to 5000 psi (350 bar)
- Positive stop prevents spring from over adjustment
- Adjustment screw cannot be backed out of the valve
- Adjustable under full pressure
- Fast response
- All external surfaces zinc-plated
- Hardened ball to ensure minimal wear and extend service life

Specifications

Operating Pressure	5000 psi (350 bar)
Maximum Flow Rate	4 gpm (15 l/min)
Internal Leakage	5 drops/min maximum to 75% of nominal setting
Optional Pressure Ranges	0 to 3000 psi (0 to 207 bar) 0 to 5000 psi (0 to 350 bar)
Reseat Pressure (Nominal)	80% of crack pressure
Fluid Operating Temp Range	-20° to 248°F (-29° to 120°C)
Fluid Compatibility	Mineral-Based or Synthetics with lubricating properties
Viscosity	50 to 2000 SUS (7.4 to 420 cSt)
Filtration	21/19/16 or cleaner per (ISO 4406)
Installation	No orientation restrictions
Cavity	FC06-2 (see <i>Line Bodies & Cavities</i> section)
Cavity Tools	Rougher: 02582046 Finisher: 02582047
Cartridge Weight	0.15 lb (68 g)
Cartridge Material	Steel with hardened work surfaces. Zinc plated exposed surfaces. Buna N or Viton® o-rings. Solid Thermoplastic Polyester back-up rings.
Seal Kits	Buna-N P/N: 02610184 Viton® P/N: 02610185

Performance

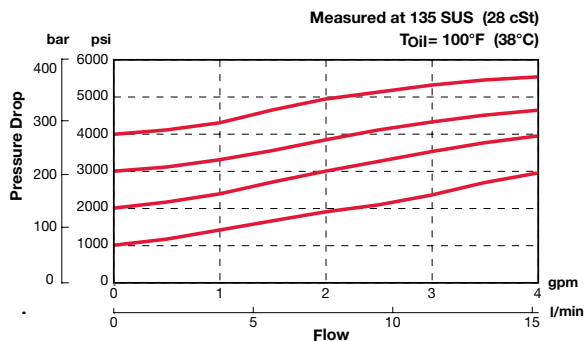

PRESSURE CONTROL VALVES

Dimensions

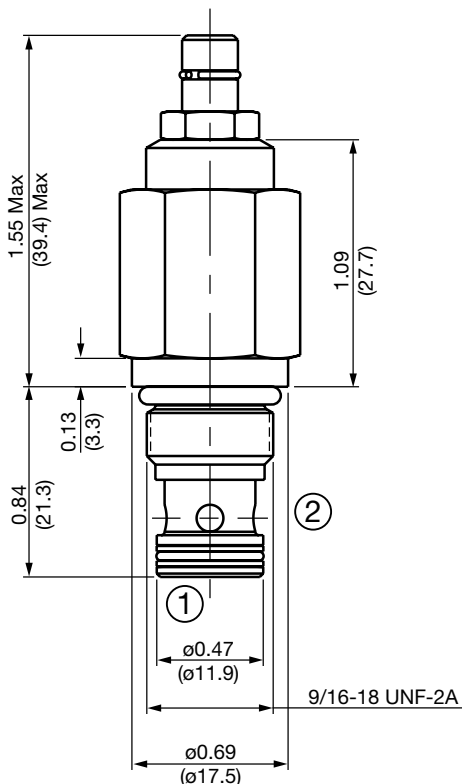
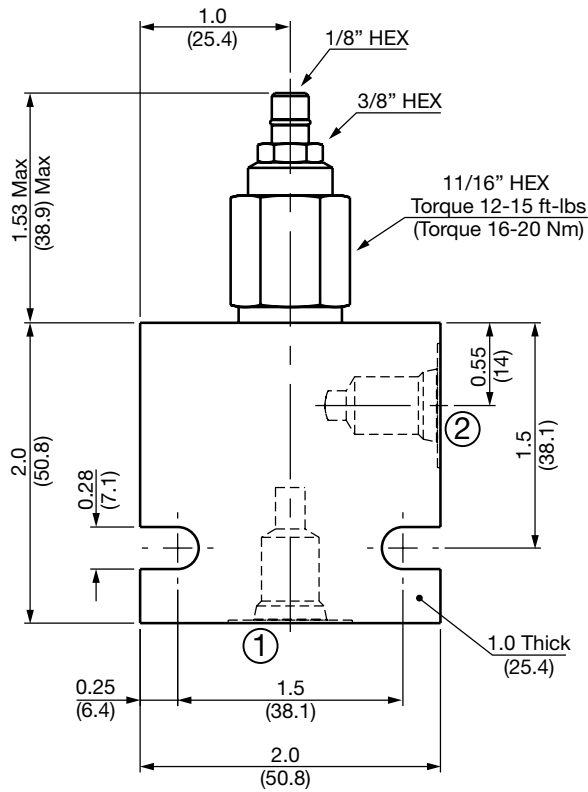

All measurements in inches (mm).
Subject to technical modifications

Model Code

DB06A-01-AS4-N-300 V 100

Valve Model	_____
Body & Ports	_____
C	= Cartridge only
AS4	= SAE-4 Ports, aluminum Body
SS4	= SAE-4 Ports, steel Body
Seals	_____
N	= Buna-N
V	= Viton®
Adjustment Range	_____
180	= 0 to 1800 psi (0 to 124 bar)
300	= 0 to 3000 psi (0 to 207 bar)
500	= 0 to 5000 psi (0 to 350 bar)
Adjustment Options	_____
V	= Allen Head (Hex 1/8")
Setting	_____
blank	= Set at 50% maximum pressure for the range
XXX	= Desired psi ÷ 10
<i>Example: 100 = 1000 psi</i>	

Standard Line Bodies*

Code	Part No	Material	Pressure Rating	Weight
FH062-AS4	02600491	Aluminum, anodized	3500 psi (245 bar)	0.34 lbs (0.15 kg)
FH062-SS4	02600490	Steel, Zinc plated	6000 psi (420 bar)	1.0 lbs (0.45 kg)

*Please refer to Line Bodies & Cavities section for details

PRESSURE CONTROL VALVES

DB06C-01

Pressure Relief, Direct Acting, Poppet Type

Up to 5 gpm (19 l/min) • 5000 psi (350 bar)

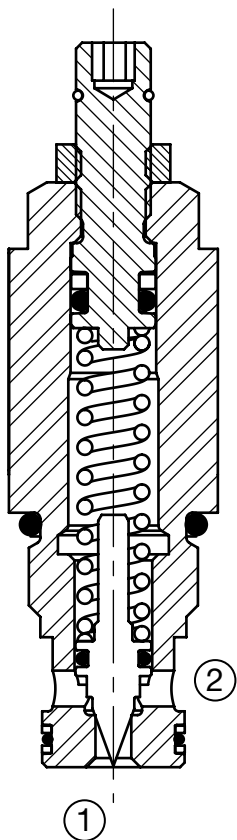
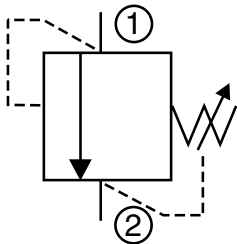

Description

A screw-in cartridge, direct acting, poppet type relief valve intended for use as pressure limiting device in hydraulic circuits requiring low internal leakage and fast response.

Operation

The DB06C blocks flow from 1 to 2 until the predetermined pressure setting is reached at port 1 to lift the spring opposed poppet from its seat, allowing flow from port 1 to port 2. Pressure at port 2 is directly additive to valve pressure setting. Flow from port 2 to port 1 is checked.

Features

- Spring ranges up to 5000 psi (350 bar)
- Positive stop prevents spring from over adjustment
- Adjustment screw cannot be backed out of the valve
- Adjustable under full pressure
- Fast response
- All external surfaces zinc-plated
- Hardened poppet to ensure minimal wear and extend service life

Specifications

Operating Pressure	5000 psi (350 bar)
Maximum Flow Rate	5 gpm (19 l/min)
Internal Leakage	5 drops/min maximum to 75% of nominal setting
Optional Pressure Ranges	0 to 1800 psi (0 to 124 bar) 0 to 3000 psi (0 to 207 bar) 1500 to 5000 psi (103 to 350 bar)
Reseat Pressure (Nominal)	80% of crack pressure
Fluid Operating Temp Range	-20° to 248°F (-29° to 120°C)
Fluid Compatibility	Mineral-Based or Synthetics with lubricating properties
Viscosity	50 to 2000 SUS (7.4 to 420 cSt)
Filtration	21/19/16 or cleaner per (ISO 4406)
Installation	No orientation restrictions
Cavity	FC06-2 (see <i>Line Bodies & Cavities</i> section)
Cavity Tools	Rougher: 02582046 Finisher: 02582047
Cartridge Weight	0.15 lb (68 g)
Cartridge Material	Steel with hardened work surfaces. Zinc plated exposed surfaces. Buna N or Viton® o-rings. Solid Thermoplastic Polyester back-up rings.
Seal Kits	Buna-N P/N: 02610184 Viton® P/N: 02610185

Performance

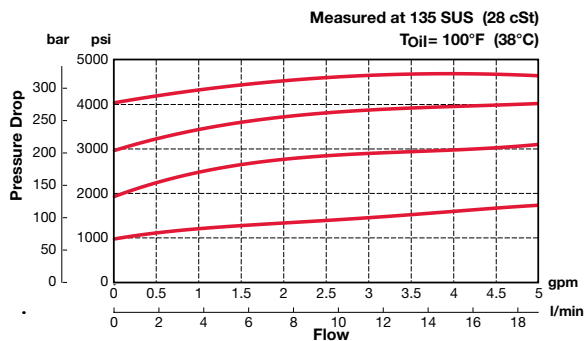

PRESSURE CONTROL VALVES

Dimensions

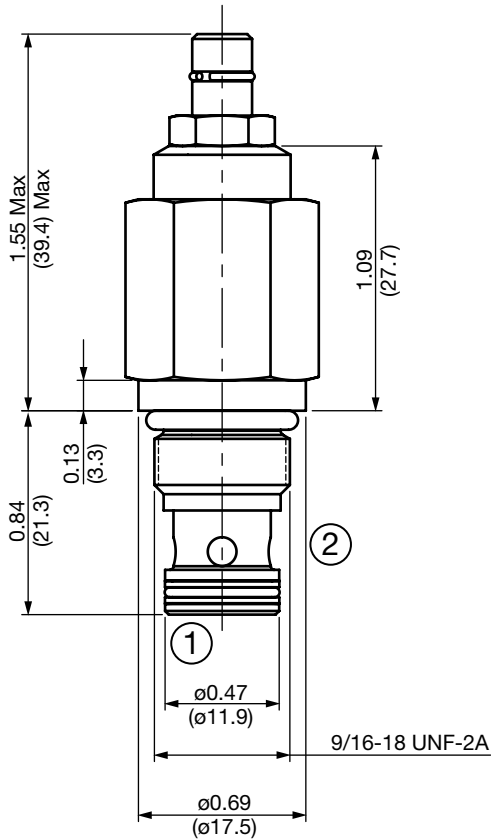
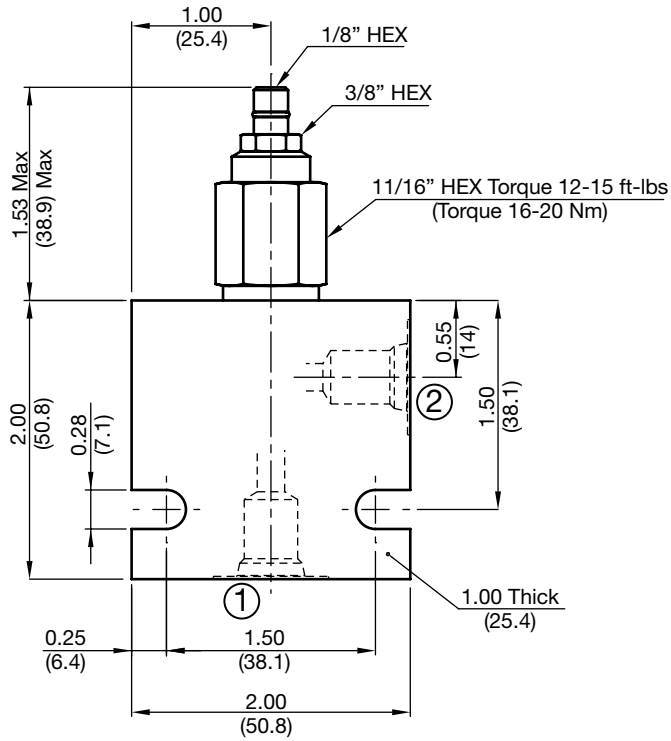

All measurements in inches (mm).
Subject to technical modifications

Model Code

DB06C-01-AS4-N-180 V 100

Valve Model	DB06C-01-AS4-N-180 V 100
Body & Ports	AS4 = SAE-4 Ports, aluminum Body SS4 = SAE-4 Ports, steel Body
Seals	N = Buna-N V = Viton®
Adjustment Range	180 = 0 to 1800 psi (0 to 124 bar) 300 = 0 to 3000 psi (0 to 207 bar) 500 = 1500 to 5000 psi (103 to 350 bar)
Adjustment Options	V = Allen Head (Hex 1/8")
Setting	blank = Set at 50% maximum pressure for the range XXX = Desired psi ÷ 10 Example: 100 = 1000 psi

Standard Line Bodies*

Code	Part No	Material	Pressure Rating	Weight
FH062-AS4	02600491	Aluminum, anodized	3500 psi (245 bar)	0.34 lbs (0.15 kg)
FH062-SS4	02600490	Steel, Zinc plated	6000 psi (420 bar)	1.0 lbs (0.45 kg)

*Please refer to Line Bodies & Cavities section for details

PRESSURE CONTROL VALVES

DB08A-01

Pressure Relief, Direct Acting, Poppet Type

10 gpm (38 l/min) • 6000 psi (420 bar)

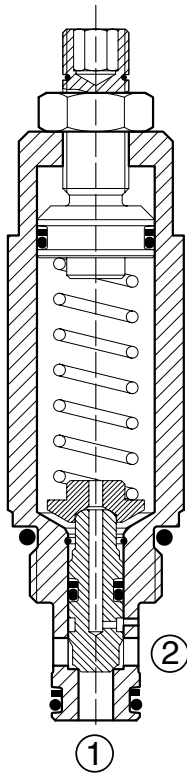
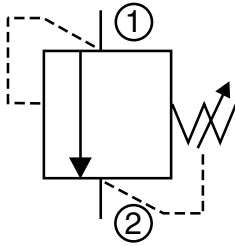

Description

A screw-in cartridge, direct acting, poppet type relief valve intended for use as pressure limiting device in hydraulic circuits which require low internal leakage and fast response to pressure changes.

Operation

The DB08A blocks flow from port 1 to port 2 until the pressure setting is reached at port 1 to lift the spring opposed poppet from its seat, allowing flow from port 1 to port 2. Pressure at port 2 is directly additive to valve pressure setting. Flow from port 2 to port 1 is checked.

Features

- Spring ranges up to 6000 psi (420 bar)
- Positive stop prevents spring from over adjustment (*options V,H*)
- Adjustable under full pressure
- Stroke limiting device for enhanced safety
- Fast response
- All external surfaces zinc-plated
- Hardened poppet to ensure minimal wear and extend service life
- One piece body maximizes reliability and minimizes the effects of eccentricity
- Industry common cavity

Specifications

Operating Pressure	6000 psi (420 bar)
Nominal Flow	10 gpm (38 l/min)
Internal Leakage	5 drops/min. (0.25 cc/min) max. to 80% of nominal setting
Reseat Pressure (Nominal)	80% of crack pressure
Optional Pressure Ranges	55 to 500 psi (4 to 35 bar) 95 to 900 psi (6.5 to 60 bar) 200 to 1800 psi (14 to 125 bar) 370 to 3300 psi (26 to 230 bar) 560 to 5000 psi (39 to 350 bar) 670 to 6000 psi (47 to 420 bar)
% of Spring Pressure Range Actuated at 1 Revolution (<i>Adjustment Type V, H</i>)	18%
Fluid Operating Temp. Range	-4° to 248°F (-20° to +120°C) (<i>Consult factory for usage at temp. outside range.</i>)
Fluid Compatibility	Mineral-based or synthetics with lubricating properties
Viscosity	50 to 2000 SUS (7.4 to 420 cSt)
Filtration	21/19/16 or cleaner (per ISO 4406). Use with filter rated $\beta_{10} \geq 200$.
Installation	No orientation restrictions
Cavity	FC08-2 (<i>see Line Bodies & Cavities section</i>)
Cavity Tools	Rougher: P/N: 02580090 Finisher: P/N: 02580091
Cartridge Weight	0.49 Lbs. (0.220 kg)
Cartridge Material	Steel with hardened work surfaces. Zinc-plated exposed surfaces. Anodized aluminum knobs. (<i>option H</i>) Buna N or Viton® o-rings, and PTFE back-up rings.
Seal Kits	Buna-N FS082-N P/N: 03033920 Viton® FS082-V P/N: 03051756

Performance

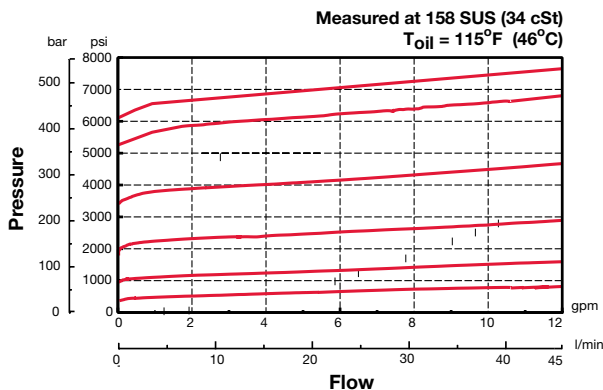

Dimensions

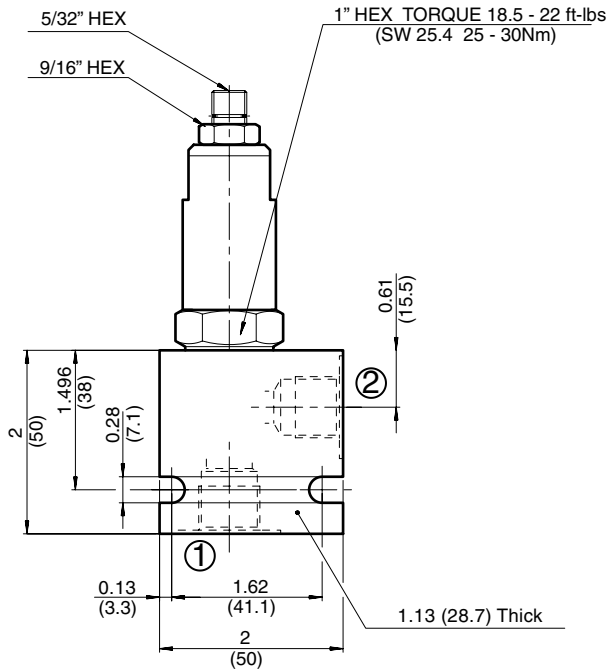

Model Code

DB08A-01-C-N-330 V 300

Valve Model

Body & Ports

- C = Cartridge only
- AS6 = SAE-6 ports, aluminum body
- SS6 = SAE-6 ports, steel body

Seals

- N = Buna-N
- V = Viton®

Adjustment Range

- 050 = 55 to 500 psi (4 to 35 bar)
- 090 = 95 to 900 psi (6.5 to 60 bar)
- 180 = 200 to 1800 psi (14 to 125 bar)
- 330 = 370 to 3300 psi (26 to 230 bar)
- 500 = 560 to 5000 psi (39 to 350 bar)
- 600 = 670 to 6000 psi (47 to 420 bar)

Adjustment Options

- F = Factory pre-set, non-adjustable
(*must specify setting below*)
- H = Knurled Hand Knob
- K = Allen Head (HEX 5/32") w/ cover cap
- V = Allen Head (HEX 5/32")

Setting (optional)

- (omit) = Set at min. pressure for the range
- XXX = Desired psi ÷ 10

Example: 300 = 3000 psi

Adjustment Options

'V' - Allen Head (std)

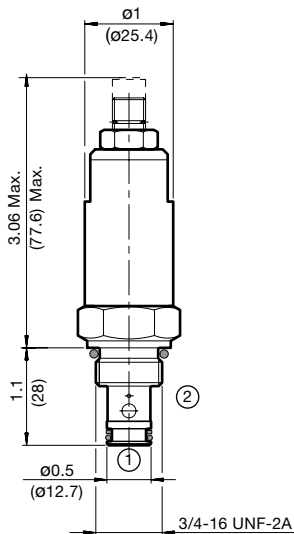

'H' - Hand Knob

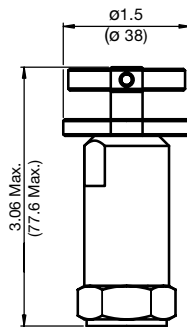

'K' - Protective Cap

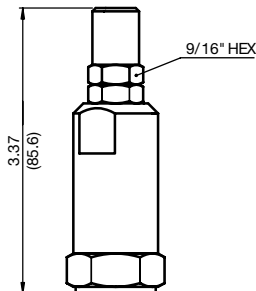

'F' - Tamper Proof Cap

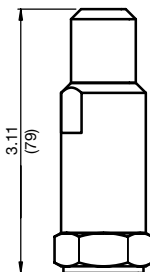

All measurements in inches (mm).
Subject to technical modifications

Standard Line Bodies*

Code	Part No	Material	Pressure Rating	Weight
FH082-AS6	03011409	Aluminum, anodized	3500 psi (245 bar)	0.34 lb (0.15 kg)
FH082-SS6	00560917	Steel, Zinc plated	6000 psi (420 bar)	1.00 lb (0.45 kg)

*Please refer to Line Bodies & Cavities section for details

PRESSURE CONTROL VALVES

DB08P-01

Pressure Relief, Pilot Operated, Spool Type

16 gpm (60 l/min) • 5000 psi (350 bar)

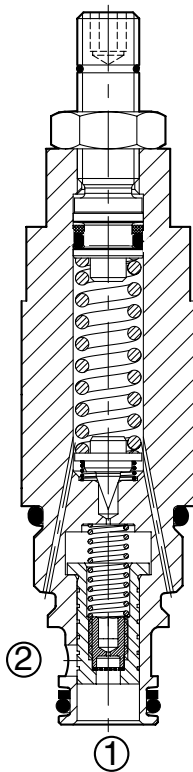
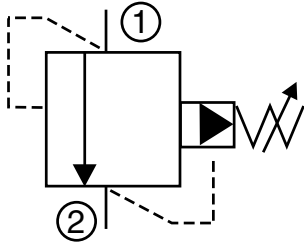

Description

A screw-in cartridge, pilot operated (two stage), spool type relief valve intended for use as a pressure limiting device in hydraulic circuits requiring fast response and low pressure rise over a wide flow range.

Operation

The DB08P blocks flow from port 1 to port 2 until the predetermined pressure setting is reached at port 1 to lift the spring opposed pilot poppet off its seat, creating a low flow and a pressure drop across the orifice in the main spool. This allows the main spool to shift, opening port 1 to port 2. Pressure at port 2 is directly additive to valve pressure setting.

Features

- Spring ranges up to 5000 psi (350 bar)
- Positive stop prevents spring from over adjustment (*options V,H*)
- Adjustable under full pressure
- One-piece body maximizes reliability & minimizes the effects of eccentricity
- Low pressure rise over flow range
- Screen protected pilot orifice to enhance safety
- Fast response with excellent stability
- All external surfaces zinc-plated
- Hardened spool & pilot poppet to ensure minimal wear & extend service life
- Industry common cavity

Specifications

Operating Pressure	5000 psi (350 bar)
Nominal Flow	16 gpm (60 l/min)
Internal Leakage	less than 30.5 cu in/min at 5000 psi (0.5 l/min at 350 bar)
Reseat Pressure (Nominal)	90% of crack pressure
Optional Pressure Ranges	60 to 500 psi (4 to 35 bar) 60 to 900 psi (4 to 60 bar) 60 to 1800 psi (4 to 125 bar) 60 to 3300 psi (4 to 230 bar) 60 to 5000 psi (4 to 350 bar)
% of Spring Pressure Range Actuated at 1 Revolution (<i>Adjustment Type V, H</i>)	24%
Fluid Operating Temp. Range	-4° to 248°F (-20° to +120°C) (Consult factory for usage at temp. outside range.)
Fluid Compatibility	Mineral-based or synthetics with lubricating properties
Viscosity	50 to 2000 SUS (7.4 to 420 cSt)
Filtration	21/19/16 or cleaner (per ISO 4406). Use with filter rated $\beta_{10} \geq 200$.
Installation	No orientation restrictions
Cavity	FC08-2 (<i>see Line Bodies & Cavities section</i>)
Cavity Tools	Rougher: 02580090 Finisher: 02580091
Cartridge Weight	0.31 Lbs. (0.14 kg)
Cartridge Material	Steel with hardened work surfaces. Zinc-plated exposed surfaces. Anodized aluminum knobs. (<i>option H</i>) Buna N or Viton® o-rings and PTFE back-up rings.
Seal Kits	Buna-N FS082-N P/N: 03033920 Viton® FS082-V P/N: 03051756

Performance

Measured at 158 SUS (34 cSt)
Toil= 115°F (46°C)

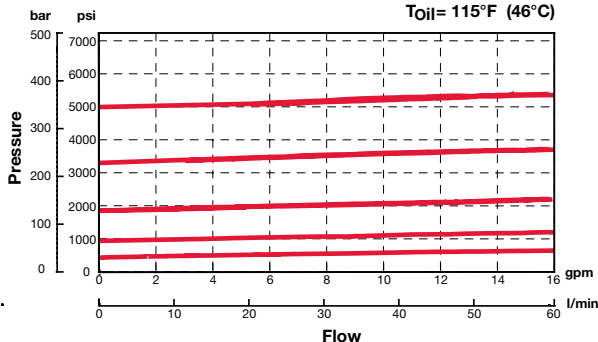

Dimensions

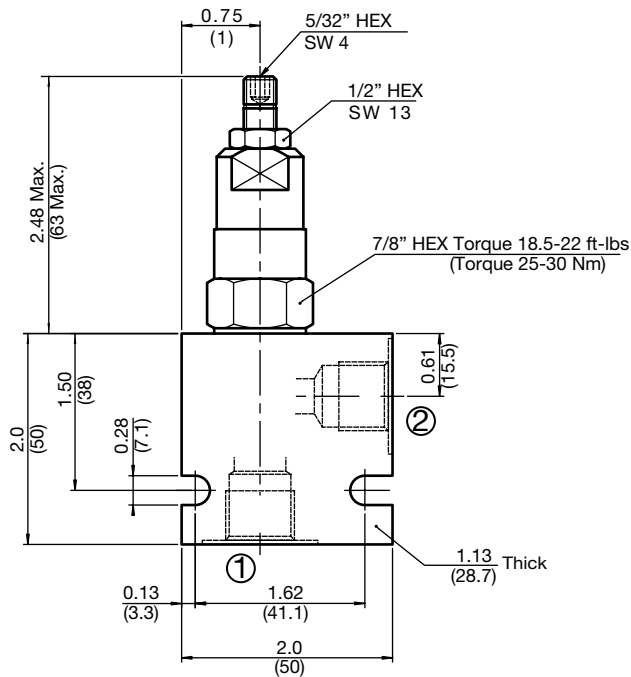

Model Code

DB08P-01-C-N-330 V 300

Valve Model

Body & Ports

- C = Cartridge only
- AS6 = SAE-6 ports, aluminum body
- SS6 = SAE-6 ports, steel body

Seals

- N = Buna-N
- V = Viton®

Adjustment Range

- 050 = 60 to 500 psi (4 to 35 bar)
- 090 = 60 to 900 psi (4 to 60 bar)
- 180 = 60 to 1800 psi (4 to 125 bar)
- 330 = 60 to 3300 psi (4 to 230 bar)
- 500 = 60 to 5000 psi (4 to 350 bar)

Adjustment Options

- F = Factory pre-set, non-adjustable
(must specify setting below)
- H = Knurled Hand Knob
- K = Allen Head (HEX 5/32") w/ cover cap
- V = Allen Head (HEX 5/32")

Setting (optional)

- (omit)* = Set at min. pressure for the range
- XXX = Desired psi ÷ 10

Example: 300 = 3000 psi

Adjustment Options

'V' - Allen Head (std)

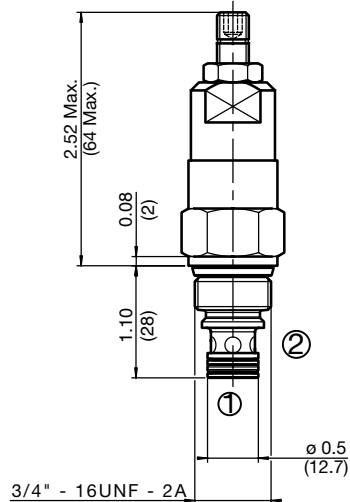

'H' - Hand Knob

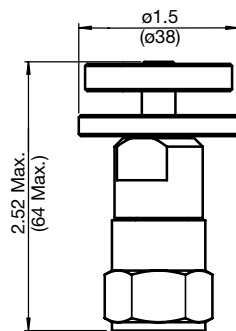

'K' - Protective Cap

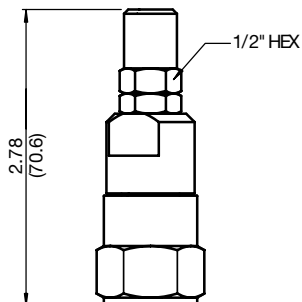

'F' - Tamper Proof Cap

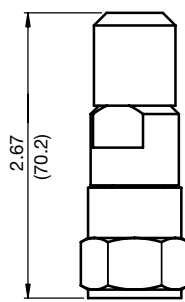

All measurements in inches (mm).
Subject to technical modifications

Standard Line Bodies*

Code	Part No	Material	Pressure Rating	Weight
FH082-AS6	03011409	Aluminum, anodized	3500 psi (245 bar)	0.34 lb (0.15 kg)
FH082-SS6	00560917	Steel, Zinc plated	6000 psi (420 bar)	1.00 lb (0.45 kg)

*Please refer to Line Bodies & Cavities section for details

PRESSURE CONTROL VALVES

DB10P-01

Pressure Relief, Pilot Operated, Spool Type

Up to 32 gpm (120 l/min) • 6000 psi (420 bar)

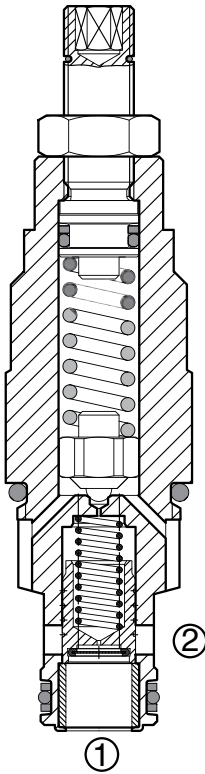
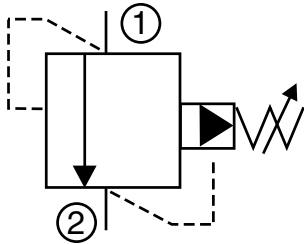

Description

A screw-in cartridge, pilot operated (two stage), spool type relief valve intended for use as a pressure limiting device in hydraulic circuits requiring fast response and low pressure rise over a wide flow range.

Operation

The DB10P blocks flow from port 1 to port 2 until the pressure setting is reached at port 1 to lift the pilot poppet creating a pressure drop across the main spool. This allows the main spool to shift, opening port 1 to port 2. Pressure at port 2 is directly additive to valve pressure setting.

Features

- Spring ranges up to 6000 psi (420 bar)
- Positive stop prevents spring from over adjustment (options V,H)
- Adjustable under full pressure
- One-piece body maximizes reliability and minimizes the effect of eccentricity
- Screen protected control orifice to enhance safety
- Fast response with excellent stability
- All external surfaces zinc-plated
- Hardened spool & pilot poppet to ensure minimal wear & extend service life
- Industry common cavity

Specifications

Operating Pressure	6000 psi (420 bar)
Nominal Flow	32 gpm (120 l/min)
Internal Leakage	less than 30.5 cu in/min at 5000 psi (0.5 l/min at 350 bar)
Reseat Pressure (Nominal)	90% of crack pressure
Optional Pressure Ranges	60 to 500 psi (4 to 35 bar) 60 to 900 psi (4 to 60 bar) 60 to 1800 psi (4 to 125 bar) 60 to 3300 psi (4 to 230 bar) 60 to 5000 psi (4 to 350 bar) 60 to 6000 psi (4 to 420 bar)
% of Spring Pressure Range Actuated at 1 Revolution (Adjustment Type V, H)	24%
Fluid Operating Temp. Range	-4° to 248°F (-20° to +120°C) (Consult factory for usage at temp. outside range.)
Fluid Compatibility	Mineral-based or synthetics with lubricating properties
Viscosity	50 to 2000 SUS (7.4 to 420 cSt)
Filtration	21/19/16 or cleaner (per ISO 4406). Use with filter rated $\beta_{10} \geq 200$.
Installation	No orientation restrictions
Cavity	FC10-2 (see <i>Line Bodies & Cavities</i> section)
Cavity Tools	Rougher: 02580274 Finisher: 02580247
Cartridge Weight	0.44 Lbs. (0.200 kg)
Cartridge Material	Steel with hardened work surfaces. Zinc-plated exposed surfaces. Anodized aluminum knobs. (option H) Buna N or Viton® o-rings and PTFE back-up rings.
Seal Kits	Buna-N P/N: 03033872 Viton® P/N: 03051757

Performance

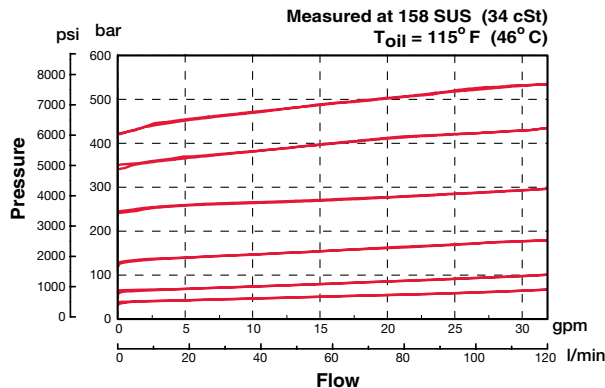

Dimensions

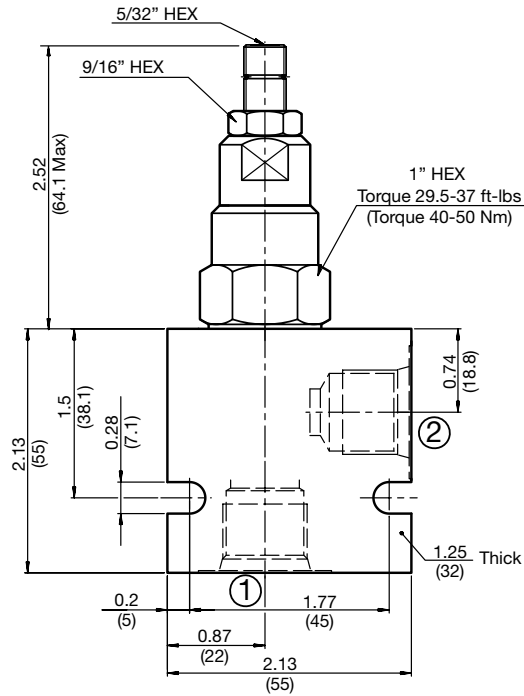

Model Code

DB10P-01-C-N-180 V 100

Valve Model

Body & Ports

- C = Cartridge only
- AS8 = SAE-8 ports, aluminum body
- SS8 = SAE-8 ports, steel body

Seals

- N = Buna-N
- V = Viton®

Adjustment Range

- 050 = 60 to 500 psi (4 to 35 bar)
- 090 = 60 to 900 psi (4 to 60 bar)
- 180 = 60 to 1800 psi (4 to 125 bar)
- 330 = 60 to 3300 psi (4 to 230 bar)
- 500 = 60 to 5000 psi (4 to 350 bar)
- 600 = 60 to 6000 psi (4 to 420 bar)

Adjustment Options

- F = Factory pre-set, non-adjustable
(must specify setting below)
- H = Knurled Hand Knob
- K = Allen Head (HEX 5/32") w/ cover cap
- V = Allen Head (HEX 5/32")

Setting (optional)

- (omit) = Set at min. pressure for the range
- XXX = Desired psi ÷ 10

Example: 300 = 3000 psi

Adjustment Options

'V' - Allen Head (std)

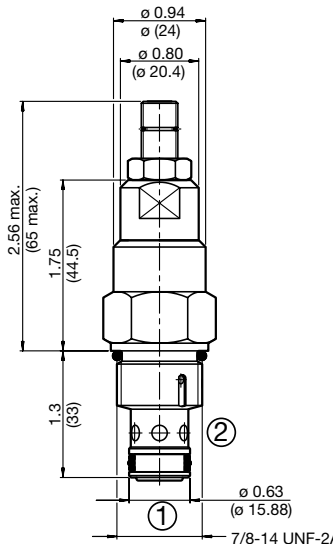

'H' - Hand Knob

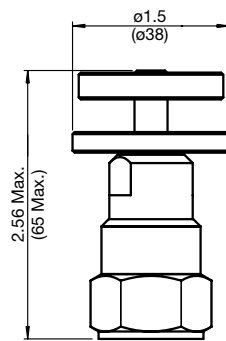

'K' - Protective Cap

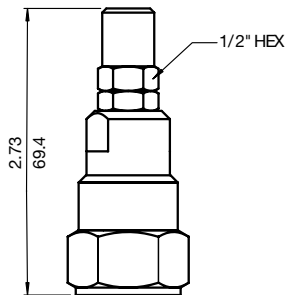

'F' - Tamper Proof Cap

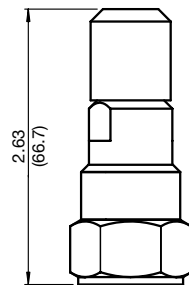

All measurements in inches (mm).
Subject to technical modifications

Standard Line Bodies*

Code	Part No	Material	Pressure Rating	Weight
FH102-AS8	03037778	Aluminum, anodized	3500 psi (245 bar)	0.40 lb (0.18 kg)
FH102-SS8	03037612	Steel, Zinc plated	6000 psi (420 bar)	1.16 lb (0.53 kg)

*Please refer to Line Bodies & Cavities section for details

PRESSURE CONTROL VALVES

DB12P-01

Pressure Relief, Pilot Operated, Spool Type

Up to 53 gpm (200 l/min) • 5000 psi (350 bar)

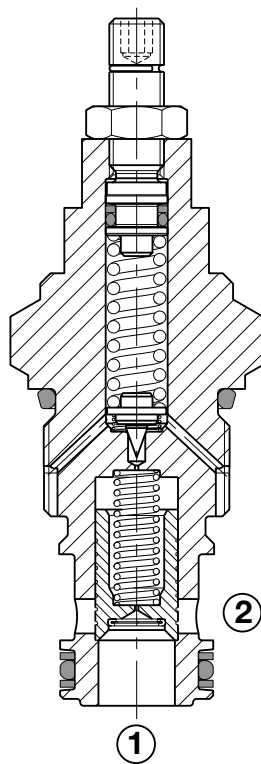
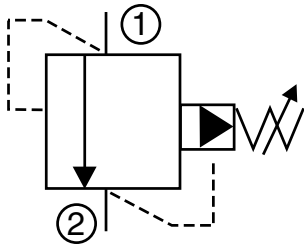

Description

A screw-in cartridge, pilot operated (two stage), spool type relief valve intended for use as pressure limiting device in hydraulic circuits requiring fast response and low pressure rise in a wide flow range.

Operation

The DB12P blocks flow from port 1 to port 2 until the pressure setting is reached at port 1 to lift the pilot poppet, creating a pressure drop across the main spool. This allows the main spool to shift, opening port 1 to port 2. Pressure at port 2 is directly additive to valve pressure setting.

Features

- Spring ranges up to 5000 psi (350 bar)
- Positive stop prevents spring from over adjustment (options V,H)
- Adjustable under full pressure
- One-piece body maximizes reliability and minimizes the effect of eccentricity
- Low pressure drop due to an optimized flow-path
- Screen protected pilot control orifice to enhance safety
- Fast response with excellent stability
- All external surfaces zinc-plated
- Hardened spool & pilot poppet to ensure minimal wear & extend service life
- Industry common cavity

Specifications

Operating Pressure	5000 psi (350 bar)
Nominal Flow	53 gpm (200 l/min)
Internal Leakage	less than 30.5 cu in/min at 5000 psi (0.5 l/min at 350 bar)
Reseat Pressure (Nominal)	90% of crack pressure
Optional Pressure Ranges	45 to 500 psi (3 to 35 bar) 45 to 900 psi (3 to 60 bar) 45 to 1800 psi (3 to 125 bar) 60 to 3300 psi (4 to 230 bar) 60 to 5000 psi (4 to 350 bar)
% of Spring Pressure Range Actuated at 1 Revolution (Adjustment Type V, H)	24%
Fluid Operating Temp. Range	-4° to 248°F (-20° to +120°C) (Consult factory for usage at temp. outside range.)
Fluid Compatibility	Mineral-based or synthetics with lubricating properties
Viscosity	50 to 2000 SUS (7.4 to 420 cSt)
Filtration	21/19/16 or cleaner (per ISO 4406). Use with filter rated $\beta_{10} \geq 200$.
Installation	No orientation restrictions
Cavity	FC12-2 (see Line Bodies & Cavities section)
Cavity Tools	Rougher: 02580667 Finisher: 02580668
Cartridge Weight	0.59 Lbs. (0.270 kg)
Cartridge Material	Steel with hardened work surfaces. Zinc-plated exposed surfaces. Anodized aluminum knobs. (option H) Buna N or Viton® o-rings, and PTFE back-up rings.
Seal Kits	Buna-N FS122-N P/N: 03071298 Viton® FS122-V P/N: 03071299

Performance

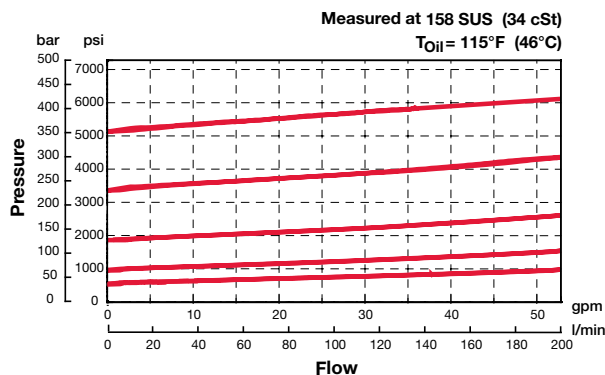

PRESSURE CONTROL VALVES

Dimensions

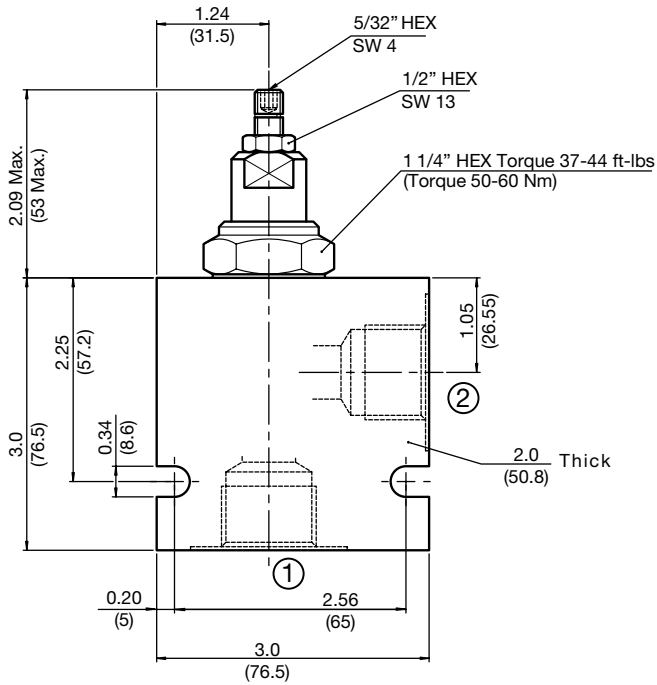

Model Code

DB12P-01-C-N-180 V 100

Valve Model

Body & Ports

- C = Cartridge only
- AS12 = SAE-12 ports, aluminum body
- SS12 = SAE-12 ports, steel body

Seals

- N = Buna-N
- V = Viton®

Adjustment Range

- 050 = 45 to 500 psi (3 to 35 bar)
- 090 = 45 to 900 psi (3 to 60 bar)
- 180 = 45 to 1800 psi (3 to 125 bar)
- 330 = 60 to 3300 psi (4 to 230 bar)
- 500 = 60 to 5000 psi (4 to 350 bar)

Adjustment Options

- F = Factory pre-set, non-adjustable
(must specify setting below)
- H = Knurled Hand Knob
- K = Allen Head (HEX 5/32") w/ cover cap
- V = Allen Head (HEX 5/32")

Setting *(optional)*

- (omit)* = Set at min. pressure for the range
- XXX = Desired psi ÷ 10

Example: 300 = 3000 psi

Adjustment Options

'V' - Allen Head (std)

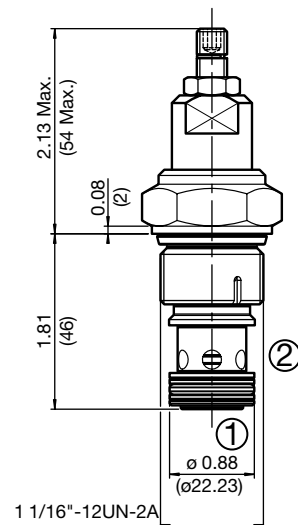

'H' - Hand Knob

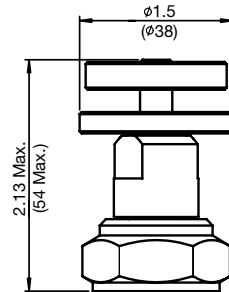

'K' - Protective Cap

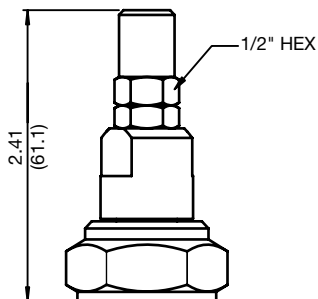

'F' - Tamper Proof Cap

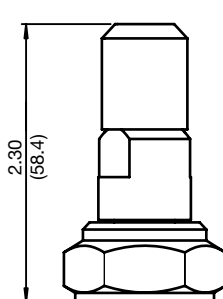

All measurements in inches (mm).
Subject to technical modifications

Standard Line Bodies*

Code	Part No	Material	Pressure Rating	Weight
FH122-AS12	03053845	Aluminum, anodized	3500 psi (245 bar)	1.39 lb (0.63 kg)
FH122-SS12	03053772	Steel, Zinc plated	6000 psi (420 bar)	4.16 lb (1.89 kg)

*Please refer to Line Bodies & Cavities section for details

PRESSURE CONTROL VALVES

DB16P-01

Pressure Relief, Pilot Operated, Spool Type

Up to 79 gpm (300 l/min) • 5000 psi (350 bar)

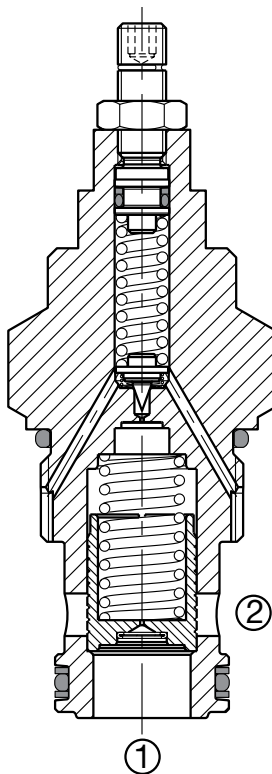
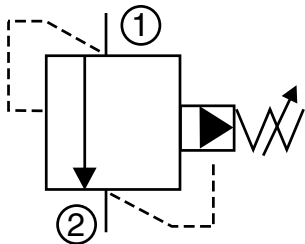

Description

A screw-in cartridge, pilot operated (two stage), spool type relief valve intended for use as pressure limiting device in hydraulic circuits requiring fast response and low pressure rise in a wide flow range.

Operation

The DB16P blocks flow from port 1 to port 2 until the pressure setting is reached at port 1 to lift the pilot poppet creating a pressure drop across the main spool. This allows the main spool to shift, opening port 1 to port 2. Pressure at port 2 is directly additive to valve pressure setting.

Features

- Spring ranges up to 5000 psi (350 bar)
- Positive stop prevents spring from over adjustment (options V,H)
- Adjustable under full pressure
- One-piece body maximizes reliability and minimizes the effect of eccentricity
- Low pressure drop due to an optimized flow-path
- Screen protected control orifice to enhance safety
- Fast response with excellent stability
- All external surfaces zinc-plated
- Hardened spool & pilot poppet to ensure minimal wear & extend service life
- Industry common cavity

Specifications

Operating Pressure	5000 psi (350 bar)
Nominal Flow	79 gpm (300 l/min)
Internal Leakage	less than 61 cu in/min at 5000 psi (1 l/min at 350 bar)
Reseat Pressure (Nominal)	90% of crack pressure
Optional Pressure Ranges	45 to 500 psi (3 to 35 bar) 45 to 900 psi (3 to 60 bar) 45 to 1800 psi (3 to 125 bar) 60 to 3300 psi (4 to 230 bar) 60 to 5000 psi (4 to 345 bar)
% of Spring Pressure Range Actuated at 1 Revolution (Adjustment Type V, H)	24%
Fluid Operating Temp. Range	-4° to 248°F (-20° to +120°C) (Consult factory for usage at temp. outside range.)
Fluid Compatibility	Mineral-based or synthetics with lubricating properties
Viscosity	50 to 2000 SUS (7.4 to 420 cSt)
Filtration	21/19/16 or cleaner (per ISO 4406).
Installation	No orientation restrictions
Cavity	FC16-2 (see Line Bodies & Cavities section)
Cavity Tools	Rougher: 02580250 Finisher: 02580251
Cartridge Weight	1.0 Lbs. (0.465 kg)
Cartridge Material	Steel with hardened work surfaces. Zinc-plated exposed surfaces. Anodized aluminum knobs. (option H) Buna N or Viton® o-rings, and PTFE back-up rings.
Seal Kits	Buna-N P/N: 03052427 Viton® P/N: 03051758

Performance

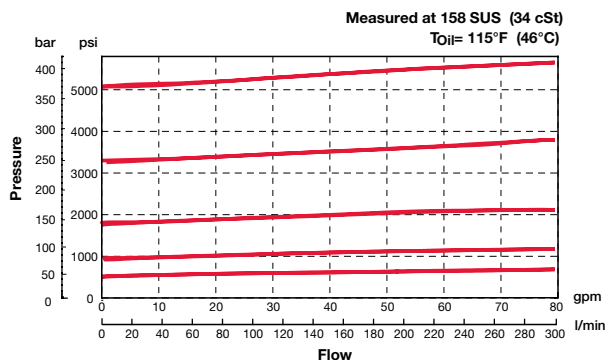

PRESSURE CONTROL VALVES

Dimensions

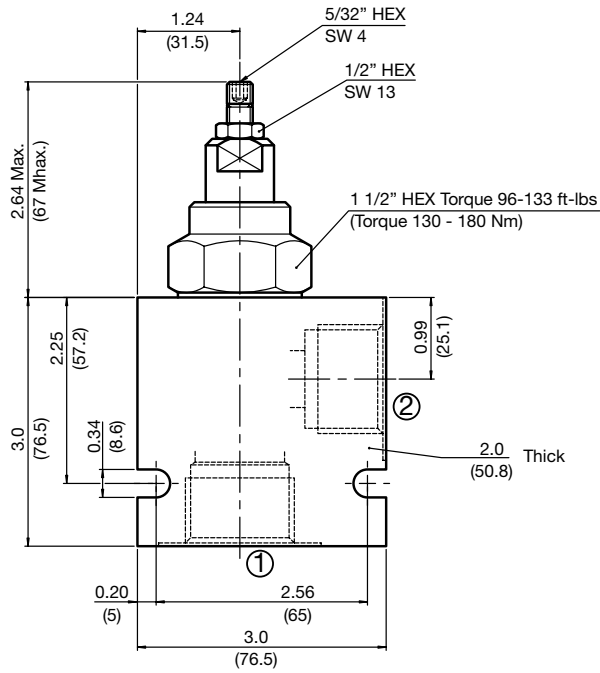

Model Code

DB16P-01-C-N-180 V 100

Valve Model

Body & Ports

- C = Cartridge only
- AS16 = SAE-16 ports, aluminum body
- SS16 = SAE-16 ports, steel body

Seals

- N = Buna-N
- V = Viton®

Adjustment Range

- 050 = 45 to 500 psi (3 to 35 bar)
- 090 = 45 to 870 psi (3 to 60 bar)
- 180 = 45 to 1800 psi (3 to 125 bar)
- 330 = 60 to 3300 psi (4 to 230 bar)
- 500 = 60 to 5000 psi (4 to 350 bar)

Adjustment Options

- F = Factory pre-set, non-adjustable
(must specify setting below)
- H = Knurled Hand Knob
- K = Allen Head (HEX 5/32") w/ cover cap
- V = Allen Head (HEX 5/32")

Setting *(optional)*

- (omit)* = Set at min. pressure for the range
- XXX = Desired psi ÷ 10

Example: 300 = 3000 psi

Adjustment Options

'V' - Allen Head (std)

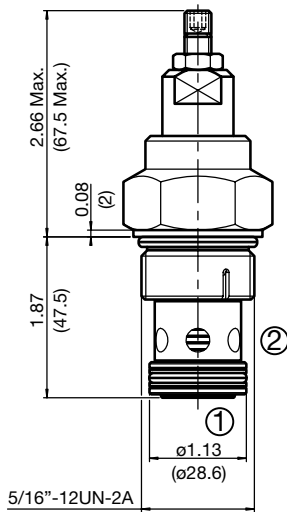

'H' - Hand Knob

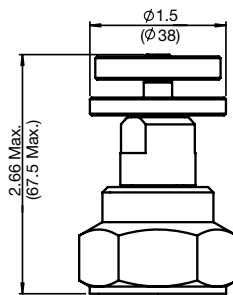

'K' - Protective Cap

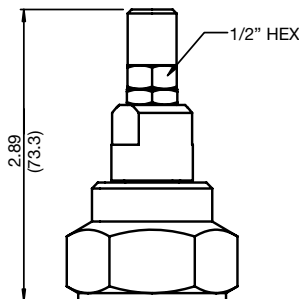

'F' - Tamper Proof Cap

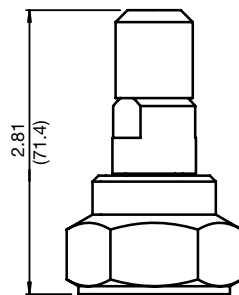

All measurements in inches (mm).
Subject to technical modifications

Standard Line Bodies*

Code	Part No	Material	Pressure Rating	Weight
FH162-AS16	03037195	Aluminum, anodized	3500 psi (245 bar)	1.20 lb (0.55 kg)
FH162-SS16	03032655	Steel, Zinc plated	6000 psi (420 bar)	3.56 lb (1.62 kg)

*Please refer to Line Bodies & Cavities section for details

PRESSURE CONTROL VALVES

DR08-01

Pressure Reducing/Relieving, Direct Acting, Spool Type

4 gpm (15 l/min) • 6000 psi (420 bar)

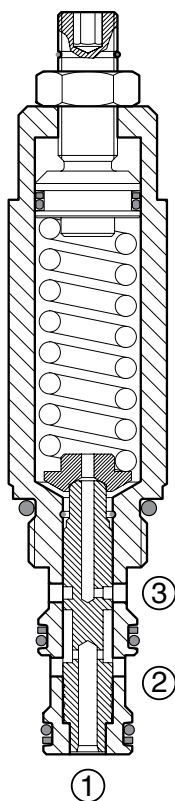
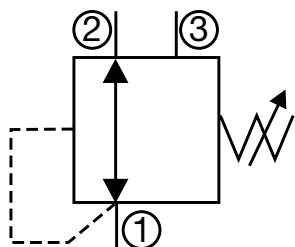

Description

A screw-in cartridge, direct acting, spool type, pressure reducing/relieving valve with internal spring chamber drain, intended for use as a pressure regulating device. This valve maintains a constant secondary regulated/ reduced pressure regardless of pressure variations in the primary system. In addition to the reducing function, this valve also provides a relief function from the reduced pressure port to the tank port, if pressure in the secondary circuit exceeds the set pressure.

Operation

The DR08-01 allows bidirectional flow between port 2 and port 1 with the spring chamber drained through port 3. Once the pressure setting is reached at port 1, the spool shifts to restrict the flow at port 2, thereby regulating pressure at port 1. If pressure at port 1 exceeds the setting of the valve, the spool will shift further and relieve excess pressure through port 3. Any pressure at port 3 is directly additive to valve pressure.

Features

- Spring ranges up to 3000 psi (210 bar)
- Positive stop prevents spring from over adjustment (*options V,H*)
- Adjustable under full pressure
- Stroke limiting device for enhanced safety
- Fast response
- All external surfaces zinc-plated
- Hardened poppet to ensure minimal wear and extend service life
- Industry common cavity

Specifications

Operating Pressure	6000 psi (420 bar)
Nominal Flow	4 gpm (15 l/min)
Optional Pressure Ranges	50 to 500 psi (3 to 35 bar) 363 to 1200 psi (25 to 83 bar) 653 to 2200 psi (45 to 152 bar) 1073 to 3000 psi (74 to 210 bar)
% of Spring Pressure Range Actuated at 1 Revolution (Adjustment Type V, H)	14%
Fluid Operating Temp. Range	-4° to 248°F (-20° to +120°C) <i>*Consult factory for usage at temp. outside range</i>
Fluid Compatibility	Mineral-based or synthetics with lubricating properties
Viscosity	50 to 2000 SUS (7.4 to 420 cSt)
Filtration	21/19/16 or cleaner (per ISO 4406). Use with filter rated $\beta_{10} \geq 200$.
Installation	No orientation restrictions
Cavity	FC08-3 (<i>see Line Bodies & Cavities section</i>)
Cavity Tools	Rougher: 02580086 Finisher: 02580087
Cartridge Weight	0.52 Lbs. (0.235 kg)
Cartridge Material	Steel with hardened work surfaces. Zinc-plated exposed surfaces. Anodized aluminum knobs. (<i>option H</i>) Buna N or Viton® o-rings, and PTFE back-up rings.
Seal Kits	Buna-N P/N: 03054795 Viton® P/N: 02591059

Performance

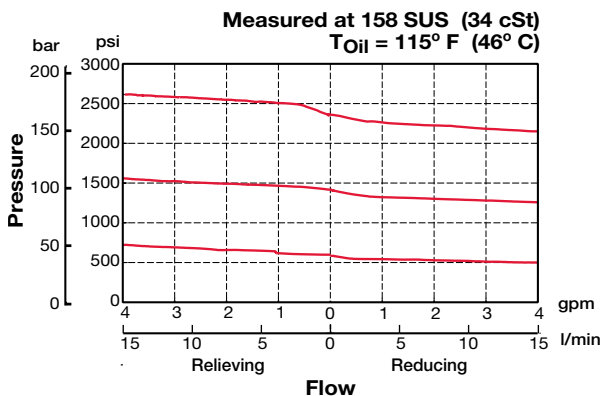

Dimensions

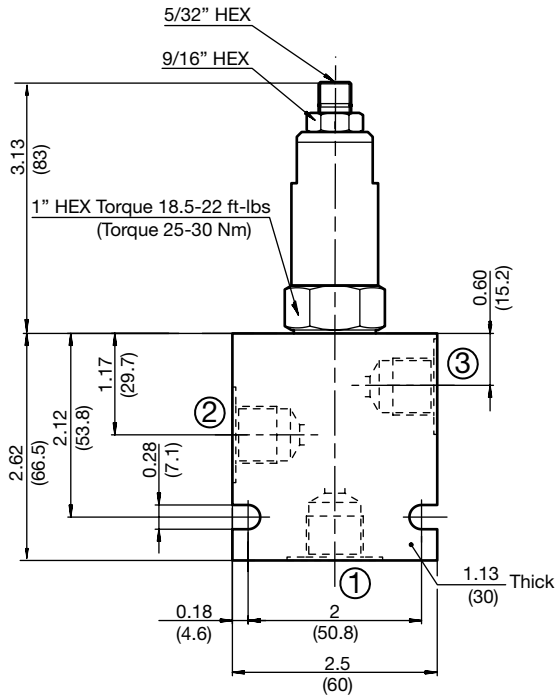

Model Code

DR08-01-C-N-220 V 200

Valve Model

Body & Ports

- C = No Line Body, cartridge only
- AS6 = SAE-6 ports, aluminum body
- SS6 = SAE-6 ports, steel body

Seals

- N = Buna-N
- V = Viton®

Adjustment Range

- 050 = 50 to 500 psi (3.5 to 35 bar)
- 120 = 363 to 1200 psi (25 to 83 bar)
- 220 = 653 to 2200 psi (45 to 152 bar)
- 300 = 1073 to 3000 psi (74 to 210 bar)

Adjustment Options

- F = Factory pre-set, non-adjustable
(must specify setting below)
- H = Knurled Hand Knob
- K = Allen Head (HEX 5/32") w/ cover cap
- V = Allen Head (HEX 5/32")

Setting (optional)

- (omit) = Set at min. pressure for the range
- XXX = Desired psi ÷ 10

Example: 200 = 2000 psi

Adjustment Options

'V' - Allen Head (std)

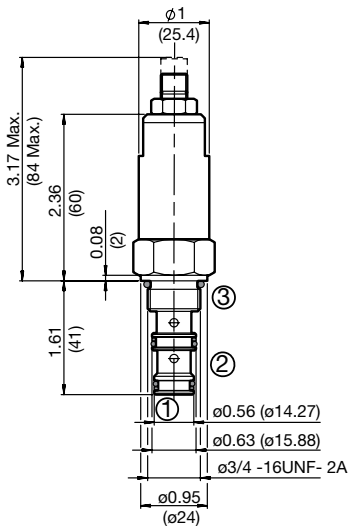

'H' - Hand Knob

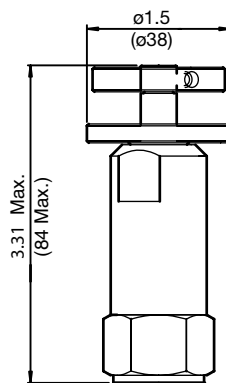

'K' - Protective Cap

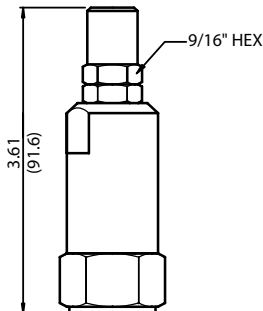

'F' - Tamper Proof Cap

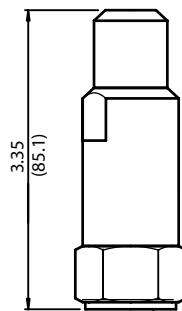

All measurements in inches (mm).
Subject to technical modifications

Standard Line Bodies*

Code	Part No	Material	Pressure Rating	Weight
FH083-AS6	03011424	Aluminum, anodized	3500 psi (245 bar)	0.58 lb (0.26 kg)
FH083-SS6	00560920	Steel, Zinc plated	6000 psi (420 bar)	1.70 lb (0.77 kg)

*Please refer to Line Bodies & Cavities section for details

PRESSURE CONTROL VALVES

DR10-01

Pressure Reducing/Relieving, Direct Acting, Spool Type

Up to 16 gpm (60 l/min) • 6000 psi (420 bar)

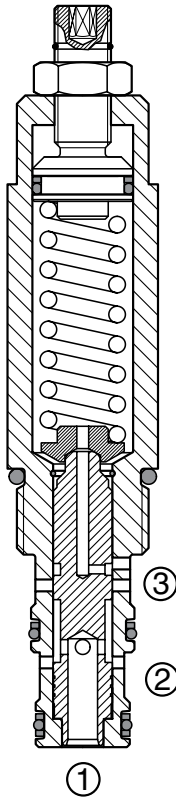
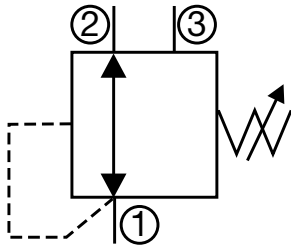

Description

A screw-in cartridge, direct acting, spool type, pressure reducing/relieving valve with internal spring chamber drain, intended for use as a pressure regulating device. This valve maintains a secondary regulated/reduced pressure regardless of pressure variations in the primary system. In addition to the reducing function, this valve also provides a relief function from the reduced pressure port to the tank port, if pressure in the secondary circuit exceeds the set pressure.

Operation

The DR10-01 allows bidirectional flow between port 2 and port 1 with the spring chamber drained through port 3. Once the pressure setting is reached at port 1, the spool shifts to restrict the flow at port 2, thereby regulating pressure at port 1. If pressure at port 1 exceeds the setting of the valve, the spool will shift further and relieve excess pressure through port 3. Any pressure at port 3 is directly additive to valve pressure setting.

Features

- Spring ranges up to 1900 psi (131 bar)
- Positive stop prevents spring from over adjustment (options V,H)
- Adjustable under full pressure
- Stroke limiting device for enhanced safety
- Fast response
- All external surfaces zinc-plated
- Hardened poppet to ensure minimal wear and extend service life
- Industry common cavity

Specifications

Operating Pressure	6000 psi (420 bar)
Nominal Flow	16 gpm (60 l/min)
Optional Pressure Ranges	236 to 700 psi (17 to 48 bar) 435 to 1400 psi (30 to 96 bar) 725 to 1900 psi (50 to 131 bar)
% of Spring Pressure Range Actuated at 1 Revolution (Adjustment Type V, H)	14%
Fluid Operating Temp. Range	-4° to 248°F (-20° to +120°C) (Consult factory for usage at temp. outside range.)
Fluid Compatibility	Mineral-based or synthetics with lubricating properties
Viscosity	50 to 2000 SUS (7.4 to 420 cSt)
Filtration	21/19/16 or cleaner (per ISO 4406). Use with filter rated $\beta_{10} \geq 200$.
Installation	No orientation restrictions
Cavity	FC10-3 (see Line Bodies & Cavities section)
Cavity Tools	Rougher: 02580092 Finisher: 02580093
Cartridge Weight	0.58 Lbs. (0.262 kg)
Cartridge Material	Steel with hardened work surfaces. Zinc-plated exposed surfaces. Anodized aluminum knobs. (option H) Buna N or Viton® o-rings, and PTFE back-up rings.
Seal Kits	Buna-N P/N: 03071274 Viton® P/N: 03049443

Performance

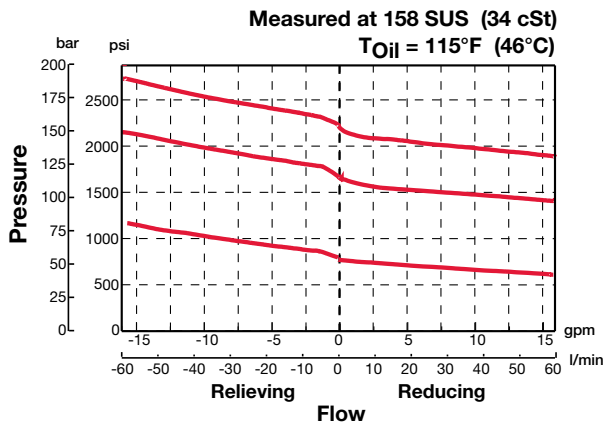

Dimensions

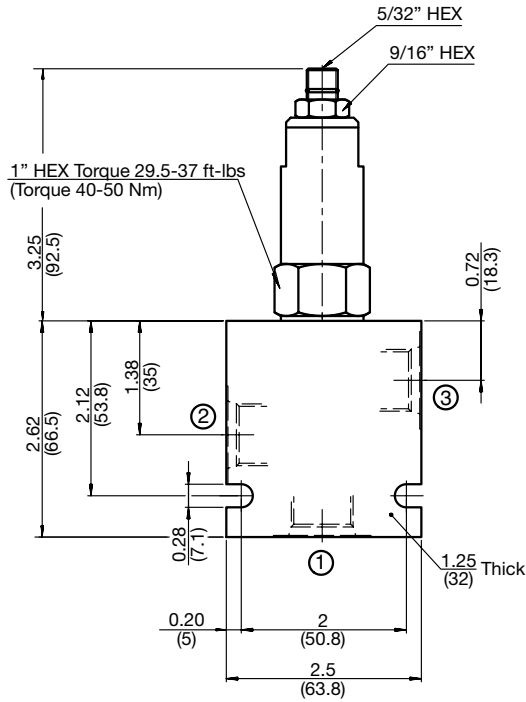

Model Code

DR10-01-C-N-070 V 050

Valve Model

Body & Ports

- C = Cartridge only
- AS6 = SAE-8 ports, aluminum body
- SS6 = SAE-8 ports, steel body

Seals

- N = Buna-N
- V = Viton®

Adjustment Range

- 070 = 246 to 700 psi (17 to 48 bar)
- 140 = 435 to 1400 psi (30 to 96 bar)
- 190 = 725 to 1900 psi (50 to 131 bar)

Adjustment Options

- F = Factory pre-set, non-adjustable
(must specify setting below)
- H = Knurled Hand Knob
- K = Allen Head (HEX 5/32") w/ cover cap
- V = Allen Head (HEX 5/32")

Setting (optional)

- (omit) = Set at min. pressure for the range
- XXX = Desired psi ÷ 10

Example: 050 = 500 psi

Adjustment Options

'V' - Allen Head (std)

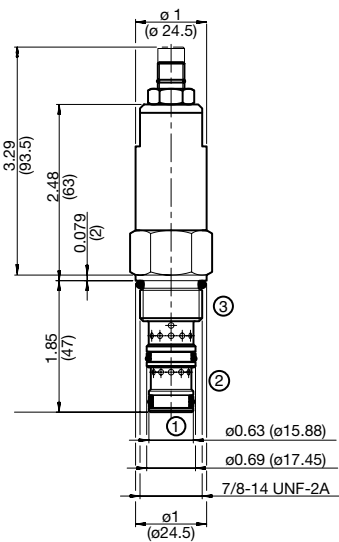

'H' - Hand Knob

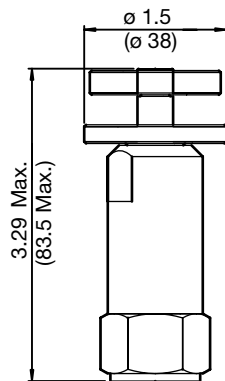

'K' - Protective Cap

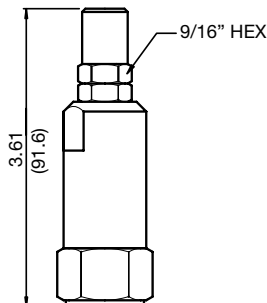

'F' - Tamper Proof Cap

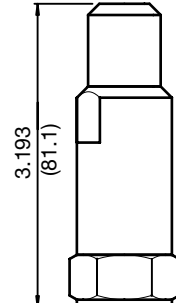

All measurements in inches (mm).
Subject to technical modifications

Standard Line Bodies*

Code	Part No	Material	Pressure Rating	Weight
FH103-AS8	03038095	Aluminum, anodized	3500 psi (245 bar)	0.60 lb (0.27 kg)
FH103-SS8	03037704	Steel, Zinc plated	6000 psi (420 bar)	1.74 lb (0.79 kg)

*Please refer to Line Bodies & Cavities section for details

PRESSURE CONTROL VALVES

DR08P-01

Pressure Reducing/Relieving, Pilot Operated, Spool Type

16 gpm (60 l/min) • 5000 psi (350 bar)

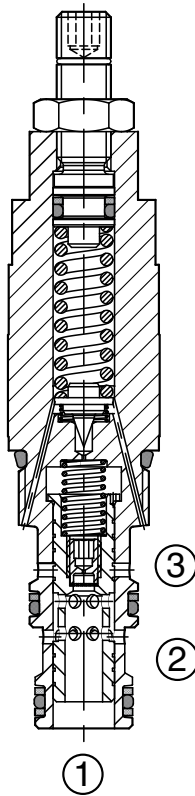
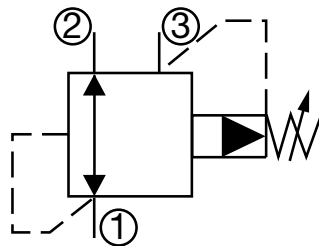

Description

A screw-in cartridge, pilot operated, spool type, pressure reducing/relieving valve with internal pilot and internal spring chamber drain, intended for use as a pressure regulating device for secondary circuits. This valve maintains a secondary regulated/reduced pressure regardless of pressure variations in the primary system. In addition to the reducing function, this valve also provides a relief function from the reduced pressure port to the tank port, if pressure in the secondary circuit exceeds the set pressure.

Operation

The DR08P-01 allows bidirectional flow between port 2 and port 1 with the spring chamber drained through port 3. Once the pressure setting is reached at port 1, the spool shifts to restrict the flow at port 2, thereby regulating pressure at port 1. If pressure at port 1 exceeds the setting of the valve, the spool will shift further and relieve excess pressure through port 3. Any pressure at port 3 is directly additive to valve pressure setting.

Features

- Spring ranges up to 5000 psi (350 bar)
- Positive stop prevents spring from over adjustment (options V,H)
- Adjustable under full pressure
- One-piece body maximizes reliability and minimizes the effect of eccentricity
- Screen protected control orifice to enhance safety
- Fast response with excellent stability
- All external surfaces zinc-plated
- Hardened spool & pilot poppet to ensure minimal wear & extend service life
- Industry common cavity

Specifications

Operating Pressure	5000 psi (350 bar)
Nominal Flow	16 gpm (60 l/min)
Optional Pressure Ranges	75 to 500 psi (5 to 35 bar) 75 to 900 psi (5 to 60 bar) 75 to 1800 psi (5 to 125 bar) 75 to 3300 psi (5 to 230 bar) 75 to 5000 psi (5 to 350 bar)
% of Spring Pressure Range Actuated at 1 Revolution (Adjustment Type V, H)	24%
Fluid Operating Temp. Range	-4° to 248°F (-20° to +120°C) (Consult factory for usage at temp. outside range.)
Fluid Compatibility	Mineral-based or synthetics with lubricating properties
Viscosity	50 to 2000 SUS (7.4 to 420 cSt)
Filtration	21/19/16 or cleaner (per ISO 4406). Use with filter rated $\beta_{10} \geq 200$.
Installation	No orientation restrictions
Cavity	FC08-3 (see Line Bodies & Cavities section)
Cavity Tools	Rougher: 02580086 Finisher: 02580087
Cartridge Weight	0.38 Lbs. (0.170 kg)
Cartridge Material	Steel with hardened work surfaces. Zinc-plated exposed surfaces. Anodized aluminum knobs. (option H) Buna N or Viton® o-rings, and PTFE back-up rings.
Seal Kits	Buna-N P/N: 03054795 Viton® P/N: 02591059

Performance

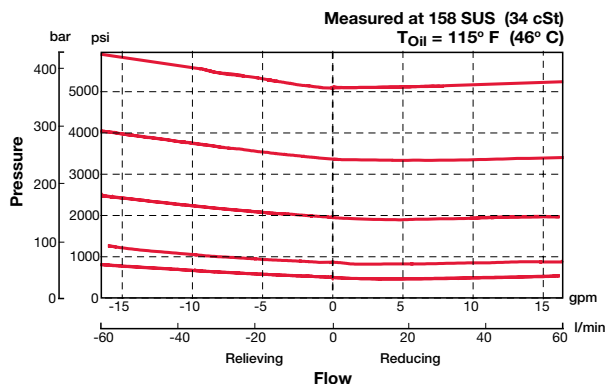

Dimensions

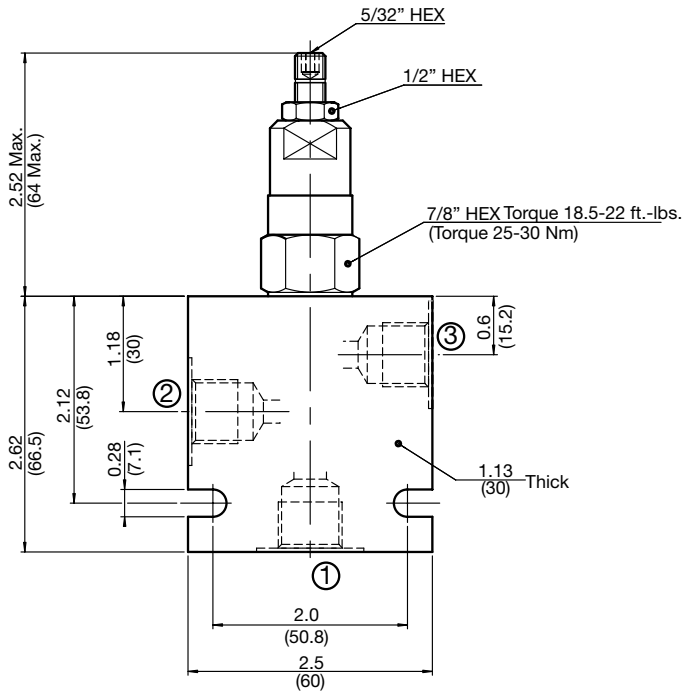

Model Code

DR08P-01-C-N-180 V 100

Valve Model

Body & Ports

- C = Cartridge only
- AS6 = SAE-6 ports, aluminum body
- SS6 = SAE-6 ports, steel body

Seals

- N = Buna-N
- V = Viton®

Adjustment Range

- 050 = 75 to 500 psi (5 to 35 bar)
- 090 = 75 to 900 psi (5 to 60 bar)
- 180 = 75 to 1800 psi (5 to 125 bar)
- 330 = 75 to 3300 psi (5 to 230 bar)
- 500 = 75 to 5000 psi (5 to 350 bar)

Adjustment Options

- F = Factory pre-set, non-adjustable
(must specify setting below)
- H = Knurled Hand Knob
- K = Allen Head (HEX 5/32") w/ cover cap
- V = Allen Head (HEX 5/32")

Setting (optional)

- (omit) = Set at min. pressure for the range
- XXX = Desired psi ÷ 10

Example: 100 = 1000 psi

Adjustment Options

'V' - Allen Head (std)

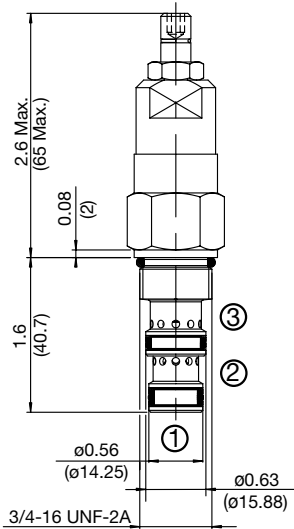

'H' - Hand Knob

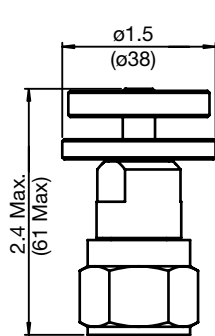

'K' - Protective Cap

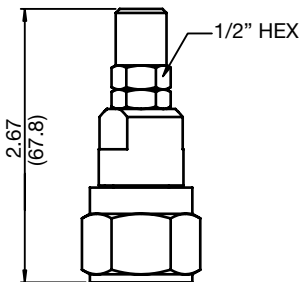

'F' - Tamper Proof Cap

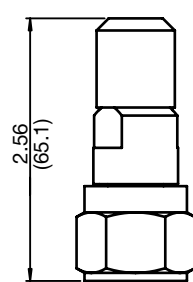

All measurements in inches (mm).
Subject to technical modifications

Standard Line Bodies*

Code	Part No	Material	Pressure Rating	Weight
FH083-AS6	03011424	Aluminum, anodized	3500 psi (245 bar)	0.58 lb (0.26 kg)
FH083-SS6	00560920	Steel, Zinc plated	6000 psi (420 bar)	1.70 lb (0.77 kg)

*Please refer to Line Bodies & Cavities section for details

PRESSURE CONTROL VALVES

DR10P-01

Pressure Reducing/Relieving, Pilot Operated, Spool Type

Up to 26 gpm (100 l/min) • 5000 psi (350 bar)

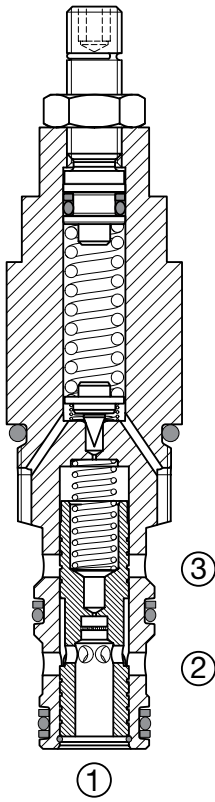
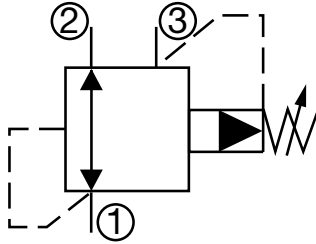

Description

A screw-in cartridge, pilot operated, spool type, pressure reducing/relieving valve with internal pilot and internal spring chamber drain, intended for use as a pressure regulating device for secondary circuits. This valve maintains a secondary regulated/reduced pressure regardless of pressure variations in the primary system. In addition to the reducing function, this valve also provides a relief function from the reduced pressure port to the tank port, if pressure in the secondary circuit exceeds the set pressure.

Operation

The DR10P-01 allows bidirectional flow between port 2 and port 1 with the spring chamber drained through port 3. Once the pressure setting is reached at port 1, the spool shifts to restrict the flow at port 2, thereby regulating pressure at port 1. If pressure at port 1 exceeds the setting of the valve, the spool will shift further and relieve excess pressure through port 3. Any pressure at port 3 is additive to spring set pressure.

Features

- Spring ranges up to 5000 psi (350 bar)
- Positive stop prevents spring from over adjustment (options V,H)
- Adjustable under full pressure
- One-piece body maximizes reliability and minimizes the effect of eccentricity
- Screen protected control orifice to enhance safety
- Fast response with excellent stability
- All external surfaces zinc-plated
- Hardened spool & pilot poppet to ensure minimal wear & extend service life
- Industry common cavity

Specifications

Operating Pressure	5000 psi (350 bar)
Nominal Flow	26 gpm (100 l/min)
Optional Pressure Ranges	90 to 500 psi (6 to 35 bar) 90 to 900 psi (6 to 60 bar) 90 to 1800 psi (6 to 125 bar) 90 to 3300 psi (6 to 230 bar) 90 to 5000 psi (6 to 350 bar)
% of Spring Pressure Range Actuated at 1 Revolution (Adjustment Type V, H)	24%
Fluid Operating Temp. Range	-4° to 248°F (-20° to +120°C) (Consult factory for usage at temp. outside range.)
Fluid Compatibility	Mineral-based or synthetics with lubricating properties
Viscosity	50 to 2000 SUS (7.4 to 420 cSt)
Filtration	21/19/16 or cleaner (per ISO 4406). Use with filter rated $\beta_{10} \geq 200$.
Installation	No orientation restrictions
Cavity	FC10-3 (see Line Bodies & Cavities section)
Cavity Tools	Rougher: 02580092 Finisher: 02580093
Cartridge Weight	0.44 Lbs. (0.203 kg)
Cartridge Material	Steel with hardened work surfaces. Zinc-plated exposed surfaces. Anodized aluminum knobs. (option H) Buna N or Viton® o-rings, and PTFE back-up rings.
Seal Kits	Buna-N P/N: 03071274 Viton® P/N: 03049443

Performance

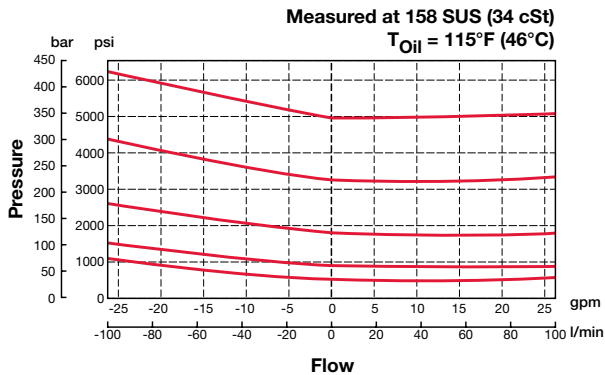

Dimensions

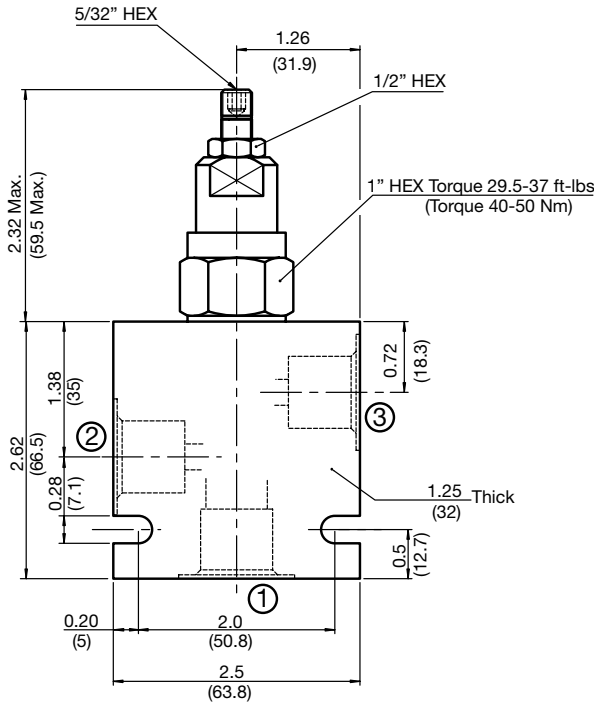

Model Code

DR10P-01-C-N-180 V 100

Valve Model

Body & Ports

- C = Cartridge only
- AS8 = SAE-8 ports, aluminum body
- SS8 = SAE-8 ports, steel body

Seals

- N = Buna-N
- V = Viton®

Adjustment Range

- 050 = 90 to 500 psi (6 to 35 bar)
- 090 = 90 to 900 psi (6 to 60 bar)
- 180 = 90 to 1800 psi (6 to 125 bar)
- 330 = 90 to 3300 psi (6 to 230 bar)
- 500 = 90 to 5000 psi (6 to 350 bar)

Adjustment Options

- F = Factory pre-set, non-adjustable
(must specify setting below)
- H = Knurled Hand Knob
- K = Allen Head (HEX 5/32") w/ cover cap
- V = Allen Head (HEX 5/32")

Setting *(optional)*

- (omit)* = Set at min. pressure for the range
- XXX = Desired psi ÷ 10

Example: 100 = 1000 psi

Adjustment Options

'V' - Allen Head (std)

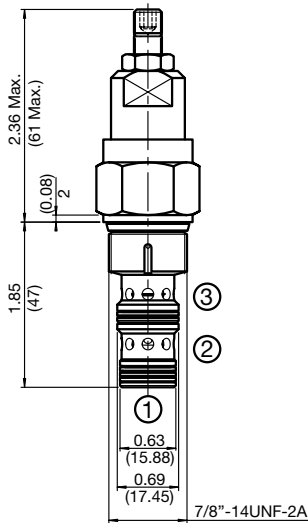

'H' - Hand Knob

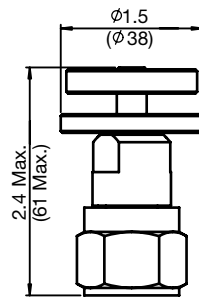

'K' - Protective Cap

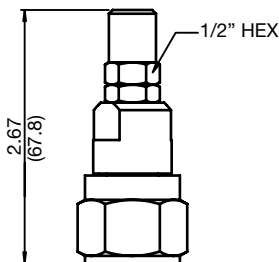

'F' - Tamper Proof Cap

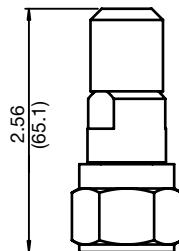

All measurements in inches (mm).
Subject to technical modifications

Standard Line Bodies*

Code	Part No	Material	Pressure Rating	Weight
FH103-AS8	03038095	Aluminum, anodized	3500 psi (245 bar)	0.60 lb (0.27 kg)
FH103-SS8	03037704	Steel, Zinc plated	6000 psi (420 bar)	1.74 lb (0.79 kg)

*Please refer to Line Bodies & Cavities section for details

PRESSURE CONTROL VALVES

Notes



C1 Overview

HYDAC offers a wide range of Flow Control Cartridge Valves:

Adjustable Flow Controls with and without free reverse flow check feature positive shut-off, 6000 psi (420 bar) operating pressure, hand knob and protective cap adjustment options. Models are available for flows up to 42 gpm (160 l/min).

Adjustable, Pressure Compensated Flow Regulators offer flow maintenance with high accuracy, 5000 psi (350 bar) operating pressure. Models are available for flows up to 10 gpm (38 l/min)

Adjustable, Priority Type, Pressure Compensated Flow Regulators offer flow maintenance with high accuracy, 5000 psi (350 bar) operating pressure. Models are available for flows up to 8 gpm (30 l/min).

Flow Divider/Combiner cartridges maintain flow per specified flow ratio regardless of system operating pressure conditions. They are rated to 5000 psi (350 bar) operating pressure. Models are available for flows up to 40 gpm (150 l/min). These valves have a special feature of providing synchronizing flow to either port 4 or port 2 when the other is blocked.

Features

- Variety of adjustment mechanism options
- Zinc-plated external surfaces
- One-piece body to maximize reliability and minimize effect of eccentricity
- Hardened parts to ensure minimal wear and extend service life
- Industry common cavity-compact size

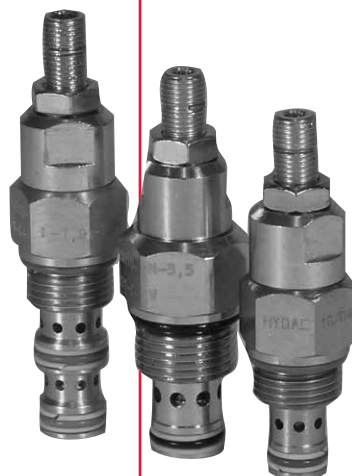

FLOW CONTROL VALVES

SD08-01

Needle, Poppet Type

Up to 16 gpm (60 l/min) • 6000 psi (420 bar)

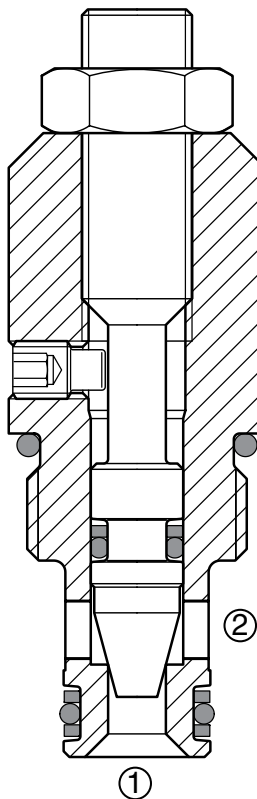
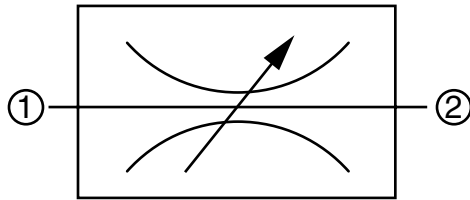

Description

A screw-in cartridge, adjustable variable orifice, hydraulic flow restrictor valve, non-pressure compensated.

Operation

The SD08-01 controls flow in either direction from fully open to leaktight shut-off by turning the adjustment feature clock-wise. Flow is non-pressure compensated.

Features

- All external surfaces zinc plated
- Adjustment needle cannot be backed out of the valve
- Complete shut-off
- Desired setting may be locked down
- Hardened parts to ensure minimal wear and extend service life
- Aluminum knob option for ease of adjustment
- Industry common cavity

Specifications

Operating Pressure	6000 psi (420 bar)
Nominal Flow	16 gpm (60 l/min)
Adjustment Torque Required	1.25 lbf.ft at 3000 psi (1.7Nm at 210 bar) 2.21lbf.ft at 5000 psi (3.0 Nm at 350 bar)
Fluid Operating Temp. Range	-4° to 248°F (-20° to +120°C) <i>(Consult factory for usage at temp. outside range.)</i>
Fluid Compatibility	Mineral-based or synthetics with lubricating properties
Viscosity	50 to 2000 SUS (7.4 to 420 cSt)
Filtration	21/19/16 or cleaner (per ISO 4406). Use with filter rated $\beta_{10} \geq 200$.
Installation	No orientation restrictions
Cavity	FC08-2 (see <i>Line Bodies & Cavities</i> section)
Cavity Tools	Rougher: 02580090 Finisher: 02580091
Cartridge Weight	0.25 Lbs. (0.112 kg)
Cartridge Material	Steel with hardened work surfaces. Zinc-plated exposed surfaces. Anodized aluminum knobs. <i>(option H)</i> Buna N or Viton® o-rings, and PTFE back-up rings.
Seal Kits	Buna-N P/N: 03033920 Viton® P/N: 03051756

Performance

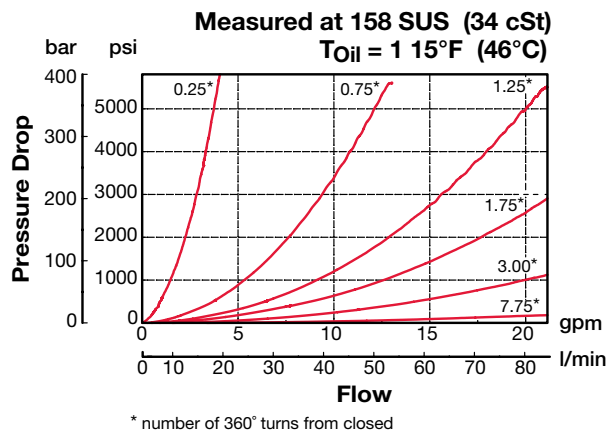

Dimensions

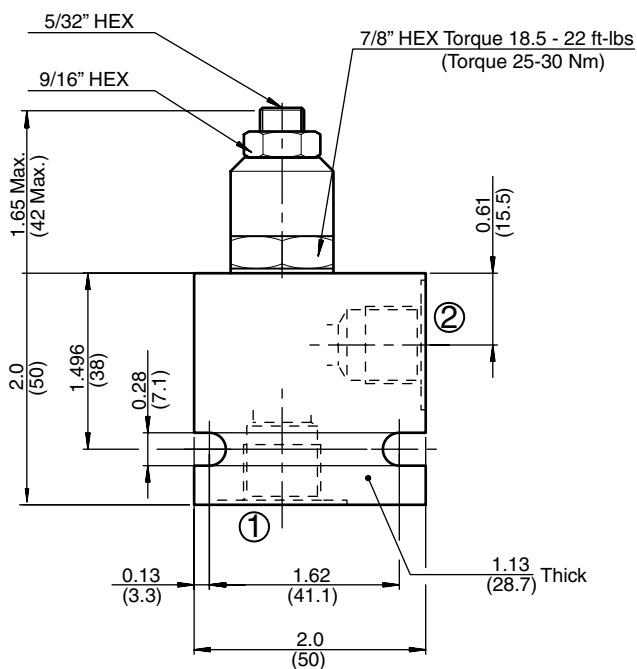

Model Code

SD08-01-C-N-V

- Valve Model** _____
- Body & Ports**
- C = No Line Body, cartridge only
 - AS6 = SAE-6 ports, aluminum body
 - SS6 = SAE-6 ports, steel body
- Seals**
- N = Buna-N
 - V = Viton®
- Adjustment Options**
- H = Knurled Hand Knob
 - K = Allen Head (HEX 5/32") w/ cover cap
 - V = Allen Head (HEX 5/32")

Adjustment Options

'V' - Allen Head (std)

'H' - Hand Knob

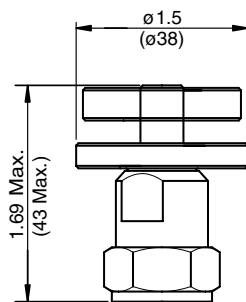
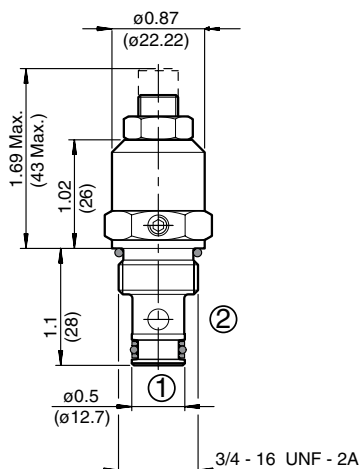

'K' - Protective Cap

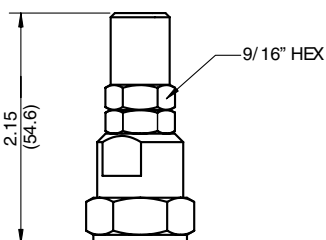

All measurements in inches (mm).
Subject to technical modifications

Standard Line Bodies*

Code	Part No	Material	Pressure Rating	Weight
FH082-AS6	03011409	Aluminum, anodized	3500 psi (245 bar)	0.34 lb (0.15 kg)
FH082-SS6	00560917	Steel, Zinc plated	6000 psi (420 bar)	1.00 lb (0.45 kg)

*Please refer to Line Bodies & Cavities section for details

FLOW CONTROL VALVES

SD10-01

Needle, Poppet Type

Up to 42 gpm (160 l/min) • 6000 psi (420 bar)

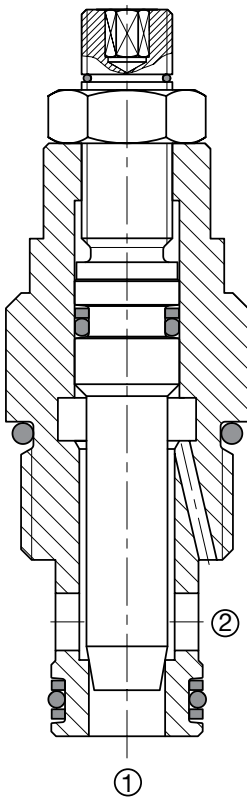
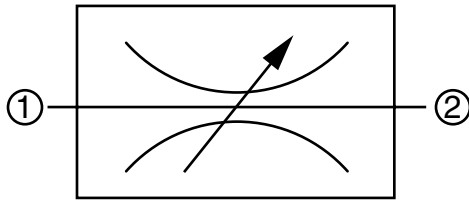

Description

A screw-in cartridge, adjustable variable orifice, hydraulic flow restrictor valve, non-pressure compensated.

Operation

The SD10-01 controls flow in either direction from fully open to leaktight shut-off by turning the adjustment feature clock-wise. Flow is non-pressure compensated.

Features

- Adjustment needle cannot be backed out of the valve
- Desired setting may be locked down
- Aluminum knob option for ease of adjustment
- Complete shut-off
- Hardened parts to ensure minimal wear and extend service life
- All external surfaces zinc-plated
- Industry common cavity

Specifications

Operating Pressure	6000 psi (420 bar)
Nominal Flow	42 gpm (160 l/min)
Adjustment Torque Required	1.25 lbf.ft at 3000 psi (1.7 Nm at 210 bar) 2.21 lbf.ft at 5000 psi (3.0 Nm at 350 bar)
Fluid Operating Temp. Range	-4° to 248°F (-20° to +120°C) <i>(Consult factory for usage at temp. outside range.)</i>
Fluid Compatibility	Mineral-based or synthetics with lubricating properties
Viscosity	50 to 2000 SUS (7.4 to 420 cSt)
Filtration	21/19/16 or cleaner (per ISO 4406). Use with filter rated $\beta_{10} \geq 200$.
Installation	No orientation restrictions
Cavity	FC10-2 (see <i>Line Bodies & Cavities</i> section)
Cavity Tools	Rougher: 02580274 Finisher: 02580274
Cartridge Weight	0.35 Lbs. (0.160 kg)
Cartridge Material	Steel with hardened work surfaces. Zinc-plated exposed surfaces. Anodized aluminum knobs. <i>(option H)</i> Buna N or Viton® o-rings, and PTFE back-up rings.
Seal Kits	Buna-N P/N: 03033872 Viton® P/N: 03051757

Performance

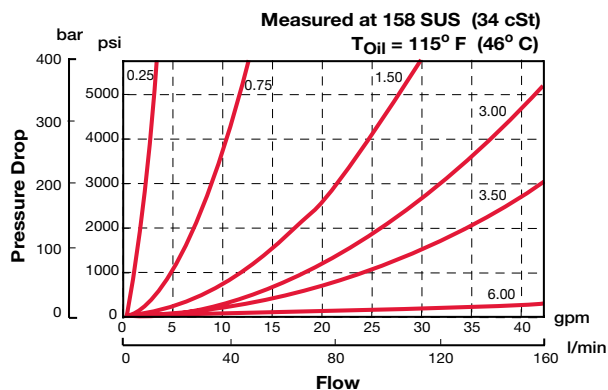

Dimensions

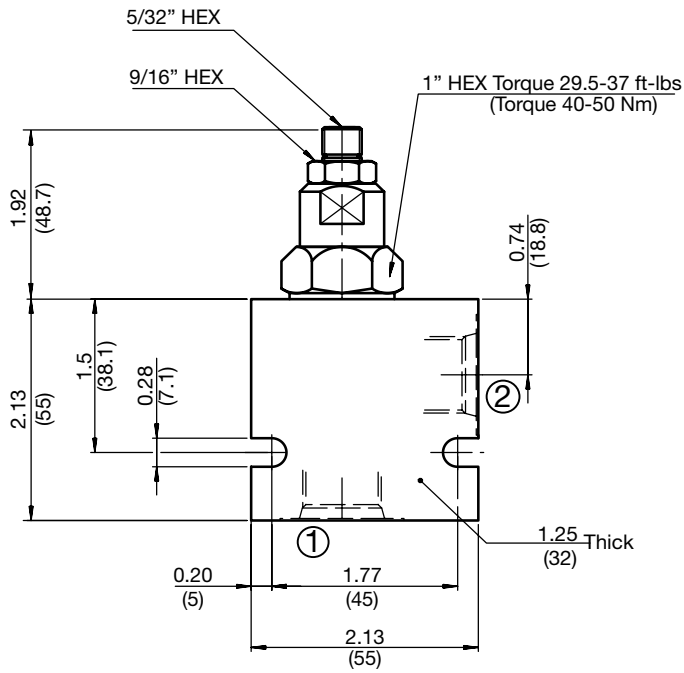

Model Code

SD10-01-C-N-V

Valve Model

Body & Ports

- C = No Line Body, cartridge only
- AS8 = SAE-8 ports, aluminum body
- SS8 = SAE-8 ports, steel body

Seals

- N = Buna-N
- V = Viton®

Adjustment Options

- H = Knurled Hand Knob
- K = Allen Head (HEX 5/32") w/ cover cap
- V = Allen Head (HEX 5/32")

Adjustment Options

'V' - Allen Head (std)

'H' - Hand Knob

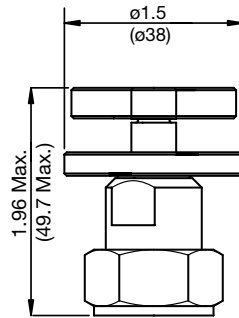
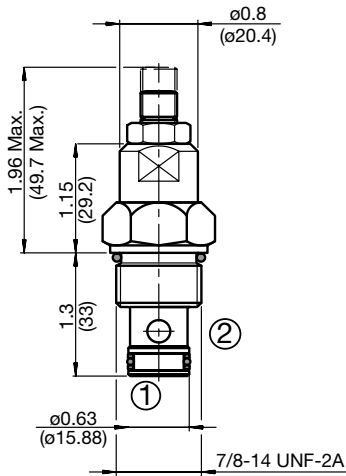

'K' - Protective Cap

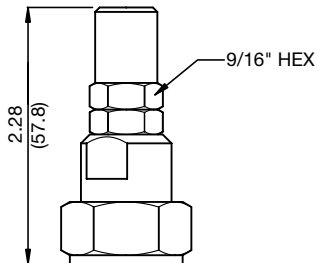

All measurements in inches (mm).
Subject to technical modifications

Standard Line Bodies*

Code	Part No	Material	Pressure Rating	Weight
FH102-AS8	03037778	Aluminum, anodized	3500 psi (245 bar)	0.34 lb (0.15 kg)
FH102-SS8	03037612	Steel, Zinc plated	6000 psi (420 bar)	1.00 lb (0.45 kg)

*Please refer to Line Bodies & Cavities section for details

FLOW CONTROL VALVES

SDR10A-01

Needle, Free Reverse Flow

Up to 42 gpm (160 l/min) • 5000 psi (350 bar)

Hydraulic Symbol

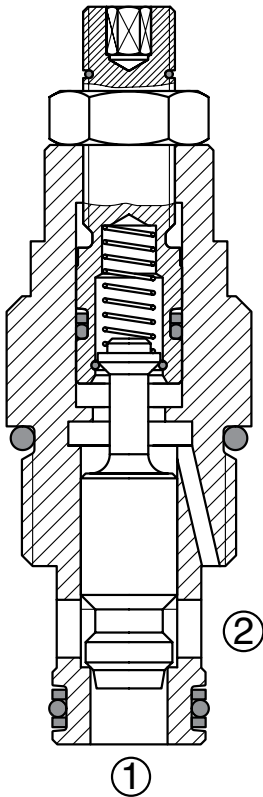
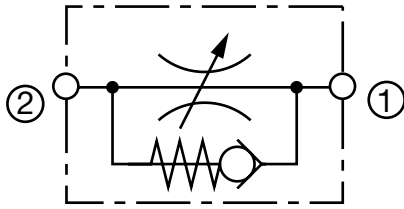

Description

A screw-in cartridge, adjustable variable orifice, hydraulic flow restrictor valve with free reverse flow check, non-pressure compensated.

Operation

The SDR10A-01 controls flow from port 2 to port 1 from fully open to leaktight shut-off by turning the adjustment feature clock-wise. Flow is non-pressure compensated. The flow from port 1 to port 2 is free.

Features

- All external surfaces zinc-plated
- Adjustment needle cannot be backed out of the valve
- Desired setting may be locked down
- Complete shut-off
- Hardened parts to ensure minimal wear and extend service life
- Aluminum knob option for ease of adjustment
- Industry common cavity

Specifications

Operating Pressure	5000 psi (350 bar)
Nominal Flow	42 gpm (160 l/min)
Adjustment Torque Required	1.25 lbf.ft at 3000 psi (1.7 Nm at 210 bar) 2.21 lbf.ft at 5000 psi (3.0 Nm at 350 bar)
Bias Spring Setting	15 psi (1 bar) Minimum
Fluid Operating Temp. Range	-4° to 248°F (-20° to +120°C) <i>(Consult factory for usage at temp. outside range.)</i>
Fluid Compatibility	Mineral-based or synthetics with lubricating properties
Viscosity	50 to 2000 SUS (7.4 to 420 cSt)
Filtration	21/19/16 or cleaner (per ISO 4406). Use with filter rated $\beta_{10} \geq 200$.
Installation	No orientation restrictions
Cavity	FC10-2 (see <i>Line Bodies & Cavities</i> section)
Cavity Tools	Rougher: 02580274 Finisher: 02580274
Cartridge Weight	0.33 Lbs. (0.150 kg)
Cartridge Material	Steel with hardened work surfaces. Zinc-plated exposed surfaces. Anodized aluminum knobs. <i>(option H)</i> Buna N or Viton® o-rings, and PTFE back-up rings.
Seal Kits	Buna-N P/N: 03033872 Viton® P/N: 03051757

Performance

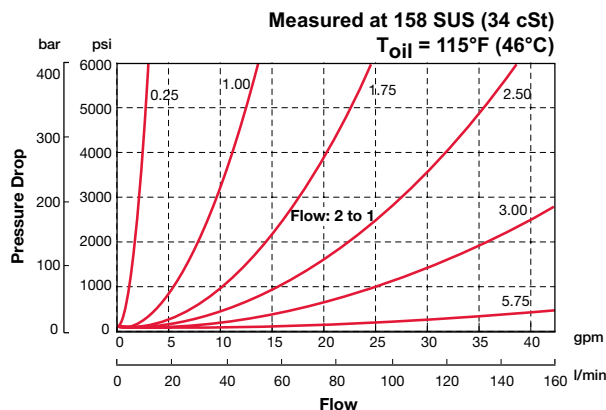

Dimensions

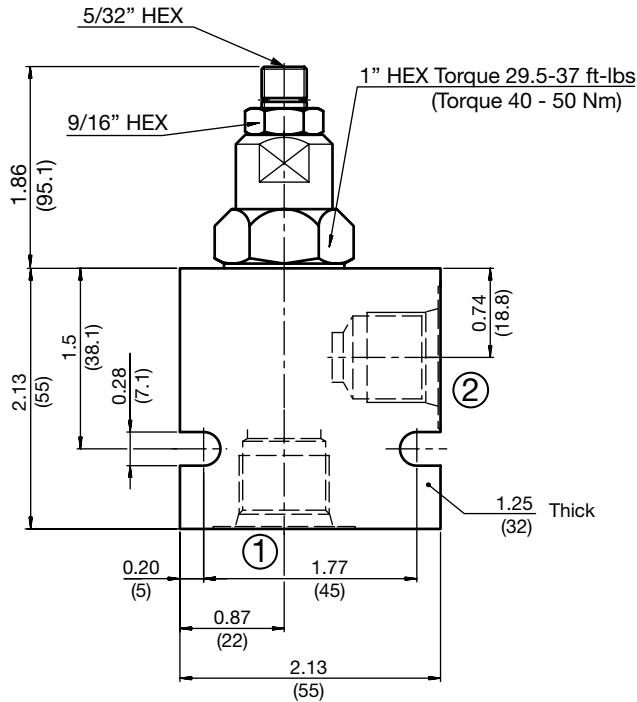

Adjustment Options

'V' - Allen Head (std)

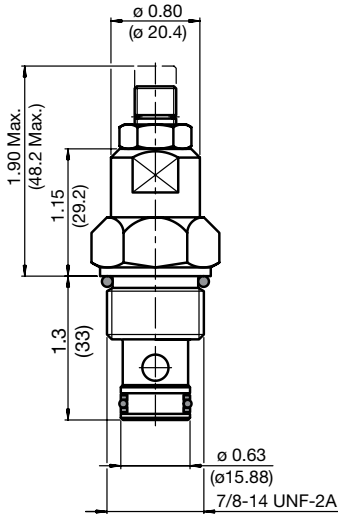

'H' - Hand Knob

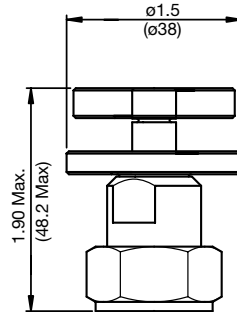

'K' - Protective Cap

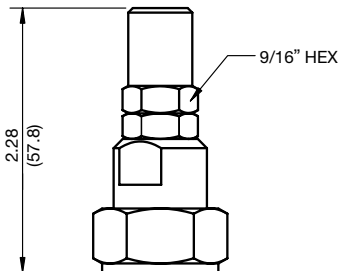

All measurements in inches (mm).
Subject to technical modifications

Model Code

SDR10A-01-C-N-15-V

Valve Model

Body & Ports

- C = Cartridge only
- AS8 = SAE-8 ports, aluminum body
- SS8 = SAE-8 ports, steel body

Seals

- N = Buna-N
- V = Viton®

Bias Spring

- 15 = 15 psi (1.00 bar)

Adjustment Options

- H = Knurled Hand Knob
- K = Allen Head (HEX 5/32") w/ cover cap
- V = Allen Head (HEX 5/32")

Performance

Measured at 158 SUS (34 cSt)
T_{oil} = 115°F (46°C)

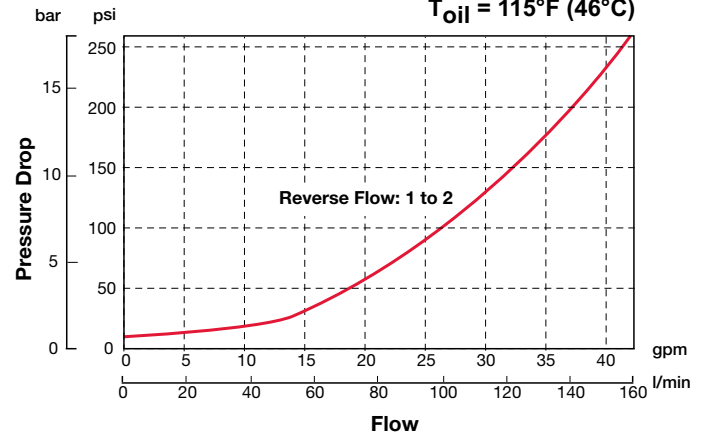

Standard Line Bodies*

Code	Part No	Material	Pressure Rating	Weight
FH102-AS8	03037778	Aluminum, anodized	3500 psi (245 bar)	0.40 lb (0.18 kg)
FH102-SS8	03037612	Steel, Zinc plated	6000 psi (420 bar)	1.16 lb (0.53 kg)

*Please refer to Line Bodies & Cavities section for details

FLOW CONTROL VALVES

SR06-01

Flow Regulator, Pressure Compensated, Restrictive Type

Up to 4 gpm (15 l/min) • 5000 psi (350 bar)

Hydraulic Symbol

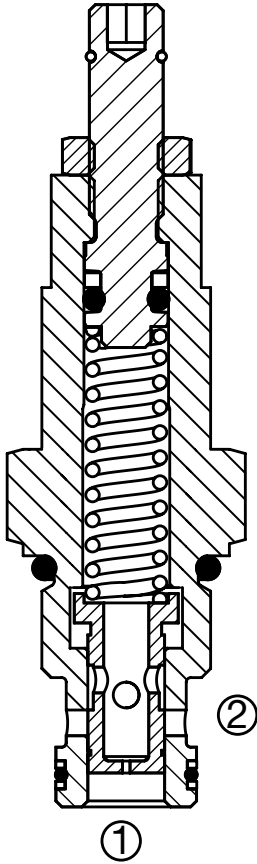
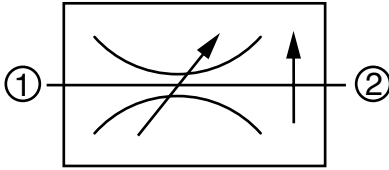

Description

A screw-in cartridge, adjustable, pressure compensated, hydraulic flow regulating valve (*restrictive type*).

Operation

The SR06-01 maintains a constant flow from port 1 to port 2 based on the setting adjustment, regardless of pressure changes downstream of port 2. The flow rate is determined by a fixed control orifice and could be adjusted within a limited range. Reverse flow from port 2 to port 1 is at the value of the fixed control orifice and is non-pressure compensated.

Features

- Excellent stability throughout flow range
- Desired setting may be locked down
- Adjustment screw cannot be backed out of the valve
- All external surfaces zinc-plated
- Hardened parts to ensure minimal wear and extend service life

Specifications

Operating Pressure	5000 psi (350 bar)
Max. Operating Pressure, Port 2	3000 psi (210 bar)
Maximum Flow	4 gpm (15.2 l/min)
Flow Ranges	0.3 = 0.06 - 0.25 gpm (0.23 - 0.95 l/min) 1.0 = 0.25 - 1.0 gpm (0.95 - 3.78 l/min) 4.0 = 1.0 - 4.0 gpm (3.78 - 15.14 l/min)
Fluid Compatibility	Mineral-Based or Synthetics with lubricating properties
Viscosity	50 to 2000 SUS (7.4 to 420 cSt)
Filtration	21/19/16 or cleaner per (ISO 4406)
Installation	No orientation restrictions
Cavity	FC06-2 (see <i>Line Bodies & Cavities</i> section)
Cavity Tools	Rougher: 02582046 Finisher: 02582047
Cartridge Weight	0.05 lb (23 g)
Cartridge Material	Steel with hardened work surfaces. Zinc plated exposed surfaces. Buna N or Viton® o-rings. Solid thermoplastic polyester back-up rings.
Seal Kits	Buna-N P/N: 02610184 Viton® P/N: 02610185

Performance

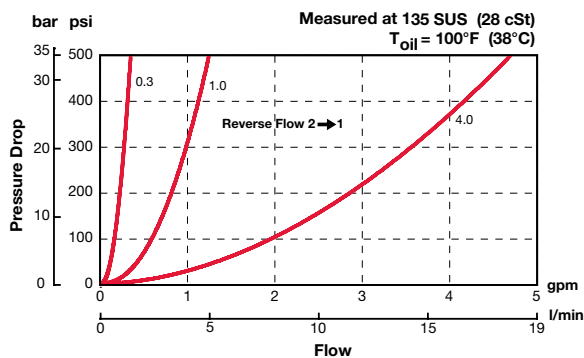

Dimensions

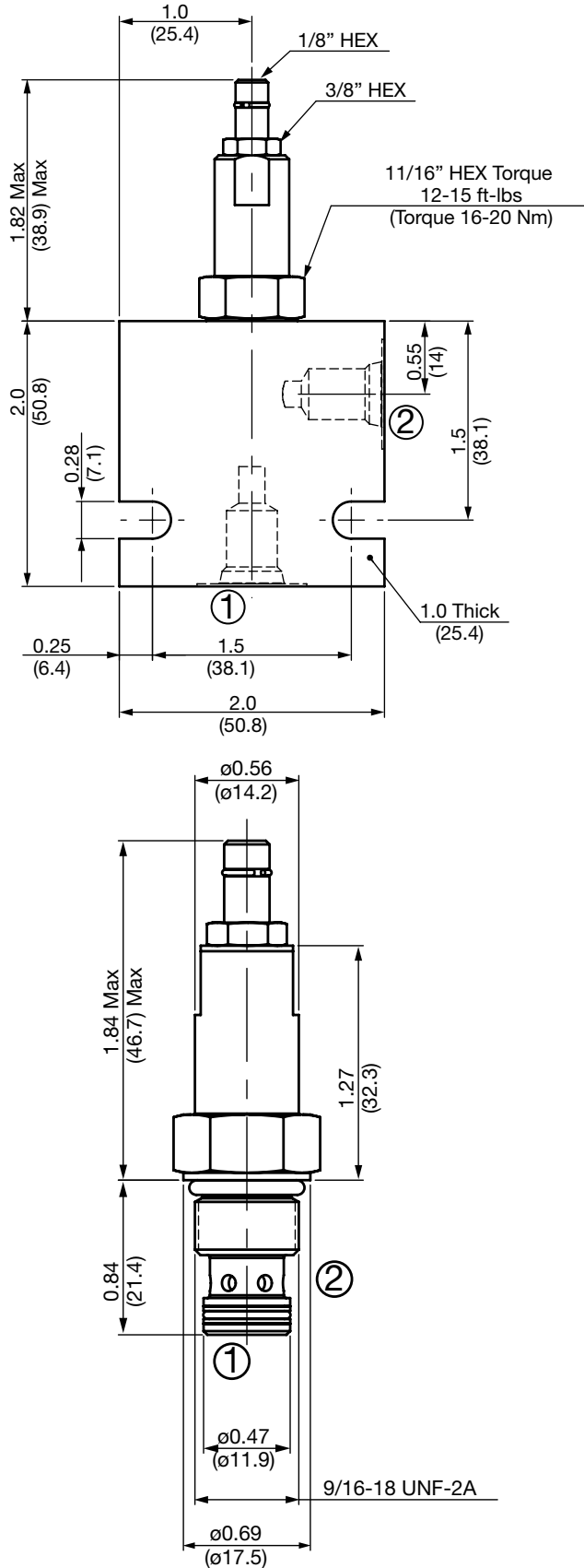

All measurements in inches (mm).
Subject to technical modifications

Model Code

SR06-01-AS4-N-1.0 V 0.8

- Valve Model** _____
- Body & Ports** _____
- C = Cartridge only
 - AS4 = SAE-4 Ports, aluminum Body
 - SS4 = SAE-4 Ports, steel Body
- Seals** _____
- N = Buna-N
 - V = Viton®
- Flow Rate** _____
- 0.3 = 0.06 to 0.25 gpm (0.23 to 0.95 l/pm)
 - 1.0 = 0.25 to 1.0 gpm (0.95 to 3.78 l/pm)
 - 4.0 = 1.0 to 4.0 gpm (3.78 to 15.14 l/pm)
- Adjustment Options** _____
- V = Allen Head (Hex 1/8")
- Setting** _____
- blank = Set at 50% of maximum flow for the range
 - xxx = flow rate in gpm
- Example: 0.8 = 0.8 gpm*

Performance

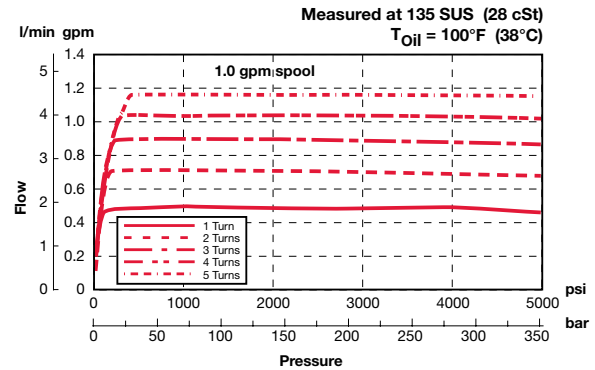
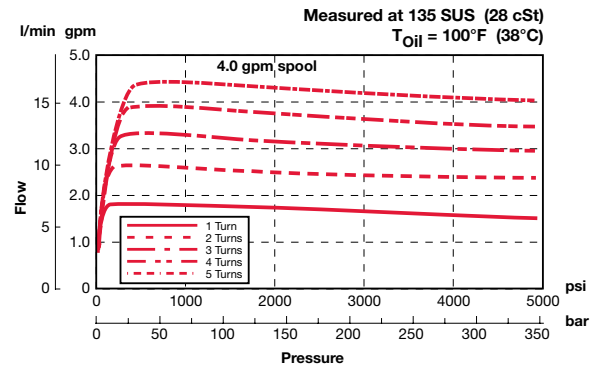

Standard Line Bodies*

Code	Part No	Material	Pressure Rating	Weight
FH062-AS4	02600491	Aluminum, anodized	3500 psi (245 bar)	0.34 lbs (0.15 kg)
FH062-SS4	02600490	Steel, Zinc plated	6000 psi (420 bar)	1.0 lbs (0.45 kg)

*Please refer to Line Bodies & Cavities section for details

FLOW CONTROL VALVES

SR08-01

Flow Regulator, Pressure Compensated, Restrictive Type

Up to 7 gpm (27 l/min) • 6000 psi (420 bar)

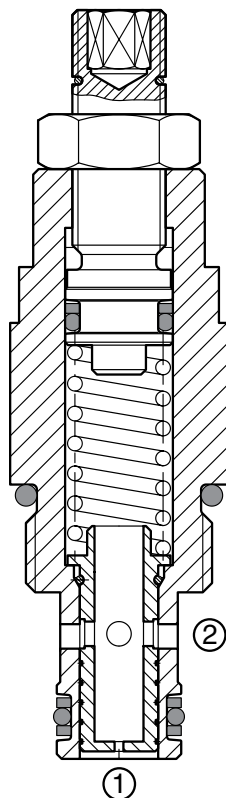
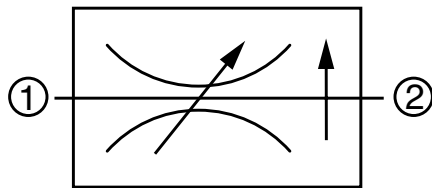

Description

A screw-in cartridge, adjustable, pressure compensated, hydraulic flow regulating valve (restrictive type).

Operation

The SR08-01 maintains a constant flow from port 1 to port 2 based on the setting adjustment, regardless of pressure changes downstream of port 2. The flow rate is determined by a fixed control orifice and could be adjusted within a limited range. Reverse flow from port 2 to port 1 is at the value of the fixed control orifice and is non-pressure compensated.

Features

- All external surfaces zinc plated
- Adjustment screw cannot be backed out of the valve
- Excellent stability throughout flow range
- Reverse flow capability
- Desired setting may be locked down
- Hardened parts to ensure minimal wear and extend service life
- One-piece body maximizes reliability and minimizes the effect of eccentricity
- Aluminum knob option for ease of adjustment
- Industry common cavity

Specifications

Operating Pressure	6000 psi (420 bar)
Max. Operating Pressure, Port 2	3000 psi (210 bar)
Nominal Flow	7 gpm (27 l/min)
Adjustment Torque Required	1.25 lbf.ft at 3000 psi (1.7Nm at 210 bar) 2.21lbf.ft at 5000 psi (3.0 Nm at 350 bar)
Flow Ranges	0.25 - 0.40 gpm (0.95 - 1.50 l/min) 0.30 - 0.53 gpm (1.15 - 2.00 l/min) 0.53 - 0.95 gpm (2.00 - 3.60 l/min) 0.87 - 1.66 gpm (3.30 - 6.30 l/min) 1.42 - 2.55 gpm (5.40 - 9.70 l/min) 2.30 - 4.40 gpm (8.80 - 16.7 l/min) 3.70 - 7.10 gpm (14.0 - 27.0 l/min)
Fluid Operating Temp. Range	-4° to 248°F (-20° to +120°C) <i>(Consult factory for usage at temp. outside range.)</i>
Fluid Compatibility	Mineral-based or synthetics with lubricating properties
Viscosity	50 to 2000 SUS (7.4 to 420 cSt)
Filtration	21/19/16 or cleaner (per ISO 4406). Use with filter rated $\beta_{10} \geq 200$.
Installation	No orientation restrictions
Cavity	FC08-2 (see <i>Line Bodies & Cavities</i> section)
Cavity Tools	Rougher: 02580090 Finisher: 02580091
Cartridge Weight	0.25 Lbs. (0.112 kg)
Cartridge Material	Steel with hardened work surfaces. Zinc-plated exposed surfaces. Anodized aluminum knobs. <i>(option H)</i> Buna N or Viton® o-rings, and PTFE back-up rings.
Seal Kits	Buna-N P/N: 03033920 Viton® P/N: 03051756

Performance

Measured at 158 SUS (34 cSt)
 $T_{oil} = 115^{\circ}F (46^{\circ}C)$

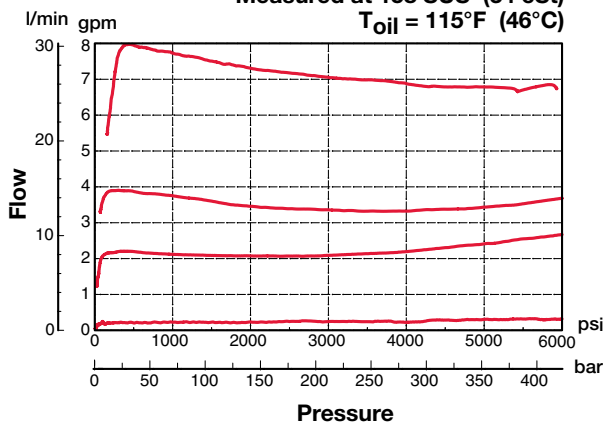

Dimensions

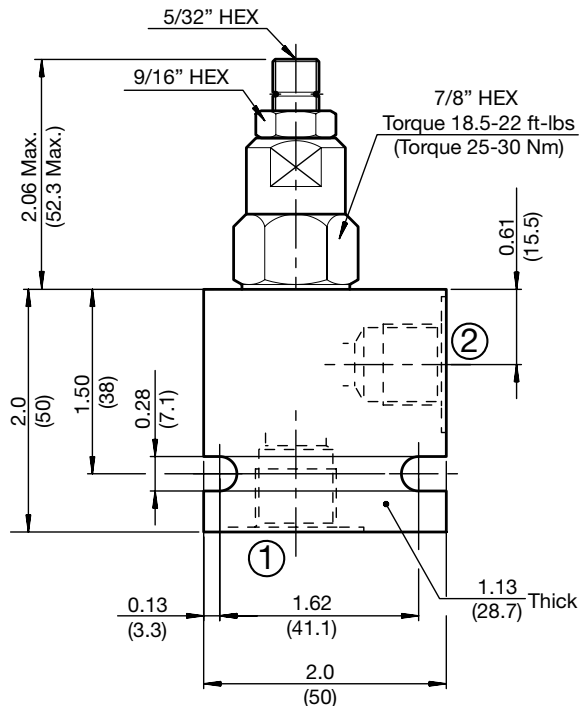

Model Code

SR08-01-C-N-1.0 V 0.8

Valve Model

Body & Ports

- C = Cartridge only
- AS6 = SAE-6 ports, aluminum body
- SS6 = SAE-6 ports, steel body

Seals

- N = Buna-N
- V = Viton®

Flow Rate

- 0.5 = 0.25 - 0.40 gpm (0.95 - 1.50 l/min)
- 0.6 = 0.30 - 0.53 gpm (1.15 - 2.00 l/min)
- 1.0 = 0.53 - 0.95 gpm (2.00 - 3.60 l/min)
- 1.8 = 0.87 - 1.66 gpm (3.30 - 6.30 l/min)
- 2.8 = 1.42 - 2.55 gpm (5.40 - 9.70 l/min)
- 4.8 = 2.30 - 4.40 gpm (8.80 - 16.7 l/min)
- 7.9 = 3.70 - 7.10 gpm (14.0 - 27.0 l/min)

Adjustment Options

- F = Factory pre-set, non-adjustable
(must specify setting below)
- H = Knurled Hand Knob
- K = Allen Head (HEX 5/32") w/ cover cap
- V = Allen Head (HEX 5/32")

Setting

- blank = Set at 50% of maximum flow for the range
- xxx = flow rate in gpm

Example: 0.8 = 0.8 psi

Adjustment Options

'V' - Allen Head (std)

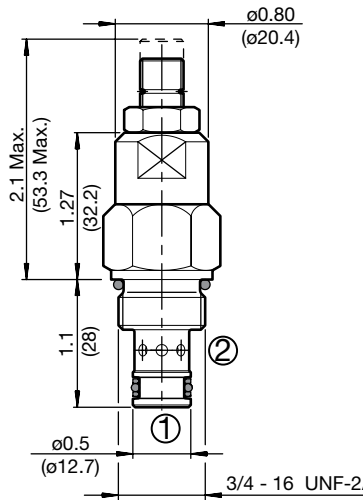

'H' - Hand Knob

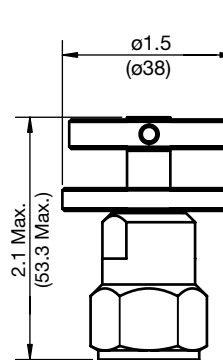

'K' - Protective Cap

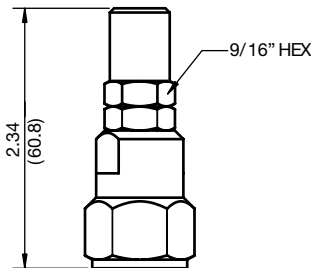

'F' - Tamper Proof Cap

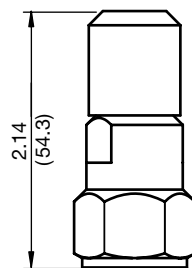

Performance

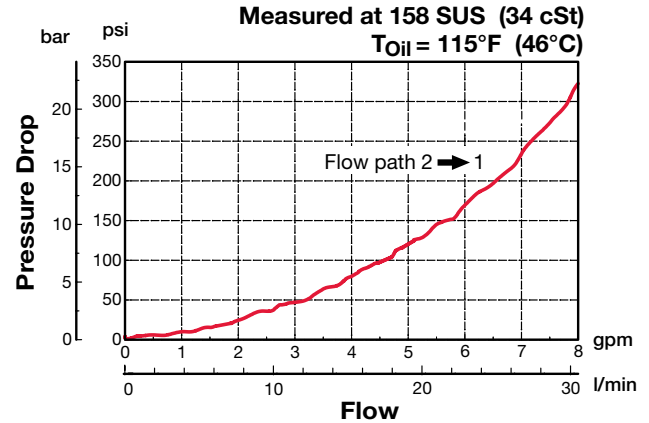

All measurements in inches (mm).
Subject to technical modifications

Standard Line Bodies*

Code	Part No	Material	Pressure Rating	Weight
FH082-AS6	03011409	Aluminum, anodized	3500 psi (245 bar)	0.34 lb (0.15 kg)
FH082-SS6	00560917	Steel, Zinc plated	6000 psi (420 bar)	1.00 lb (0.45 kg)

*Please refer to Line Bodies & Cavities section for details

FLOW CONTROL VALVES

SR10-01

Flow Regulator, Pressure Compensated, Restrictive Type

Up to 10 gpm (38 l/min) • 5000 psi (350 bar)

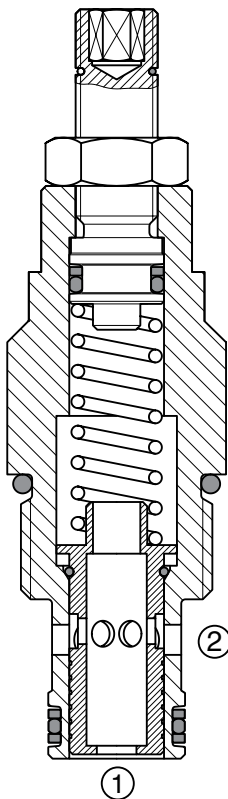
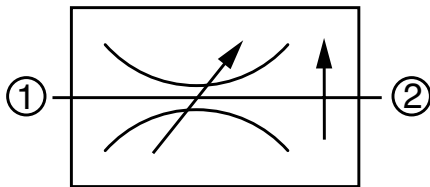

Description

A screw-in cartridge, adjustable, pressure compensated, hydraulic flow regulating valve (restrictive type).

Operation

The SR10-01 maintains a constant flow from port 1 to port 2 based on the setting adjustment, regardless of pressure changes downstream of port 2. The flow rate is determined by a fixed control orifice and could be adjusted within a limited range. Reverse flow from port 2 to port 1 is at the value of the fixed control orifice and is non-pressure compensated.

Features

- Excellent stability throughout flow range
- Reverse flow capability
- Desired setting may be locked down
- Adjustment screw cannot be backed out of the valve
- All external surfaces zinc-plated
- Aluminum knob option for ease of adjustment
- Hardened parts to ensure minimal wear and extend service life
- One-piece body maximizes reliability and minimizes the effect of eccentricity
- Industry common cavity

Specifications

Operating Pressure	5000 psi (350 bar)
Max. Operating Pressure, Port 2	3000 psi (210 bar)
Nominal Flow	10 gpm (38 l/min)
Adjustment Torque Required	1.25 lbf.ft at 3000 psi (1.7Nm at 210 bar) 2.21lbf.ft at 5000 psi (3.0 Nm at 350 bar)
Flow Ranges and Accuracy	1.0 - 3.5 gpm (4 - 13 l/min) ±10% 3.5 - 10.0 gpm (13 - 38 l/min) ±10%
Fluid Operating Temp. Range	-4° to 248°F (-20° to +120°C) (Consult factory for usage at temp. outside range.)
Fluid Compatibility	Mineral-based or synthetics with lubricating properties
Viscosity	50 to 2000 SUS (7.4 to 420 cSt)
Filtration	21/19/16 or cleaner (per ISO 4406). Use with filter rated $\beta_{10} \geq 200$.
Installation	No orientation restrictions
Cavity	FC10-2 (see <i>Line Bodies & Cavities</i> section)
Cavity Tools	Rougher: 02580274 Finisher: 02580247
Cartridge Weight	0.35 Lbs. (0.16 kg)
Cartridge Material	Steel with hardened work surfaces. Zinc-plated exposed surfaces. Anodized aluminum knobs. (option H) Buna N or Viton® o-rings, and PTFE back-up rings.
Seal Kits	Buna-N P/N: 03033872 Viton® P/N: 03051757

Performance

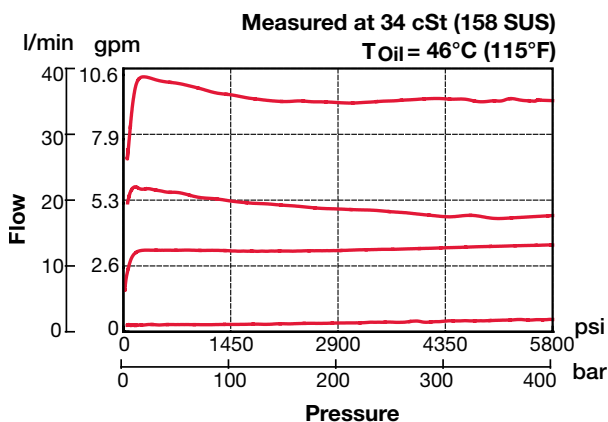

Dimensions

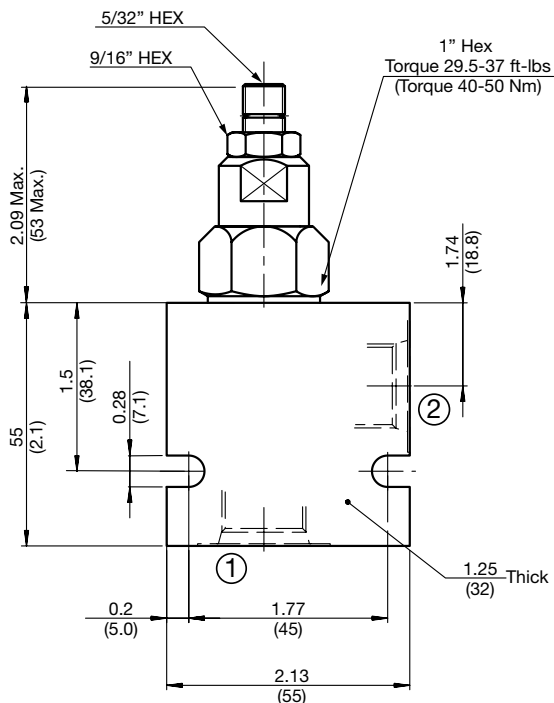

Adjustment Options

'V' - Allen Head (std)

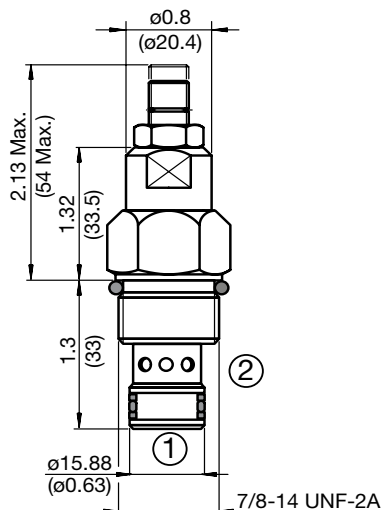

'H' - Hand Knob

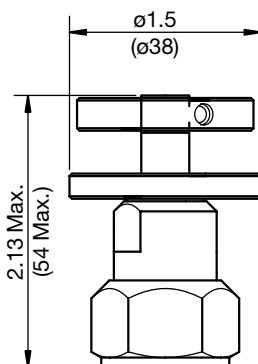

'K' - Protective Cap

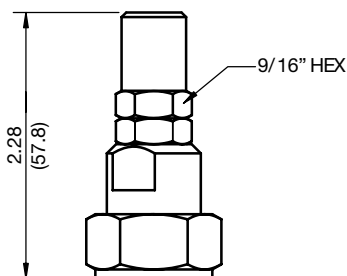

'F' - Tamper Proof Cap

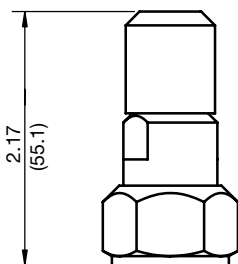

All measurements in inches (mm).
Subject to technical modifications

Model Code

SR10-01-C-N-3.5 V 1.8

Valve Model

Body & Ports

- C = Cartridge only
- AS8 = SAE-8 ports, aluminum body
- SS8 = SAE-8 ports, steel body

Seals

- N = Buna-N
- V = Viton®

Flow Rate

- 3.5 = 1.0 to 3.5 gpm (4 to 13 l/min)
- 10.0 = 3.5 to 10.0 gpm (13 to 38 l/min)

Adjustment Options

- F = Factory pre-set, non-adjustable
(must specify setting below)
- H = Knurled Hand Knob
- K = Allen Head (HEX 5/32") w/ cover cap
- V = Allen Head (HEX 5/32")

Setting

- blank = Set at 50% of maximum flow for the range
- xxx = flow rate in gpm

Example: 1.8 = 1.8 psi

Performance

Measured at 34 cSt (158 SUS)

T_{Oil} = 46°C (115°F)

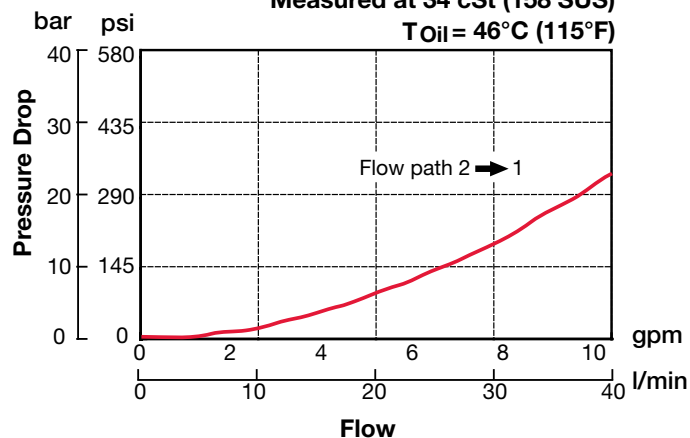

Standard Line Bodies*

Code	Part No	Material	Pressure Rating	Weight
FH102-AS8	03037778	Aluminum, anodized	3500 psi (245 bar)	0.40 lb (0.18 kg)
FH102-SS8	03037612	Steel, Zinc plated	6000 psi (420 bar)	1.16 lb (0.53 kg)

*Please refer to Line Bodies & Cavities section for details

FLOW CONTROL VALVES

SRP08-01

Flow Regulator, Pressure Compensated, Priority Type

Up to 8 gpm (30 l/min) • 5000 psi (350 bar)

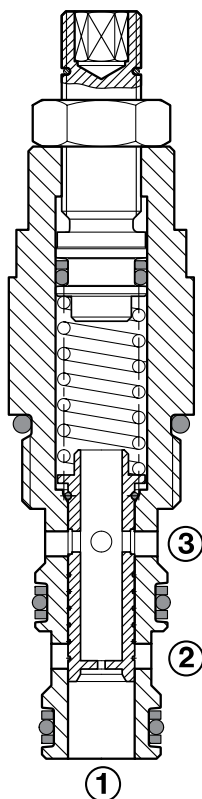
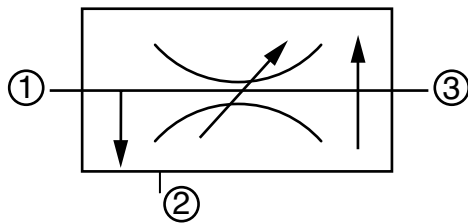

Description

A screw-in cartridge, adjustable, pressure compensated, priority type hydraulic flow regulating valve.

Operation

The SRP08-01 maintains a constant priority flow from port 1 to port 3 based on the setting adjustment, regardless of pressure changes downstream of port 3 or in the bypass line at port 2. The flow rate is determined by a fixed control orifice and could be adjusted within a limited range. Flow in excess of the priority setting is directed to port 2. If the priority flow at port 3 is blocked, the spool will shift, thereby closing off flow to port 2.

Features

- Excellent stability throughout flow range
- Reverse flow capability
- Desired setting may be locked down
- Adjustment screw cannot be backed out of the valve
- Bypass port 2 may be fully pressurized
- All external surfaces zinc-plated
- Aluminum knob option for ease of adjustment
- Hardened parts to ensure minimal wear and extend service life
- Industry common cavity

Specifications

Operating Pressure	5000 psi (350 bar)
Nominal Flow	8 gpm (30 l/min)
Flow Ranges	0.34 - 0.47 gpm (1.30 - 1.80 l/min) 0.42 - 0.66 gpm (1.60 - 2.50 l/min) 0.53 - 1.00 gpm (2.00 - 3.70 l/min) 0.92 - 1.70 gpm (3.50 - 6.50 l/min) 1.60 - 3.30 gpm (6.00 - 12.5 l/min) 2.30 - 5.50 gpm (8.80 - 20.8 l/min)
Adjustment Torque Required	1.25 lbf.ft at 3000 psi (1.7Nm at 210 bar) 2.21lbf.ft at 5000 psi (3.0 Nm at 350 bar)
Fluid Operating Temp. Range	-4° to 248°F (-20° to +120°C) <i>(Consult factory for usage at temp. outside range.)</i>
Fluid Compatibility	Mineral-based or synthetics with lubricating properties
Viscosity	50 to 2000 SUS (7.4 to 420 cSt)
Filtration	21/19/16 or cleaner (per ISO 4406). Use with filter rated $\beta_{10} \geq 200$.
Installation	No orientation restrictions
Cavity	FC08-3 (see <i>Line Bodies & Cavities</i> section)
Cavity Tools	Rougher: 02580086 Finisher: 02580087
Cartridge Weight	0.35 Lbs. (0.15 kg)
Cartridge Material	Steel with hardened work surfaces. Zinc-plated exposed surfaces. Anodized aluminum knobs. <i>(option H)</i> Buna N or Viton® o-rings, and PTFE back-up rings.
Seal Kits	Buna-N P/N: 03054795 Viton® P/N: 02591059

Performance

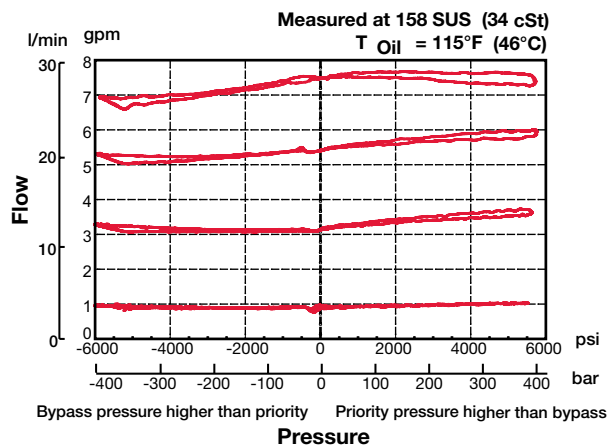

Dimensions

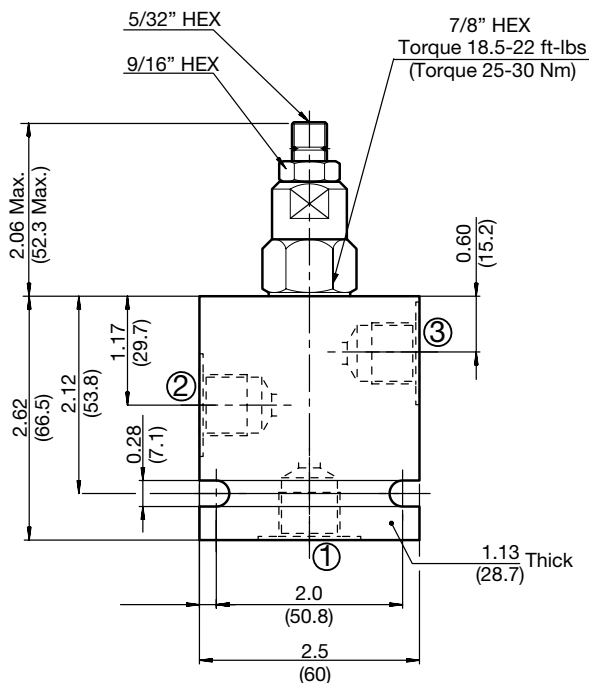

Model Code

SRP08-01-C-N-1.0 V 0.8

Valve Model	_____
Body & Ports	_____
C	= No Line Body, cartridge only
AS6	= SAE-6 ports, aluminum body
SS6	= SAE-6 ports, steel body
Seals	_____
N	= Buna-N
V	= Viton®
Flow Rate	_____
0.5	= 0.34 - 0.47 gpm (1.30 - 1.80 l/min)
0.6	= 0.42 - 0.66 gpm (1.60 - 2.50 l/min)
1.0	= 0.53 - 1.00 gpm (2.00 - 3.70 l/min)
1.6	= 0.92 - 1.70 gpm (3.50 - 6.50 l/min)
3.0	= 1.60 - 3.30 gpm (6.00 - 12.5 l/min)
5.5	= 2.30 - 5.50 gpm (8.80 - 20.8 l/min)
7.9	= 3.60 - 7.90 gpm (13.5 - 30.0 l/min)
Adjustment Options	_____
F	= Factory pre-set, non-adjustable <i>(must specify setting below)</i>
H	= Knurled Hand Knob
K	= Allen Head (HEX 5/32") w/ cover cap
V	= Allen Head (HEX 5/32")
Setting	_____
blank	= Set at 50% of maximum flow for the range
xxx	= flow rate in gpm
<i>Example: 0.8 = 0.8 psi</i>	

Adjustment Options

'V' - Allen Head (std)

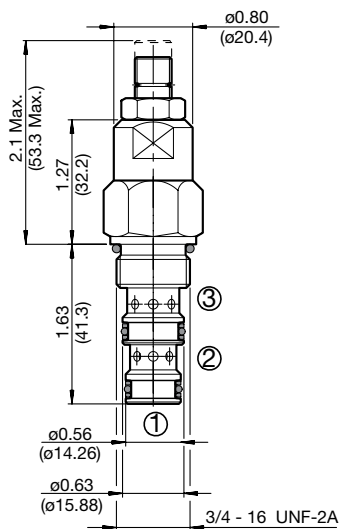

'H' - Hand Knob

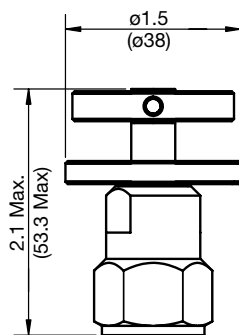

'K' - Protective Cap

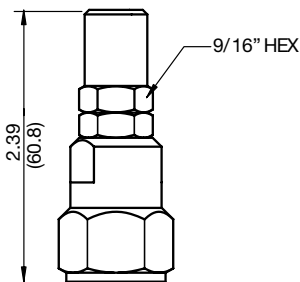

'F' - Tamper Proof Cap

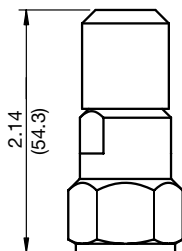

All measurements in inches (mm).
Subject to technical modifications

Standard Line Bodies*

Code	Part No	Material	Pressure Rating	Weight
FH083-AS6	03011424	Aluminum, anodized	3500 psi (245 bar)	0.34 lb (0.15 kg)
FH083-SS6	00560920	Steel, Zinc plated	6000 psi (420 bar)	1.00 lb (0.45 kg)

*Please refer to Line Bodies & Cavities section for details

FLOW CONTROL VALVES

ST10-01

Flow Divider/Combiner, Spool Type

Up to 12 gpm (45 l/min) • 5000 psi (350 bar)

Hydraulic Symbol

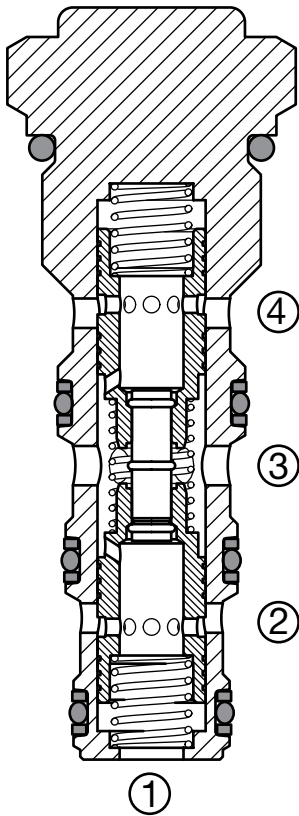
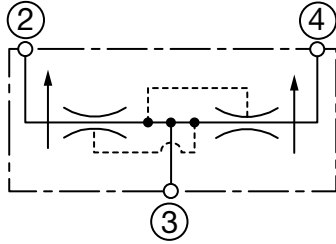

Description

A screw-in cartridge, spool type, pressure compensated flow divider/combiner.

Operation

In the dividing mode, ST10-01 divides the input flow on port 3 between ports 2 and 4, based on the specified ratio, regardless of the operating pressure. In the combining mode, the flow from ports 2 and 4 will be combined into port 3. The division or combining will be maintained even if unequal loads are placed on ports 2 and 4.

The ST10-01 provides synchronizing flow in both combining and dividing modes at bottomed conditions in cylinder applications and at stalled conditions in motor applications. This feature is useful in hydraulic circuits that require cylinders to move at the same time. If one cylinder bottoms out first, the opposite cylinder is provided with a synchronizing flow to allow that cylinder to bottom before both cylinders start moving in the opposite direction.

Features

- All external surfaces zinc-plated
- Hardened parts to ensure minimal wear and extend service life
- One piece body maximizes reliability and minimizes the effects of eccentricity
- High accuracy operation
- Wide flow range down to 25% of nominal flow rating
- Low pressure drop
- Provides re-synchronizing flow after completion of the actuator cycle
- Industry common cavity

Specifications

Operating Pressure	5000 psi (350 bar)
Max. Input Flow	12 gpm (45 l/min)
Inlet Flow Options	2 gpm (7.6 l/min) 4 gpm (15.2 l/min) 6 gpm (22.8 l/min) 8 gpm (30.4 l/min) 10 gpm (37.8 l/min) 12 gpm (45.6 l/min)
Minimum Input Flow	Not less than 25% of Nominal Input flow
Fluid Operating Temp. Range	-4° to 248°F (-20° to +120°C) (Consult factory for usage at temp. outside range.)
Fluid Compatibility	Mineral-Based or Synthetics with lubricating properties
Viscosity	50 to 2000 SUS (7.4 to 420 cSt)
Filtration	21/19/16 or cleaner (per ISO 4406). Use with filter rated $\beta_{10} \geq 200$.
Installation	No orientation restrictions
Cavity	FC10-4 (see Line Bodies & Cavities section)
Cavity Tools	Rougher: 02580249 Finisher: 02582048
Cartridge Weight	0.27 lb (.122 kg)
Cartridge Material	Steel with hardened work surfaces. Zinc-plated exposed surfaces. Buna N or Viton® o-rings, and PTFE back-up rings.
Seal Kits	Buna-N P/N: 03051912 Viton® P/N: 03071275

Flow Division Accuracy

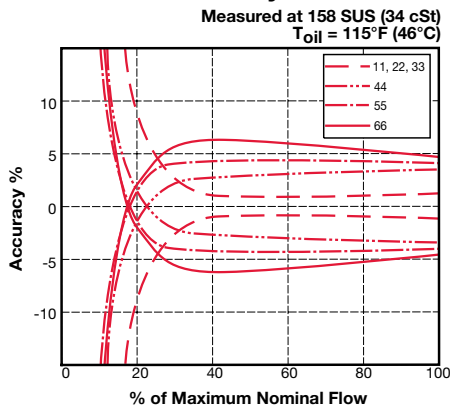

Dimensions

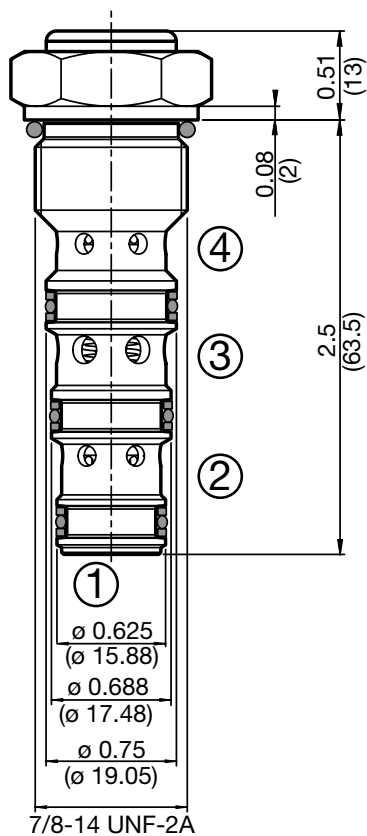
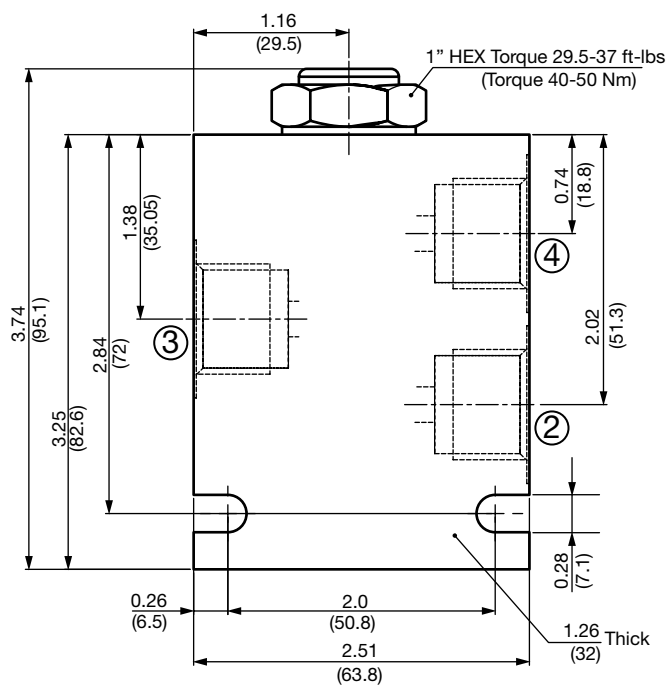

All measurements in inches (mm).
Subject to technical modifications

Model Code

ST10-01-C-N-22

Valve Model

Body & Ports

- C = No Line Body, cartridge only
- AS8 = SAE-8 ports, aluminum body
- SS8 = SAE-8 ports, steel body

Seals

- N = Buna-N
- V = Viton®

Flow Rate & Range

Code	Ratio Port 3 (%)	Ratio Port 4 (%)	Max. inlet flow gpm (l/min)	*Synchronization flow rate	
				Combining gpm (l/min) 2 - 4	Dividing gpm (l/min) 2 - 4
11	50	50	2 (7.6)	0.18 (0.7)	0.18 (0.7)
22	50	50	4 (15.2)	0.34 (1.3)	0.30 (1.1)
33	50	50	6 (22.8)	0.60 (2.3)	0.55 (2.1)
44	50	50	8 (30.4)	0.68 (2.6)	0.74 (2.8)
55	50	50	10 (37.8)	0.79 (3.0)	0.89 (3.4)
66	50	50	12 (45.6)	1.37 (5.2)	0.82 (3.1)

*at 100 bar (1450 psi)

Performance

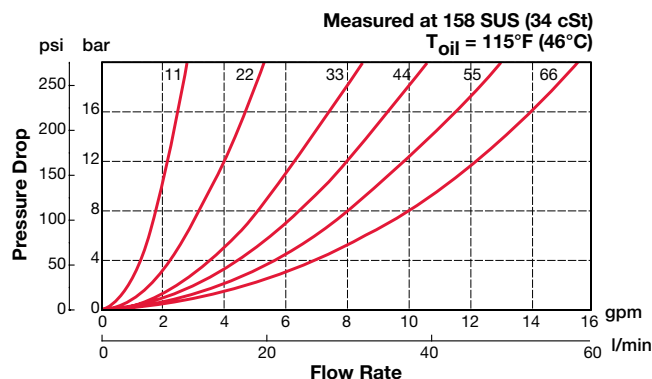

Standard Line Bodies*

Code	Part No	Material	Pressure Rating	Weight
FH1041-AS8**	02593311	Aluminum, anodized	3500 psi (245 bar)	0.34 lbs (0.15 kg)
FH1041-SS8**	02593312	Steel, Zinc plated	6000 psi (420 bar)	1.00 lbs (0.45 kg)

*Please refer to Line Bodies & Cavities section for details

**Standard line body (FH104) port 1 must be plugged when used with ST10.
Use SAE-8 plug, HYDAC part #02580005

FLOW CONTROL VALVES

ST16-01

Flow Divider/Combiner, Spool Type

Up to 40 gpm (150 l/min) • 5000 psi (350 bar)

Hydraulic Symbol

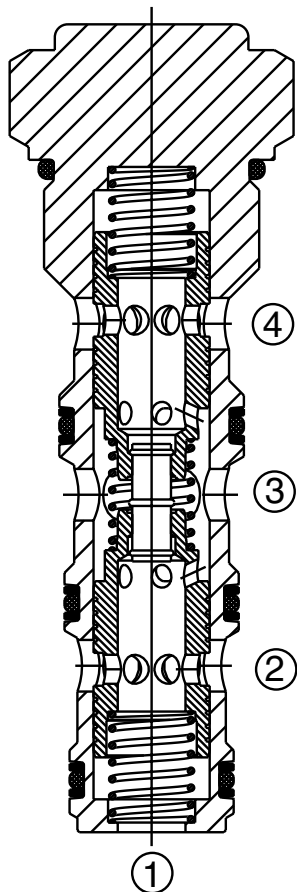
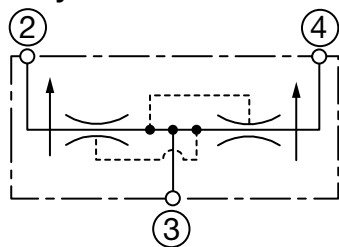

Description

A screw-in cartridge, spool type, pressure compensated flow divider/combiner.

Operation

In the dividing mode, ST16-01 divides the input flow on port 3 between ports 2 and 4, based on the specified ratio, regardless of the operating pressure. In the combining mode, the flow from ports 2 and 4 will be combined into port 3. The division or combining will be maintained even if unequal loads are placed on ports 2 and 4.

The ST16-01 provides synchronizing flow in both combining and dividing modes at bottomed conditions in cylinder applications and at stalled conditions in motor applications. This feature is useful in hydraulic circuits that require cylinders to move at the same time. If one cylinder bottoms out first, the opposite cylinder is provided with the synchronizing flow to allow that cylinder to bottom before both cylinders start moving in the opposite direction.

Features

- High accuracy operation
- Low pressure drop
- Wide flow range down to 25% of nominal flow rating
- Provides re-synchronizing flow after completion of the actuator cycle
- All external surfaces zinc-plated
- Hardened parts to ensure minimal wear and extend service life
- One-piece body maximizes reliability and minimizes the effect of eccentricity
- Industry common cavity

Specifications

Operating Pressure	5000 psi (350 bar)
Maximum Input Flow	40 gpm (150 l/min)
Inlet Flow Options	24 gpm (90 l/min) 30 gpm (115 l/min) 40 gpm (150 l/min)
Minimum Input Flow	Not less than 25% of Nominal Input flow
Fluid Operating Temp. Range	-4° to 248°F (-20° to +120°C) <i>(Consult factory for usage at temp. outside range.)</i>
Fluid Compatibility	Mineral-Based or Synthetics with lubricating properties
Viscosity	50 to 2000 SUS (7.4 to 420 cSt)
Filtration	21/19/16 or cleaner (per ISO 4406). Use with filter rated $\beta_{10} \geq 200$.
Installation	No orientation restrictions
Cavity	FC16-4 (see <i>Line Bodies & Cavities</i> section)
Cavity Tools	Rougher: 02580253 Finisher: 02580252
Cartridge Weight	1.02 lb (.465 kg)
Cartridge Material	Steel with hardened work surfaces. Zinc-plated exposed surfaces. Buna N or Viton® o-rings, and PTFE back-up rings.
Seal Kits	Buna-N FS164-N P/N: 03181644 Viton® FS164-V P/N: 03181675

Flow Division Accuracy

Measured at 158 SUS (34 cSt)
T_{oil} = 115°F (46°C)

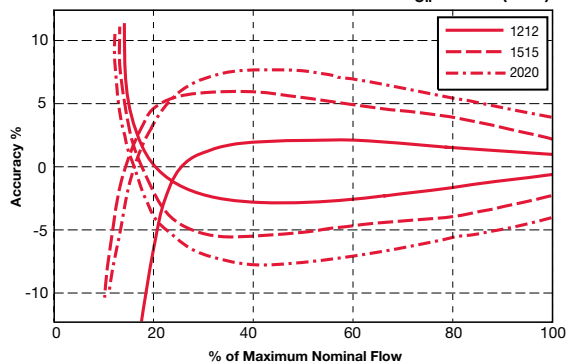

Dimensions

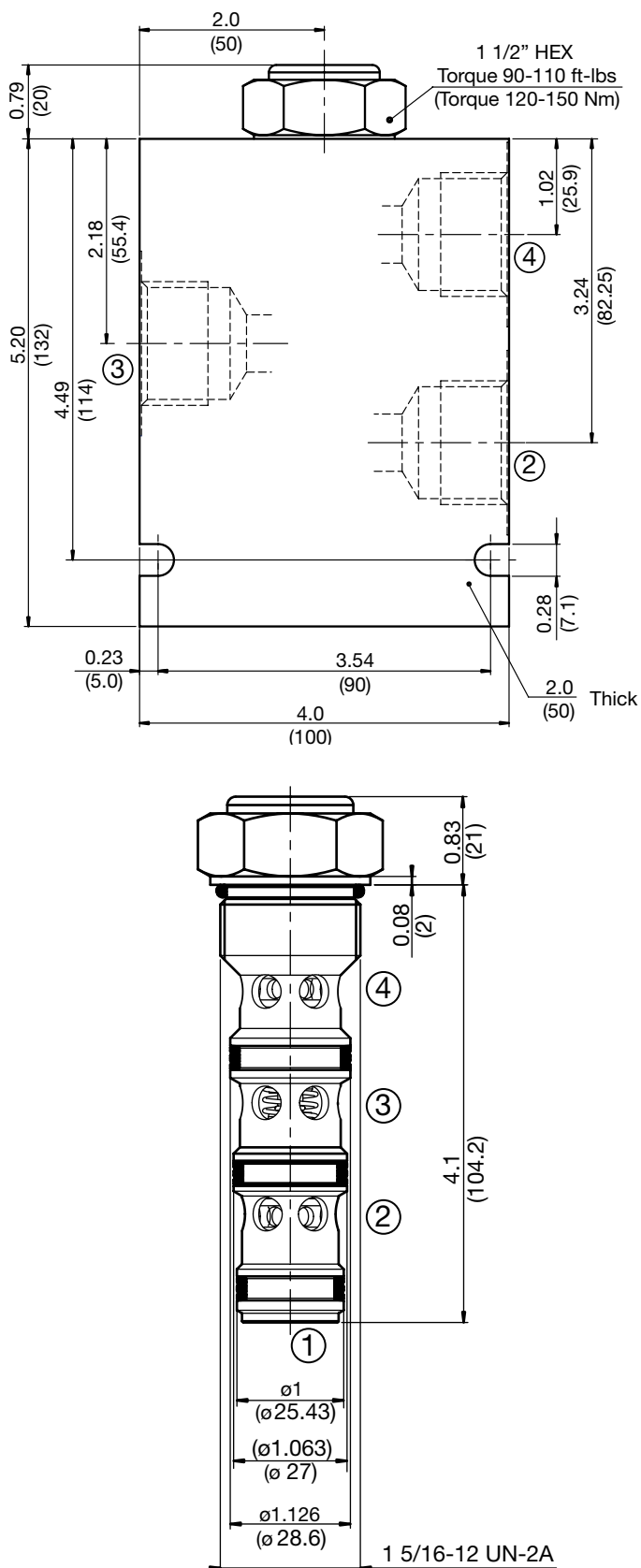

Model Code

ST16-01-C-N-2020

Valve Model

Body & Ports

- C = No Line Body, cartridge only
- AS16 = SAE-8 ports, aluminum body
- SS16 = SAE-8 ports, steel body

Seals

- N = Buna-N
- V = Viton®

Flow Rate & Range

Code	Ratio Port 3 (%)	Ratio Port 4 (%)	Max. inlet flow gpm (l/min)	*Synchronization flow rate gpm (l/min)
1212	50	50	24 (90)	1.8 (6.7)
1515	50	50	30 (115)	2.2 (8.3)
2020	50	50	40 (22.8)	2.6 (9.8)

*at 100 bar (1450 psi)

Performance

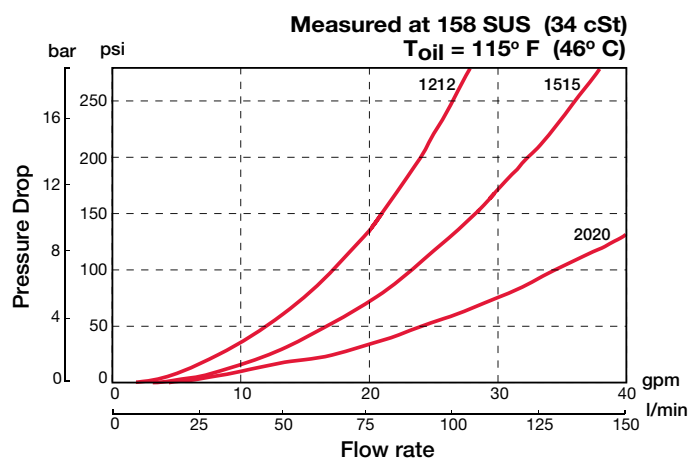

Standard Line Bodies*

Code	Part No	Material	Pressure Rating	Weight
FH1641-AS16**	02593313	Aluminum, anodized	3500 psi (245 bar)	3.00 lb (1.36 kg)
FH1641-SS16**	02593314	Steel, Zinc plated	6000 psi (420 bar)	8.8 lb (4.00 kg)

*Please refer to Line Bodies & Cavities section for details

**Standard line body (FH164) port 1 must be plugged when used with ST16. Use SAE-16 plug, HYDAC part #02581224.

All measurements in inches (mm).
Subject to technical modifications

FLOW CONTROL VALVES

Notes

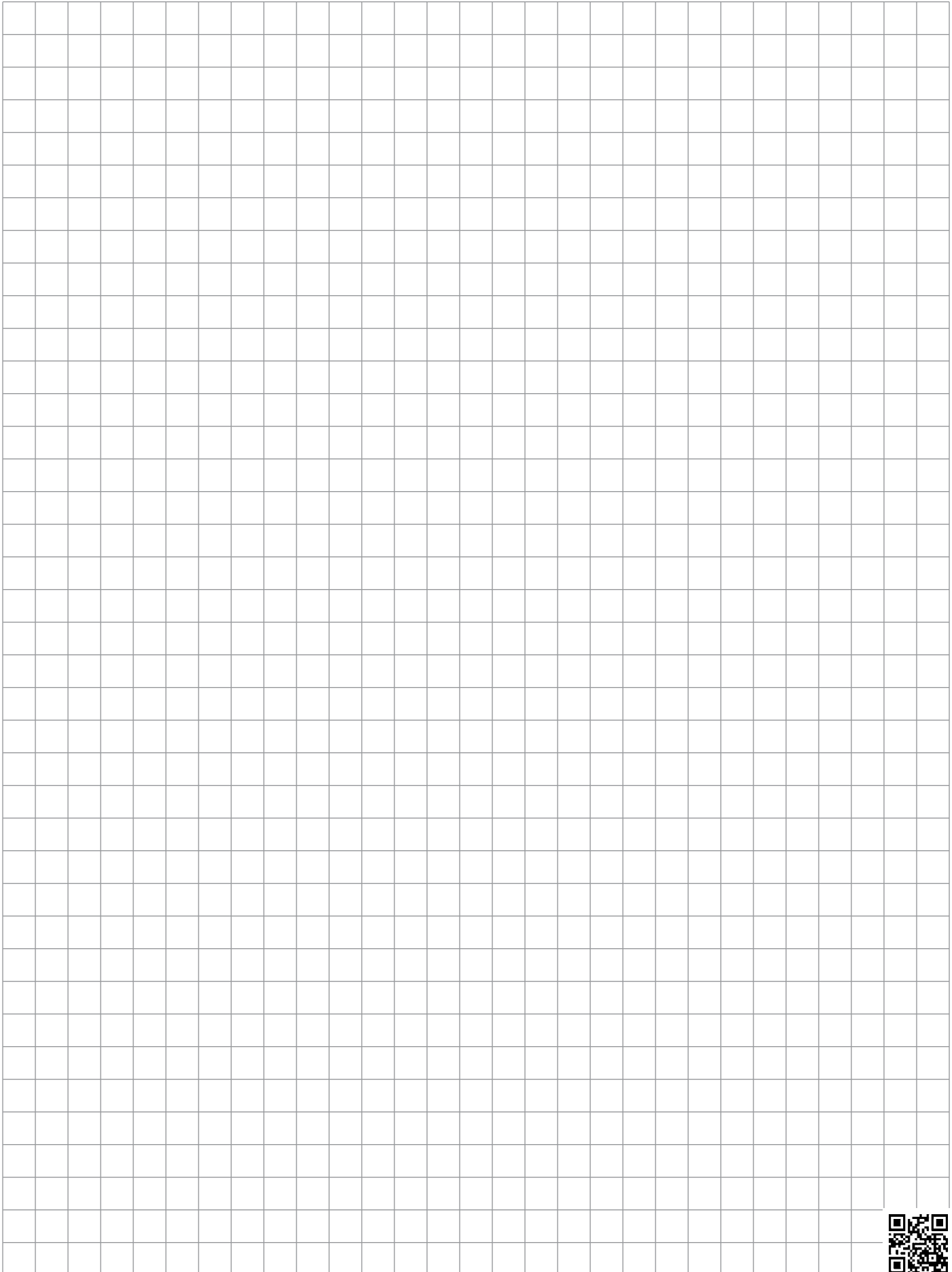
A large grid of graph paper for taking notes, consisting of 20 columns and 30 rows of small squares.



D1

Overview

The HYDAC range of direct and pilot operated check valves provide a broad selection of cartridge and inline products with operating pressure rating of up to 6000 psi (420 bar). All valves have a one piece body design and hardened balls or poppets. This provides an excellent product with reliable seating, 2 drops/minute maximum internal leakage, dirt-tolerance and long life.

Check Valves offer optional bias springs and flow capacity up to 44 gpm (165 l/min). Check valve cartridges fit into Industry standard cavities. A wide selection of cracking pressures are available from 5 to 70 psi (0.35 – 5 bar). Thus they could be used not only as a conventional check but also as a low pressure relief valves.

Pilot Operated Check Valves are available for flows up to 40 gpm (150 l/min) and pilot ratios 3:1 and 4:1. These valves positively lock a load from port 1 to port 2 until pilot pressure applied to port 3 is sufficient to unseat the valve. This flow path provides for higher flow rating in a given cavity, excellent stability and repeatability. They also fit into the same cavity as HYDAC counterbalance valves. These valves provide a low cost alternative to load control when the dynamics of neither overrunning loads nor load release speed are factors to be considered in the design of the hydraulic circuit. They are used for:

- Position load locking.
- As an alternative to counterbalance valves where neither the overrunning loads or release speed are factors in the application.

Single Pilot-to-Open Check Valves and **Dual Pilot-to Open Check Valves** are inline housed, pilot operated, hydraulic check valves for use as a blocking or load holding device for flow rates up to 20 gpm (80 l/min) and 6000 psi (420 bar). They feature:

- Hardened closing element in a check valve to ensure extended service life and 2 drops/min maximum internal leakage
- Multiple bias spring options for back pressure application flexibility
- Optional sealed pilot piston
- Check section serviceable as a cartridge
- All zinc-plated external cartridge surfaces
- Aluminum or steel inline housings

Counterbalance Valve RS08-01 is a compact cartridge design with operating pressure up to 5000 psi (350 bar) and flow rate up to 10 gpm (38 l/min). These valves are used for

- Precise control of overrunning loads
- Positive load holding in any position
- Protection from pump cavitation
- Thermal expansion relief protection
- Preventing actuators from running ahead of the pump supply

Counterbalance Valves have:

- A built in check valve feature allowing free flow in one direction
- A relief feature controlling flow in the other direction
- A pilot signal that overrides the relief setting providing the counterbalance function

CHECK & LOAD CONTROL VALVES

RP08A-01

Check Valve, Pilot-to-Open, Poppet Type

Up to 10 gpm (38 l/min) • 6000 psi (420 bar)

Hydraulic Symbol

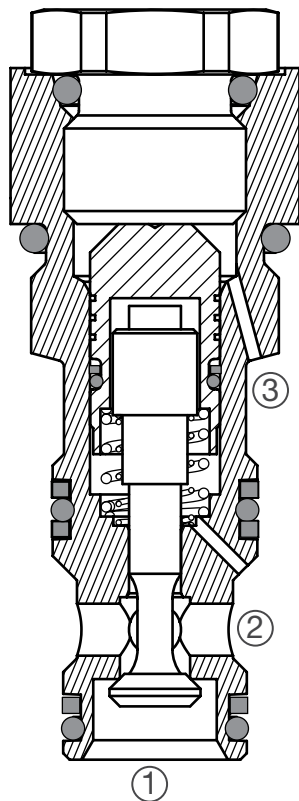
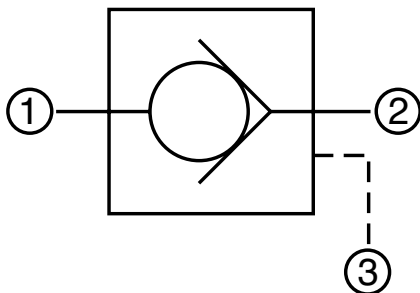

Description

A screw-in cartridge, poppet type pilot operated check valve for use as a blocking or load holding device.

Operation

The RP08A allows flow from port 2 to port 1, while normally blocking flow from port 1 to port 2. The valve remains closed by bias spring until sufficient pressure is applied at pilot port 3. The cartridge has 3:1 and 4:1 optional pilot ratios, meaning that at least one-third or one-fourth (respectively) of the load pressure held at port 1 is required at port 3 to open the valve. A sealed pilot piston option is available.

Features

- Hardened poppet to ensure extended service life and low leakage
- Additional reseating spring for fast and reliable closing
- Optional sealed pilot piston
- Higher flow rating and low pressure drop due to pilot port at 3.
- Same cavity as counterbalance valve RS08.
- All external surfaces zinc-plated or specifically treated
- Industry common cavity

Specifications

Operating Pressure	6000 psi (420 bar)
Nominal Flow	10 gpm (38 l/min)
Internal Leakage	2 drops/min. at 6000 psi (0.10 cc/min at 420 bar)
Pilot Ratio	3:1, 4:1
Standard Check Bias Spring	15 psi (1.0 bar)
Fluid Operating Temp. Range	-4° to 248°F (-20° to +120°C) (Consult factory for usage at temp. outside range.)
Fluid Compatibility	Mineral-based or synthetics with lubricating properties
Viscosity	50 to 2000 SUS (7.4 to 420 cSt)
Filtration	21/19/16 or cleaner (per ISO 4406). Use with filter rated $\beta_{10} \geq 200$.
Installation	No orientation restrictions
Cavity	FC08-3 (see <i>Line Bodies & Cavities</i> section)
Cavity Tools	Rougher: 02580086 Finisher: 02580087
Cartridge Weight	0.19 Lbs. (0.09 kg)
Cartridge Material	Steel with hardened work surfaces. Buna N or Viton® o-rings. PTFE back-up rings.
Seal Kits	Buna-N P/N: 03054795 Viton® P/N: 02591059

CHECK & LOAD CONTROL VALVES

Dimensions

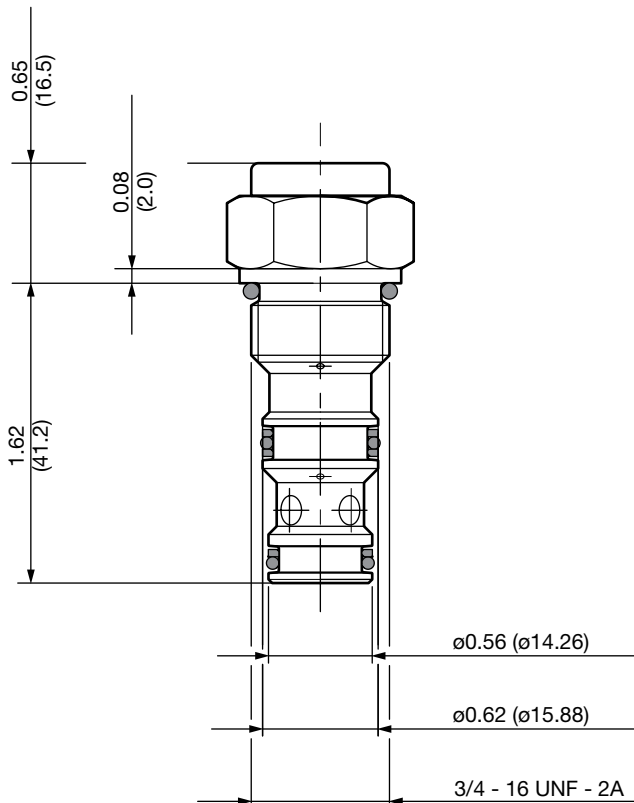
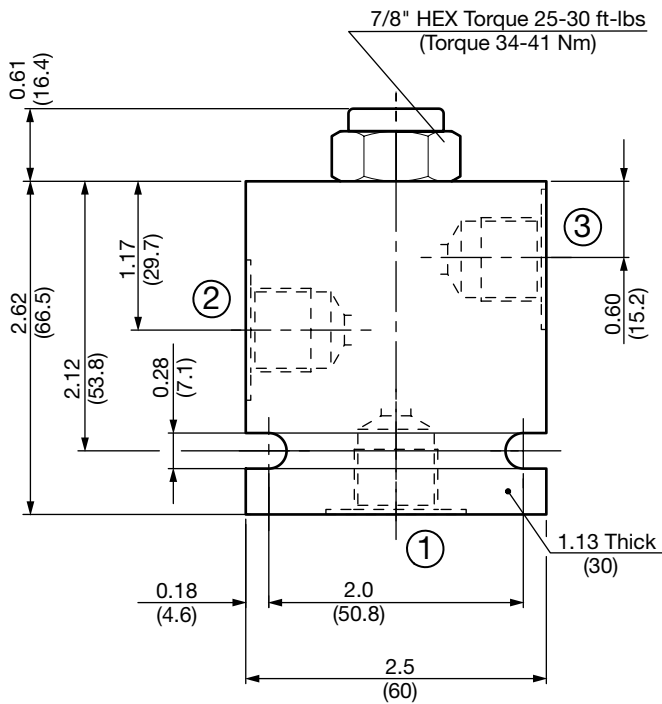

All measurements in inches (mm).
Subject to technical modifications

Model Code

RP08A-01-C-N-15-3

Valve Model

Body & Ports

- C = Cartridge only
- AS6 = SAE-6 Ports, aluminum Body
- SS6 = SAE-6 Ports, steel Body

Seals

- N = Buna-N
- NS = Buna-N with Sealed Piston
- V = Viton®
- VS = Viton® with Sealed Piston

Cracking Pressure

- 15 = 15 psi (1.00 bar)

Pilot Ratio

- 3 = 3:1
- 4 = 4:1

Performance

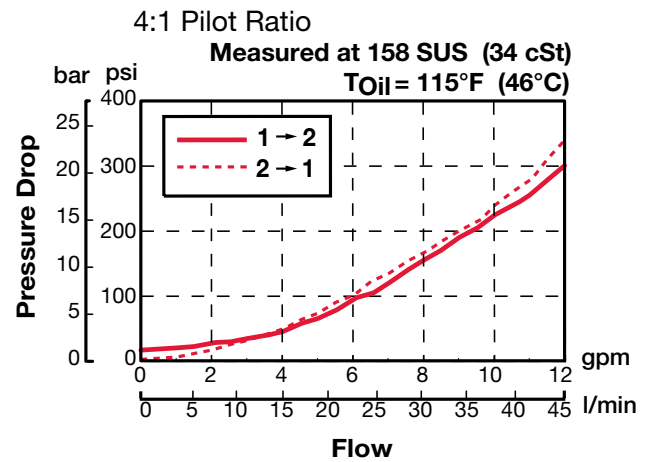
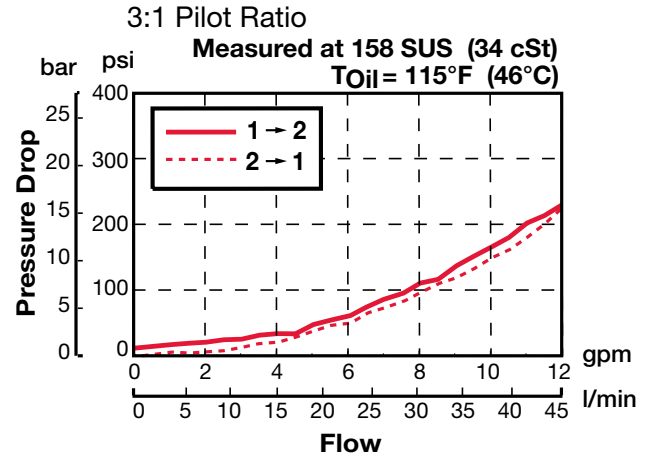

Standard Line Bodies*

Code	Part No	Material	Pressure Rating	Weight
FH083-AS6	03011424	Aluminum, anodized	3500 psi (245 bar)	0.58 lb (0.26 kg)
FH083-SS6	00560920	Steel, Zinc plated	6000 psi (420 bar)	1.70 lb (0.77 kg)

*Please refer to Line Bodies & Cavities section for details

CHECK & LOAD CONTROL VALVES

RP10A-01

Check Valve, Pilot-to-Open, Poppet Type

Up to 16 gpm (60 l/min) • 6000 psi (420 bar)

Hydraulic Symbol

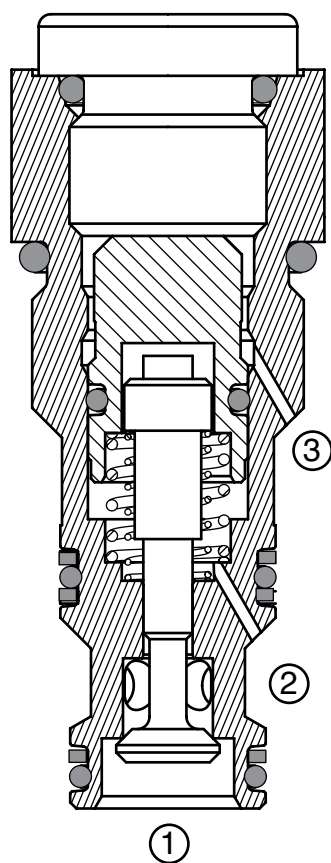
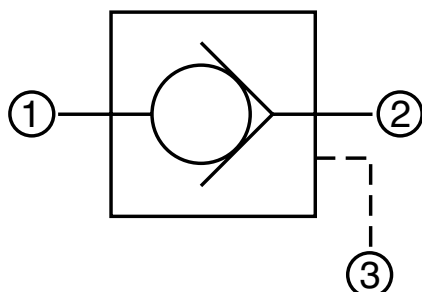

Description

A screw-in cartridge, poppet type pilot operated check valve for use as a blocking or load holding device.

Operation

The RP10A allows flow from port 2 to port 1, while normally blocking flow from port 1 to port 2. The valve remains closed by bias spring until sufficient pressure is applied at pilot port 3. The cartridge has 3:1 and 4:1 optional pilot ratios, meaning that at least one-third or one-fourth (respectively) of the load pressure held at port 1 is required at port 3 to open the valve. A sealed pilot piston option is available.

Features

- Hardened poppet to ensure extended service life and low leakage
- Additional reseating spring for fast and reliable closing
- Optional sealed pilot piston
- Higher flow rating and low pressure drop due to pilot port at 3.
- All external surfaces zinc-plated
- Industry common cavity

Specifications

Operating Pressure	6000 psi (420 bar)
Nominal Flow	16 gpm (60 l/min)
Internal Leakage	2 drops/min. at 6000 psi (0.10 cc/min at 420 bar)
Pilot Ratio	3:1, 4:1
Standard Check Bias Spring	15 psi (1.0 bar)
Fluid Operating Temp. Range	-4° to 248°F (-20° to +120°C) <i>(Consult factory for usage at temp. outside range.)</i>
Fluid Compatibility	Mineral-based or synthetics with lubricating properties
Viscosity	50 to 2000 SUS (7.4 to 420 cSt)
Filtration	21/19/16 or cleaner (per ISO 4406). Use with filter rated $\beta_{10} \geq 200$.
Installation	No orientation restrictions
Cavity	FC10-3 (see <i>Line Bodies & Cavities</i> section)
Cavity Tools	Rougher: 02580092 Finisher: 02580093
Cartridge Weight	0.31 Lbs. (0.14 kg)
Cartridge Material	Steel with hardened work surfaces. Zinc-plated exposed surfaces. Buna N or Viton® o-rings. PTFE back-up rings.
Seal Kits	Buna-N: FS103-N P/N: 03071274 Viton®: FS103-V P/N: 03049443

CHECK & LOAD CONTROL VALVES

Dimensions

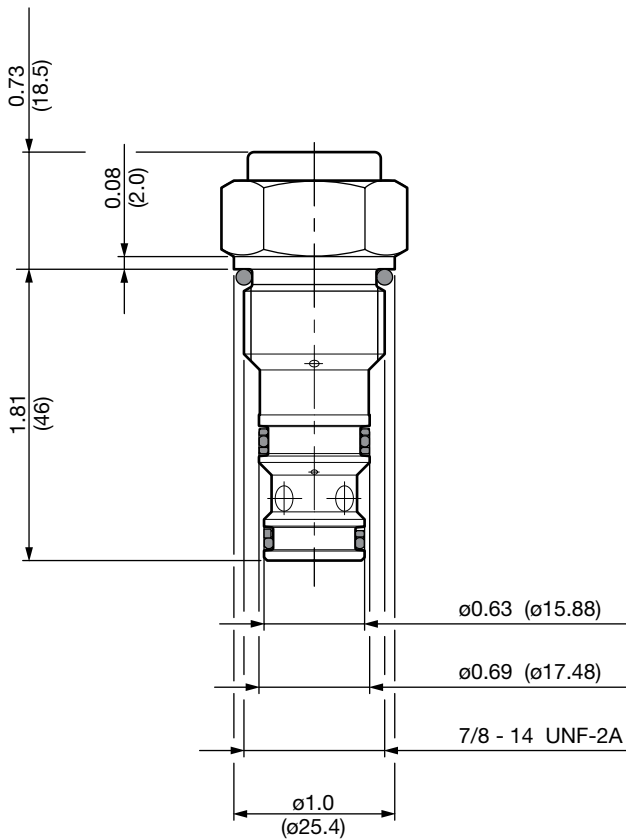
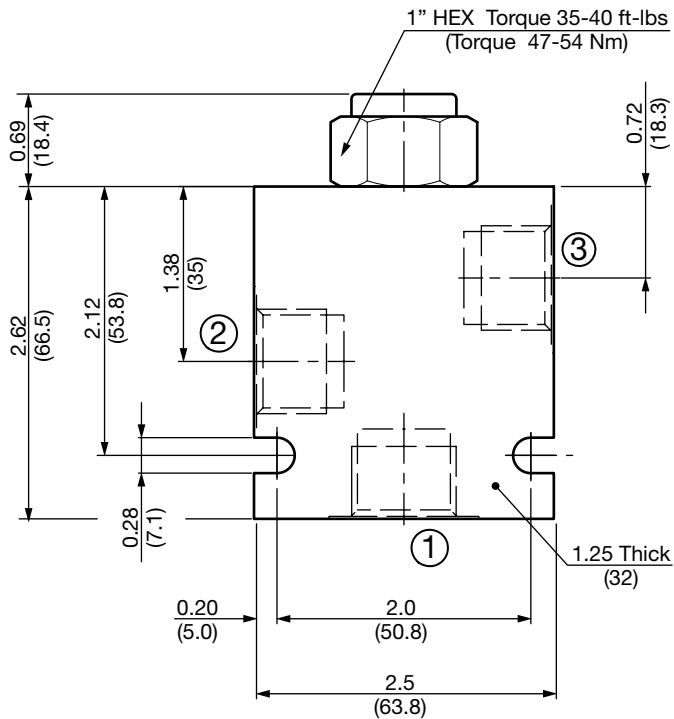

All measurements in inches (mm).
Subject to technical modifications

Model Code

RP10A-01-C-N-15-3

Valve Model	RP10A-01-C-N-15-3
Body & Ports	C = Cartridge only AS8 = SAE-8 Ports, aluminum Body SS8 = SAE-8 Ports, steel Body
Seals	N = Buna-N NS = Buna-N with Sealed Piston V = Viton® VS = Viton® with Sealed Piston
Cracking Pressure	15 = 15 psi (1.00 bar)
Pilot Ratio	3 = 3:1 4 = 4:1

Performance

3:1 Pilot Ratio

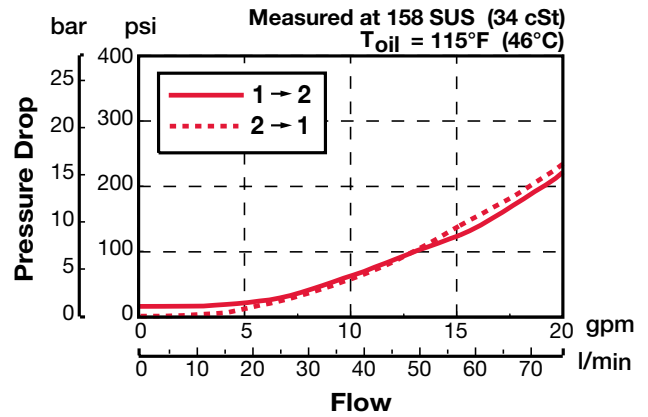

4:1 Pilot Ratio

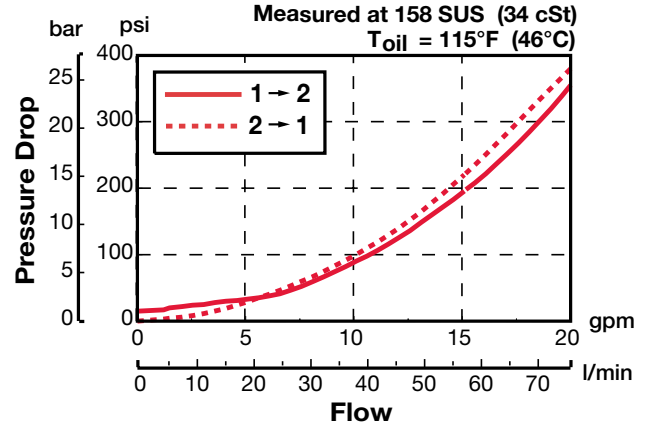

Standard Line Bodies*

Code	Part No	Material	Pressure Rating	Weight
FH103-AS8	03038095	Aluminum, anodized	3500 psi (245 bar)	0.60 lb (0.27 kg)
FH103-SS8	03037704	Steel, Zinc plated	6000 psi (420 bar)	1.74 lb (0.79 kg)

*Please refer to Line Bodies & Cavities section for details

CHECK & LOAD CONTROL VALVES

RP16A-01

Check Valve, Pilot-to-Open, Poppet Type

Up to 40 gpm (150 l/min) • 6000 psi (420 bar)

Hydraulic Symbol

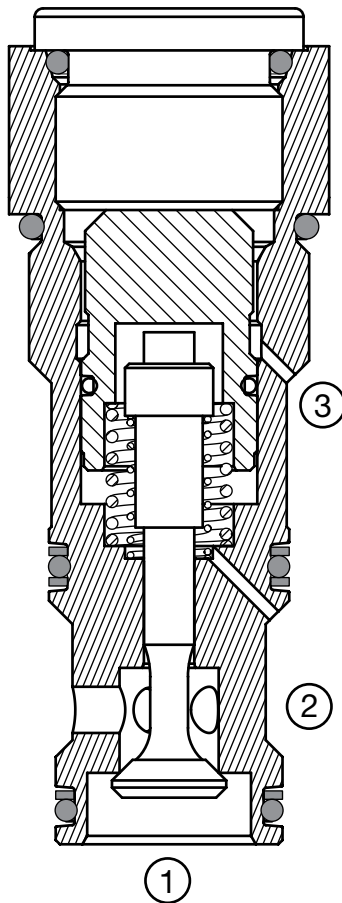
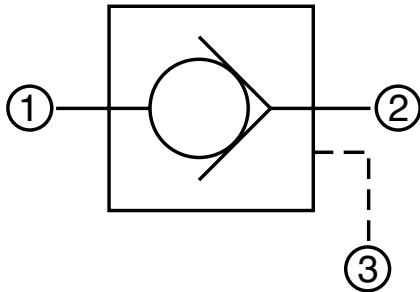

Description

A screw-in cartridge, poppet type pilot operated check valve for use as a blocking or load holding device.

Operation

The RP16A allows flow from port 2 to port 1, while normally blocking flow from port 1 to port 2. The valve remains closed by bias spring until sufficient pressure is applied at pilot port 3. The cartridge has 3:1 and 4:1 optional pilot ratios, meaning that at least one-third or one-fourth (respectively) of the load pressure held at port 1 is required at port 3 to open the valve.

A sealed pilot piston option is available.

Features

- Hardened poppet to ensure extended service life and low leakage
- Additional reseating spring for fast and reliable closing
- Optional sealed pilot piston
- Higher flow rating and low pressure drop due to pilot port at 3.
- All external surfaces zinc-plated
- Industry common cavity

Specifications

Operating Pressure	6000 psi (420 bar)
Nominal Flow	40 gpm (150 l/min)
Internal Leakage	2 drops/min. at 6000 psi (0.10 cc/min at 420 bar)
Pilot Ratio	3:1, 4:1
Standard Check Bias Spring	15 psi (1.0 bar)
Fluid Operating Temp. Range	-4° to 248°F (-20° to +120°C) <i>(Consult factory for usage at temp. outside range.)</i>
Fluid Compatibility	Mineral-based or synthetics with lubricating properties
Viscosity	50 to 2000 SUS (7.4 to 420 cSt)
Filtration	21/19/16 or cleaner (per ISO 4406). Use with filter rated $\beta_{10} \geq 200$.
Installation	No orientation restrictions
Cavity	FC16-3 (see <i>Line Bodies & Cavities</i> section)
Cavity Tools	Rougher: 02580094 Finisher: 02580095
Cartridge Weight	1.13 Lbs. (0.51 kg)
Cartridge Material	Steel with hardened work surfaces. Zinc-plated exposed surfaces. Buna N or Viton® o-rings. PTFE back-up rings.
Seal Kits	Buna-N FS163-N P/N: 03071303 Viton® FS082-V P/N: 03071304

CHECK & LOAD CONTROL VALVES

Dimensions

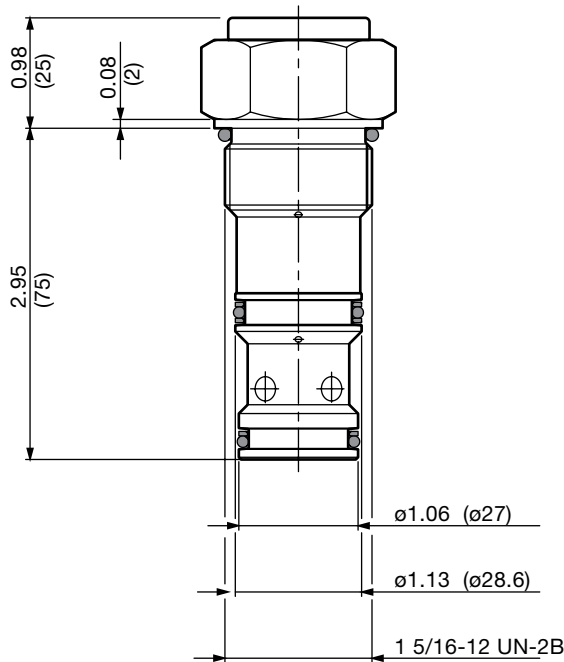
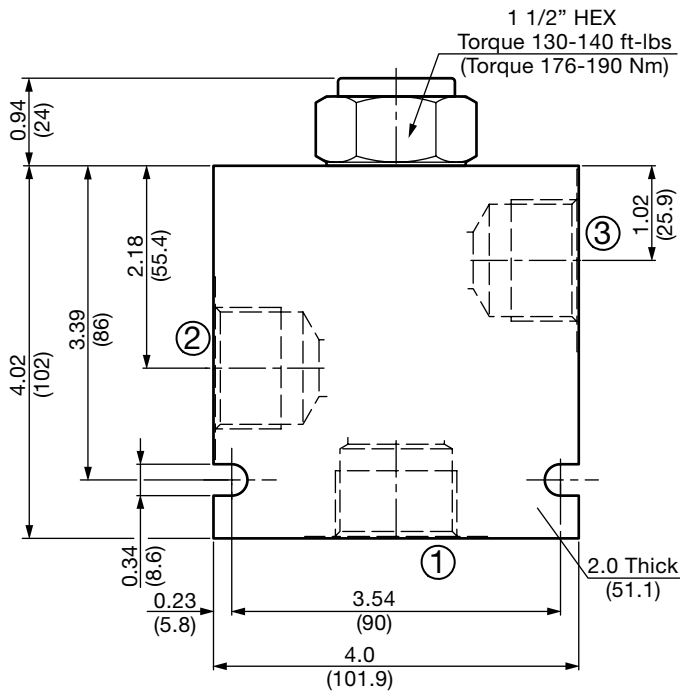

All measurements in inches (mm).
Subject to technical modifications

Model Code

RP16A-01-C-N-15-3

Valve Model

Body & Ports

- C = Cartridge only
- AS16 = SAE-16 Ports, aluminum Body
- SS16 = SAE-16 Ports, steel Body

Seals

- N = Buna-N
- NS = Buna-N with Sealed Piston
- V = Viton®
- VS = Viton® with Sealed Piston

Cracking Pressure

- 15 = 15 psi (1.00 bar)

Pilot Ratio

- 3 = 3:1
- 4 = 4:1

Performance

3:1 Pilot Ratio

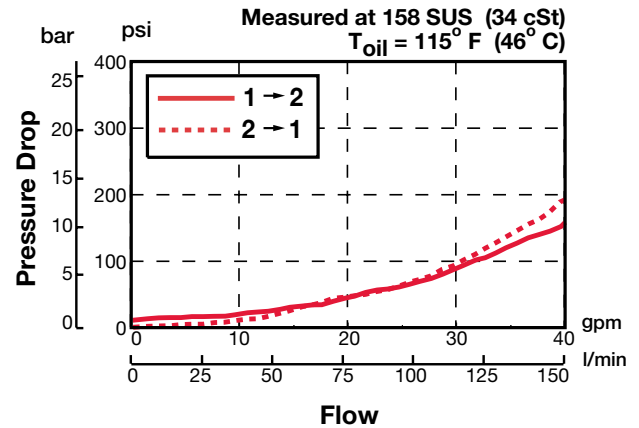

4:1 Pilot Ratio

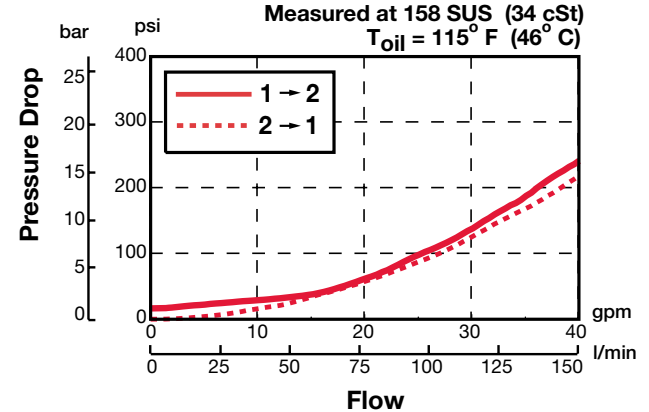

Standard Line Bodies*

Code	Part No	Material	Pressure Rating	Weight
FH163-AS16	03037210	Aluminum, anodized	3500 psi (245 bar)	2.34 lb (1.06 kg)
FH163-SS16	03036285	Steel, Zinc plated	6000 psi (420 bar)	6.80 lb (3.09 kg)

*Please refer to Line Bodies & Cavities section for details

CHECK & LOAD CONTROL VALVES

RV06A-01

Check Valve, Ball Type

Up to 5 gpm (19 l/min) • 5000 psi (350 bar)

Hydraulic Symbol

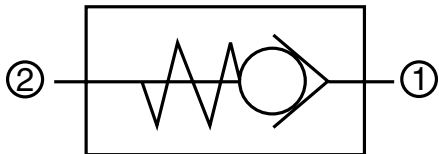

Description

A screw-in cartridge, ball type check valve for use as a blocking or load holding device.

Operation

The RV06A allows flow from port 1 to port 2, while normally blocking flow in the opposite direction.

The valve remains closed by bias spring until sufficient pressure is applied at port 1 at which time the ball lifts off the seat and allows flow from port 1 to port 2.

Features

- Hardened closing element to ensure extended service life and low leakage
- Multiple bias spring options for back pressure application flexibility
- Fast closing and seating
- All external surfaces zinc-plated

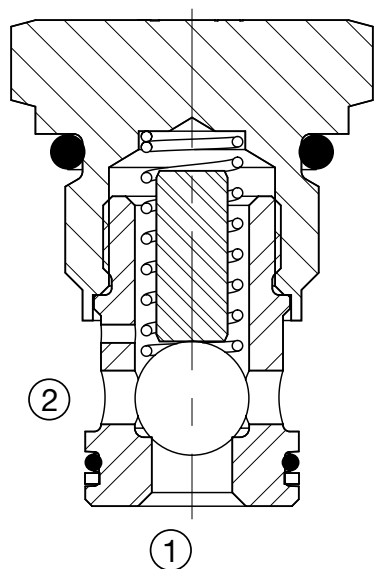

Specifications

Operating Pressure	5000 psi (350 bar)
Maximum Flow Rate	5 gpm (19 l/min)
Internal Leakage	5 drops/min at 5000 psi (350 bar)
Standard Cracking Pressures	5 psi (0.35 bar) 30 psi (2.1 bar)
Fluid Operating Temp. Range	-20° to 248°F (-29° to 120°C)
Fluid Compatibility	Mineral-Based or Synthetics with lubricating properties
Viscosity	50 to 2000 SUS (7.4 to 420 cSt)
Filtration	21/19/16 or cleaner per (ISO 4406)
Installation	No orientation restrictions
Cavity	FC06-2 (see <i>Line Bodies & Cavities</i> section)
Cavity Tools	Rougher: 02582046 Finisher: 02582047
Cartridge Weight	0.1 lb (45 g)
Cartridge Material	Steel with hardened work surfaces. Zinc plated exposed surfaces. Buna N or Viton® o-rings. Solid thermoplastic polyester back-up rings.
Seal Kits	Buna-N FS062-N P/N: 02610184 Viton® FS062-V P/N: 02610185

Performance

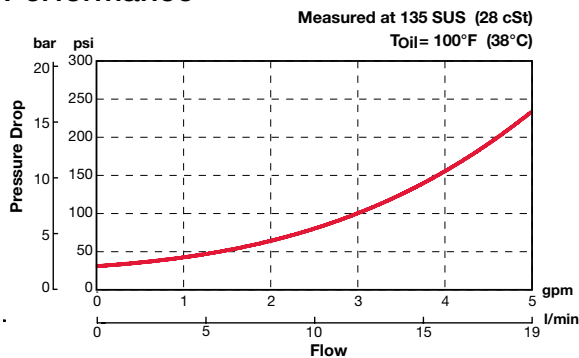

CHECK & LOAD CONTROL VALVES

Dimensions

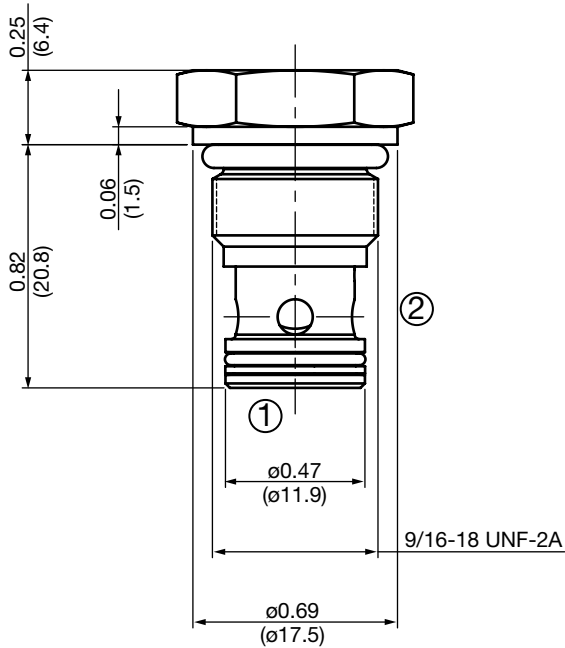
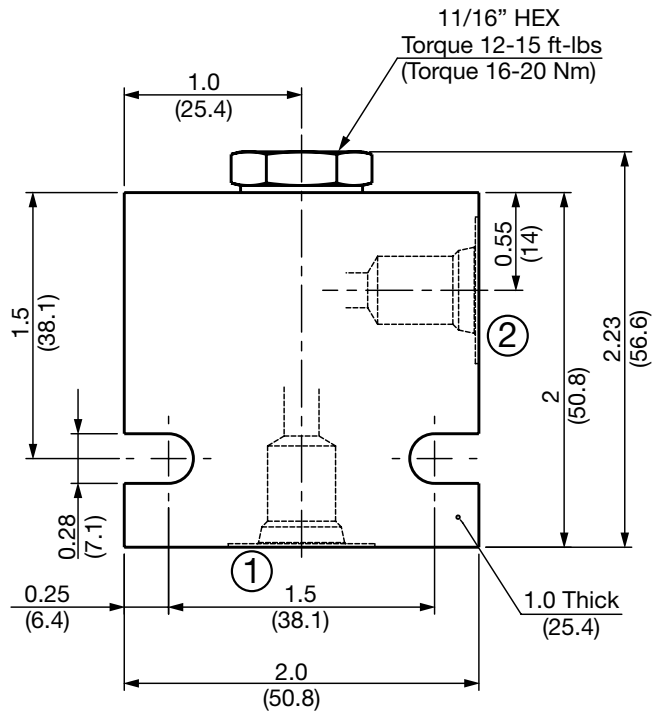

Model Code

RV06A-01-AS4-N-30

Valve Model

Body & Ports

- C = Cartridge only
- AS4 = SAE-4 Ports, aluminum Body
- SS4 = SAE-4 Ports, steel Body

Seals

- N = Buna-N
- V = Viton®

Cracking Pressure

- 5 = 5 psi (0.35 bar)
- 30 = 30 psi (2.1 bar)

All measurements in inches (mm).
Subject to technical modifications

Standard Line Bodies*

Code	Part No	Material	Pressure Rating	Weight
FH062-AS4	02600491	Aluminum, anodized	3500 psi (245 bar)	0.34 lbs (0.15 kg)
FH062-SS4	02600490	Steel, Zinc plated	6000 psi (420 bar)	1.0 lbs (0.45 kg)

*Please refer to Line Bodies & Cavities section for details

CHECK & LOAD CONTROL VALVES

RV08A-01

Check Valve, Ball Type

Up to 10 gpm (38 l/min) • 6000 psi (420 bar)

Hydraulic Symbol

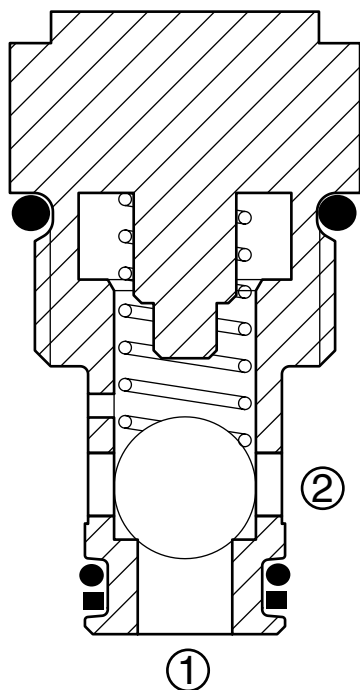
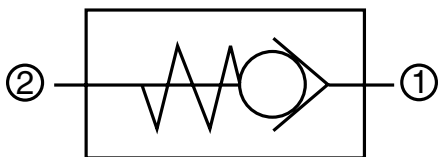

Description

A screw-in cartridge, ball type check valve for use as a blocking or load holding device.

Operation

The RV08A allows flow from port 1 to port 2, while normally blocking flow in the opposite direction. The valve remains closed by bias spring until sufficient pressure is applied at port 1 at which time the ball lifts off the seat and allows flow from port 1 to port 2.

Features

- Hardened closing element to ensure extended service life and low leakage
- Multiple bias spring options for back pressure application flexibility
- Fast closing and seating
- Low pressure drop
- All external surfaces zinc-plated
- Industry common cavity

Specifications

Operating Pressure	6000 psi (420 bar)
Nominal Flow	10 gpm (38 l/min)
Internal Leakage	>2 drops/min. at 6000 psi (0.10 cc/min at 420 bar)
Standard Cracking Pressures	5 psi (0.35 bar) 15 psi (1.00 bar) 30 psi (2.00 bar) 70 psi (5.00 bar)
Fluid Operating Temp. Range	-4° to 248°F (-20° to +120°C) <i>(Consult factory for usage at temp. outside range.)</i>
Fluid Compatibility	Mineral-based or synthetics with lubricating properties
Viscosity	50 to 2000 SUS (7.4 to 420 cSt)
Filtration	21/19/16 or cleaner (per ISO 4406). Use with filter rated $\beta_{10} \geq 200$.
Installation	No orientation restrictions
Cavity	FC08-2 (see <i>Line Bodies & Cavities</i> section)
Cavity Tools	Rougher: 02580090 Finisher 02580091
Cartridge Weight	0.13 Lbs. (0.06 kg)
Cartridge Material	Steel with hardened work surfaces. Zinc-plated exposed surfaces. Buna N or Viton® o-rings. PTFE back-up rings.
Seal Kits	Buna-N P/N: 03033920 Viton® P/N: 03051756

Performance

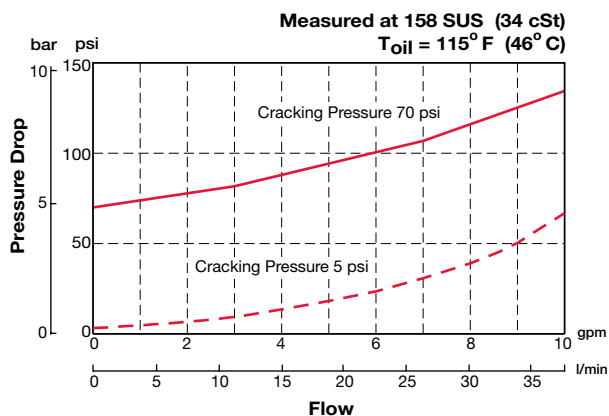

CHECK & LOAD CONTROL VALVES

Dimensions

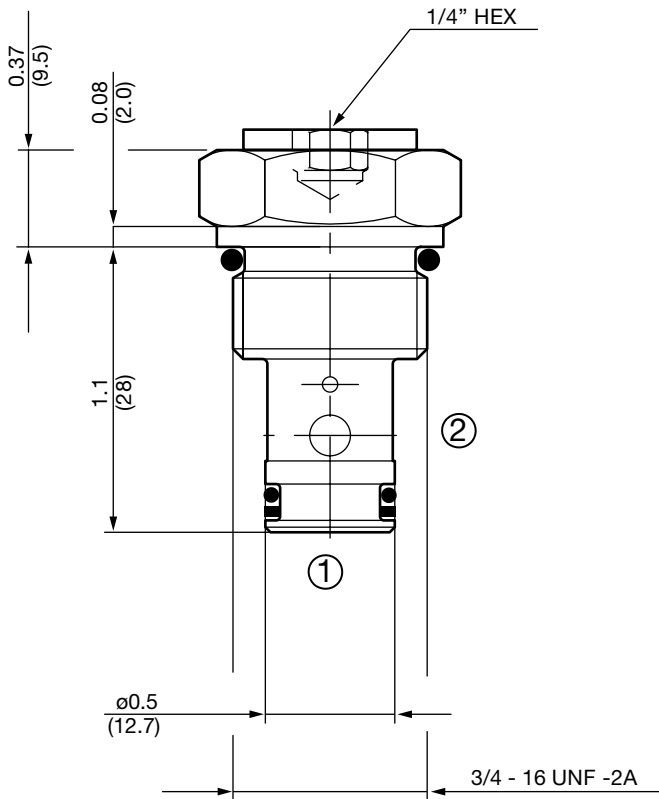
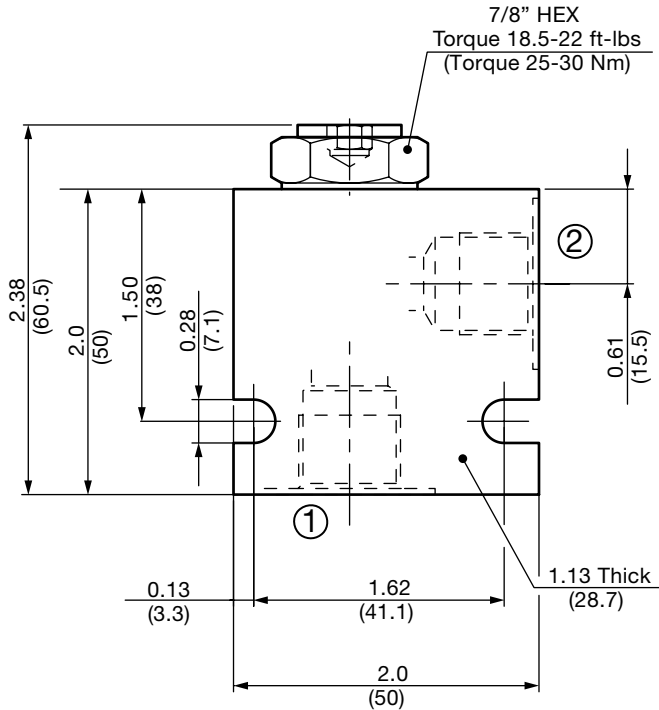

Model Code

RV08A-01-C-N-05

- Valve Model** _____
- Body & Ports** _____
- C = Cartridge only
 - AS6 = SAE-6 Ports, aluminum Body
 - SS6 = SAE-6 Ports, steel Body
- Seals** _____
- N = Buna-N
 - V = Viton®
- Cracking Pressure** _____
- 05 = 5 psi (0.35 bar)
 - 15 = 15 psi (1.00 bar)
 - 30 = 30 psi (2.00 bar)
 - 70 = 70 psi (5.00 bar)

All measurements in inches (mm).
Subject to technical modifications

Standard Line Bodies*

Code	Part No	Material	Pressure Rating	Weight
FH082-AS6	03011409	Aluminum, anodized	3500 psi (245 bar)	0.34 lb (0.15 kg)
FH082-SS6	00560917	Steel, Zinc plated	6000 psi (420 bar)	1.0 lb (0.45 kg)

*Please refer to Line Bodies & Cavities section for details

CHECK & LOAD CONTROL VALVES

RV10A-01

Check Valve, Ball Type

Up to 21 gpm (80 l/min) • 5000 psi (350 bar)

Hydraulic Symbol

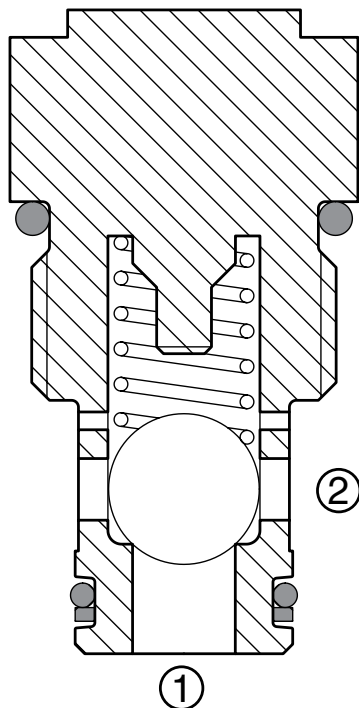
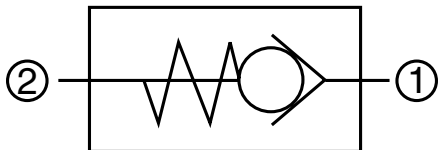

Description

A screw-in cartridge, ball type check valve for use as a blocking or load holding device.

Operation

The RV10A allows flow from port 1 to port 2, while normally blocking flow in the opposite direction. The valve remains closed by bias spring until sufficient pressure is applied at port 1 at which time the ball lifts off the seat and allows flow from port 1 to port 2.

Features

- Hardened closing element to ensure extended service life and low leakage
- Multiple bias spring options for back pressure application flexibility
- Fast closing and seating
- Low pressure drop
- All external surfaces zinc-plated
- Industry common cavity

Specifications

Operating Pressure	5000 psi (350 bar)
Nominal Flow	21 gpm (80 l/min)
Internal Leakage	<2 drops/min. at 6000 psi (0.10 cc/min at 420 bar)
Standard Cracking Pressures	5 psi (0.35 bar) 15 psi (1.00 bar) 30 psi (2.00 bar) 70 psi (5.00 bar)
Fluid Operating Temp. Range	-4° to 248°F (-20° to +120°C) (Consult factory for usage at temp. outside range.)
Fluid Compatibility	Mineral-based or synthetics with lubricating properties
Viscosity	50 to 2000 SUS (7.4 to 420 cSt)
Filtration	21/19/16 or cleaner (per ISO 4406). Use with filter rated $\beta_{10} \geq 200$.
Installation	No orientation restrictions
Cavity	FC10-2 (see Line Bodies & Cavities section)
Cavity Tools	Rougher: 02580274 Finisher: 02580247
Cartridge Weight	0.22 Lbs. (0.10 kg)
Cartridge Material	Steel with hardened work surfaces. Zinc-plated exposed surfaces. Anodized aluminum knobs. (option H) Buna N or Viton® o-rings. PTFE back-up rings.
Seal Kits	Buna-N P/N: 03033872 Viton® P/N: 03051757

Performance

Measured at 158 SUS (34 cSt)
T_{Oil} = 115° F (46° C)

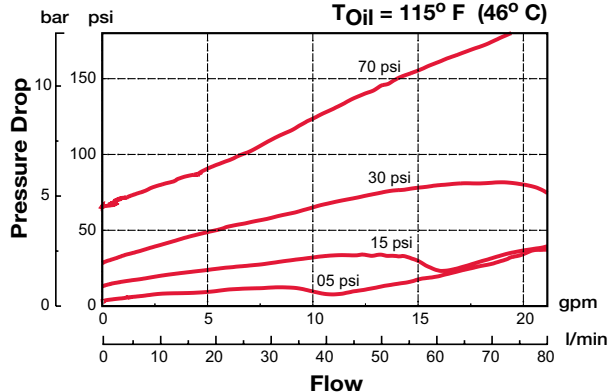

CHECK & LOAD CONTROL VALVES

Dimensions

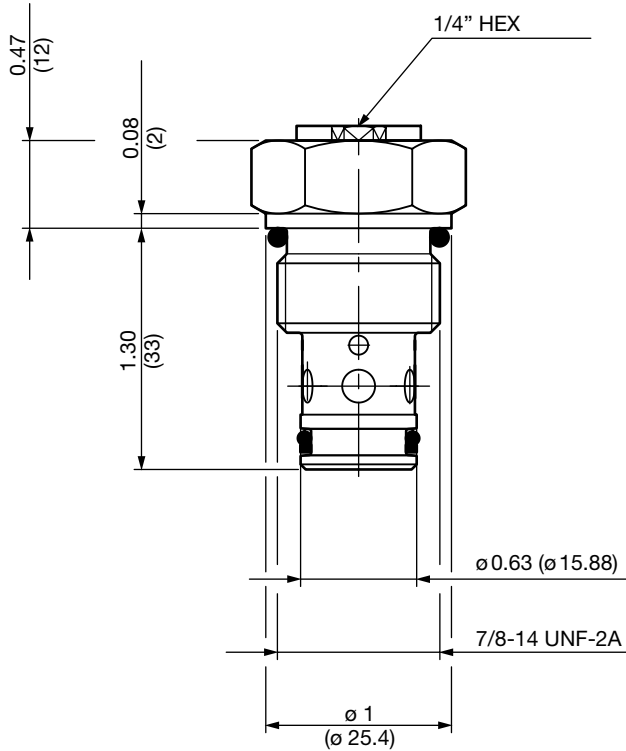
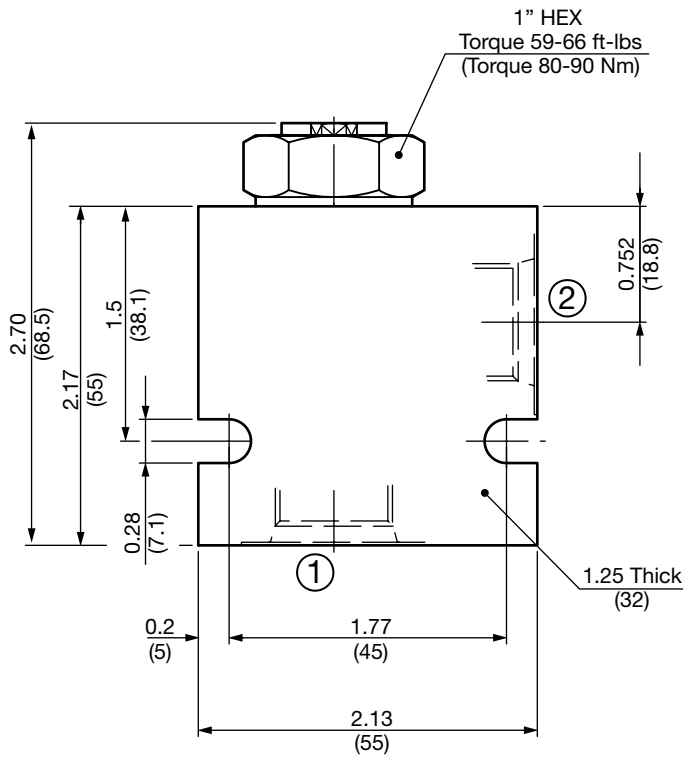

All measurements in inches (mm).
Subject to technical modifications

Model Code

RV10A-01-C-N-05

- Valve Model** _____
- Body & Ports** _____
- C = Cartridge only
 - AS8 = SAE-8 Ports, aluminum Body
 - SS8 = SAE-8 Ports, steel Body
- Seals** _____
- N = Buna-N
 - V = Viton®
- Cracking Pressure** _____
- 05 = 5 psi (0.35 bar)
 - 15 = 15 psi (1.00 bar)
 - 30 = 30 psi (2.00 bar)
 - 70 = 70 psi (5.00 bar)

Standard Line Bodies*

Code	Part No	Material	Pressure Rating	Weight
FH102-AS8	03037778	Aluminum, anodized	3500 psi (245 bar)	0.40 lb (0.18 kg)
FH102-SS8	03037612	Steel, Zinc plated	6000 psi (420 bar)	1.16 lb (0.53 kg)

*Please refer to Line Bodies & Cavities section for details

CHECK & LOAD CONTROL VALVES

RV12A-01

Check Valve, Poppet Type

Up to 31 gpm (120 l/min) • 6000 psi (420 bar)

Hydraulic Symbol

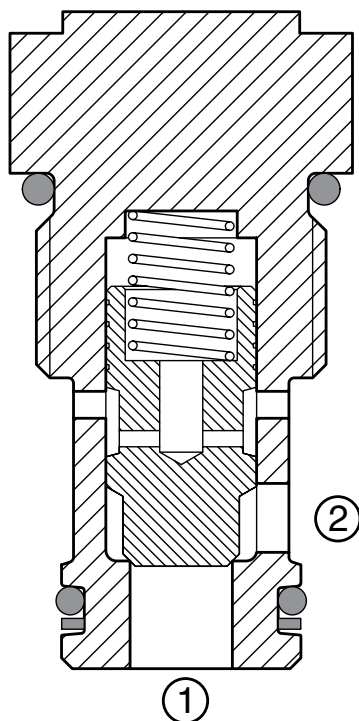
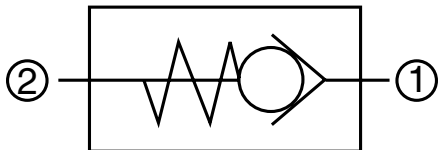

Description

A screw-in cartridge, poppet type check valve for use as a blocking or load holding device.

Operation

The RV12A allows flow from port 1 to port 2, while normally blocking flow in the opposite direction. The valve remains closed by bias spring until sufficient pressure is applied at port 1 at which time the poppet lifts off the seat and allows flow from port 1 to port 2.

Features

- Hardened closing element to ensure extended service life and low leakage
- Multiple bias spring options for back pressure application flexibility
- Fast closing and seating
- Low pressure drop
- Fully guided check
- All external surfaces zinc-plated
- Industry common cavity

Specifications

Operating Pressure	6000 psi (420 bar)
Nominal Flow	31 gpm (120 l/min)
Internal Leakage	<2 drops/min. at 6000 psi (0.10 cc/min at 420 bar)
Standard Cracking Pressures	5 psi (0.35 bar) 12 psi (0.80 bar) 25 psi (1.70 bar) 50 psi (3.40 bar)
Fluid Operating Temp. Range	-4° to 248°F (-20° to +120°C) (Consult factory for usage at temp. outside range.)
Fluid Compatibility	Mineral-based or synthetics with lubricating properties
Viscosity	50 to 2000 SUS (7.4 to 420 cSt)
Filtration	21/19/16 or cleaner (per ISO 4406). Use with filter rated $\beta_{10} \geq 200$.
Installation	No orientation restrictions
Cavity	FC12-2 (see Line Bodies & Cavities section)
Cavity Tools	Rougher: 02580667 Finisher: 02580668
Cartridge Weight	0.44 Lbs. (0.20 kg)
Cartridge Material	Steel with hardened work surfaces. Zinc-plated exposed surfaces. Buna N or Viton® o-rings. PTFE back-up rings.
Seal Kits	Buna-N P/N: 03071298 Viton® P/N: 03071299

Performance

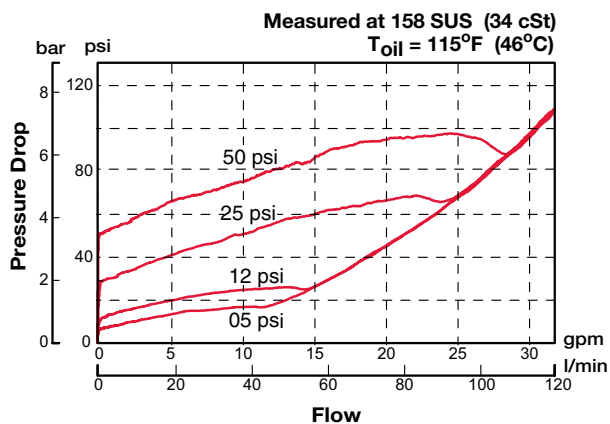

CHECK & LOAD CONTROL VALVES

Dimensions

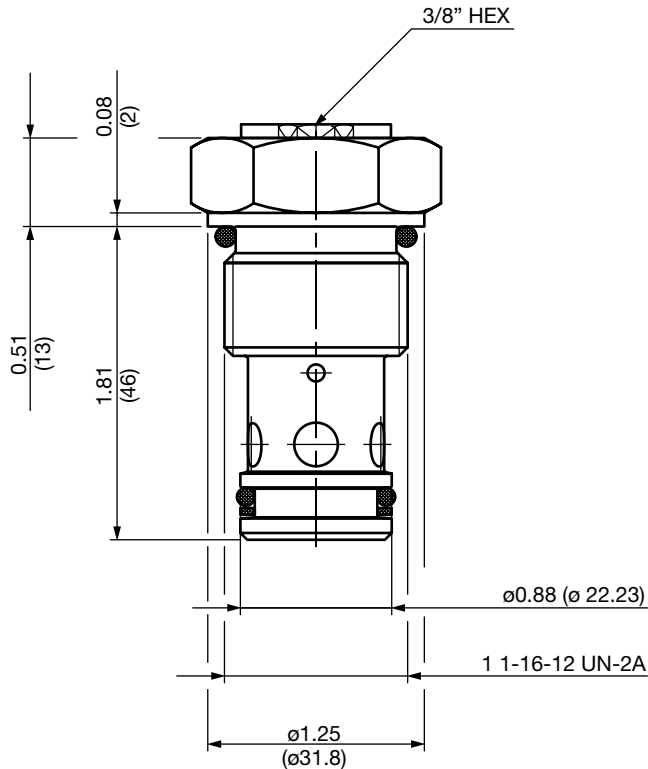
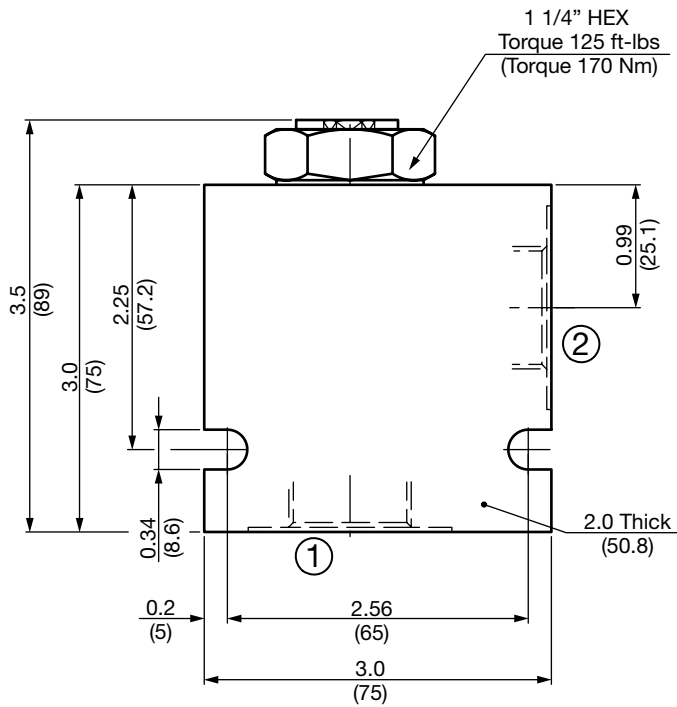

All measurements in inches (mm).
Subject to technical modifications

Model Code

RV12A-01-C-N-05

Valve Model

Body & Ports

- C = Cartridge only
- AS12 = SAE-12 Ports, aluminum Body
- SS12 = SAE-12 Ports, steel Body

Seals

- N = Buna-N
- V = Viton®

Cracking Pressure

- 05 = 5 psi (0.35 bar)
- 12 = 12 psi (0.80 bar)
- 25 = 25 psi (1.70 bar)
- 50 = 50 psi (3.40 bar)

Standard Line Bodies*

Code	Part No	Material	Pressure Rating	Weight
FH122-AS12	03053845	Aluminum, anodized	3500 psi (245 bar)	1.20 lb (0.55 kg)
FH122-SS12	03053772	Steel, Zinc plated	6000 psi (420 bar)	3.56 lb (1.62 kg)

*Please refer to Line Bodies & Cavities section for details

CHECK & LOAD CONTROL VALVES

RV16A-01

Check Valve, Poppet Type

Up to 44 gpm (165 l/min) • 6000 psi (420 bar)

Hydraulic Symbol

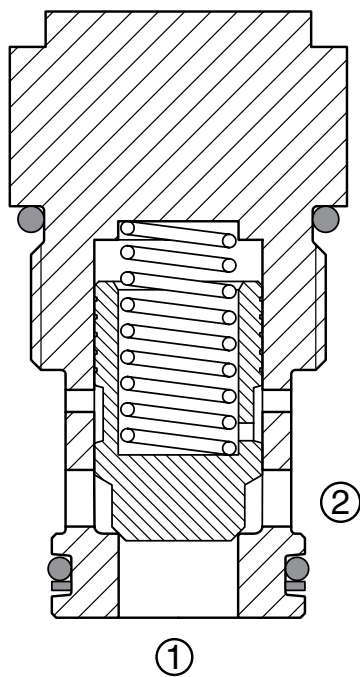
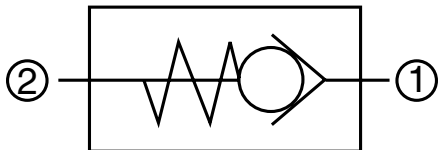

Description

A screw-in cartridge, poppet type check valve for use as a blocking or load holding device.

Operation

The RV16A allows flow from port 1 to port 2, while normally blocking flow in the opposite direction. The valve remains closed by bias spring until sufficient pressure is applied at port 1 at which time the poppet lifts off the seat and allows flow from port 1 to port 2.

Features

- Hardened poppet to ensure extended service life and low leakage
- Multiple bias spring options for back pressure application flexibility
- Fast closing and seating
- Low pressure drop
- Fully guided check
- All external surfaces zinc-plated
- Industry common cavity

Specifications

Operating Pressure	6000 psi (420 bar)
Nominal Flow	44 gpm (165 l/min)
Internal Leakage	<2 drops/min. at 6000 psi (0.10 cc/min at 420 bar)
Standard Cracking Pressures	5 psi (0.35 bar) 15 psi (1.00 bar) 30 psi (2.00 bar) 70 psi (5.00 bar)
Fluid Operating Temp. Range	-4° to 248°F (-20° to +120°C) (Consult factory for usage at temp. outside range.)
Fluid Compatibility	Mineral-based or synthetics with lubricating properties
Viscosity	50 to 2000 SUS (7.4 to 420 cSt)
Filtration	21/19/16 or cleaner (per ISO 4406). Use with filter rated $\beta_{10} \geq 200$.
Installation	No orientation restrictions
Cavity	FC16-2 (see Line Bodies & Cavities section)
Cavity Tools	Rougher: 02580250 Finisher: 02580251
Cartridge Weight	0.76 Lbs. (0.35 kg)
Cartridge Material	Steel with hardened work surfaces. Zinc-plated exposed surfaces. Buna N or Viton® o-rings. PTFE back-up rings.
Seal Kits	Buna-N P/N: 03052427 Viton® P/N: 03051758

Performance

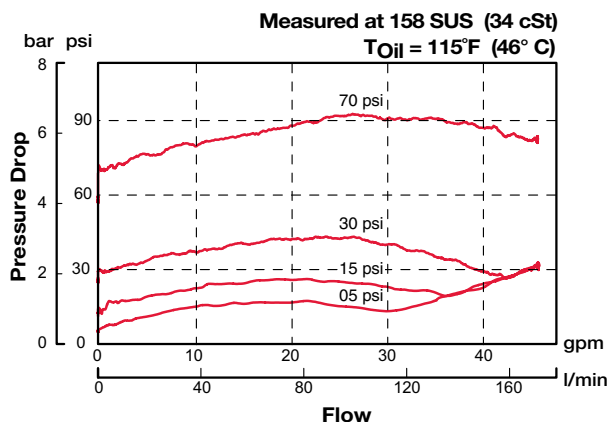

CHECK & LOAD CONTROL VALVES

Dimensions

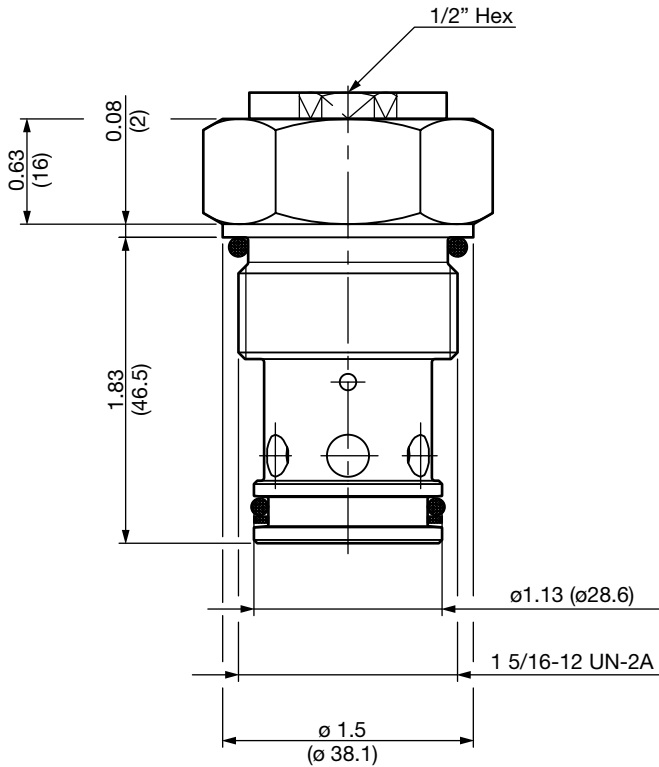
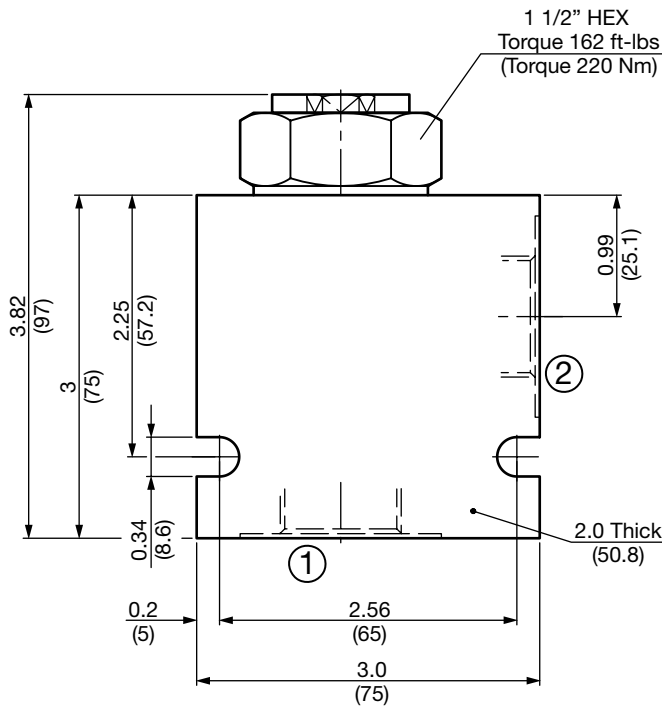

Model Code

RV16A-01-C-N-05

Valve Model

Body & Ports

- C = Cartridge only
- AS16 = SAE-16 Ports, aluminum Body
- SS16 = SAE-16 Ports, steel Body

Seals

- N = Buna-N
- V = Viton®

Cracking Pressure

- 05 = 5 psi (0.35 bar)
- 15 = 15 psi (1.00 bar)
- 30 = 30 psi (2.00 bar)
- 70 = 70 psi (5.00 bar)

All measurements in inches (mm).
Subject to technical modifications

Standard Line Bodies*

Code	Part No	Material	Pressure Rating	Weight
FH162-AS16	03037195	Aluminum, anodized	3500 psi (245 bar)	1.20 lb (0.55 kg)
FH162-SS16	03032655	Steel, Zinc plated	6000 psi (420 bar)	3.56 lb (1.62 kg)

*Please refer to Line Bodies & Cavities section for details

CHECK & LOAD CONTROL VALVES

RV06B-01

Check Valve, Integral Relief, Ball Type

Up to 4 gpm (15 l/min) • 5000 psi (350 bar)

Hydraulic Symbol

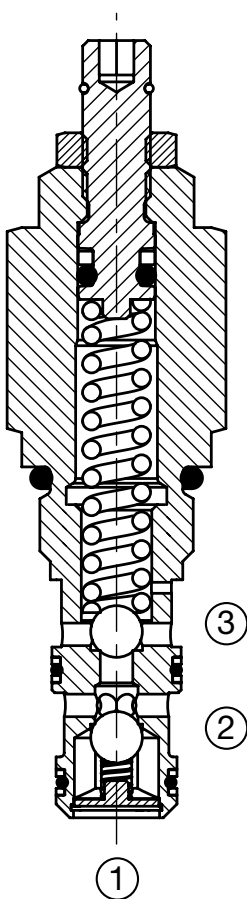
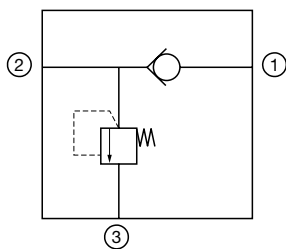

Description

A screw-in cartridge, ball type check valve and direct acting, ball type relief valve combined in a single cartridge intended for use as load holding and pressure limiting device in hydraulic circuits to reduce manifold size.

Operation

The RV06B allows flow from port 2 to port 1 once the sufficient pressure is applied at port 2 to overcome the bias spring pressure of 5 psi (0.34 bar). It normally blocks flow in the opposite direction.

The relief portion of the valve would remain closed until the predetermined pressure setting is reached at port 2 to lift the spring opposed ball from its seat, allowing flow from port 2 to port 3. Pressure at port 3 is directly additive to relief pressure setting.

Features

- Combination of two functions in one cartridge
- Relief setting up to 5000 psi (350 bar)
- Relief setting adjustment screw cannot be backed out of the valve
- Adjustable under full pressure
- Fast closing and seating
- Hardened closing elements to ensure minimal wear and extend service life
- All external surfaces zinc-plated

Specifications

Operating Pressure	5000 psi (350 bar)
Maximum Flow Rate	4 gpm (15 l/min)
Internal Leakage	5 drops/min maximum to 75% of nominal setting.
Relief Pressure Ranges	0 to 3000 psi (0 to 207 bar) 0 to 5000 psi (0 to 350 bar)
Reseat Pressure	80% of crack pressure
Check Valve Bias Spring Cracking Pressure	5 psi (0.34 bar)
Fluid Operating Temp. Range	-20° to 248°F (-29° to 120°C)
Fluid Compatibility	Mineral-Based or Synthetics with lubricating properties
Viscosity	50 to 2000 SUS (7.4 to 420 cSt)
Filtration	21/19/16 or cleaner per (ISO 4406)
Installation	No Orientation Restrictions
Cavity	FC06-3 (see <i>Line Bodies & Cavities</i> section)
Cavity Tools	Rougher: 02582050 Finisher: 02582051
Cartridge Weight	0.06 lb (27 g)
Cartridge Material	Steel with hardened work surfaces. Zinc plated exposed surfaces. Buna N or Viton® o-rings. Solid Thermoplastic Polyester back-up rings.
Seal Kits	Buna-N P/N: 02610186 Viton® P/N: 02610187

Performance – Relief

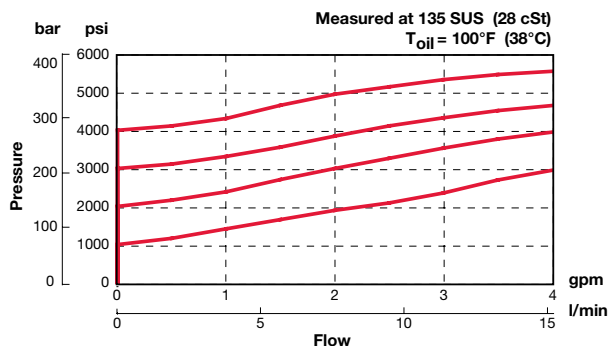

CHECK & LOAD CONTROL VALVES

Dimensions

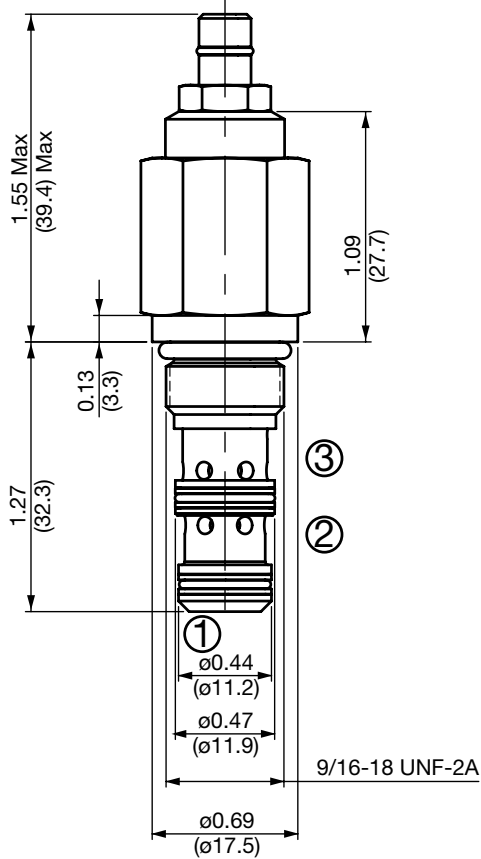
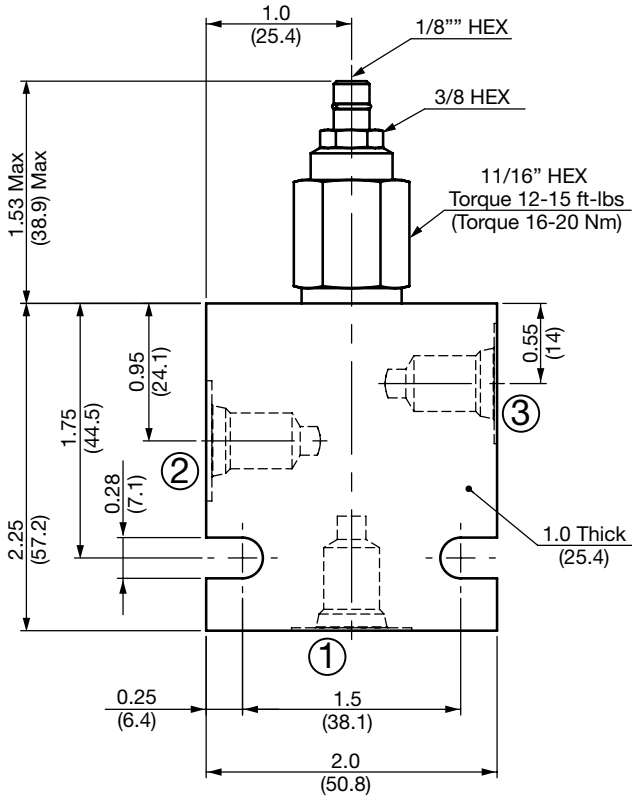

All measurements in inches (mm).
Subject to technical modifications

Model Code

RV06B-01-AS4-N-300 V 100

- Valve Model** _____
- Body & Ports** _____
- C = Cartridge only
 - AS4 = SAE-4 Ports, aluminum Body
 - SS4 = SAE-4 Ports, steel Body
- Seals** _____
- N = Buna-N
 - V = Viton®
- Relief Adjustment Range** _____
- 300 = 0 to 3000 psi (0 to 207 bar)
 - 500 = 0 to 5000 psi (0 to 350 bar)
- Relief Adjustment Options** _____
- V = Allen Head (Hex 1/8")
- Setting** _____
- blank = Set at 50% maximum pressure for the range
 - XXX = Desired psi \div 10
- Example: 100 = 1000 psi*

Performance – Check Valve

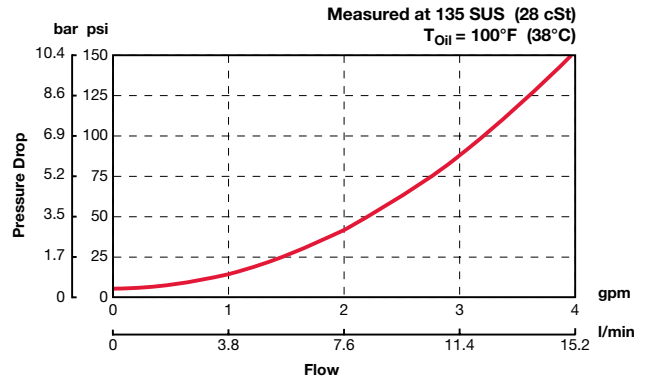

Standard Line Bodies*

Code	Part No	Material	Pressure Rating	Weight
FH063-AS4	02600492	Aluminum, anodized	3500 psi (245 bar)	0.36 lbs (0.16 kg)
FH063-SS4	02600493	Steel, Zinc plated	6000 psi (420 bar)	1.1 lbs (0.50 kg)

*Please refer to Line Bodies & Cavities section for details

CHECK & LOAD CONTROL VALVES

RV06C-01

Check Valve, Integral Relief, Poppet Type

Up to 5 gpm (19 l/min) • 5000 psi (350 bar)

Hydraulic Symbol

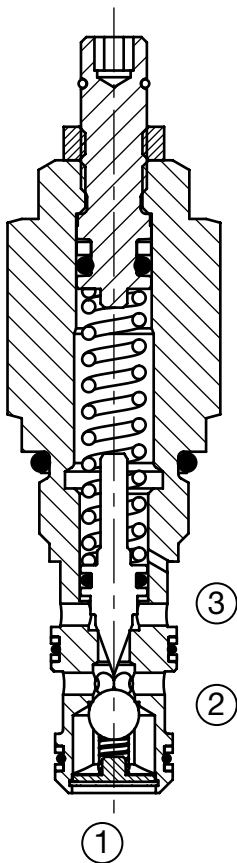
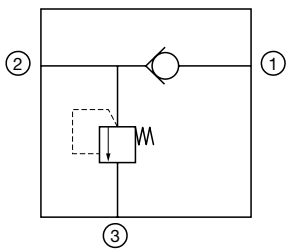

Description

A screw-in cartridge, ball type check valve and direct acting, poppet type relief valve combined in a single cartridge intended for use as load holding and pressure limiting device in hydraulic circuits to reduce manifold size.

Operation

The RV06C allows flow from port 2 to port 1 once the sufficient pressure is applied at port 2 to overcome the bias spring pressure of 5 psi (0.34 bar). It normally blocks flow in the opposite direction.

The relief portion of the valve would remain closed until the predetermined pressure setting is reached at port 2 to lift the spring opposed poppet from its seat, allowing flow from port 2 to port 3. Pressure at port 3 is directly additive to relief pressure setting.

Features

- Combination of two functions in one cartridge
- Relief setting up to 5000 psi (350 bar)
- Relief setting adjustment screw cannot be backed out of the valve
- Adjustable under full pressure
- Fast closing and seating
- Hardened closing elements to ensure minimal wear and extend service life
- All external surfaces zinc-plated

Specifications

Operating Pressure	5000 psi (350 bar)
Maximum Flow Rate	5 gpm (19 l/min)
Internal Leakage	5 drops/min maximum to 75% of nominal setting.
Relief Pressure Ranges	0 to 1800 psi (0 to 124 bar) 0 to 3000 psi (0 to 207 bar) 500 to 5000 psi (35 to 350 bar)
Reseat Pressure	80% of crack pressure
Check Valve Bias Spring Cracking Pressure	5 psi (0.34 bar)
Fluid Operating Temp. Range	-20° to 248°F (-29° to 120°C)
Fluid Compatibility	Mineral-Based or Synthetics with lubricating properties
Viscosity	50 to 2000 SUS (7.4 to 420 cSt)
Filtration	21/19/16 or cleaner per (ISO 4406)
Installation	No orientation restrictions
Cavity	FC06-3 (see <i>Line Bodies & Cavities</i> section)
Cavity Tools	Rougher: 02582050 Finisher: 02582051
Cartridge Weight	0.06 lb (27 g)
Cartridge Material	Steel with hardened work surfaces. Zinc plated exposed surfaces. Buna N or Viton® o-rings. Solid thermoplastic polyester back-up rings.
Seal Kits	Buna-N P/N: 02610186 Viton® P/N: 02610187

Performance – Relief

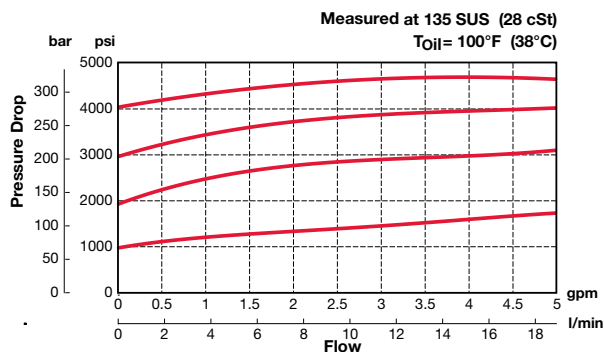

CHECK & LOAD CONTROL VALVES

Dimensions

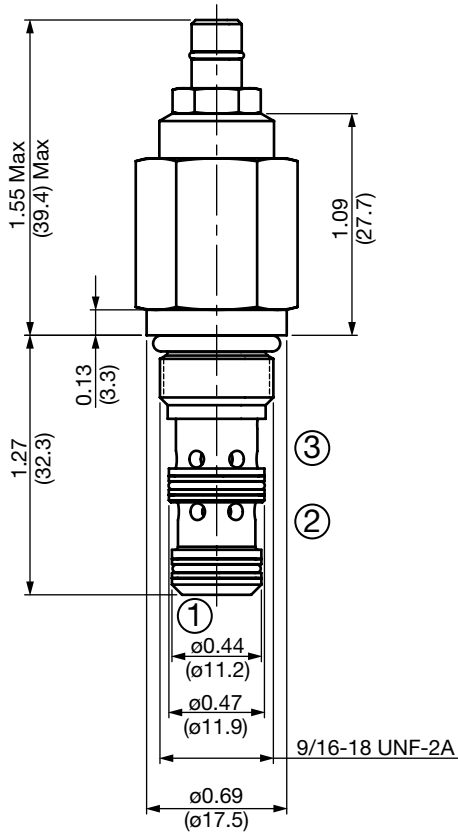
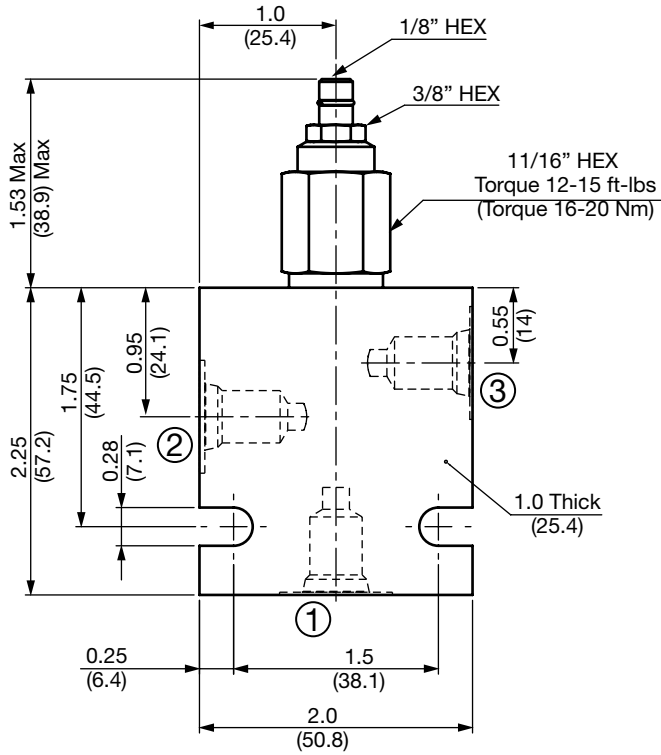

All measurements in inches (mm).
Subject to technical modifications

Model Code

RV06C-01-AS4-N-180 V 100

Valve Model	RV06C-01-AS4-N-180 V 100
Body & Ports	C = Cartridge only AS4 = SAE-4 Ports, aluminum Body SS4 = SAE-4 Ports, steel Body
Seals	N = Buna-N V = Viton®
Relief Adjustment Range	180 = 0 to 1800 psi (0 to 124 bar) 300 = 0 to 3000 psi (0 to 207 bar) 500 = 500 to 5000 psi (35 to 350 bar)
Relief Adjustment Options	V = Allen Head (Hex 1/8")
Setting	blank = Set at 50% maximum pressure for the range XXX = Desired psi ÷ 10 Example: 100 = 1000 psi

Performance – Check Valve

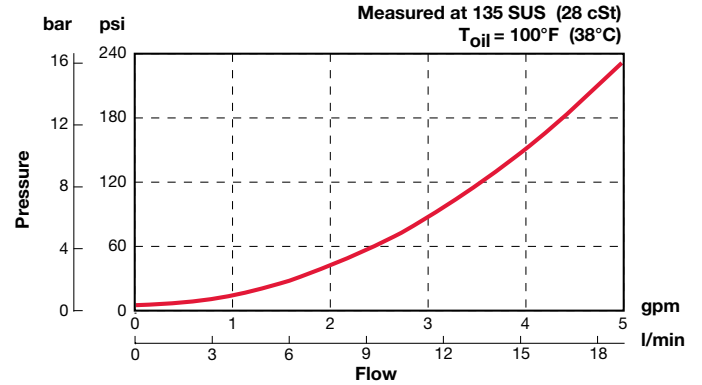

Standard Line Bodies*

Code	Part No	Material	Pressure Rating	Weight
FH063-AS4	02600492	Aluminum, anodized	3500 psi (245 bar)	0.36 lbs (0.16 kg)
FH063-SS4	02600493	Steel, Zinc plated	6000 psi (420 bar)	1.1 lbs (0.50 kg)

*Please refer to Line Bodies & Cavities section for details

CHECK & LOAD CONTROL VALVES

RVD08A-01

Check Valve, Dual Pilot-to-Open, Inline Body

Up to 10 gpm (38 l/min) • 6000 psi (420 bar)

Hydraulic Symbol

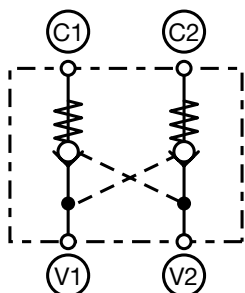

Description

An inline housed, dual pilot operated, hydraulic check valve for use as a blocking or load holding device. The valve consists of two check valves and a dual pilot piston in an inline body.

Operation

The RVD08A allows flow from V ports to C ports, while normally blocking flow in the opposite direction. Flow will be allowed from C to V when pressure is applied at the opposite V port.

The check is spring biased at 30 psi to assure holding in no load conditions. A sealed pilot piston option with check spring bias of 70 psi is available.

Features

- Hardened closing element in a check valve to ensure extended service life and low leakage
- Multiple bias spring options for back pressure application flexibility
- Optional sealed pilot piston
- Check section serviceable as a cartridge
- All external surfaces zinc-plated
- Aluminum and steel inline housing

Specifications

Operating Pressure	6000 psi (420 bar) - Steel body 3500 psi (245 bar) - Aluminum body	
Nominal Flow	10 gpm (38 l/min)	
Internal Leakage	<2 drops/min. at 6000 psi (0.10 cc/min at 420 bar)	
Standard Cracking Pressures	30 psi (2.00 bar) 70 psi (5.00 bar)	
Pilot Ratio	4.5 to 1	
Fluid Operating Temp. Range*	-4° to 248°F (-20° to +120°C) (Consult factory for usage at temp. outside range.)	
Fluid Compatibility	Mineral-based or synthetics with lubricating properties	
Viscosity	50 to 2000 SUS (7.4 to 420 cSt)	
Filtration	21/19/16 or cleaner (per ISO 4406). Use with filter rated $\beta_{10} \geq 200$.	
Installation	No orientation restrictions	
Cartridge Weight	1.33 Lbs. (0.61 kg) Aluminum 3.3 Lbs. (1.5 kg) Steel	
Cartridge Material	Steel with hardened work surfaces. Zinc-plated exposed surfaces. Buna N or Viton® o-rings. PTFE back-up rings.	
Pilot Piston Material	Hardened steel	
Pilot Piston Service Part Numbers	Standard Piston Assy:	02610072
	Sealed Piston Assy (Buna-N):	02610071
	Sealed Piston Assy (Viton®):	02610070
	Piston Only:	02600019
Seal Kits (for RV08A)	Buna-N	FS082-N P/N: 03033920
	Viton®	FS082-V P/N: 03051756
Seal Kits (Pilot Piston)	Buna-N	P/N: 02610078
	Viton®	P/N: 02610079
PTFE wiper ring (for std piston)	02600006	

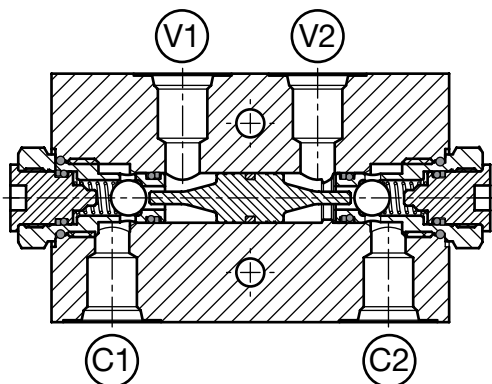

Performance

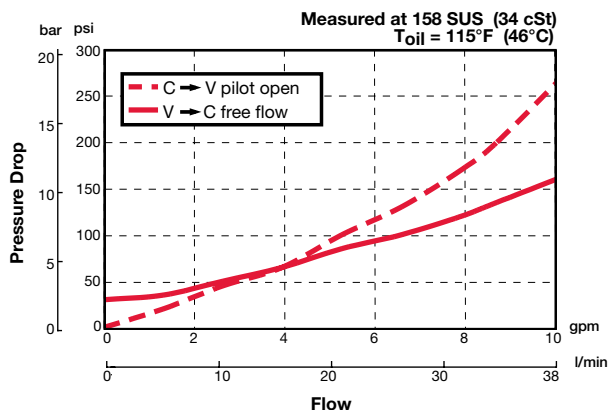

CHECK & LOAD CONTROL VALVES

Dimensions

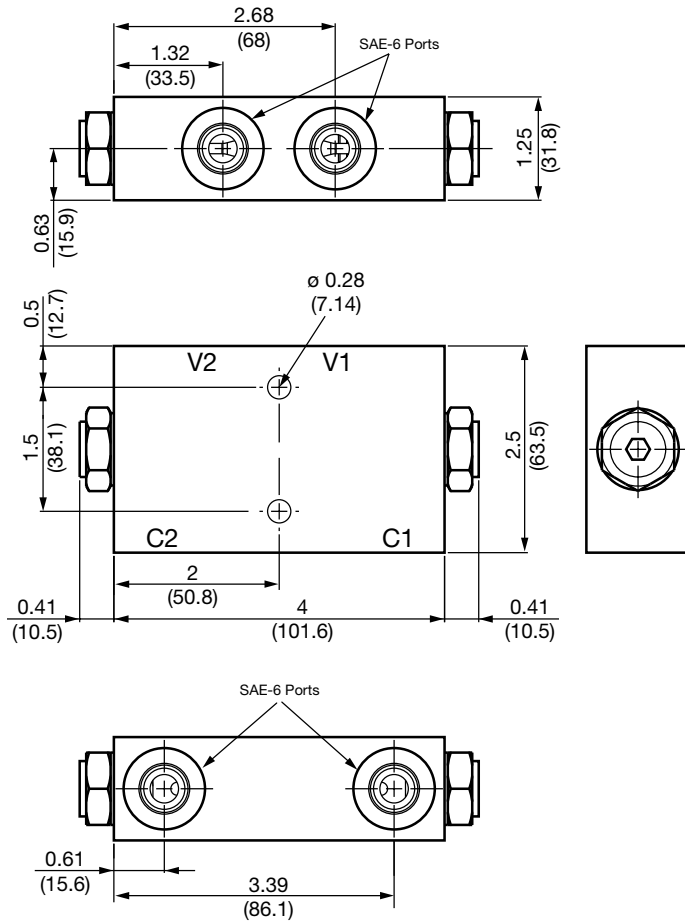

Model Code

RVD08A-01-AS6-N-30

Valve Model

Body & Ports

- AS6 = SAE-6 Ports, aluminum Body
- SS6 = SAE-6 Ports, steel Body

Seals

- N = Buna-N
- V = Viton®
- NS = Buna-N with Sealed Piston (Requires 70 psi spring)
- VS = Viton® with Sealed Piston (Requires 70 psi spring)

Cracking Pressure

- 30 = 30 psi (2.00 bar)
- 70 = 70 psi (5.00 bar)

Pilot Piston Assembly

- Standard Options **N, V** = P/N: 02610072
- Sealed **NS** Option = P/N: 02610070
- Sealed **VS** Option = P/N: 02610071

All measurements in inches (mm).
Subject to technical modifications

Standard Line Bodies*

Code	Part No	Material	Pressure Rating	Weight
AS6	02600014	Aluminum, anodized	3500 psi (245 bar)	1.02 lb (0.47 kg)
SS6	02600015	Steel, Zinc plated	6000 psi (420 bar)	3.0 lb (1.36 kg)

*Please refer to Line Bodies & Cavities section for details

CHECK & LOAD CONTROL VALVES

RVD10A-01

Check Valve, Dual Pilot-to-Open, Inline Body

Up to 21 gpm (80 l/min) • 6000 psi (420 bar)

Hydraulic Symbol

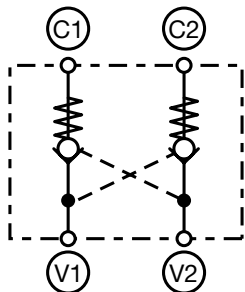

Description

An inline housed, dual pilot operated, hydraulic check valve for use as a blocking or load holding device. The valve consists of two check valves and a dual pilot piston in an inline body.

Operation

The RVD10A allows flow from V ports to C ports, while normally blocking flow in the opposite direction. Flow will be allowed from C to V when pressure is applied at the opposite V port.

The check is spring biased at 30 psi to assure holding in no load conditions. A sealed pilot piston option with check spring bias of 70 psi is available.

Features

- Hardened closing element in a check valve to ensure extended service life and low leakage
- Multiple bias spring options for back pressure application flexibility
- Optional sealed pilot piston
- Check section serviceable as a cartridge
- All external surfaces zinc-plated
- Aluminum and steel inline housing

Specifications

Operating Pressure	6000 psi (420 bar) - Steel body 3500 psi (245 bar) - Aluminum body		
Nominal Flow	21 gpm (80 l/min)		
Internal Leakage	<2 drops/min. at 6000 psi (0.10 cc/min at 420 bar)		
Standard Bias Spring Pressures	30 psi (2.00 bar) 70 psi (5.00 bar)		
Pilot Ratio	4.5 to 1		
Fluid Operating Temp. Range	-4° to 248°F (-20° to +120°C) (Consult factory for usage at temp. outside range.)		
Fluid Compatibility	Mineral-based or synthetics with lubricating properties		
Viscosity	50 to 2000 SUS (7.4 to 420 cSt)		
Filtration	21/19/16 or cleaner (per ISO 4406). Use with filter rated $\beta_{10} \geq 200$.		
Installation	No orientation restrictions		
Cartridge Weight	1.54 Lbs. (0.7 kg) Aluminum		
Cartridge Material	Steel with hardened work surfaces. Zinc-plated exposed surfaces. Buna N or Viton® o-rings. PTFE back-up rings.		
Pilot Piston Material	Hardened Steel		
Pilot Piston Service Part Numbers	Standard Piston Assy:	02610066	
	Sealed Piston Assy (Buna-N):	02610064	
	Sealed Piston Assy (Viton®):	02610065	
	Piston Only:	02600003	
Seal Kits (for RV10A)	Buna-N	FS102-N	P/N: 03033872
	Viton®	FS102-V	P/N: 03051757
Seal Kits (Pilot Piston)	Buna-N	P/N: 02610076	
	Viton®	P/N: 02610077	
PTFE wiper ring (for std piston)	02600008		

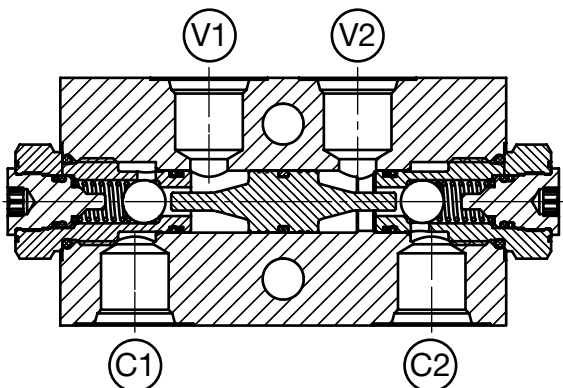

Performance

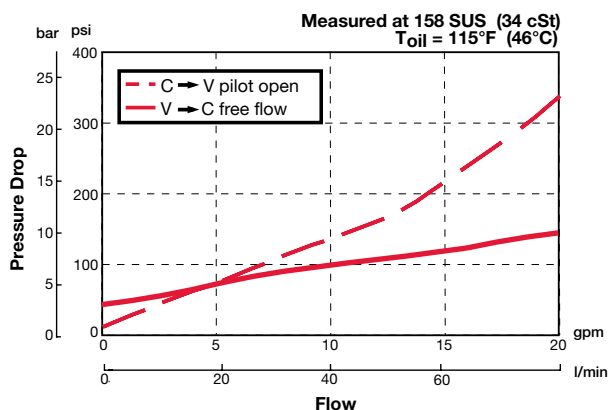

CHECK & LOAD CONTROL VALVES

Dimensions

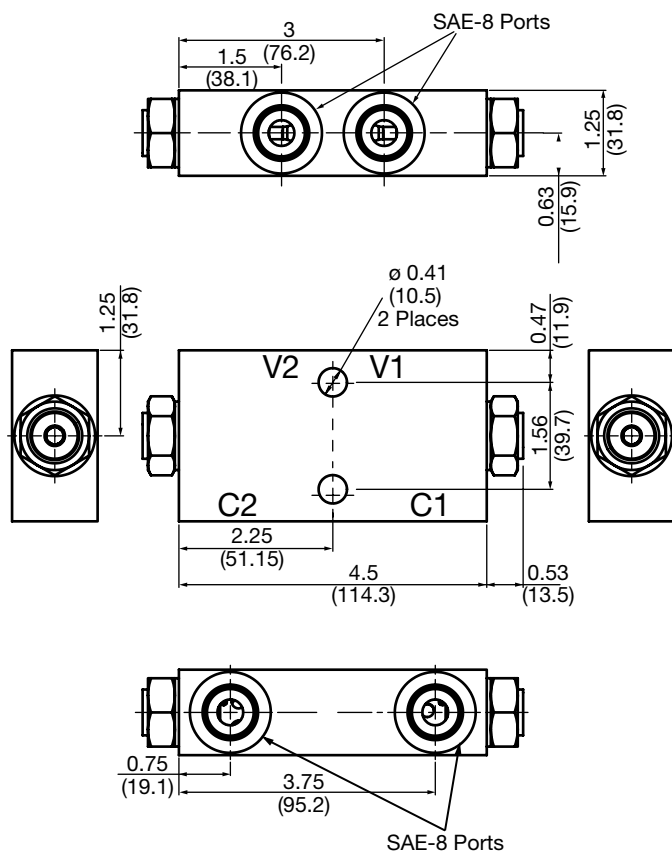

Model Code

RVD10A-01-AS8-N-30

- Valve Model** _____
- Body & Ports** _____
- AS8 = SAE-8 Ports, aluminum Body
 - SS8 = SAE-8 Ports, steel Body
- Seals** _____
- N = Buna-N
 - V = Viton®
 - NS = Buna-N with Sealed Piston (Requires 70 psi spring)
 - VS = Viton® with Sealed Piston (Requires 70 psi spring)
- Cracking Pressure** _____
- 30 = 30 psi (2.00 bar)
 - 70 = 70 psi (5.00 bar)

Pilot Piston Assembly

- Standard Options **N, V** = P/N: 02610066
- Sealed **NS** Option = P/N: 02610064
- Sealed **VS** Option = P/N: 02610065

All measurements in inches (mm).
Subject to technical modifications

Standard Line Bodies*

Code	Part No	Material	Pressure Rating	Weight
AS8	02600004	Aluminum, anodized	3500 psi (245 bar)	1.03 lb (0.47 kg)
SS8	02600005	Steel, Zinc plated	6000 psi (420 bar)	3.02 lb (1.37 kg)

*Please refer to Line Bodies & Cavities section for details

CHECK & LOAD CONTROL VALVES

RVS08A-01

Check Valve, Single Pilot-to-Open, Inline Body

Up to 10 gpm (38 l/min) • 6000 psi (420 bar)

Hydraulic Symbol

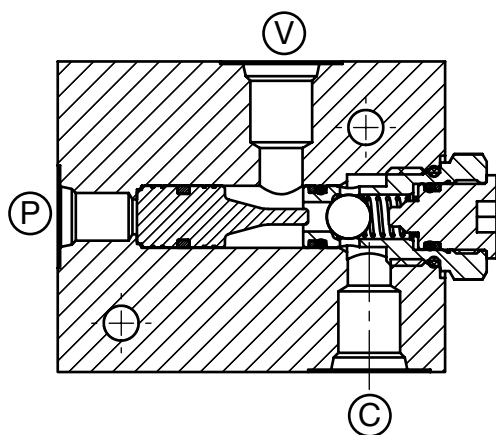
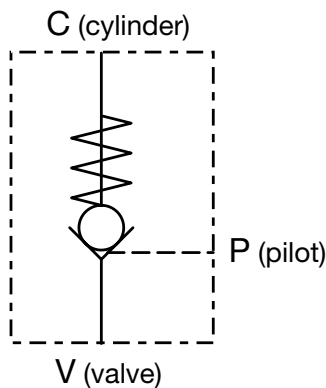

Description

An inline housed, pilot operated, hydraulic check valve for use as a blocking or load holding device.

Operation

The RVS08A allows flow from port V to port C, while normally blocking flow in the opposite direction. Flow will be allowed from C to V when pressure is applied at pilot port P.

The check is spring biased at 30 psi to assure holding in no load conditions. A sealed pilot piston option with check spring bias of 70 psi is available.

Features

- Hardened closing element in a check valve to ensure extended service life and low leakage
- Multiple bias spring options for back pressure application flexibility
- Optional sealed pilot piston
- Check section serviceable as a cartridge
- All external surfaces zinc-plated
- Aluminum and steel inline housing

Specifications

Operating Pressure	6000 psi (420 bar) - Steel body 3500 psi (245 bar) - Aluminum body		
Nominal Flow	10 gpm (38 l/min)		
Internal Leakage	<2 drops/min. at 6000 psi (0.10 cc/min at 420 bar)		
Standard Cracking Pressures	30 psi (2.00 bar) 70 psi (5.00 bar)		
Pilot Ratio	4.5 to 1		
Fluid Operating Temp. Range	-4° to 248°F (-20° to +120°C) <i>(Consult factory for usage at temp. outside range.)</i>		
Fluid Compatibility	Mineral-based or synthetics with lubricating properties		
Viscosity	50 to 2000 SUS (7.4 to 420 cSt)		
Filtration	21/19/16 or cleaner (per ISO 4406). Use with filter rated $\beta_{10} \geq 200$.		
Installation	No orientation restrictions		
Cartridge Weight	1.0 Lbs. (0.45 kg) Aluminum 2.6 Lbs. (1.18 kg) Steel		
Cartridge Material	Steel with hardened work surfaces. Zinc-plated exposed surfaces. Buna N or Viton® o-rings. PTFE back-up rings.		
Pilot Piston Material	Hardened steel		
Pilot Piston Service Part Numbers	Standard Piston Assy:	02610069	
	Sealed Piston Assy (Buna-N):	02610067	
	Sealed Piston Assy (Viton®):	02610068	
	Piston Only:	02600016	
Seal Kits (for RV08A)	Buna-N	FS082-N	P/N: 03033920
	Viton®	FS082-V	P/N: 03051756
Seal Kits (Pilot Piston)	Buna-N	P/N: 02610078	
	Viton®	P/N: 02610079	
PTFE wiper ring (for std piston)	02600006		

Performance

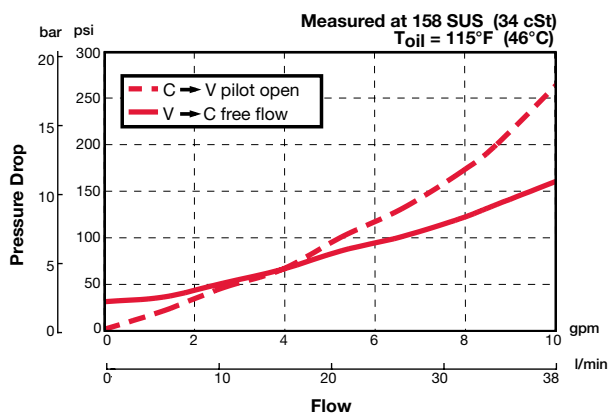

CHECK & LOAD CONTROL VALVES

Dimensions

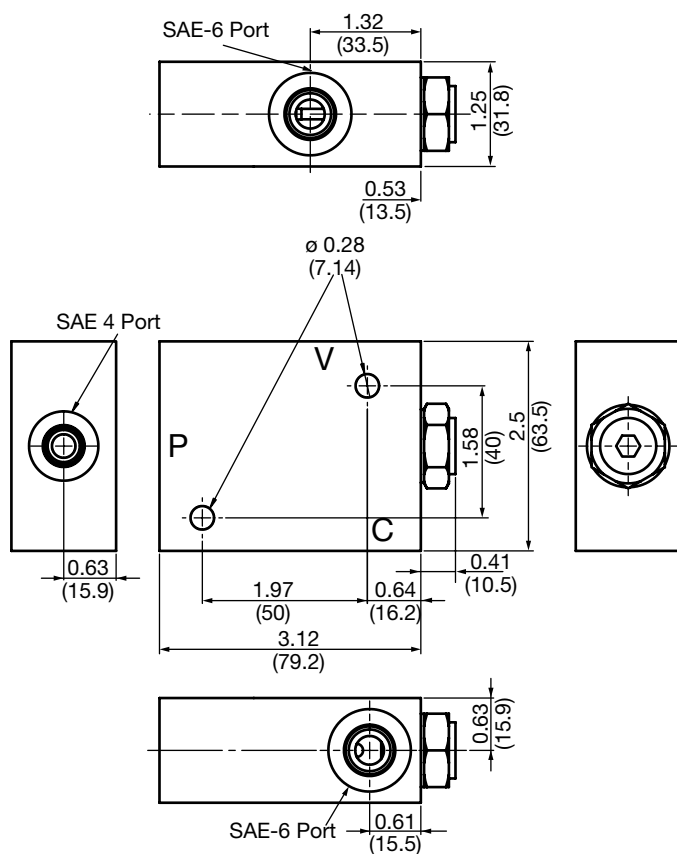

Model Code

RVS08A-01-AS6-N-30

Valve Model

Body & Ports

- AS6 = SAE-6 Ports, aluminum Body
- SS6 = SAE-6 Ports, steel Body
- (Pilot Port = SAE-4)

Seals

- N = Buna-N
- V = Viton®
- NS = Buna-N with Sealed Piston (Requires 70 psi spring)
- VS = Viton® with Sealed Piston (Requires 70 psi spring)

Cracking Pressure

- 30 = 30 psi (2.00 bar)
- 70 = 70 psi (5.00 bar)

Pilot Piston Assembly

- Standard Options **N, V** = P/N: 02610069
- Sealed **NS** Option = P/N: 02610067
- Sealed **VS** Option = P/N: 02610068

All measurements in inches (mm).
Subject to technical modifications

Standard Line Bodies*

Code	Part No	Material	Pressure Rating	Weight
AS6	02600010	Aluminum, anodized	3500 psi (245 bar)	0.83 lb (0.38 kg)
SS6	02600011	Steel, Zinc plated	6000 psi (420 bar)	2.42 lb (1.1 kg)

*Please refer to Line Bodies & Cavities section for details

CHECK & LOAD CONTROL VALVES

RVS10A-01

Check Valve, Single Pilot-to-Open, Inline Body

Up to 21 gpm (80 l/min) • 6000 psi (420 bar)

Hydraulic Symbol

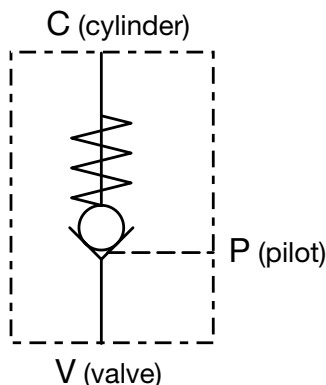

Description

An inline housed, pilot operated, hydraulic check valve for use as a blocking or load holding device.

Operation

The RVS10A allows flow from port V to port C, while normally blocking flow in the opposite direction. Flow will be allowed from C to V when pressure is applied at pilot port P.

The check is spring biased at 30 psi to assure holding in no load conditions. A sealed pilot piston option with check spring bias of 70 psi is available.

Features

- Hardened closing element in a check valve to ensure extended service life and low leakage
- Multiple bias spring options for back pressure application flexibility
- Optional sealed pilot piston
- Check section serviceable as a cartridge
- All external surfaces zinc-plated
- Aluminum and steel inline housing

Specifications

Operating Pressure	6000 psi (420 bar) - Steel body 3500 psi (245 bar) - Aluminum body	
Nominal Flow	21 gpm (80 l/min)	
Internal Leakage	<2 drops/min. at 6000 psi (0.10 cc/min at 420 bar)	
Standard Cracking Pressures	30 psi (2.00 bar) 70 psi (5.00 bar)	
Pilot Ratio	4.5 to 1	
Fluid Operating Temp. Range	-4° to 248°F (-20° to +120°C) <i>(Consult factory for usage at temp. outside range.)</i>	
Fluid Compatibility	Mineral-based or synthetics with lubricating properties	
Viscosity	50 to 2000 SUS (7.4 to 420 cSt)	
Filtration	21/19/16 or cleaner (per ISO 4406). Use with filter rated $\beta_{10} \geq 200$.	
Installation	No orientation restrictions	
Cartridge Weight	1.17 Lbs. (0.53 kg) Aluminum 2.88 Lbs. (1.31 kg) Steel	
Cartridge Material	Steel with hardened work surfaces. Zinc-plated exposed surfaces. Buna N or Viton® o-rings. PTFE back-up rings.	
Pilot Piston Material	Hardened steel	
Pilot Piston Service Part Numbers	Standard Piston Assy:	02610075
	Sealed Piston Assy (Buna-N):	02610073
	Sealed Piston Assy (Viton®):	02610074
	Piston Only:	02600000
Seal Kits (for RV08A)	Buna-N	FS082-N P/N: 03033872
	Viton®	FS082-V P/N: 03051757
Seal Kits (Pilot Piston)	Buna-N	P/N: 02610076
	Viton®	P/N: 02610077
PTFE wiper ring (for std piston)	02600028	

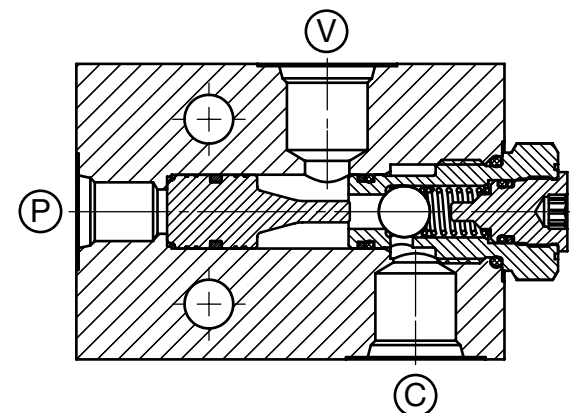

Performance

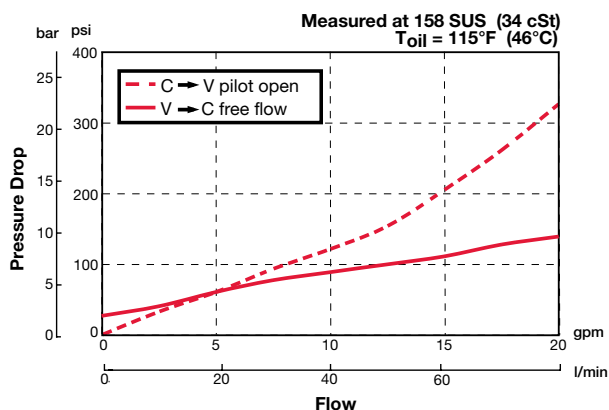

CHECK & LOAD CONTROL VALVES

Dimensions

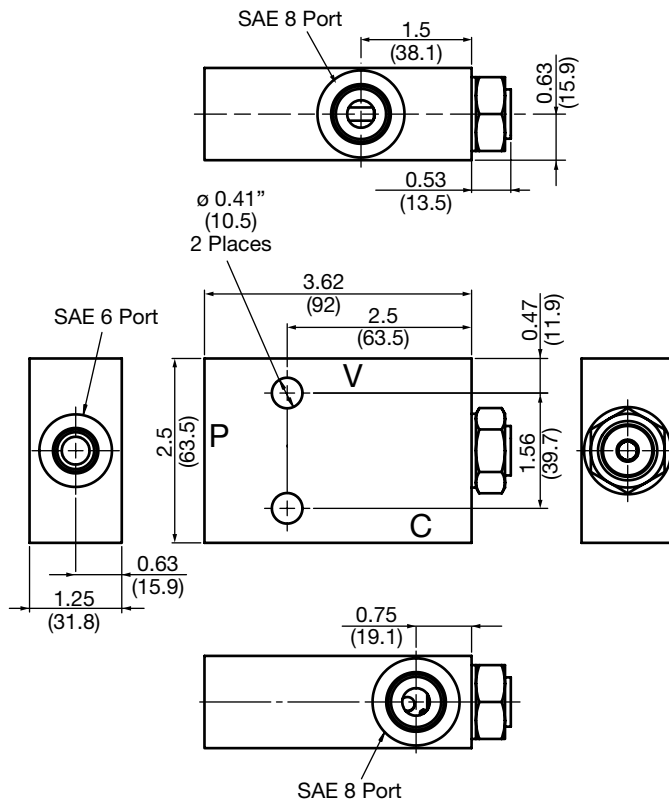

Model Code

RVS10A-01-AS8-N-30

Valve Model

Body & Ports

- AS8 = SAE-8 Ports, aluminum Body
- SS8 = SAE-8 Ports, steel Body
- (Pilot Port = SAE-6)

Seals

- N = Buna-N
- V = Viton®
- NS = Buna-N with Sealed Piston (Requires 70 psi spring)
- VS = Viton® with Sealed Piston (Requires 70 psi spring)

Cracking Pressure

- 30 = 30 psi (2.00 bar)
- 70 = 70 psi (5.00 bar)

Pilot Piston Assembly

- Standard Options **N, V** = P/N: 02610075
- Sealed **NS** Option = P/N: 02610073
- Sealed **VS** Option = P/N: 02610074

All measurements in inches (mm).
Subject to technical modifications

Standard Line Bodies*

Code	Part No	Material	Pressure Rating	Weight
AS8	02600001	Aluminum, anodized	3500 psi (245 bar)	0.88 lb (0.40 kg)
SS8	02600002	Steel, Zinc plated	6000 psi (420 bar)	2.6 lb (1.18 kg)

*Please refer to Line Bodies & Cavities section for details

CHECK & LOAD CONTROL VALVES

RS08-01

Counterbalance Valve

Up to 10 gpm (38 l/min) • 5000 psi (350 bar)

Hydraulic Symbol

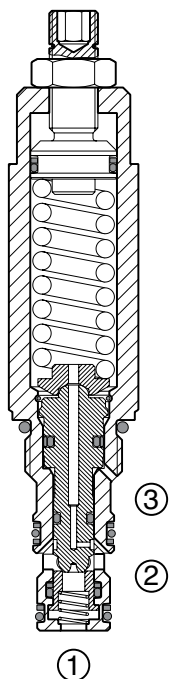
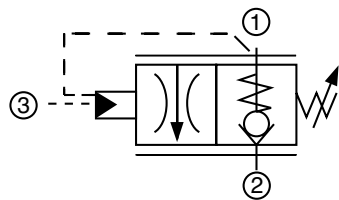

Description

A screw-in cartridge, 3-port, externally piloted counterbalance valve for precise control of overrunning loads, with load holding capabilities, thermal relief protection and free reverse flow check features.

Operation

The RS08 allows free flow from port 2 (inlet) to port 1 (load). Flow from port 1 to port 2 is blocked until either the pressure setting has been reached or sufficient pilot pressure has been applied to port 3 (pilot). The RS08 has optional 3:1 and 4:1 pilot ratios. It will open when pilot pressure = 1/3 (or 1/4) of the difference between the set pressure and the load pressure.

Features

- Excellent stability through entire flow range
- Adjustable across specified pressure range
- Positive stop prevents spring from over adjustment (options V, H)
- Stroke limiting device for enhanced safety
- Internal seals to minimize leakage
- Same cavity as the RP08A-01 P.O. Check valve.
- Hardened poppet and seat to ensure extended service life and low leakage
- All external surfaces zinc-plated
- Industry common cavity

Specifications

Operating Pressure	5000 psi (350 bar)
Nominal Flow	10 gpm (38 l/min)
Internal Leakage	5 drops/min. (0.25 cc/min) max. to 80% of nominal settings
Pilot Ratios	3:1, 4:1
Check Valve Cracking Pressure	14 psi (1.0 bar)
Fluid Operating Temp. Range	-4° to 248°F (-20° to +120°C) (Consult factory for usage at temp. outside range.)
Fluid Compatibility	Mineral-based or synthetics with lubricating properties
Viscosity	50 to 2000 SUS (7.4 to 420 cSt)
Filtration	21/19/16 or cleaner (per ISO 4406). Use with filter rated $\beta_{10} \geq 200$.
Installation	No orientation restrictions
Cavity	FC08-3 (see Line Bodies & Cavities section)
Cavity Tools	Rougher: 02580086 Finisher: 02580087
Cartridge Weight	0.58 Lbs. (.266 kg)
Cartridge Material	Steel with hardened work surfaces. Zinc-plated exposed surfaces. Anodized aluminum knobs. (option H) Buna N or Viton® o-rings, and PTFE back-up rings.
Seal Kits	Buna-N P/N: 03054795 Viton® P/N: 02591059

Performance

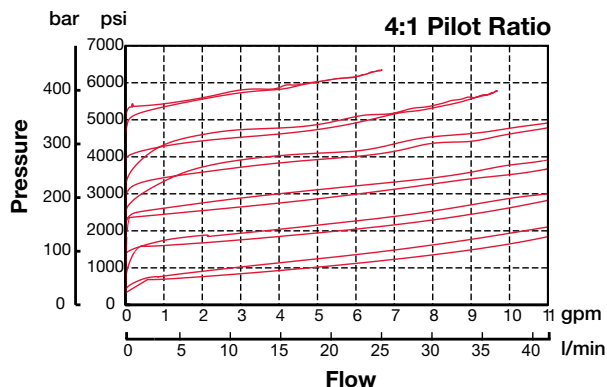
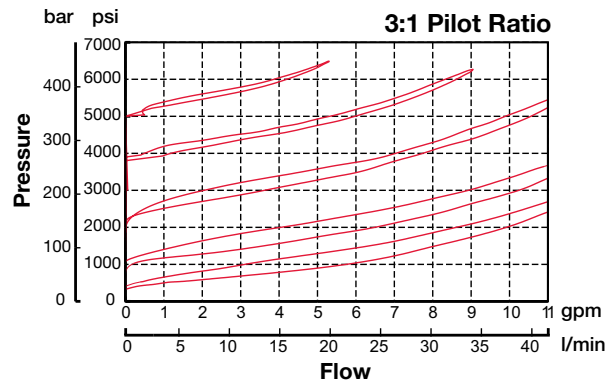

CHECK & LOAD CONTROL VALVES

Dimensions

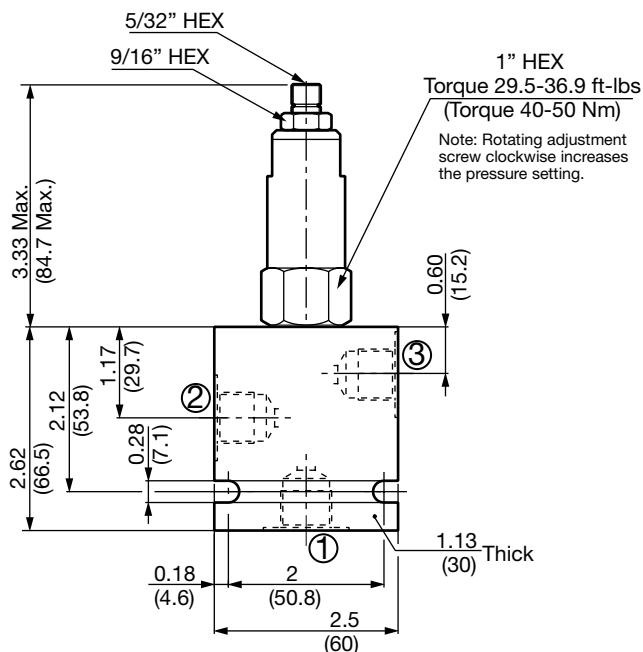

Model Code

RS08-01-C-N-3-500 V 300

Valve Model	_____
Body & Ports	_____
C	= Cartridge only
AS6	= SAE-6 ports, aluminum body
SS6	= SAE-6 ports, steel body
Seals	_____
N	= Buna-N
V	= Viton®
Pilot Ratio	_____
3	= 3:1
4	= 4:1
Adjustment Range	_____
500	= 700 to 5000 psi (48 to 350 bar)
Adjustment Options	_____
F	= Factory pre-set, non-adjustable (must specify setting below)
H	= Knurled Hand Knob
K	= Allen Head (HEX 5/32") w/ cover cap
V	= Allen Head (HEX 5/32")
Setting (optional)	_____
(omit)	= Set at min. pressure for the range
XXX	= Desired psi ÷ 10
Example: 300 = 3000 psi	

Adjustment Options

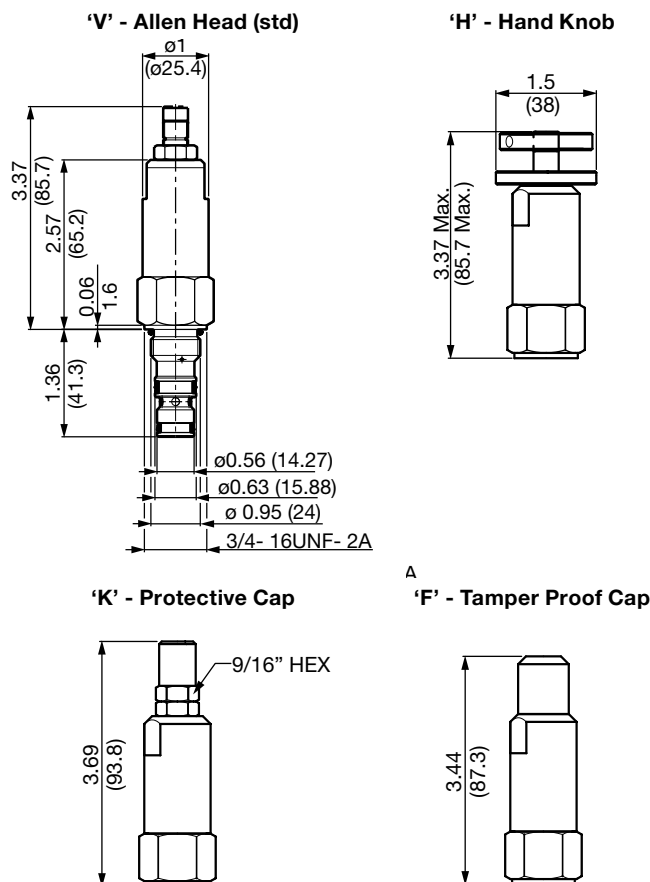

Performance

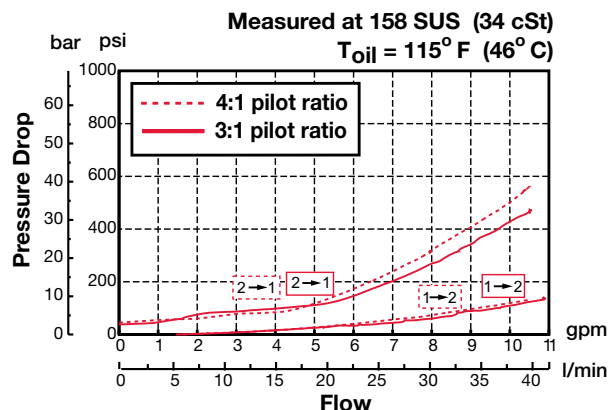

All measurements in inches (mm).
Subject to technical modifications

Standard Line Bodies*

Code	Part No	Material	Pressure Rating	Weight
FH083-AS6	03011424	Aluminum, anodized	3500 psi (245 bar)	0.58 lb (0.26 kg)
FH083-SS6	00560920	Steel, Zinc plated	6000 psi (420 bar)	1.70 lb (0.77 kg)

*Please refer to Line Bodies & Cavities section for details

E1

Overview

HYDAC offers various options of Differential Pressure Sensing Valves for applications up to 5000 psi (350 bar) and up to 80 gpm(300 l/min).

Differential pressure sensing valves can be used for controlling pressure, flow, direction or compensation. They are functional building elements which respond to pressure inputs, providing for switching or modulation of the flow. The choice of circuit arrangements related to the Pressure Sensing valves can simplify the circuit design and minimize the size of the manifold, thus reducing manifold cost.

Features

- Operating pressure up to 5000 psi (350 bar)
- Various spring ranges
- Quiet, modulated response
- All external surfaces zinc-plated
- Hardened spool and sleeve to ensure minimal wear and extend service life
- Industry common cavity



PRESSURE SENSING VALVES

DW10SA-01

Normally Closed, Vent to Open, Spool Type

Up to 40 gpm (151 lpm) • 5000 psi (350 bar)

Hydraulic Symbol

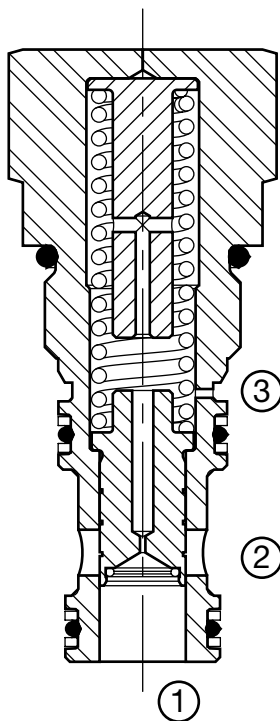
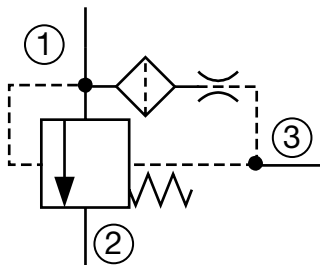

Description

A screw-in cartridge, pressure sensing valve with multifunction potential when used with flow, pressure and directional control devices. It can be used as high flow switching or metering element, main stage for pilot operated relief or sequence valve.

Operation

Pilot flow through the spool orifice, from port 1 to port 3 creates a pressure drop and allows flow from port 1 to port 2 when the pressure drop exceeds the spring bias pressure. The valve can be remotely controlled at port 3 such as relief or solenoid valve.

Features

- Operating pressure up to 5000 psi (350 bar)
- Various bias spring settings up to 300 psi (20.7 bar)
- Quiet, modulated response
- All external surfaces zinc-plated
- Hardened spool and sleeve to ensure minimal wear and extend service life
- Industry common cavity

Specifications

Operating Pressure	5000 psi (350 bar)
Nominal Flow	40 gpm (151 l/min)
Internal Leakage	30.5 cu in/min at 5000 psi (0.5 l/min at 350 bar)
Fluid Operating Temp. Range	-20° to 248°F (-29° to 120°C)
Fluid Compatibility	Mineral-based or synthetics with lubricating properties
Viscosity	50 to 2000 SUS (7.4 to 420 cSt)
Filtration	21/19/16 or cleaner per (ISO 4406)
Installation	No orientation restrictions
Cavity	FC10-S3 (see <i>Line Bodies & Cavities</i> section)
Cavity Tools	Rougher: 02581794 Finisher: 02581795
Cartridge Weight	0.35 lb (0.158 kg)
Cartridge Material	Steel with hardened work surfaces. Zinc plated exposed surfaces. Buna N or Viton® o-rings. Solid thermoplastic polyester back-up rings.
Seal Kits	Buna-N FS10S3-N P/N: 02610278 Viton® FS10S3-V P/N: 02610279
Vent Flow Rate	Approximately 0.15 gpm (0.57 lpm)

Performance

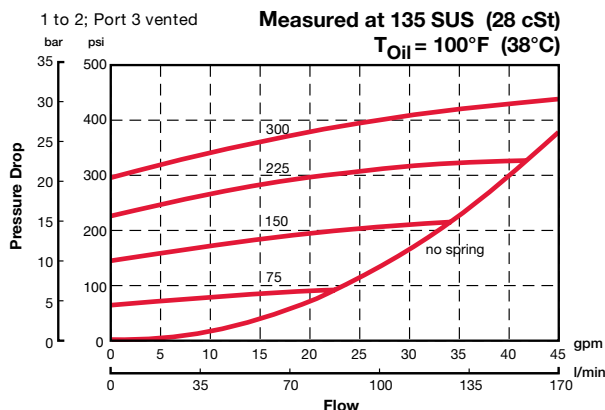

Application

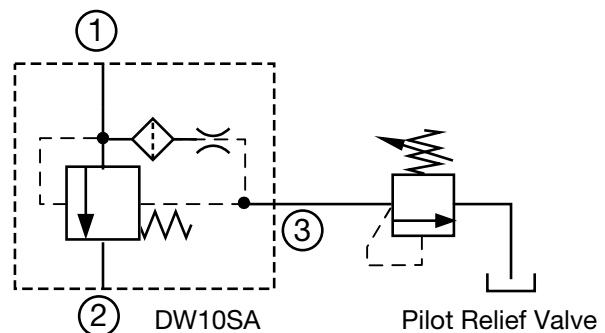

Pressure Relief / Sequence Application

PRESSURE SENSING VALVES

Dimensions

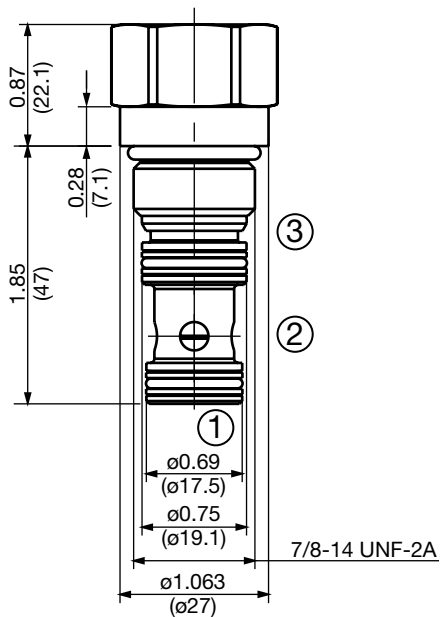
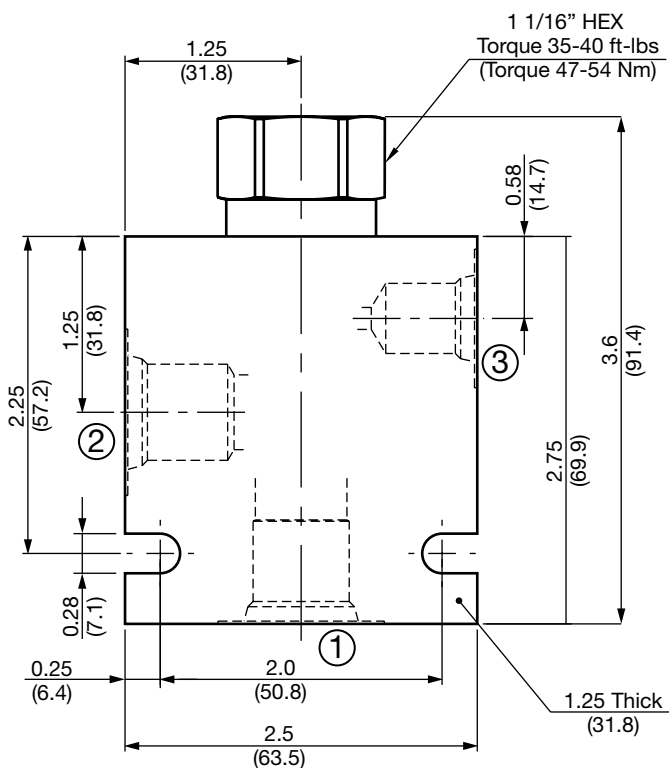

Model Code

DW10SA-01-AS8-N-300

Valve Model

Body & Ports

- C = Cartridge only
 - AS8 = SAE-8 Ports, aluminum Body
 - SS8 = SAE-8 Ports, steel Body
- (Pilot Port = SAE-6)

Seals

- N = Buna-N
- V = Viton®

Bias Spring

- 75 = 75 psi
- 150 = 150 psi
- 225 = 225 psi
- 300 = 300 psi

All measurements in inches (mm).
Subject to technical modifications

PN#02087369 / 10.19 / CHD1110-1389

Standard Line Bodies*

Code	Part No	Material	Pressure Rating	Weight
FH10S3-AS8	02582076	Aluminum, anodized	3500 psi (245 bar)	0.59 lbs (0.27 kg)
FH10S3-SS8	02582077	Steel, zinc plated	6000 psi (420 bar)	1.67 lbs (0.76 kg)

*Please refer to Line Bodies & Cavities section for details

PRESSURE SENSING VALVES

DW16SA-01

Normally Closed, Vent to Open, Spool Type

Up to 75 gpm (285 lpm) • 5000 psi (350 bar)

Hydraulic Symbol

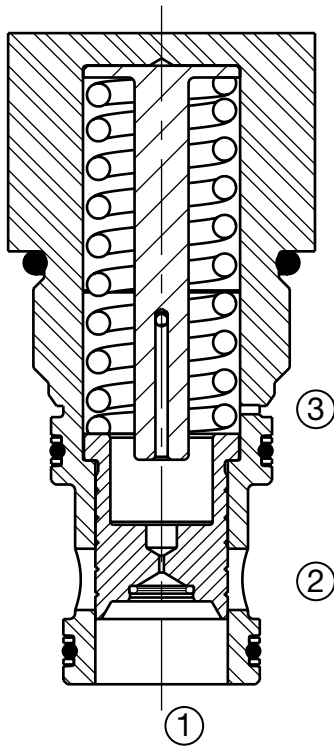
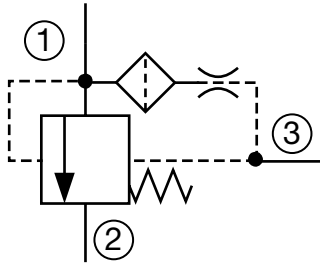

Description

A screw-in cartridge, pressure sensing valve with multifunction potential when used with flow, pressure and directional control devices. It can be used as high flow switching or metering element, main stage for pilot operated relief or sequence valve.

Operation

Pilot flow through the spool orifice, from port 1 to port 3 creates a pressure drop and allows flow from port 1 to port 2 when the pressure drop exceeds the spring bias pressure. The valve can be remotely controlled at port 3 such as relief or solenoid valve.

Features

- Operating pressure up to 5000 psi (350 bar)
- Various bias spring settings up to 300 psi (20.7 bar)
- Quiet, modulated response
- All external surfaces zinc-plated
- Hardened spool and sleeve to ensure minimal wear and extend service life
- Industry common cavity

Specifications

Operating Pressure	5000 psi (350 bar)
Nominal Flow	75 gpm (284 l/min) at 100 psi (7 bar) ΔP
Fluid Operating Temp. Range	-20° to 248°F (-29° to 120°C)
Fluid Compatibility	Mineral-Based or Synthetics with lubricating properties
Viscosity	50 to 2000 SUS (7.4 to 420 cSt)
Filtration	21/19/16 or cleaner per (ISO 4406)
Installation	No orientation restrictions
Cavity	FC16-S3 (see <i>Line Bodies & Cavities</i> section)
Cavity Tools	Rougher: 02581797 Finisher: 02581798
Cartridge Weight	1.0 lb (0.454 kg)
Cartridge Material	Steel with hardened work surfaces. Zinc plated exposed surfaces. Buna N or Viton® o-rings. Solid thermoplastic polyester back-up rings.
Seal Kits	Buna-N P/N: 02610198 Viton® P/N: 02610199
Vent Flow Rate	Approximately 0.15 gpm (0.57 lpm)

Performance

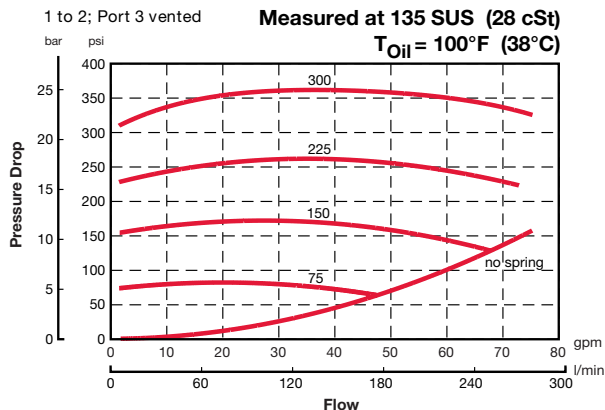

Application

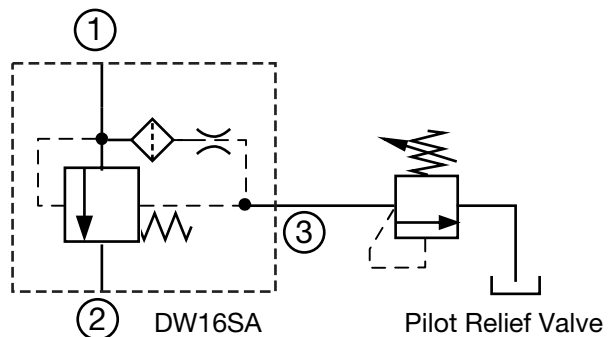

Pressure Relief / Sequence Application

PRESSURE SENSING VALVES

Dimensions

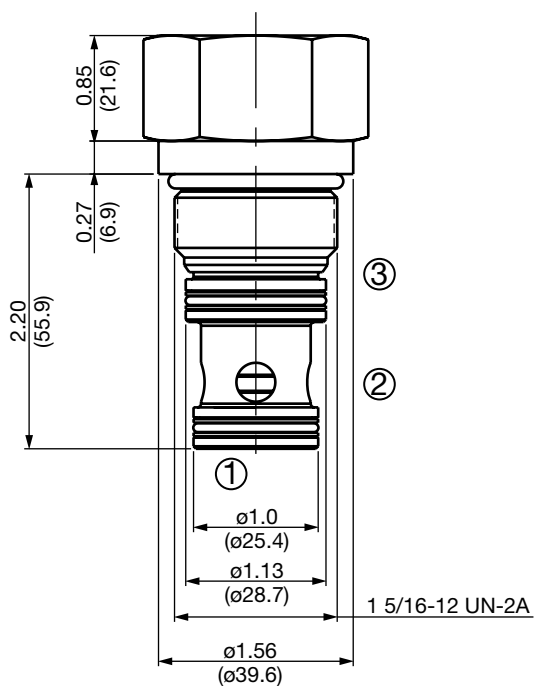
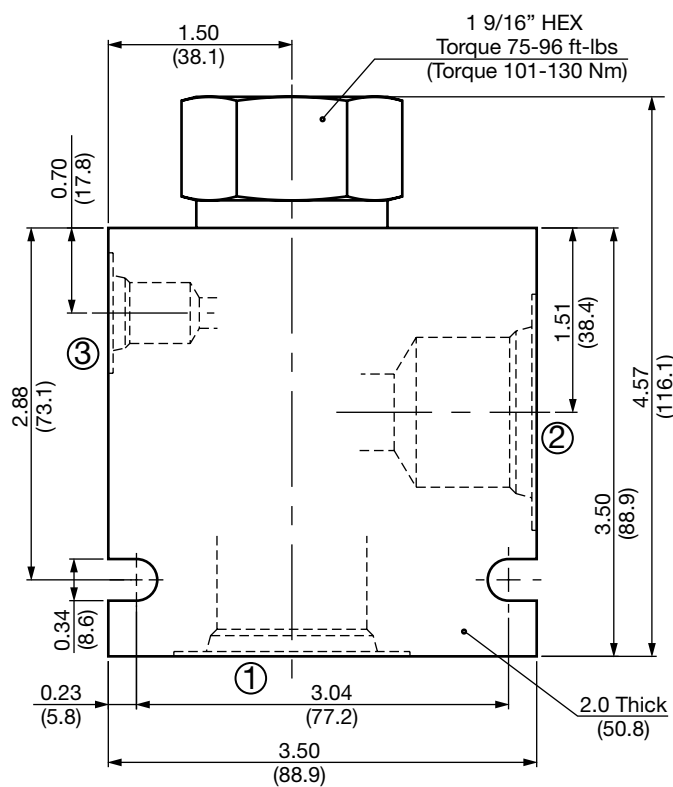

Model Code

DW16SA-01-AS16-N-300

Valve Model

Body & Ports

- C = Cartridge only
 - AS16 = SAE-16 Ports, aluminum Body
 - SS16 = SAE-16 Ports, steel Body
- (Pilot Port = SAE-6)

Seals

- N = Buna-N
- V = Viton®

Bias Spring

- 75 = 75 psi
- 150 = 150 psi
- 225 = 225 psi
- 300 = 300 psi

All measurements in inches (mm).
Subject to technical modifications

PN#02087369 / 10.19 / CHD1110-1389

Standard Line Bodies*

Code	Part No	Material	Pressure Rating	Weight
FH16S3-AS16	02582078	Aluminum, anodized	3500 psi (245 bar)	2.34 lbs (1.06 kg)
FH16S3-SS16	02582079	Steel, zinc plated	6000 psi (420 bar)	6.80 lbs (3.09 kg)

*Please refer to Line Bodies & Cavities section for details

PRESSURE SENSING VALVES

DW10SC-01

Normally Open, Vented, Spool Type

Up to 15 gpm (57 lpm) • 5000 psi (350 bar)

Hydraulic Symbol

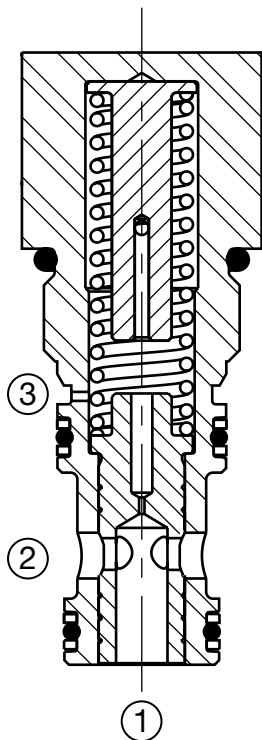
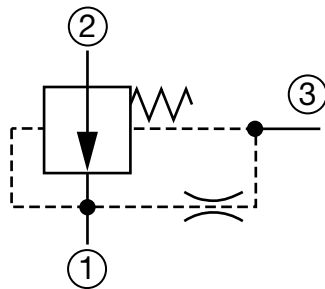

Description

A screw-in cartridge, spring biased, pressure sensing valve.

Operation

Pilot flow through the spool orifice, from port 1 to port 3, creates a pressure drop and tends to close the spool from port 2 to port 1 when the pressure drop exceeds the spring bias pressure.

The valve can be remotely controlled at port 3 such as a relief or solenoid valve.

Features

- Operating pressure up to 5000 psi (350 bar)
- Various bias spring settings up to 300 psi (20.7 bar)
- Quiet, modulated response
- All external surfaces zinc-plated
- Hardened spool and sleeve to ensure minimal wear and extend service life
- Industry common cavity

Specifications

Operating Pressure	5000 psi (350 bar)
Nominal Flow	8 gpm (30 l/min) at 100 psi (7 bar) ΔP
Fluid Operating Temp. Range	-20° to 248°F (-29° to 120°C)
Fluid Compatibility	Mineral-Based or Synthetics with lubricating properties
Viscosity	50 to 2000 SUS (7.4 to 420 cSt)
Filtration	21/19/16 or cleaner per (ISO 4406)
Installation	No orientation restrictions
Cavity	FC10-S3 (see <i>Line Bodies & Cavities</i> section)
Cavity Tools	Rougher: 02581794 Finisher: 02581795
Cartridge Weight	0.35 lb (0.158 kg)
Cartridge Material	Steel with hardened work surfaces. Zinc plated exposed surfaces. Buna N or Viton® o-rings. Solid thermoplastic polyester back-up rings.
Seal Kits	Buna-N P/N: 02610278 Viton® P/N: 02610279
Vent Flow Rate	Approximately 0.15 gpm (0.57 lpm)

Performance

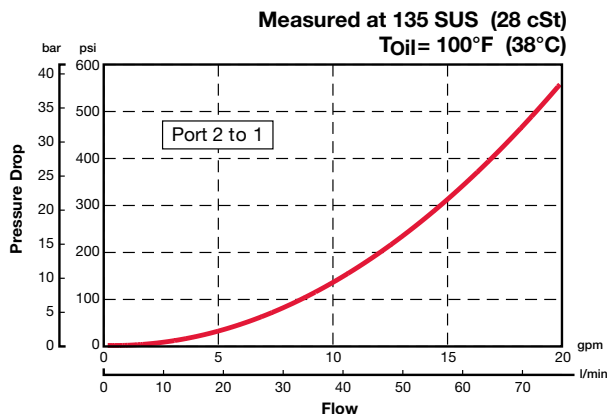

Application

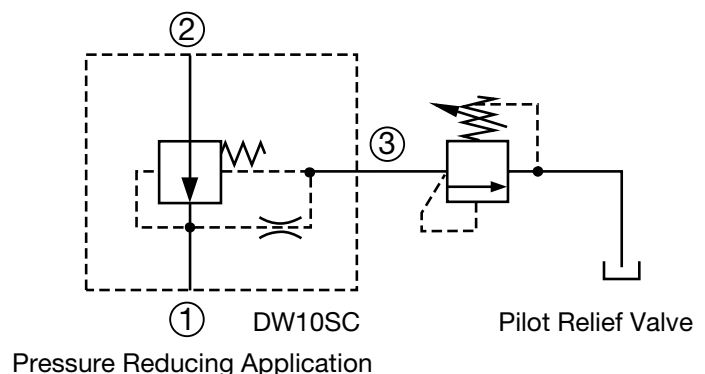

PRESSURE SENSING VALVES

Dimensions

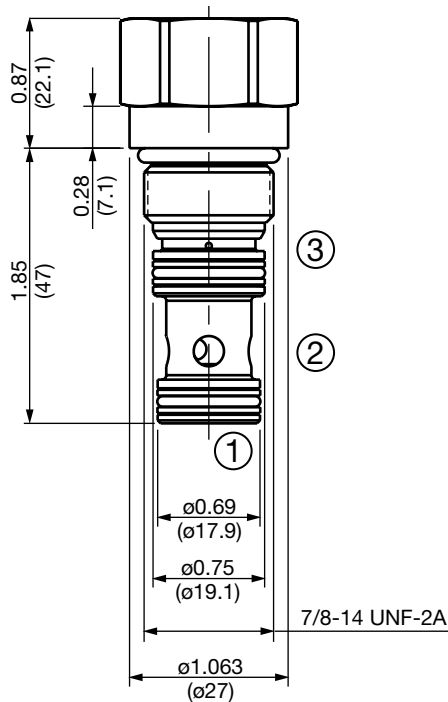
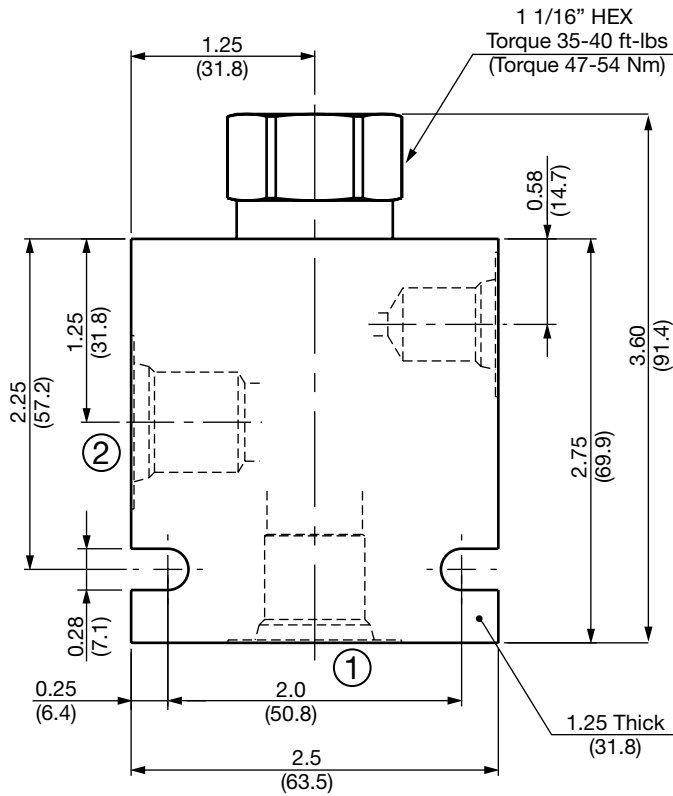

Model Code

DW10SC-01-AS8-N-300

Valve Model

Body & Ports

- C = Cartridge only
 - AS8 = SAE-8 Ports, aluminum Body
 - SS8 = SAE-8 Ports, steel Body
- (Pilot Port = SAE-6)

Seals

- N = Buna-N
- V = Viton®

Bias Spring

- 100 = 100 psi
- 200 = 200 psi
- 300 = 300 psi

Compensation

2 to 1: orifice downstream Measured at 135 SUS (28 cSt)
T_{Oil} = 100°F (38°C)

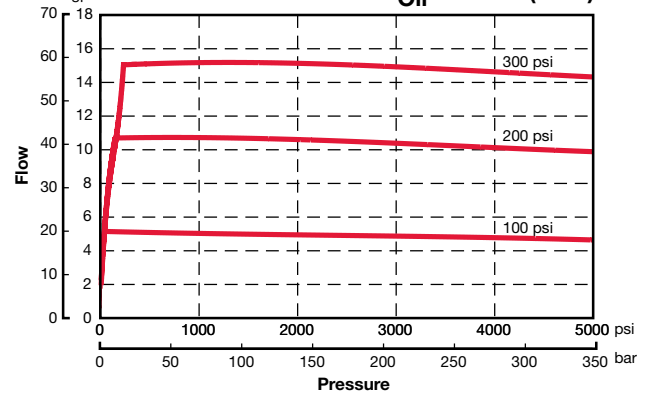

Standard Line Bodies*

Code	Part No	Material	Pressure Rating	Weight
FH10S3-AS8	02582076	Aluminum, anodized	3500 psi (245 bar)	0.59 lbs (0.27 kg)
FH10S3-SS8	02582077	Steel, zinc plated	6000 psi (420 bar)	1.67 lbs (0.76 kg)

*Please refer to Line Bodies & Cavities section for details

All measurements in inches (mm).
Subject to technical modifications

PRESSURE SENSING VALVES

DW16SC-01

Normally Open, Vented, Spool Type

Up to 30 gpm (114 lpm) • 5000 psi (350 bar)

Hydraulic Symbol

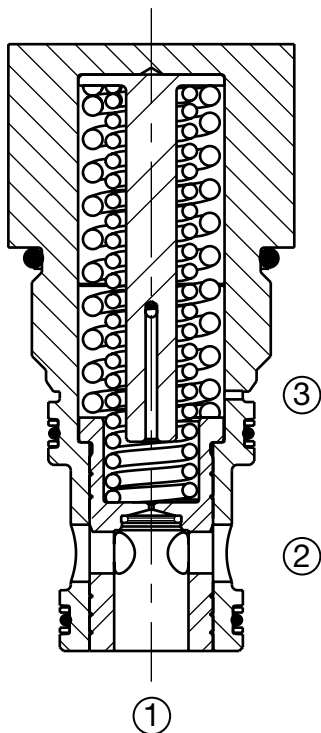
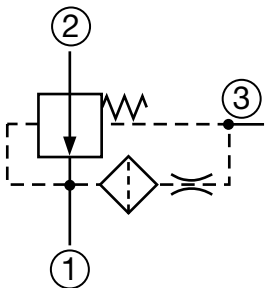

Description

A screw-in cartridge, spring biased, pressure sensing valve.

Operation

Pilot flow through the spool orifice, from port 1 to port 3, creates a pressure drop and tends to close the spool from port 2 to port 1 when the pressure drop exceeds the spring bias pressure.

The valve can be remotely controlled at port 3 such as a relief or solenoid valve.

Features

- Operating pressure up to 5000 psi (350 bar)
- Various bias spring settings up to 300 psi (20.7 bar)
- Quiet, modulated response
- All external surfaces zinc-plated
- Hardened spool and sleeve to ensure minimal wear and extend service life
- Industry common cavity

Specifications

Operating Pressure	5000 psi (350 bar)
Nominal Flow	19 gpm (72 l/min) at 100 psi (7 bar) ΔP
Fluid Operating Temp. Range	-20° to 248°F (-29° to 120°C)
Fluid Compatibility	Mineral-Based or Synthetics with lubricating properties
Viscosity	50 to 2000 SUS (7.4 to 420 cSt)
Filtration	21/19/16 or cleaner per (ISO 4406)
Installation	No orientation restrictions
Cavity	FC16-S3 (see <i>Line Bodies & Cavities</i> section)
Cavity Tools	Rougher: 02581797 Finisher: 02581798
Cartridge Weight	1.0 lb (0.454 kg)
Cartridge Material	Steel with hardened work surfaces. Zinc plated exposed surfaces. Buna N or Viton® o-rings. Solid thermoplastic polyester back-up rings.
Seal Kits	Buna-N P/N: 02610198 Viton® P/N: 02610199
Vent Flow Rate	Approximately 0.15 gpm (0.57 lpm)

Performance

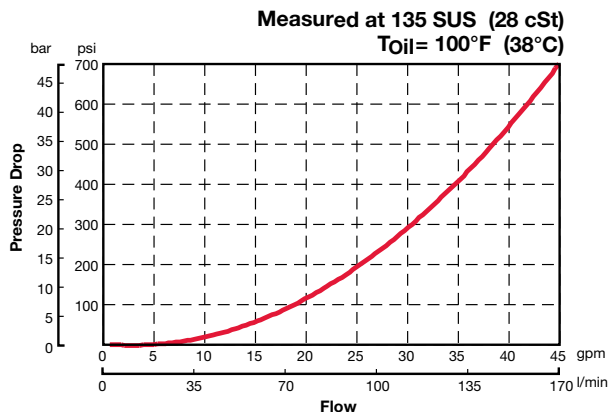

Application

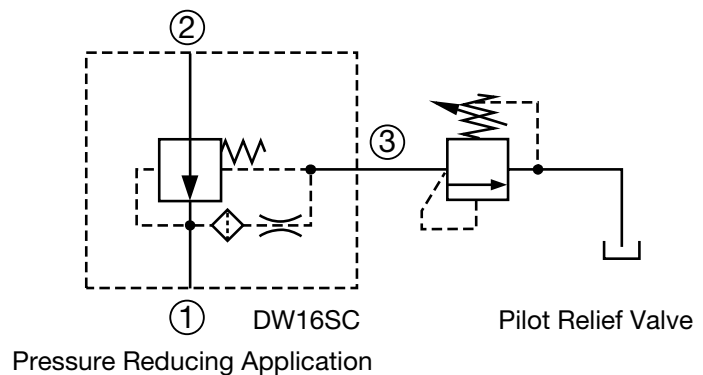

PRESSURE SENSING VALVES

Dimensions

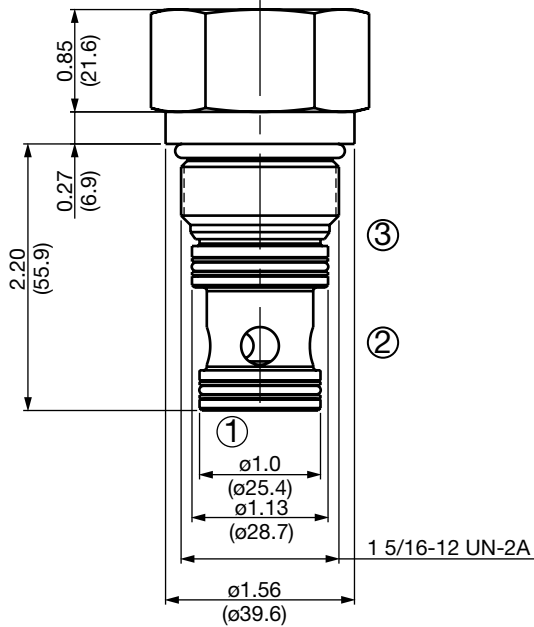
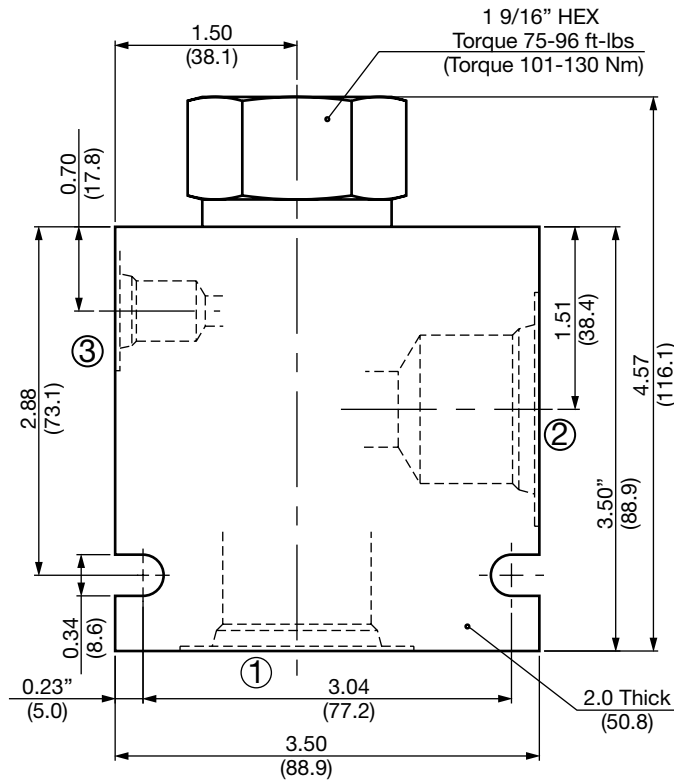

Model Code

DW16SC-01-AS16-N-300

Valve Model

Body & Ports

- C = Cartridge only
 - AS16 = SAE-16 Ports, aluminum Body
 - SS16 = SAE-16 Ports, steel Body
- (Pilot Port = SAE-6)

Seals

- N = Buna-N
- V = Viton®

Bias Spring

- 100 = 100 psi
- 150 = 150 psi
- 200 = 200 psi
- 300 = 300 psi

All measurements in inches (mm).
Subject to technical modifications

PN#02087369 / 10.19 / CHD1110-1389

Standard Line Bodies*

Code	Part No	Material	Pressure Rating	Weight
FH16S3-AS16	02582078	Aluminum, anodized	3500 psi (245 bar)	2.34 lbs (1.06 kg)
FH16S3-SS16	02582079	Steel, zinc plated	6000 psi (420 bar)	6.80 lbs (3.09 kg)

*Please refer to Line Bodies & Cavities section for details

PRESSURE SENSING VALVES

DW10V-01

Normally Open, Spool Type

Up to 15 gpm (57 lpm) • 5000 psi (350 bar)

Hydraulic Symbol

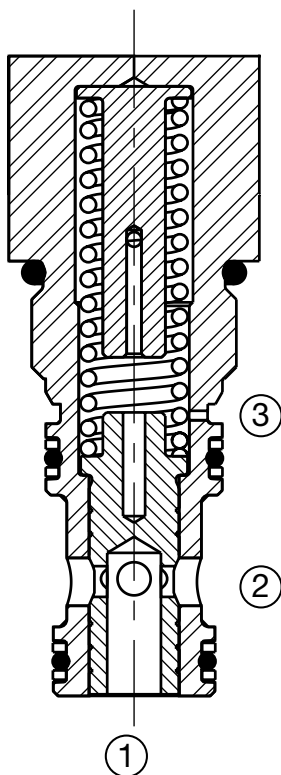
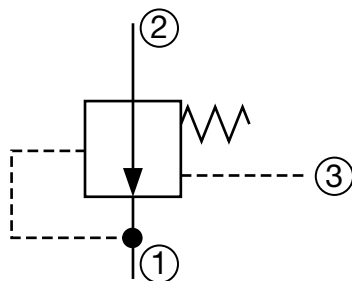

Description

A screw-in cartridge, pressure sensing valve intended for use upstream of a fixed or variable orifice to provide a constant flow rate regardless of load pressure changes.

Operation

The spool begins to shift when the pressure at port 1 exceeds the combined pressure at port 3 plus the bias spring pressure. It is possible to create a pressure compensated flow control package by connecting port 1 upstream and port 3 downstream of a control orifice.

Features

- Operating pressure up to 5000 psi (350 bar)
- Various bias spring settings up to 300 psi (20.7 bar)
- Quiet, modulated response
- All external surfaces zinc-plated
- Hardened spool and sleeve to ensure minimal wear and extend service life
- Industry common cavity

Specifications

Operating Pressure	5000 psi (350 bar)
Nominal Flow	8 gpm (30 l/min) at 100 psi (7 bar) ΔP
Fluid Operating Temp. Range	-20° to 248°F (-29° to 120°C)
Fluid Compatibility	Mineral-Based or Synthetics with lubricating properties
Viscosity	50 to 2000 SUS (7.4 to 420 cSt)
Filtration	21/19/16 or cleaner per (ISO 4406)
Installation	No orientation restrictions
Cavity	FC10-S3 (see <i>Line Bodies & Cavities</i> section)
Cavity Tools	Rougher: 02581794 Finisher: 02581795
Cartridge Weight	0.35 lb (0.158 kg)
Cartridge Material	Steel with hardened work surfaces. Zinc plated exposed surfaces. Buna N or Viton® o-rings. Solid thermoplastic polyester back-up rings.
Seal Kits	Buna-N FS10S3-N P/N: 02610278 Viton® FS10S3-V P/N: 02610279

Performance

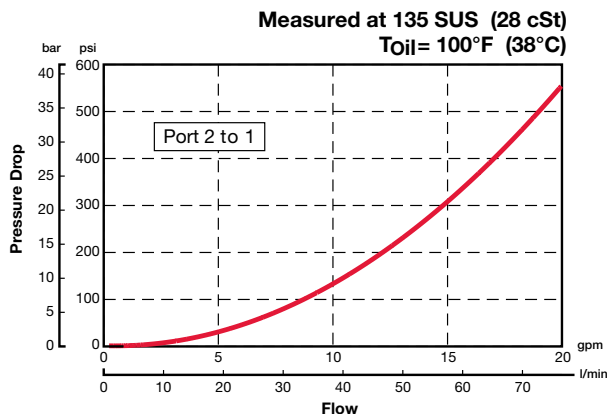

Application

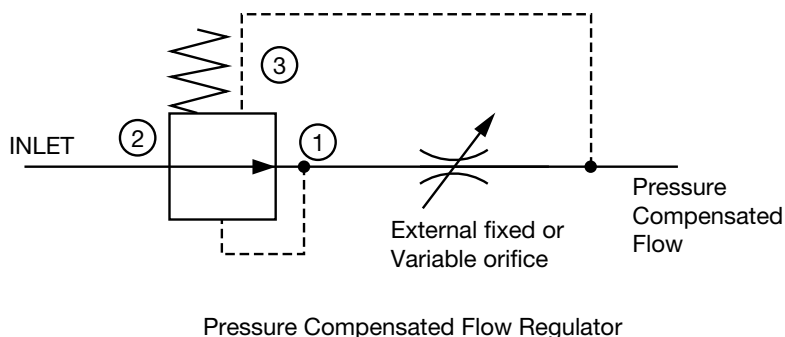

PRESSURE SENSING VALVES

Dimensions

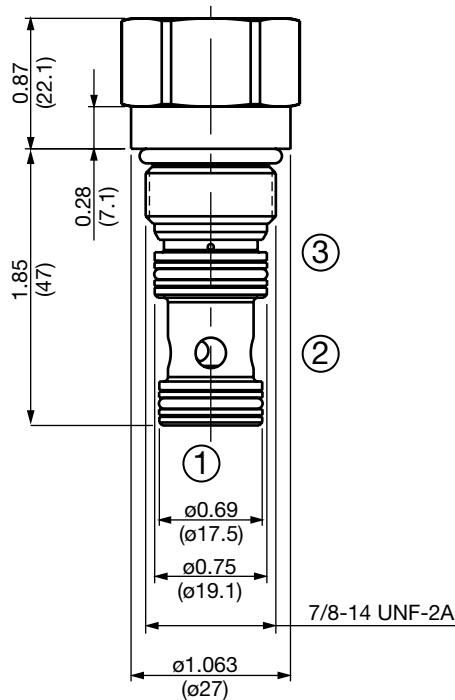
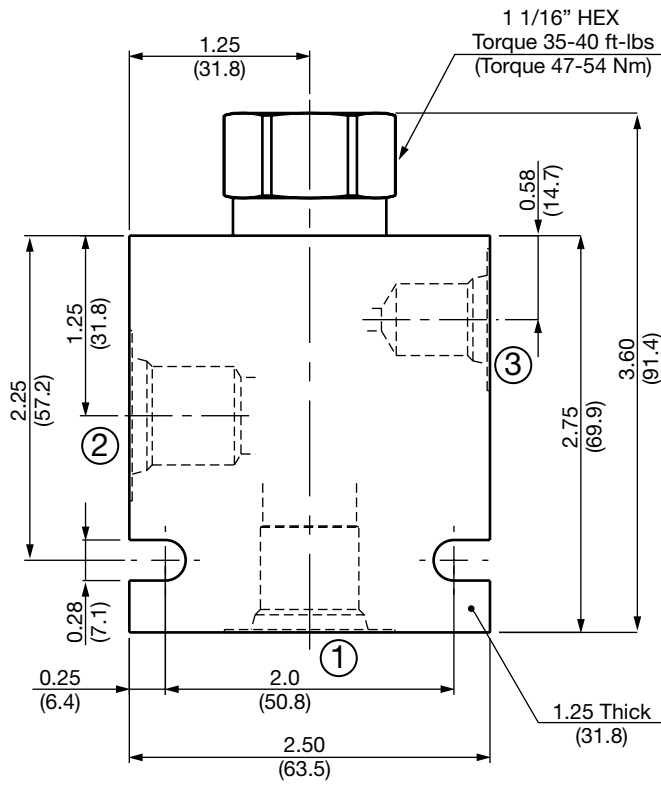

Model Code

DW10V-01-AS8-N-300

Valve Model

Body & Ports

- C = Cartridge only
 - AS8 = SAE-8 Ports, aluminum Body
 - SS8 = SAE-8 Ports, steel Body
- (Pilot Port = SAE-6)

Seals

- N = Buna-N
- V = Viton®

Bias Spring

- 100 = 100 psi
- 200 = 200 psi
- 300 = 300 psi

Compensation

2 to 1: orifice downstream

Measured at 135 SUS (28 cSt)

T_{Oil} = 100°F (38°C)

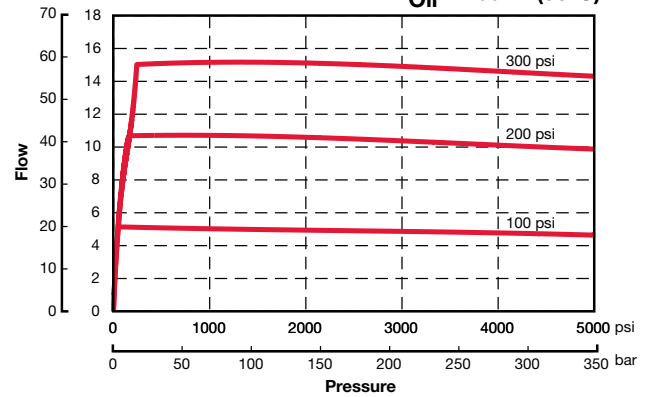

All measurements in inches (mm).
Subject to technical modifications

PN#02087369 / 10.19 / CHD1110-1389

Standard Line Bodies*

Code	Part No	Material	Pressure Rating	Weight
FH10S3-AS8	02582076	Aluminum, anodized	3500 psi (245 bar)	0.59 lbs (0.27 kg)
FH10S3-SS8	02582077	Steel, zinc plated	6000 psi (420 bar)	1.67 lbs (0.76 kg)

*Please refer to Line Bodies & Cavities section for details

HYDAC

E11

PRESSURE SENSING VALVES

DW16V-01

Normally Open, Spool Type

Up to 30 gpm (114 lpm) • 5000 psi (350 bar)

Hydraulic Symbol

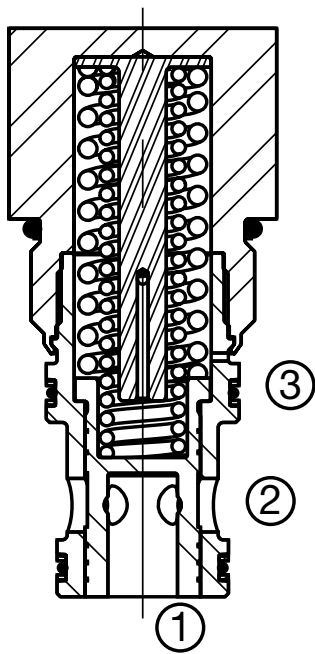
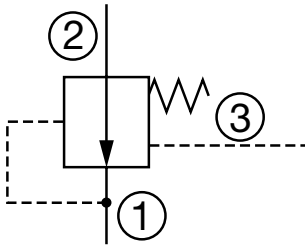

Description

A screw-in cartridge, pressure sensing valve intended for use upstream of a fixed or variable orifice to provide a constant flow rate regardless of load pressure changes.

Operation

The spool begins to shift when the pressure at port 1 exceeds the combined pressure at port 3 plus the bias spring pressure. It is possible to create a pressure compensated flow control package by connecting port 1 upstream and port 3 downstream of a control orifice.

Features

- Operating pressure up to 5000 psi (350 bar)
- Various bias spring settings up to 300 psi (20.7 bar)
- Quiet, modulated response
- All external surfaces zinc-plated
- Hardened spool and sleeve to ensure minimal wear and extend service life
- Industry common cavity

Specifications

Operating Pressure	5000 psi (350 bar)
Nominal Flow	19 gpm (72 l/min) at 100 psi (7 bar) ΔP
Fluid Operating Temp. Range	-20° to 248°F (-29° to 120°C)
Fluid Compatibility	Mineral-Based or Synthetics with lubricating properties
Viscosity	50 to 2000 SUS (7.4 to 420 cSt)
Filtration	21/19/16 or cleaner per (ISO 4406)
Installation	No orientation restrictions
Cavity	FC16-S3 (see <i>Line Bodies & Cavities</i> section)
Cavity Tools	Rougher: 02581797 Finisher: 02581798
Cartridge Weight	1.0 lb (0.454 kg)
Cartridge Material	Steel with hardened work surfaces. Zinc plated exposed surfaces. Buna N or Viton® o-rings Solid thermoplastic polyester back-up rings
Seal Kits	Buna-N FS16S3-N P/N: 02610198 Viton® FS16S3-V P/N: 02610199

Performance

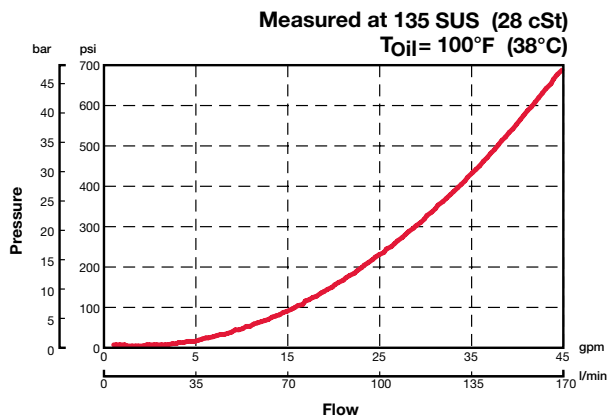

Application

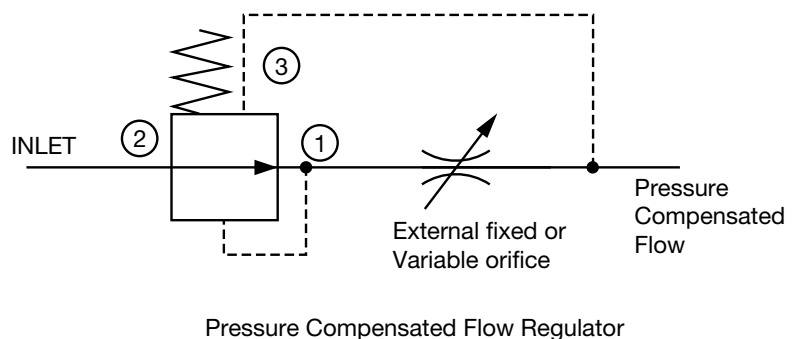

PRESSURE SENSING VALVES

Dimensions

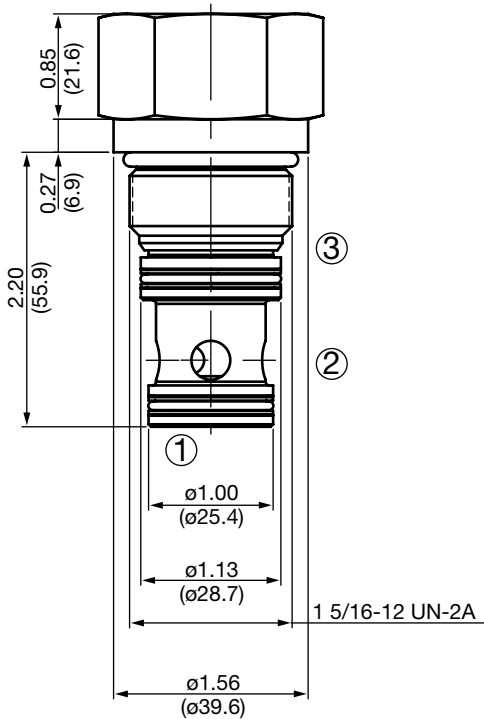
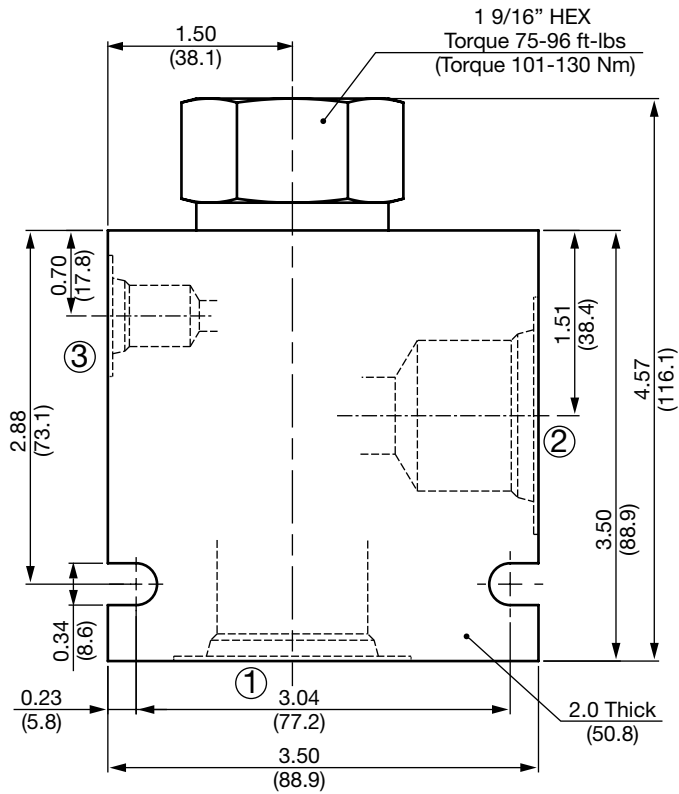

Model Code

DW16V-01-AS16-N-300

Valve Model

Body & Ports

- C = Cartridge only
 - AS16 = SAE-16 Ports, aluminum Body
 - SS16 = SAE-16 Ports, steel Body
- (Pilot Port = SAE-6)

Seals

- N = Buna-N
- V = Viton®

Bias Spring

- 100 = 100 psi
- 150 = 150 psi
- 200 = 200 psi
- 300 = 300 psi

Compensation

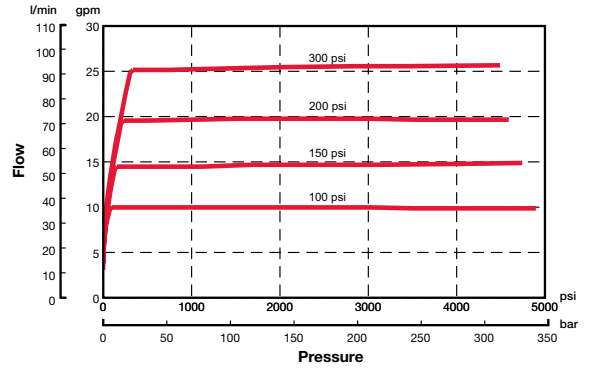

All measurements in inches (mm).
Subject to technical modifications

Standard Line Bodies*

Code	Part No	Material	Pressure Rating	Weight
FH16S3-AS16	02582078	Aluminum, anodized	3500 psi (245 bar)	2.34 lb (1.06 kg)
FH16S3-SS16	02582079	Steel, zinc plated	6000 psi (420 bar)	6.80 lbs (3.09 kg)

*Please refer to Line Bodies & Cavities section for details

PRESSURE SENSING VALVES

DW10Z-01

Normally Closed, Spool Type

Up to 40 gpm (151 lpm) • 5000 psi (350 bar)

Hydraulic Symbol

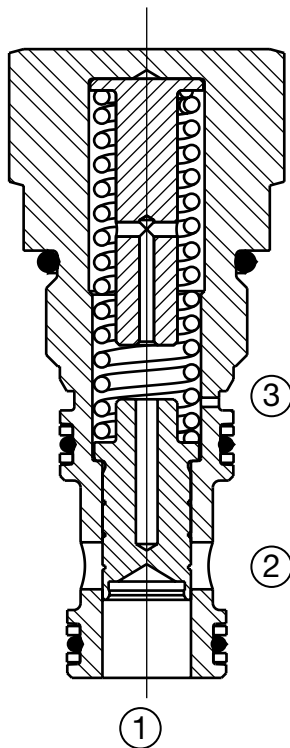
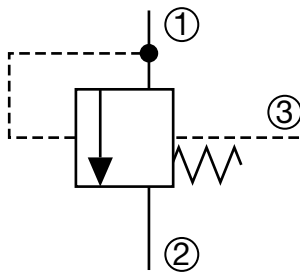

Description

A screw-in cartridge, pressure sensing valve with multifunction potential when used with flow, pressure and directional control devices.

Operation

The spool begins to shift allowing flow from port 1 to port 2 only when pressure at port 1 exceeds the combined pressure at port 3 plus the bias spring pressure setting. With no pressure at port 3, flow will be allowed from port 1 to port 2 once the bias spring force is overcome with pressure at port 1.

It is also possible to create pressure compensation by connecting port 1 upstream and port 3 downstream of a control orifice.

Features

- Operating pressure up to 5000 psi (350 bar)
- Various bias spring settings up to 300 psi (20.7 bar)
- Quiet, modulated response
- All external surfaces zinc-plated
- Hardened spool and sleeve to ensure minimal wear and extend service life
- Industry common cavity

Specifications

Operating Pressure	5000 psi (350 bar)
Nominal Flow	40 gpm (151 l/min)
Internal Leakage	5 cu in/min at 3000 psi (82cc/min at 207 bar)
Fluid Operating Temp. Range	-20° to 248°F (-29° to 120°C)
Fluid Compatibility	Mineral-Based or Synthetics with lubricating properties
Viscosity	50 to 2000 SUS (7.4 to 420 cSt)
Filtration	21/19/16 or cleaner per (ISO 4406)
Installation	No orientation restrictions
Cavity	FC10-S3 (see <i>Line Bodies & Cavities</i> section)
Cavity Tools	Rougher: 02581794 Finisher: 02581795
Cartridge Weight	0.35 lb (0.158 kg)
Cartridge Material	Steel with hardened work surfaces. Zinc plated exposed surfaces. Buna N or Viton® o-rings. Solid thermoplastic polyester back-up rings.
Seal Kits	Buna-N P/N: 02610278 Viton® P/N: 02610279

Performance

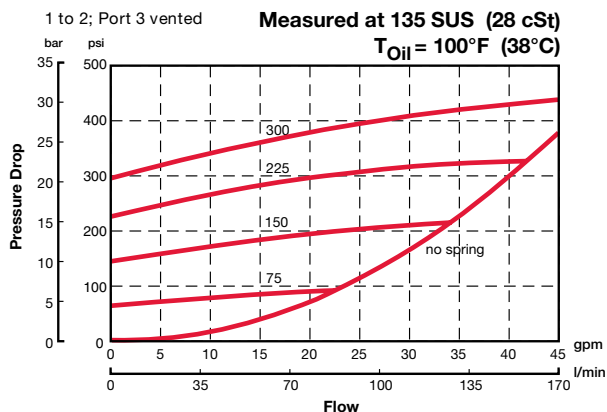

Application

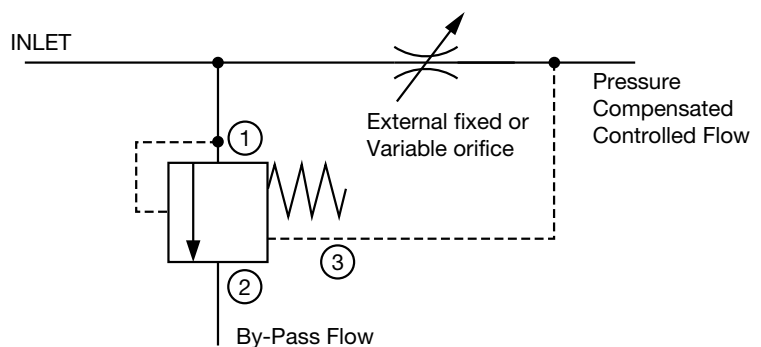

Pressure Compensated Priority Flow Regulator

PRESSURE SENSING VALVES

Dimensions

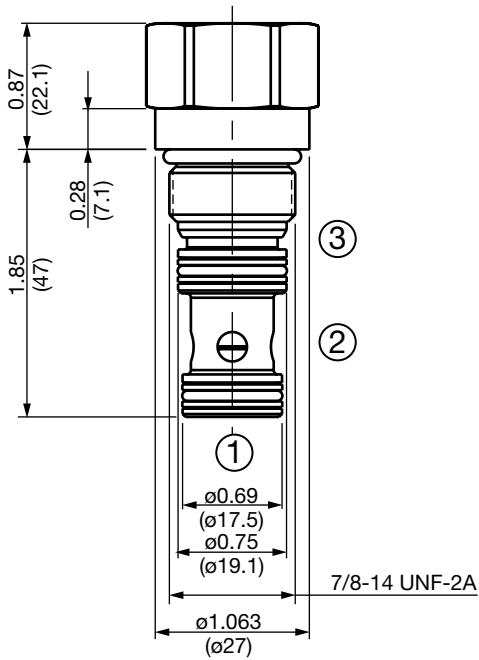
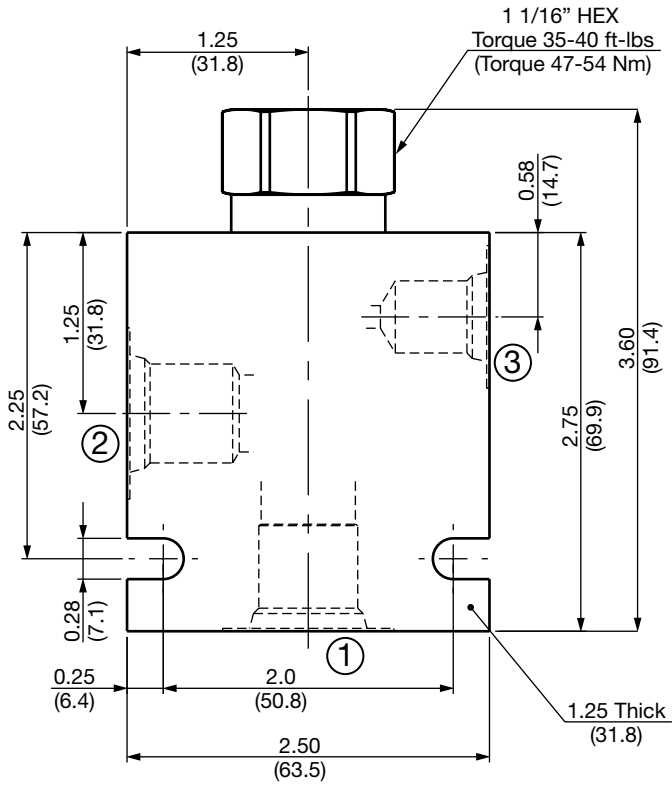

Model Code

DW10Z-01-AS8-N-300

Valve Model

Body & Ports

- C = Cartridge only
 - AS8 = SAE-8 Ports, aluminum Body
 - SS8 = SAE-8 Ports, steel Body
- (Pilot Port = SAE-6)

Seals

- N = Buna-N
- V = Viton®

Bias Spring

- 75 = 75 psi
- 150 = 150 psi
- 225 = 225 psi
- 300 = 300 psi

All measurements in inches (mm).
Subject to technical modifications

PN#02087369 / 10.19 / CHD1110-1389

Standard Line Bodies*

Code	Part No	Material	Pressure Rating	Weight
FH10S3-AS8	02582076	Aluminum, anodized	3500 psi (245 bar)	0.59 lbs (0.27 kg)
FH10S3-SS8	02582077	Steel, zinc plated	6000 psi (420 bar)	1.67 lbs (0.76 kg)

*Please refer to Line Bodies & Cavities section for details

PRESSURE SENSING VALVES

DW16Z-01

Normally Closed, Spool Type

Up to 75 gpm (284 lpm) • 5000 psi (350 bar)

Hydraulic Symbol

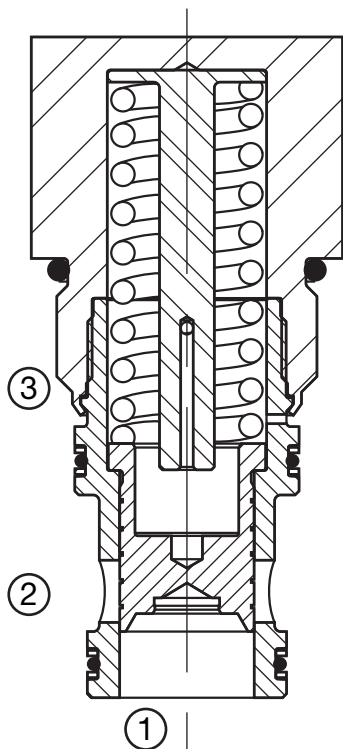
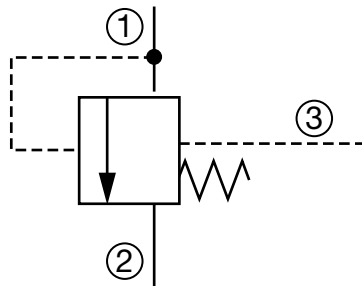

Description

A screw-in cartridge, pressure sensing valve with multifunction potential when used with flow, pressure and directional control devices.

Operation

The spool begins to shift allowing flow from port 1 to port 2 only when pressure at port 1 exceeds the combined pressure at port 3 plus the bias spring pressure setting. With no pressure at port 3, flow will be allowed from port 1 to port 2 once the bias spring force is overcome with pressure at port 1.

It is also possible to create pressure compensation by connecting port 1 upstream and port 3 downstream of a control orifice.

Features

- Operating pressure up to 5000 psi (350 bar)
- Various bias spring settings up to 300 psi (20.7 bar)
- Quiet, modulated response
- All external surfaces zinc-plated
- Hardened spool and sleeve to ensure minimal wear and extend service life
- Industry common cavity

Specifications

Operating Pressure	5000 psi (350 bar)
Nominal Flow	75 gpm (284 l/min)
Fluid Operating Temp. Range	-20° to 248°F (-29° to 120°C)
Fluid Compatibility	Mineral-Based or Synthetics with lubricating properties
Viscosity	50 to 2000 SUS (7.4 to 420 cSt)
Filtration	21/19/16 or cleaner per (ISO 4406)
Installation	No orientation restrictions
Cavity	FC16-S3 (see <i>Line Bodies & Cavities</i> section)
Cavity Tools	Rougher: 02581797 Finisher: 02581798
Cartridge Weight	1.0 lb (0.454 kg)
Cartridge Material	Steel with hardened work surfaces. Zinc plated exposed surfaces. Buna N or Viton® o-rings Solid thermoplastic polyester back-up rings
Seal Kits	Buna-N FS16S3-N P/N: 02610198 Viton® FS16S3-V P/N: 02610199

Performance

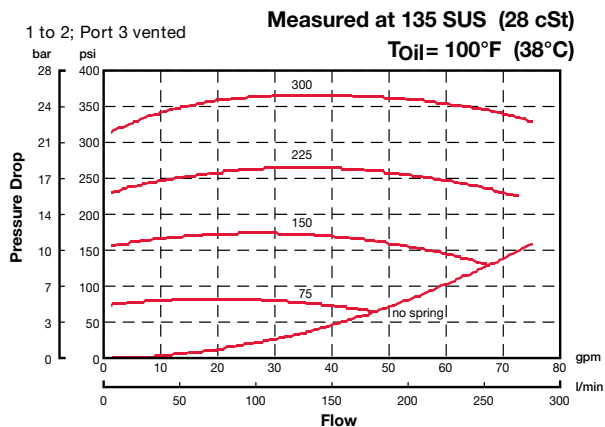

Application

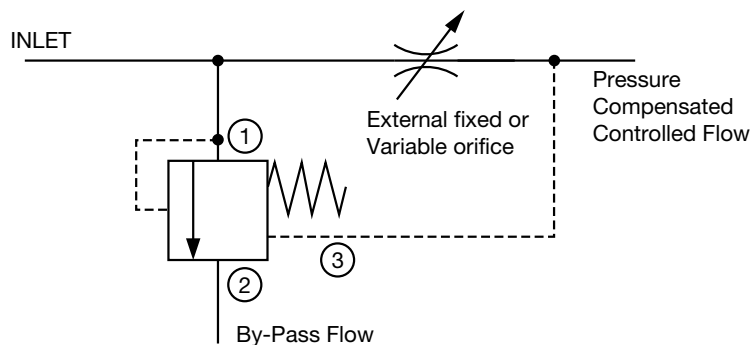

Pressure Compensated Priority Flow Regulator

PRESSURE SENSING VALVES

Dimensions

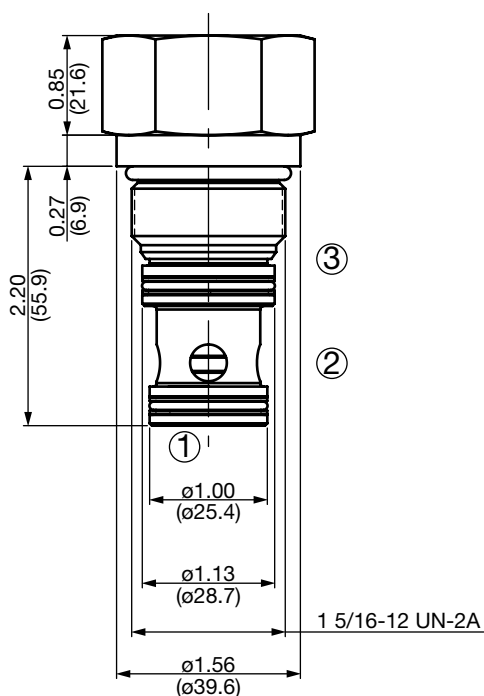
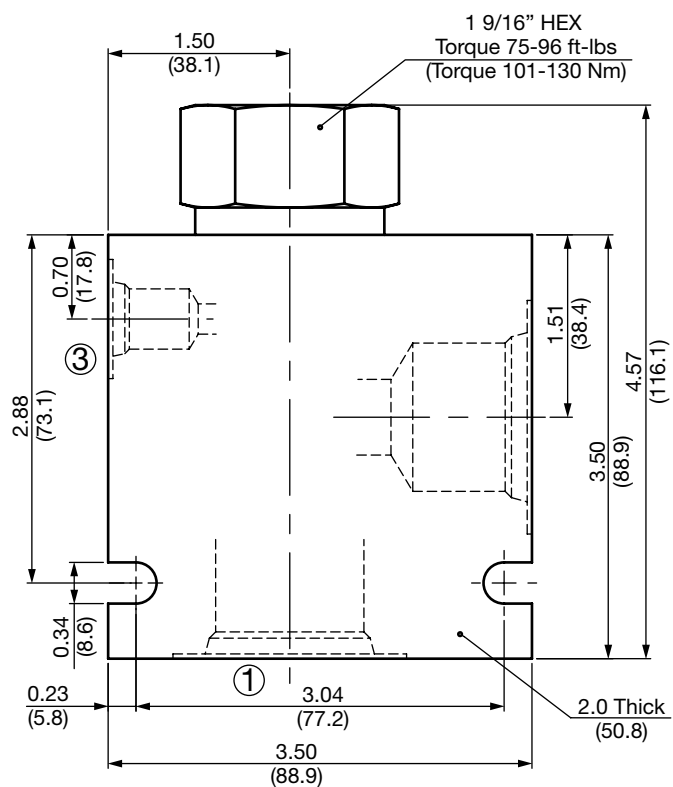

Model Code

DW16Z-01-AS16-N-300

Valve Model

Body & Ports

- C = Cartridge only
 - AS16 = SAE-16 Ports, aluminum Body
 - SS16 = SAE-16 Ports, steel Body
- (Pilot Port = SAE-6)

Seals

- N = Buna-N
- V = Viton®

Bias Spring

- 75 = 75 psi
- 150 = 150 psi
- 200 = 200 psi
- 300 = 300 psi

All measurements in inches (mm).
Subject to technical modifications

Standard Line Bodies*

Code	Part No	Material	Pressure Rating	Weight
FH16S3-AS16	02582078	Aluminum, anodized	3500 psi (245 bar)	2.34 lb (1.06 kg)
FH16S3-SS16	02582079	Steel, zinc plated	6000 psi (420 bar)	6.80 lbs (3.09 kg)

*Please refer to Line Bodies & Cavities section for details

PRESSURE SENSING VALVES

Notes

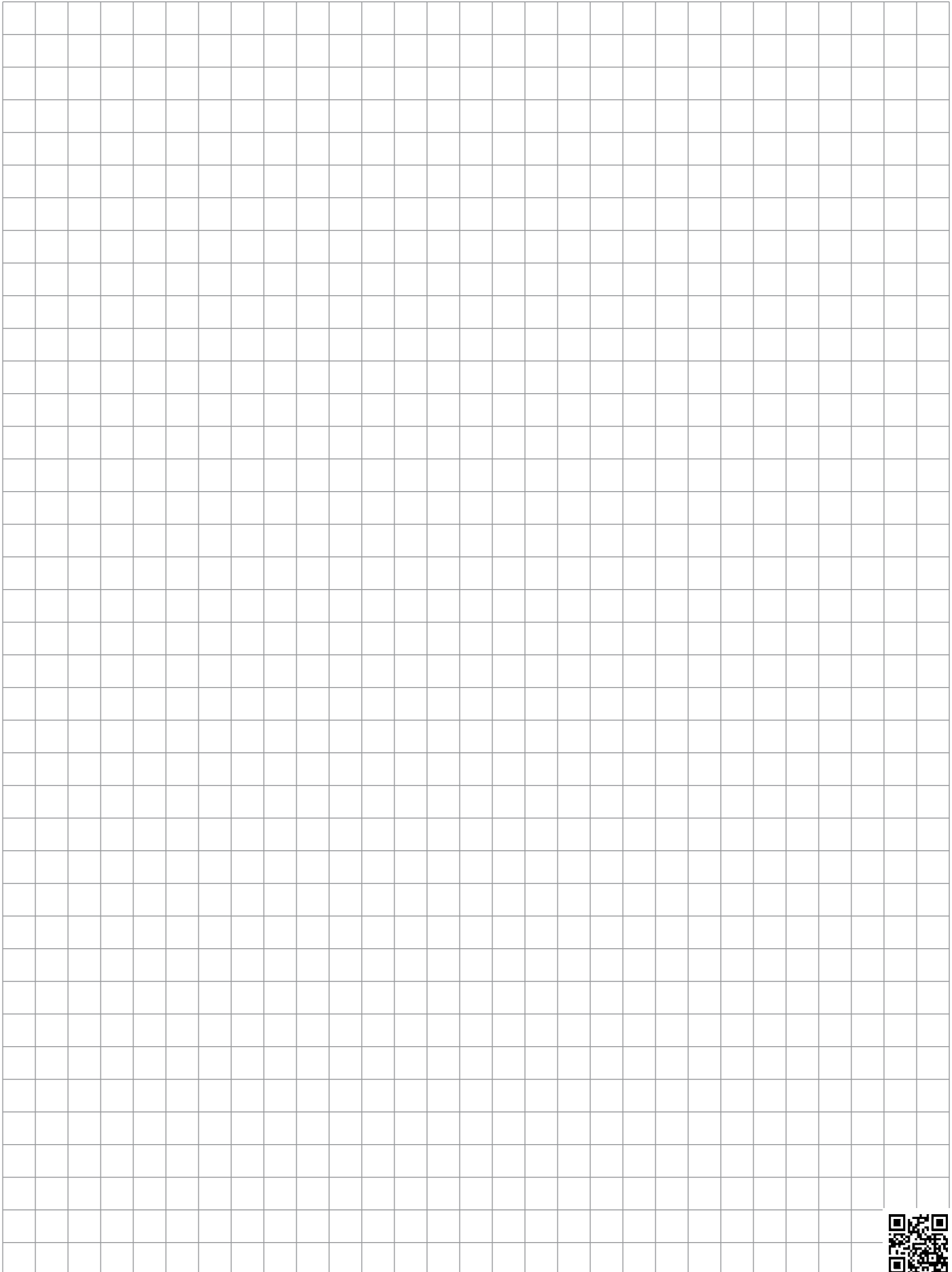
A large grid of graph paper for taking notes, consisting of 20 columns and 30 rows of small squares.

F1

Overview

Poppet Type Solenoid Valves

Poppet type valves are intended for use as load holding and blocking devices in hydraulic circuits requiring very low internal leakage. HYDAC offers a variety of Poppet type two-way and three-way normally closed or normally open unidirectional or bi-directional load holding and blocking valves. Models are available for flows up to 40 gpm (150 l/min) with pressure ratings up to 5000 psi (350 bar).

All HYDAC poppet valves are tested on an automated test stand measuring internal leakage by monitoring pressure decay, not counting drops per minute. HYDAC Poppet valves therefore provide reliable load holding and assure minimum pressure decay at the actuator.

Spool Type Solenoid Valves

HYDAC Spool Valves are offered with a wide choice of flow paths and position options to satisfy the most demanding system requirements. Models are available for flows up to 9 gpm (35 l/min) with pressure ratings up to 5000 psi (350 bar). These options include:

- 2-way, 2-position normally open and normally closed spool valves
- 3-way, 2-position spool valves
- 4-way, 2-position spool valves
- 4-way, 3-position spool valves



Features

- Low pressure drop
- Wet armature construction
- Standard Water/Weather resistant coils rated up to IP69K
- Wide voltage range
- Coils are rated for continuous duty operation
- Wide variety of voltages and molded-in connectors
- Cartridges are voltage interchangeable
- Manual overrides available on all models
- One piece body minimizes the effects of eccentricity
- All exposed cartridge surfaces are resistant corrosion
- Industry common cavity-compact size

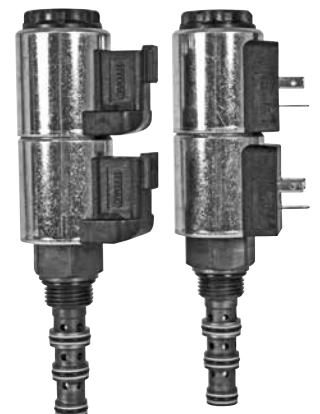

SOLENOID VALVES

WS06Y-01

Poppet Type, Normally Open, Pilot Operated

Up to 5 gpm (19 l/min) • 5000 psi (350 bar)

Hydraulic Symbol

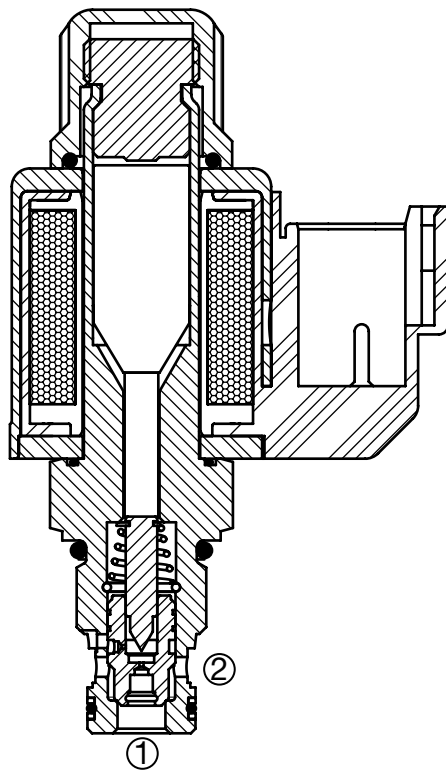
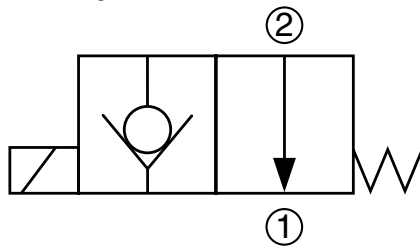

Description

A screw-in cartridge, solenoid operated, 2 way 2 position, normally open, pilot operated, poppet type intended for use as a uni-directional blocking or load holding device in hydraulic circuits requiring low internal leakage.

Operation

When de-energized the WS06Y allows flow from port 2 to port 1, while flow from port 1 to port 2 is severely restricted. When energized the valve's poppet closes on its seat, blocking flow from port 2 to port 1. Flow from port 1 to port 2 is allowed when hydraulic pressure generated overcomes solenoid force.

Specifications

Operating Pressure	5000 psi (350 bar)
Nominal Flow	3.5 gpm (13.3 l/min)
Internal Leakage	Leaktight, less than 5 drops/min. at 5000 psi (350 bar)
Fluid Operating Temp. Range	-20° to 248°F (-29° to 120°C)
Ambient Temperature Range	-20° to 140°F (-29° to 60°C)
Coil Duty Rating	Continuous from 85% to 115% of nominal voltage
Current Draw at 68°F (20°C)	984 mA at 12VDC; 492 mA at 24VDC
Minimum Pull-in Current to Operate Valve	70% of nominal amperage
Typical Response Time (Varies with Pressure and Flow)	Energized: 50ms De-Energized: 35ms
Fluid Compatibility	Mineral-Based or Synthetics with lubricating properties.
Viscosity	50 to 2000 SUS (7.4 to 420 cSt)
Filtration	21/19/16 or cleaner per (ISO 4406)
Installation	No orientation restrictions
Cavity	FC06-2 (see Line Bodies and Cavities section)
Cavity Tools	Rougher: 02582046 Finisher: 02582047
Cartridge Weight	2.7 oz (75 grams)
Coil Weight	3.1 oz (88 grams)
Cartridge Material	Steel with hardened work surfaces. Zinc plated exposed surfaces. Buna N or Viton® o-rings. Solid thermoplastic polyester back-up rings.
Coil Material	Class N, 200°C high temperature magnet wire, steel shell, polyester encapsulation.
Seal Kits	Buna-N P/N: 02610184 Viton® P/N: 02610185

Performance

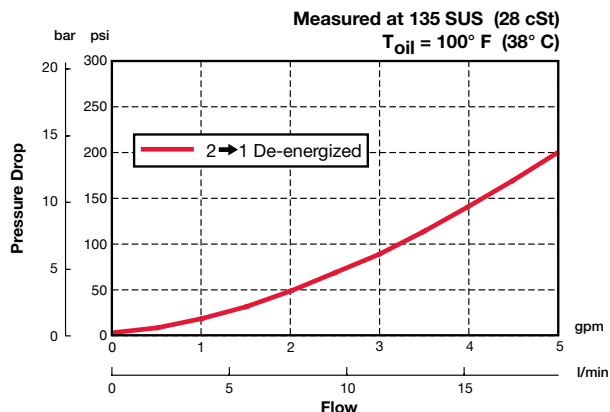

Dimensions

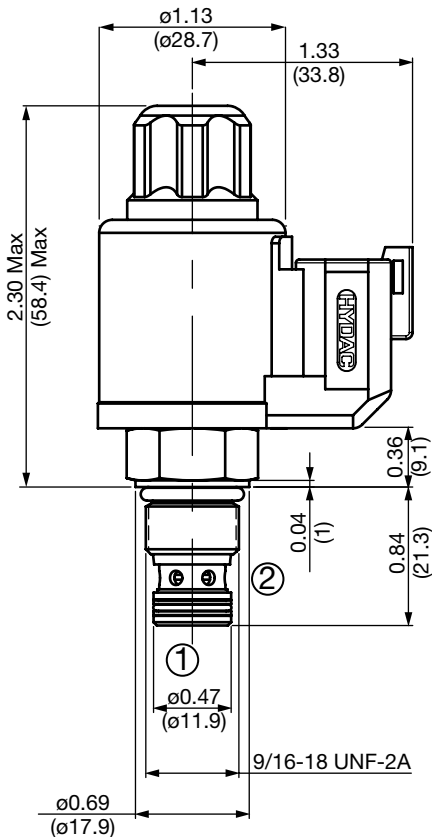
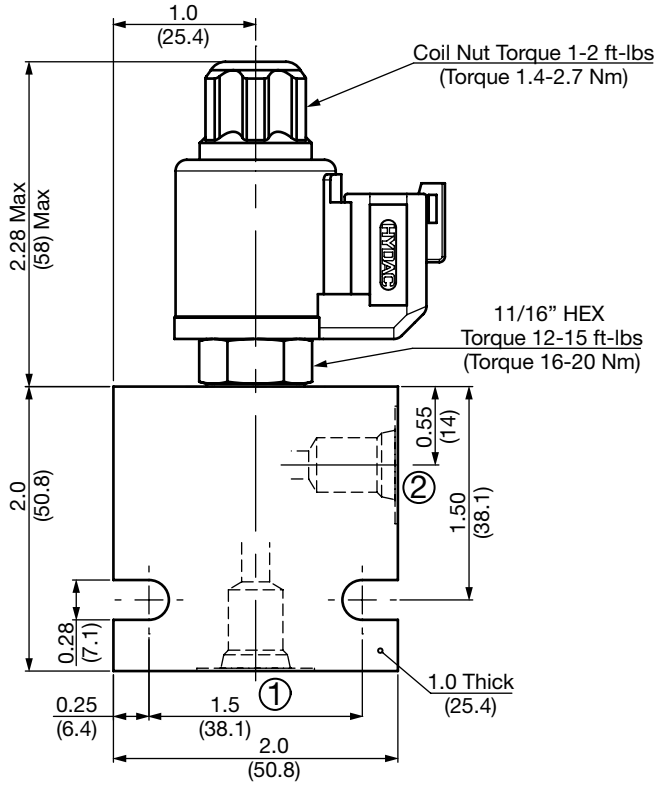

All measurements in inches (mm).
Subject to technical modifications

Model Code

WS06Y-01 M-C-N-24 DN

Valve Model

Override Option

blank = No manual override
M = Manual override, push type
(for availability consult factory)

Body & Ports

C = Cartridge only
AS4 = SAE-4 Ports, aluminum body
SS4 = SAE-4 Ports, steel body

Seals

N = Buna-N
V = Viton®

Coil Voltage

0 = No coil, cartridge only
DC 12 = 12 VDC
24 = 24 VDC
AC 115 = 105 VDC (only available with connector DG)
230 = 205 VDC (only available with connector DG)

(All model 32-1329 coils are DC. AC models require an external diode bridge mounted outside the coil)**

Coil Connector

DG = EN 175301-803-B (IP65 Rated)**
DC DL = Leadwires (2) - 18" long (46 cm) AWG18, TYPE UL 1815 (IP69K Rated)*
DN = Deutsch DT04-2P integral molded (IP69K Rated)*

Use mating plug EN 175301-803-B without diode bridge for DC voltages P/N 02600570

Use mating plug EN 175301-803-B w/diode bridge for AC voltages P/N 02600582

Coil Model 32-1329

For other coil connector types consult factory

** Mating Plugs sold separately

*Coils with internal transient suppression diode are available, consult factory.

Standard Line Bodies*

Code	Part No	Material	Pressure Rating	Weight
FH062-AS4	02600491	Aluminum, anodized	3500 psi (245 bar)	0.33 lbs (0.15 kg)
FH062-SS4	02600490	Steel, Zinc plated	6000 psi (420 bar)	0.97 lbs (0.45 kg)

*Please refer to Line Bodies & Cavities section for details

SOLENOID VALVES

WS08Y-01

Poppet Type, Normally Open, Pilot Operated

Up to 10 gpm (38 l/min) • 5000 psi (350 bar)

Hydraulic Symbol

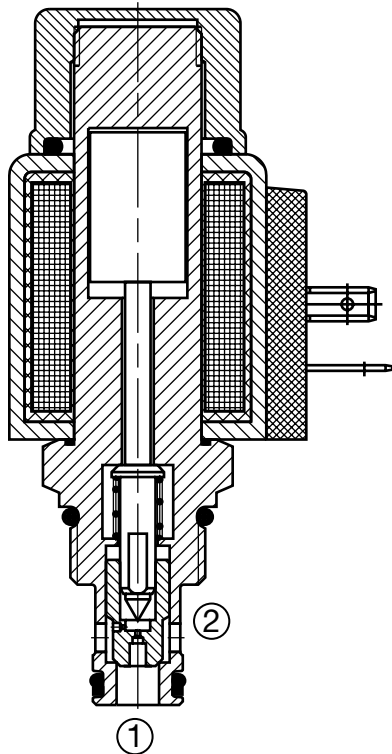
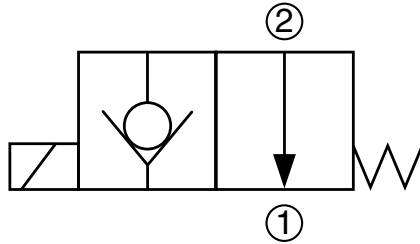

Description

A screw-in cartridge, solenoid operated, 2-way, 2 position, normally open, pilot operated, poppet type intended for use as a uni-directional blocking or load holding device in hydraulic circuits requiring low internal leakage.

Operation

When de-energized the WS08Y allows flow from port 2 to port 1, while flow from port 1 to port 2 is severely restricted. If this flow path is required see model WS08YR. When energized the valve's poppet closes on its seat, blocking flow from port 2 to port 1. Flow from port 1 to port 2 is allowed when hydraulic pressure generated force (130 to 290 psi (9 to 20 bar)) overcomes solenoid force.

Operation of Manual Override Option: To override, push and hold the override button. The override is not detented. The manual override option is intended for emergency use, not for continuous duty operation.

Features

- Push type manual override button, protected by rubber cap

Specifications

Operating Pressure	5000 psi (350 bar)
Nominal Flow	10 gpm (38 l/min)
Internal Leakage	Leaktight, less than 5 drops/min. at 5000 psi (0.25 cc/min at 350 bar)
Fluid Operating Temp. Range	-4° to 248°F (-20° to 120°C) (Consult factory for usage at temp. outside range.)
Ambient Temperature Range	-4° to 140°F (-20° to 60°C)
Coil Duty Rating	Continuous from 85% to 115% of nominal voltage
Current Draw @ 68°F (20°C)	1.5 A at 12VDC; 0.8 A at 24VDC
Min. Pull-in Voltage @ 68°F (20°C)	85% of nominal @ 5000 psi (350 bar)
Response Time (typical)	Energized: 50ms De-Energized: 35ms
Fluid Compatibility	Mineral-Based or Synthetics with lubricating properties.
Viscosity	50 to 2000 SUS (7.4 to 420 cSt)
Filtration	21/19/16 or cleaner per (ISO 4406). Use with filter rated $\beta_{10} \geq 200$.
Installation	No orientation restrictions
Cavity	FC08-2 (see Line Bodies and Cavities section)
Cavity Tools	Rougher: 02580090 Finisher: 02580091
Cartridge Weight	0.31 Lbs. (0.14 kg)
Coil Weight	0.42 Lbs. (0.19 kg)
Cartridge Material	Steel with hardened work surfaces. Zinc plated exposed surfaces. Buna N or Viton® o-rings. PTFE back-up rings.
Coil Material	Class N high temperature magnet wire, steel shell, polyamid encapsulation.
Seal Kits	Buna-N FS082-N P/N: 03033920 Viton® FS082-V P/N: 03051756

Performance

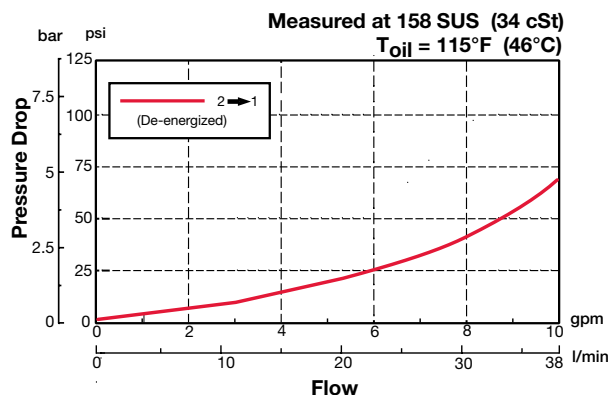

Dimensions

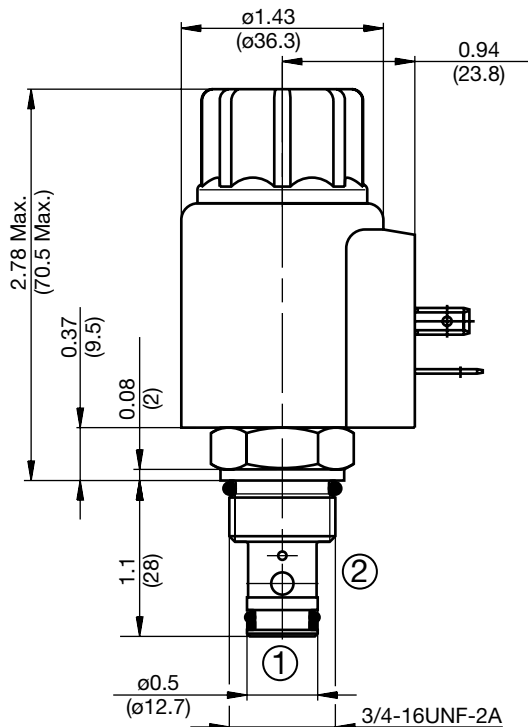
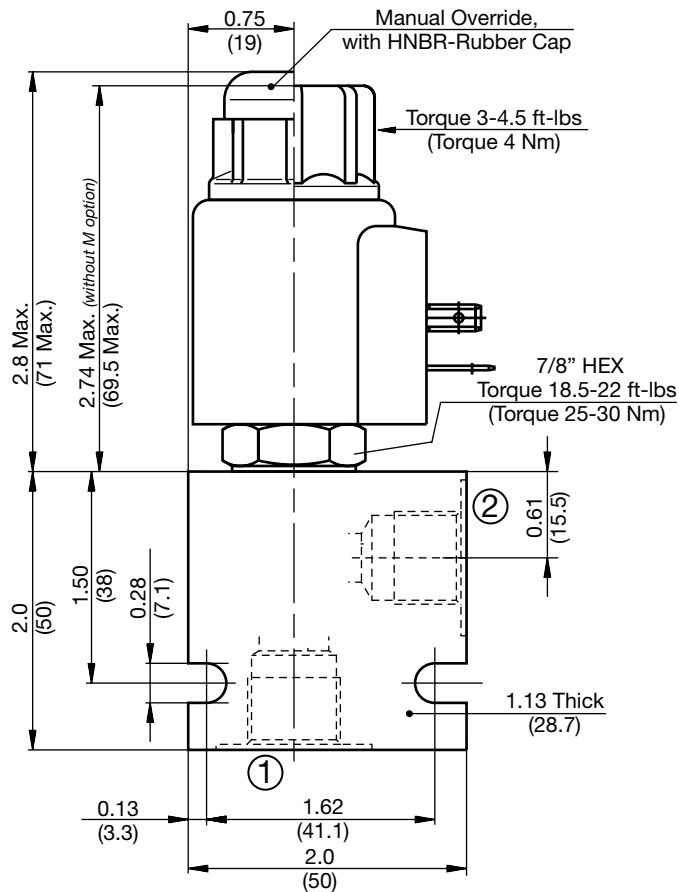

All measurements in inches (mm).
Subject to technical modifications

Model Code

WS08Y-01 M-C-N-24 DS

- Valve Model** _____
- Override Option** _____
blank = No manual override
M = Manual override, push type
- Body & Ports** _____
C = Cartridge only
AS6 = SAE-6 Ports, aluminum body
SS6 = SAE-6 Ports, steel body
- Seals** _____
N = Buna-N
V = Viton®
- Coil Voltage** _____
0 = No coil, cartridge only
- DC** _____
12 = 12 VDC
24 = 24 VDC
36 = 36 VDC
110 = 110 VDC (only available with connector DG)
- AC** _____
24 = 24 VAC
115 = 115 VAC (AC coils internally full wave rectified)
230 = 230 VAC
- Coil Connector** _____
DC DG = EN 175301-803-A
DS = Dual spade (SAEJ858a)*
DL = Leadwires (2) - 18" long (46 cm)*
DW = WeatherPak™ on leadwires - 9.5" long (24 cm)*
DN = Deutsch™ DT04-2P, molded, axial (IP69K Rated)*
DT = Amp Junior Timer™, molded, radial mount*
- AC AG = EN 175301-803-A

Coil Model 40-1836

For other coil connector types consult factory

*Coils with internal diode are available, consult factory.

Standard Line Bodies*

Code	Part No	Material	Pressure Rating	Weight
FH082-AS6	03011409	Aluminum, anodized	3500 psi (245 bar)	0.34 lbs (0.15 kg)
FH082-SS6	00560917	Steel, Zinc plated	6000 psi (420 bar)	1.0 lbs (0.45 kg)

*Please refer to Line Bodies & Cavities section for details

SOLENOID VALVES

WS10Y-01

Poppet Type, Normally Open, Pilot Operated

Up to 20 gpm (75 l/min) • 5000 psi (350 bar)

Hydraulic Symbol

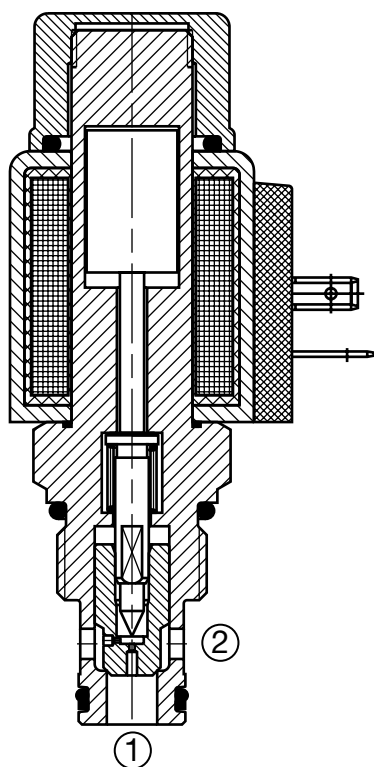
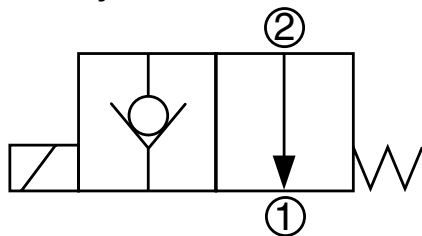

Description

A screw-in cartridge, solenoid operated, 2-way, 2 position, normally open, pilot operated, poppet type intended for use as a uni-directional blocking or load holding device in hydraulic circuits requiring low internal leakage.

Operation

When de-energized the WS10Y allows flow from port 2 to port 1, while flow from port 1 to port 2 is severely restricted. If this flow path is required see model WS10YR. When energized the valve's poppet closes on its seat, blocking flow from port 2 to port 1. Flow from port 1 to port 2 is allowed when hydraulic pressure generated force (36 to 145 psi (2.5 to 10 bar)) overcomes solenoid force.

Operation of Manual Override Option: To override, push and hold the override button. The override is not detented. The manual override option is intended for emergency use, not for continuous duty operation.

Features

- Push type manual override button, protected by rubber cap

Specifications

Operating Pressure	5000 psi (350 bar)
Nominal Flow	20 gpm (75 l/min)
Internal Leakage	Leaktight, less than 5 drops/min. at 5000 psi (0.25 cc/min at 350 bar)
Fluid Operating Temp. Range	-4° to 248°F (-20° to 120°C) (Consult factory for usage at temp. outside range.)
Ambient Temperature Range	-4° to 140°F (-20° to 60°C)
Coil Duty Rating	Continuous from 85% to 115% of nominal voltage
Current Draw @ 68°F (20°C)	1.5 A at 12VDC; 0.8 A at 24VDC
Min. Pull-in Voltage @ 68°F (20°C)	85% of nominal @ 5000 psi (350 bar)
Response Time (typical)	Energized 55 ms De-energized 35 ms
Fluid Compatibility	Mineral-based or synthetics with lubricating properties
Viscosity	50 to 2000 SUS (7.4 to 420 cSt)
Filtration	21/19/16 or cleaner (per ISO 4406). Use with filter rated $\beta_{10} \geq 200$.
Installation	No orientation restrictions
Cavity	FC10-2 (see <i>Line Bodies & Cavities</i> section)
Cavity Tools	Rougher: 02580274 Finisher: 02580247
Cartridge Weight	0.40 Lbs. (0.182 kg)
Coil Weight	0.42 Lbs. (0.190 kg)
Cartridge Material	Steel with hardened work surfaces. Zinc-plated exposed surfaces. Buna N or Viton® o-rings. PTFE back-up rings.
Coil Material	Class N high temperature magnet wire, steel shell, polyamid encapsulation.
Seal Kits	Buna-N FS102-N P/N: 03033872 Viton® FS102-V P/N: 03051757

Performance

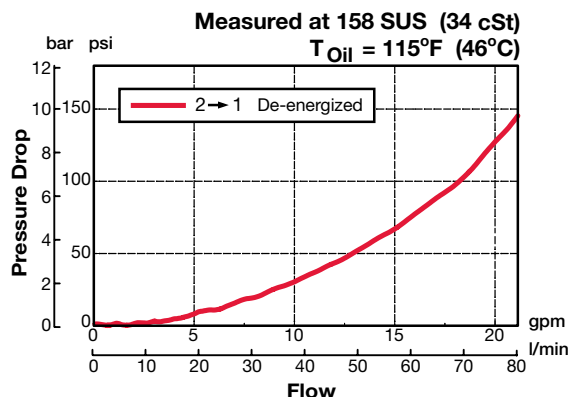

Dimensions

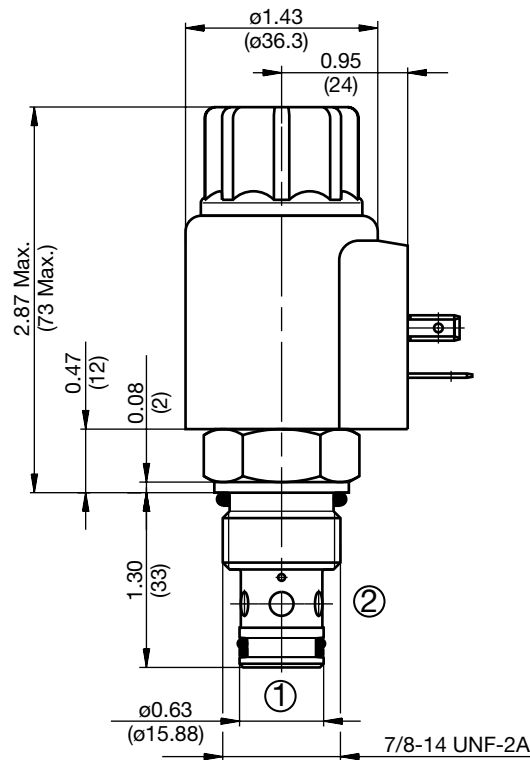
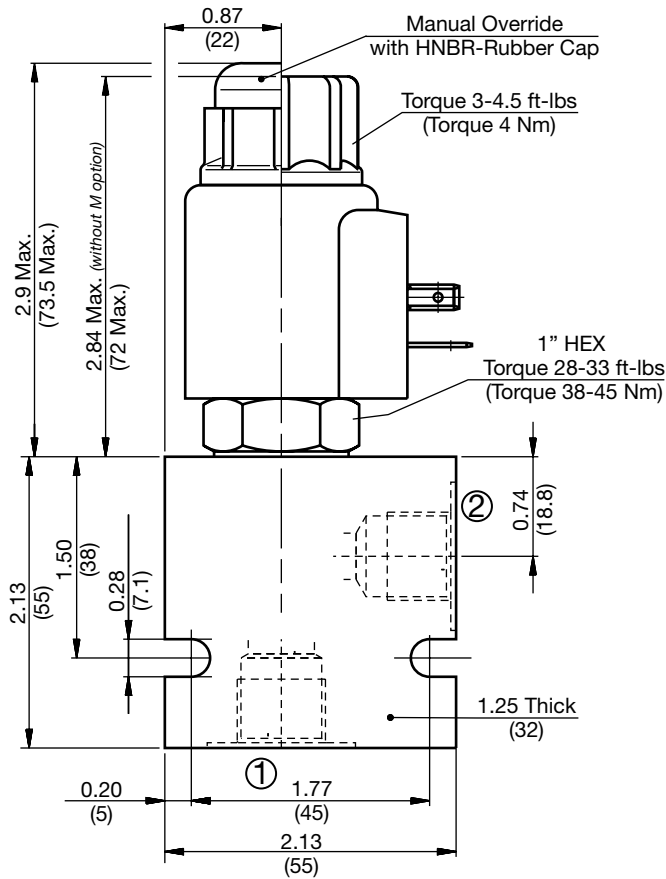

All measurements in inches (mm).
Subject to technical modifications

PN#02087369 / 10.19 / CHD1110-1389

Model Code

WS10Y-01 M-C-N-24 DS

Valve Model	WS10Y-01
Override Option	M
Body & Ports	C
Seals	N
Coil Voltage	24
Coil Connector	DS

blank = No manual override
M = Manual override, push type
C = Cartridge only
AS8 = SAE-8 Ports, aluminum body
SS8 = SAE-8 Ports, steel body
N = Buna-N
V = Viton®
0 = No coil, cartridge only
12 = 12 VDC
24 = 24 VDC
36 = 36 VDC
110 = 110 VDC (only available with connector DG)
24 = 24 VAC
115 = 115 VAC (AC coils internally full wave rectified)
230 = 230 VAC
DG = EN 175301-803-A
DS = Dual spade (SAEJ858a)*
DL = Leadwires (2) - 18" long (46 cm)*
DW = WeatherPak™ on leadwires - 9.5" long (24 cm)*
DN = Deutsch™ DT04-2P, molded, axial (IP69K Rated)*
DT = Amp Junior Timer™, molded, radial mount*
AG = EN 175301-803-A

Coil Model 40-1836

For other coil connector types consult factory

*Coils with internal diode are available, consult factory.

Standard Line Bodies*

Code	Part No	Material	Pressure Rating	Weight
FH102-AS8	03037778	Aluminum, anodized	3500 psi (245 bar)	0.40 lbs (0.18 kg)
FH102-SS8	03037612	Steel, Zinc plated	6000 psi (420 bar)	1.16 lbs (0.53 kg)

*Please refer to Line Bodies & Cavities section for details

SOLENOID VALVES

WS12Y-01

Poppet Type, Normally Open, Pilot Operated

Up to 29 gpm (110 l/min) • 5000 psi (350 bar)

Hydraulic Symbol

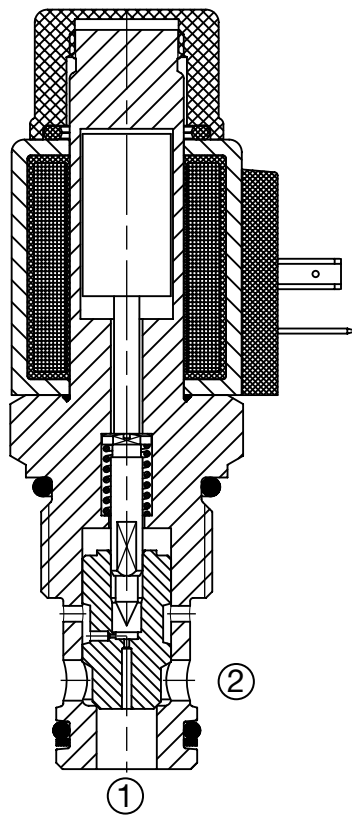
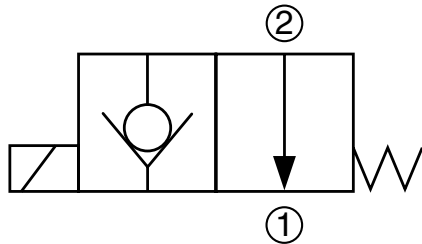

Description

A screw-in cartridge, solenoid operated, 2-way, 2 position, normally open, pilot operated, poppet type intended for use as a uni-directional blocking or load holding device in hydraulic circuits requiring low internal leakage.

Operation

When de-energized the WS12Y allows flow from port 2 to port 1, while flow from port 1 to port 2 is severely restricted. If this flow path is required see model WS12YR. When energized the valve's poppet closes on its seat, blocking flow from port 2 to port 1. Flow from port 1 to port 2 is allowed when hydraulic pressure generated force (22 to 94 psi (1.5 to 6.5 bar)) overcomes solenoid force.

Operation of Manual Override Option: To override, push and hold the override button. The override is not detented. The manual override option is intended for emergency use, not for continuous duty operation.

Features

- Push type manual override button, protected by rubber cap

Specifications

Operating Pressure	5000 psi (350 bar)
Nominal Flow	29 gpm (110 l/min)
Internal Leakage	Leaktight, less than 5 drops/min. at 5000 psi (0.25 cc/min at 350 bar)
Fluid Operating Temp. Range	-4° to 248°F (-20° to 120°C) (Consult factory for usage at temp. outside range.)
Ambient Temperature Range	-4° to 140°F (-20° to 60°C)
Coil Duty Rating	Continuous from 85% to 115% of nominal voltage
Current Draw @ 68°F (20°C)	1.5 A at 12VDC; 0.8 A at 24VDC
Min. Pull-in Voltage @ 68°F (20°C)	85% of nominal @ 5000 psi (350 bar)
Response Time (typical)	Energized 90 ms De-energized 25 ms
Fluid Compatibility	Mineral-based or synthetics with lubricating properties
Viscosity	50 to 2000 SUS (7.4 to 420 cSt)
Filtration	21/19/16 or cleaner (per ISO 4406). Use with filter rated $\beta_{10} \geq 200$.
Installation	No orientation restrictions
Cavity	FC12-2 (see Line Bodies & Cavities section)
Cavity Tools	Rougher: 02580667 Finisher: 02580668
Cartridge Weight	0.60 Lbs. (0.27 kg)
Coil Weight	0.42 Lbs. (0.19 kg)
Cartridge Material	Steel with hardened work surfaces. Zinc-plated exposed surfaces. Buna N or Viton® o-rings. PTFE back-up rings.
Coil Material	Class N high temperature magnet wire, steel shell, polyamid encapsulation.
Seal Kits	Buna-N FS122-N P/N: 03071298 Viton® FS122-V P/N: 03071299

Performance

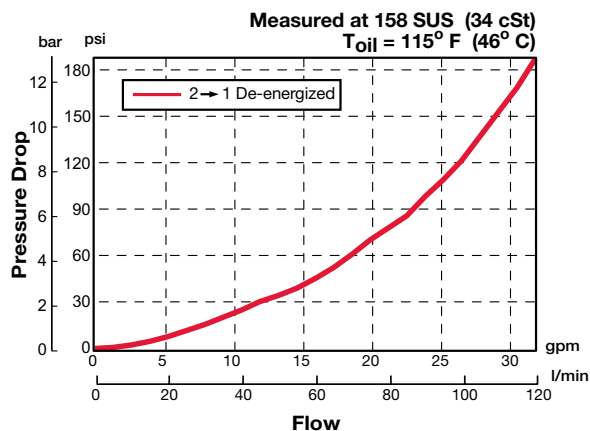

Dimensions

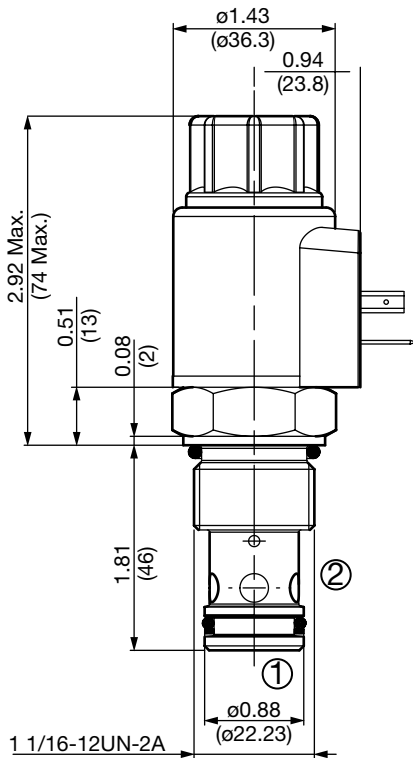
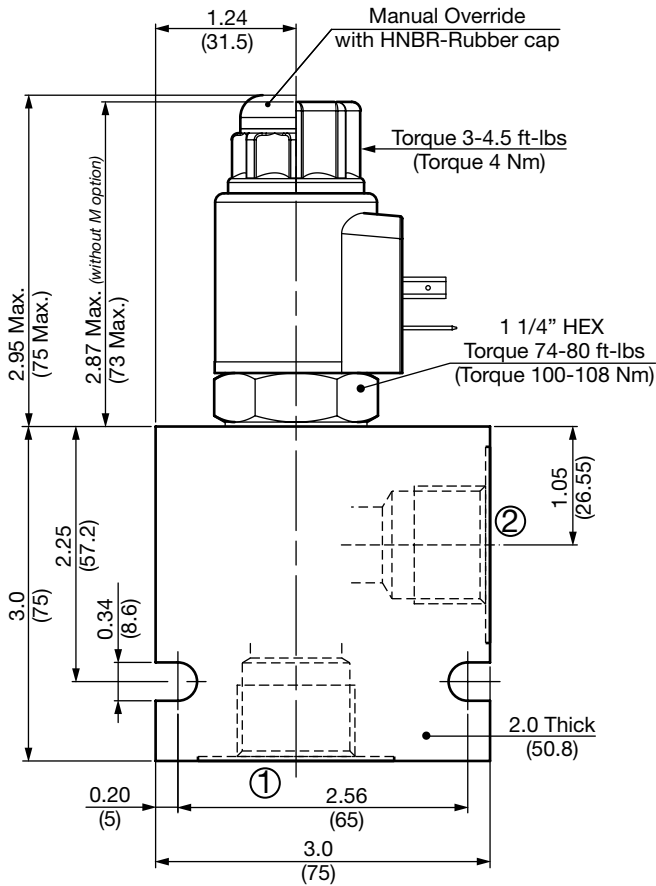

All measurements in inches (mm).
Subject to technical modifications

Model Code

WS12Y-01 M-C-N-24 DS

- Valve Model** _____
- Override Option** _____
blank = No manual override
M = Manual override, push type
- Body & Ports** _____
C = Cartridge only
AS12 = SAE-12 Ports, aluminum body
SS12 = SAE-12 Ports, steel body
- Seals** _____
N = Buna-N
V = Viton®
- Coil Voltage** _____
0 = No coil, cartridge only
- DC** [12 = 12 VDC
24 = 24 VDC
36 = 36 VDC
110 = 110 VDC (only available with connector DG)
- AC** [24 = 24 VAC
115 = 115 VAC (AC coils internally full wave rectified)
230 = 230 VAC
- Coil connector** _____
DC [DG = EN 175301-803-A
DS = Dual spade (SAEJ858a)*
DL = Leadwires (2) - 18" long (46 cm)*
DW = WeatherPak™ on leadwires - 9.5" long (24 cm)*
DN = Deutsch™ DT04-2P, molded, axial (IP69K Rated)*
DT = Amp Junior Timer™, molded, radial mount*
- AC AG = EN 175301-803-A

Coil Model 40-1836

For other coil connector types consult factory

*Coils with internal diode are available, consult factory.

Standard Line Bodies*

Code	Part No	Material	Pressure Rating	Weight
FH122-AS12	03053845	Aluminum, anodized	3500 psi (245 bar)	1.39 lbs (0.63 kg)
FH122-SS12	03053772	Steel, Zinc plated	6000 psi (420 bar)	4.16 lbs (1.89 kg)

*Please refer to Line Bodies & Cavities section for details

SOLENOID VALVES

WS16Y-01

Poppet Type, Normally Open, Pilot Operated

Up to 40 gpm (150 l/min) • 5000 psi (350 bar)

Hydraulic Symbol

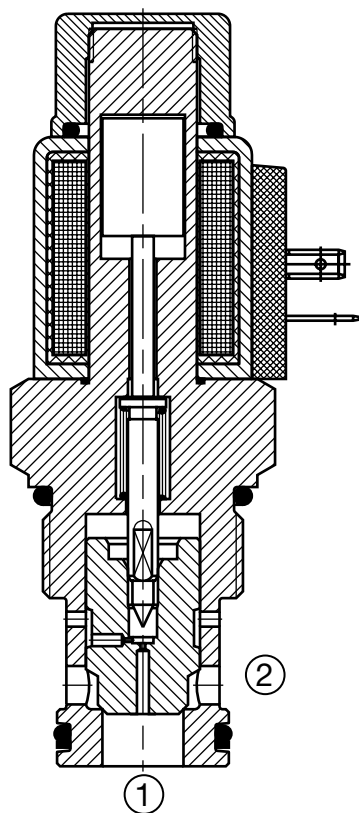
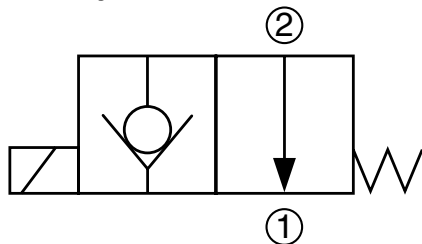

Description

A screw-in cartridge, solenoid operated, 2-way, 2 position, normally open, pilot operated, poppet type intended for use as a uni-directional blocking or load holding device in hydraulic circuits requiring low internal leakage.

Operation

When de-energized the WS16Y allows flow from port 2 to port 1, while flow from port 1 to port 2 is severely restricted. If this flow path is required see model WS16YR. When energized the valve's poppet closes on its seat, blocking flow from port 2 to port 1. Flow from port 1 to port 2 is allowed when hydraulic pressure generated force (15 to 45 psi (1 to 3 bar)) overcomes solenoid force.

Operation of Manual Override Option: To override, push and hold the override button. The override is not detented. The manual override option is intended for emergency use, not for continuous duty operation.

Features

- Push type manual override button, protected by rubber cap

Specifications

Operating Pressure	5000 psi (350 bar)		
Nominal Flow	40 gpm at 4060 psi (150 l/min at 280 bar) 26 gpm at 5000 psi (100 l/min at 350 bar)		
Internal Leakage	Leaktight, less than 5 drops/min. at 5000 psi (0.25 cc/min at 350 bar)		
Fluid Operating Temp. Range	-4° to 248°F (-20° to 120°C) <i>(Consult factory for usage at temp. outside range.)</i>		
Ambient Temperature Range	-4° to 140°F (-20° to 60°C)		
Coil Duty Rating	Continuous from 85% to 115% of nominal voltage		
Current Draw @ 68°F (20°C)	1.5 A at 12VDC; 0.8 A at 24VDC		
Min. Pull-in Voltage @ 68°F (20°C)	85% of nominal @ 5000 psi (350 bar)		
Response Time (typical)	Energized	150 ms	
	De-energized	35 ms	
Fluid Compatibility	Mineral-based or synthetics with lubricating properties		
Viscosity	50 to 2000 SUS (7.4 to 420 cSt)		
Filtration	21/19/16 or cleaner (per ISO 4406). Use with filter rated $\beta_{10} \geq 200$.		
Installation	No orientation restrictions		
Cavity	FC16-2 (see <i>Line Bodies & Cavities</i> section)		
Cavity Tools	Rougher:	02580250	
	Finisher:	02580251	
Cartridge Weight	1.37 Lbs. (0.62 kg)		
Coil Weight	0.42 Lbs. (0.19 kg)		
Cartridge Material	Steel with hardened work surfaces. Zinc-plated exposed surfaces. Buna N or Viton® o-rings. PTFE back-up rings.		
Coil Material	Class N high temperature magnet wire, steel shell, polyamid encapsulation.		
Seal Kits	Buna-N	FS162-N	P/N: 03052427
	Viton®	FS162-V	P/N: 03051758

Performance

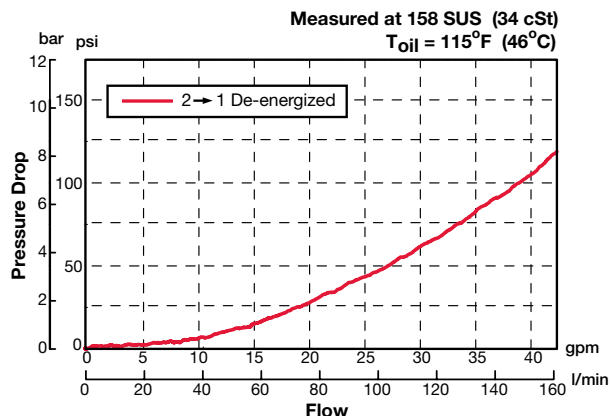

Dimensions

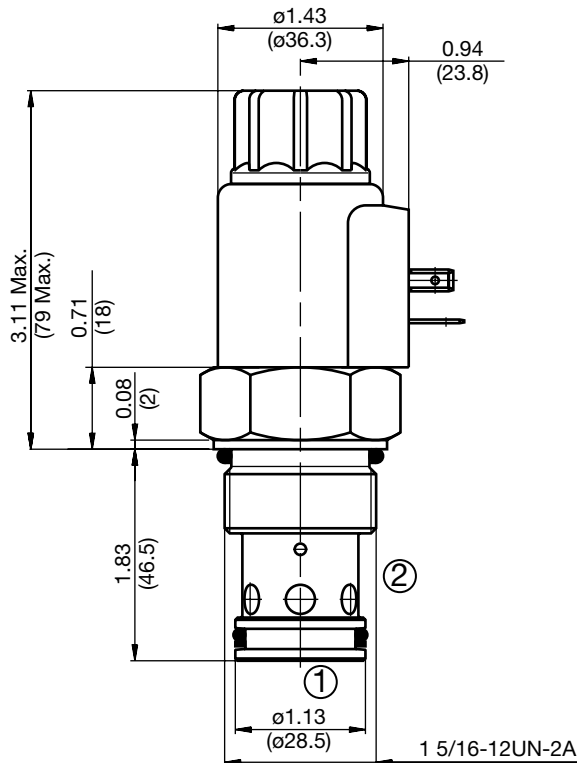
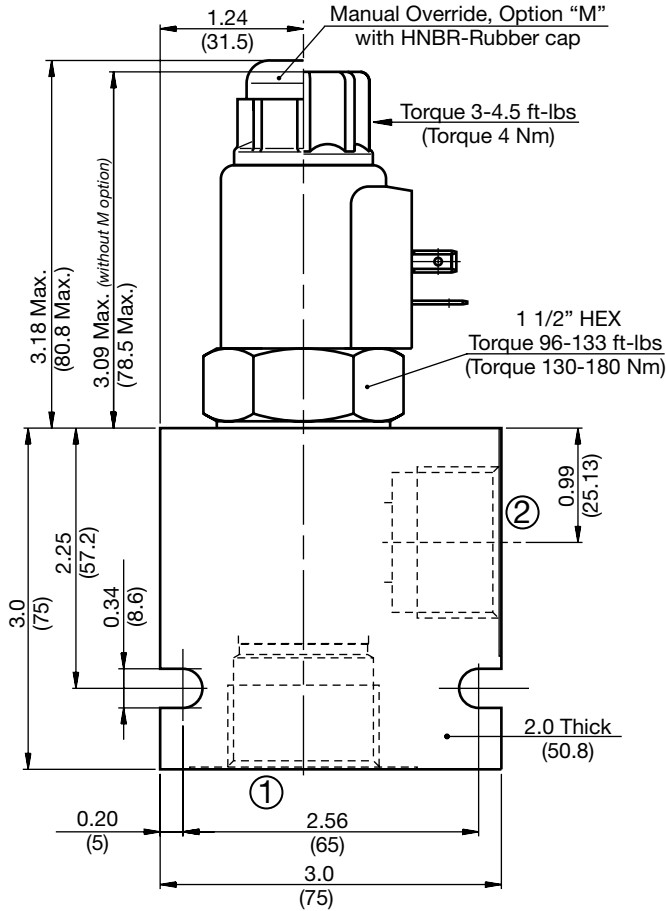

All measurements in inches (mm).
Subject to technical modifications

Model Code

WS16Y-01 M-C-N-24 DS

Valve Model

Override Option

blank = No manual override
M = Manual override, push type

Body & Ports

C = Cartridge only
AS16 = SAE-16 Ports, aluminum body
SS16 = SAE-16 Ports, steel body

Seals

N = Buna-N
V = Viton®

Coil Voltage

0 = No coil, cartridge only

DC

12 = 12 VDC
24 = 24 VDC
36 = 36 VDC
110 = 110 VDC (only available with connector DG)

AC

24 = 24 VAC
115 = 115 VAC (AC coils internally full wave rectified)
230 = 230 VAC

Coil Connector

DC DG = EN 175301-803-A
DS = Dual spade (SAEJ858a)*
DL = Leadwires (2) - 18" long (46 cm)*
DW = WeatherPak™ on leadwires - 9.5" long (24 cm)*
DN = Deutsch™ DT04-2P, molded, axial (IP69K Rated)*
DT = Amp Junior Timer™, molded, radial mount*

AC AG = EN 175301-803-A

Coil Model 40-1836

For other coil connector types consult factory

*Coils with internal diode are available, consult factory.

Standard Line Bodies*

Code	Part No	Material	Pressure Rating	Weight
FH162-AS16	03037195	Aluminum, anodized	3500 psi (245 bar)	1.2 lbs (0.55 kg)
FH162-SS16	03032655	Steel, Zinc plated	6000 psi (420 bar)	3.56 lbs (1.62 kg)

*Please refer to Line Bodies & Cavities section for details

SOLENOID VALVES

WS08Y-30

Poppet Type, Normally Open, Pilot Operated

Up to 8 gpm (30 l/min) • 5000 psi (350 bar)

Hydraulic Symbol

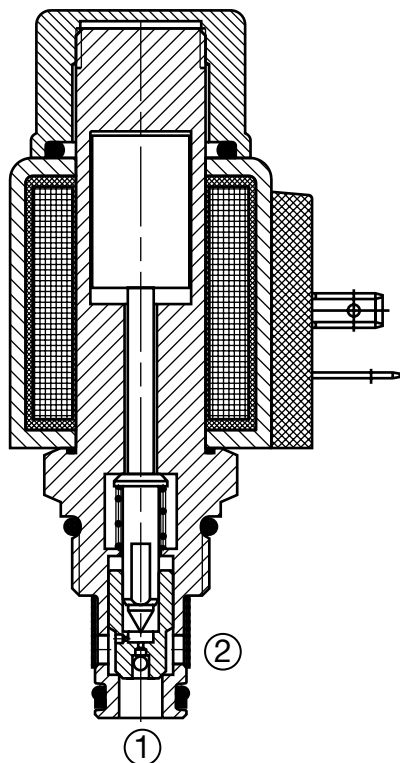
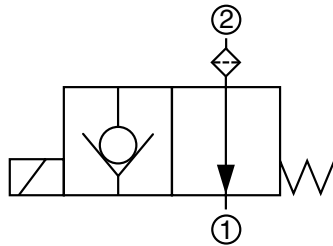

Description

A screw-in cartridge, solenoid operated, 2-way, 2 position, normally open, pilot operated, poppet type, with filter screen on inlet port, intended for use as a uni-directional blocking or load holding device in hydraulic circuits requiring low internal leakage.

Operation

When de-energized the WS08Y allows flow from port 2 to port 1, while flow from port 1 to port 2 is severely restricted. If this flow path is required see model WS08YR. When energized the valve's poppet closes on its seat, blocking flow from port 2 to port 1. Flow from port 1 to port 2 is allowed when hydraulic pressure generated force (130 to 290 psi (9 to 20 bar)) overcomes solenoid force.

Operation of Manual Override Option: To override, push and hold the override button. The override is not detented. The manual override option is intended for emergency use, not for continuous duty operation.

Features

- Filter screen on the inlet port for protection from contamination getting inside the cartridge
- Push type manual override button, protected by rubber cap

Specifications

Operating Pressure	5000 psi (350 bar)
Nominal Flow	8 gpm (30 l/min)
Internal Leakage	Leaktight, less than 5 drops/min. at 5000 psi (0.25 cc/min at 350 bar)
Fluid Operating Temp. Range	-4° to 248°F (-20° to 120°C) (Consult factory for usage at temp. outside range.)
Ambient Temperature Range	-4° to 140°F (-20° to 60°C)
Coil Duty Rating	Continuous from 85% to 115% of nominal voltage
Current Draw @ 68°F (20°C)	1.5 A at 12VDC; 0.8 A at 24VDC
Min. Pull-in Voltage @ 68°F (20°C)	85% of nominal @ 5000 psi (350 bar)
Response Time (typical)	Energized: 50ms De-Energized: 35ms
Fluid Compatibility	Mineral-Based or Synthetics with lubricating properties.
Viscosity	50 to 2000 SUS (7.4 to 420 cSt)
Filtration	21/19/16 or cleaner per (ISO 4406). Use with filter rated $\beta_{10} \geq 200$.
Filter screen	300 μ m mesh
Installation	No orientation restrictions
Cavity	FC08-2 (see Line Bodies and Cavities section)
Cavity Tools	Rougher: 02580090 Finisher: 02580091
Cartridge Weight	0.31 Lbs. (0.14 kg)
Coil Weight	0.42 Lbs. (0.19 kg)
Cartridge Material	Steel with hardened work surfaces. Zinc plated exposed surfaces. Buna N or Viton® o-rings. PTFE back-up rings.
Coil Material	Class N high temperature magnet wire, steel shell, polyamide encapsulation.
Seal Kits	Buna-N FS082-N P/N: 03033920 Viton® FS082-V P/N: 03051756

Performance

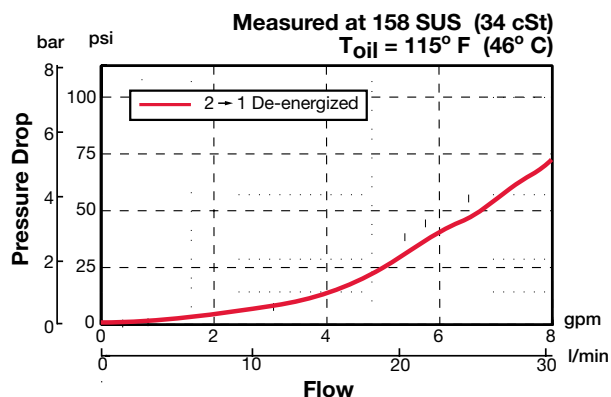

Dimensions

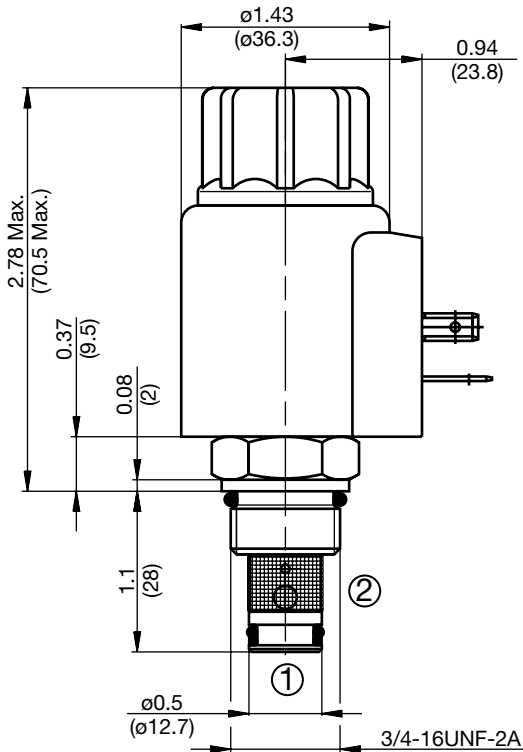
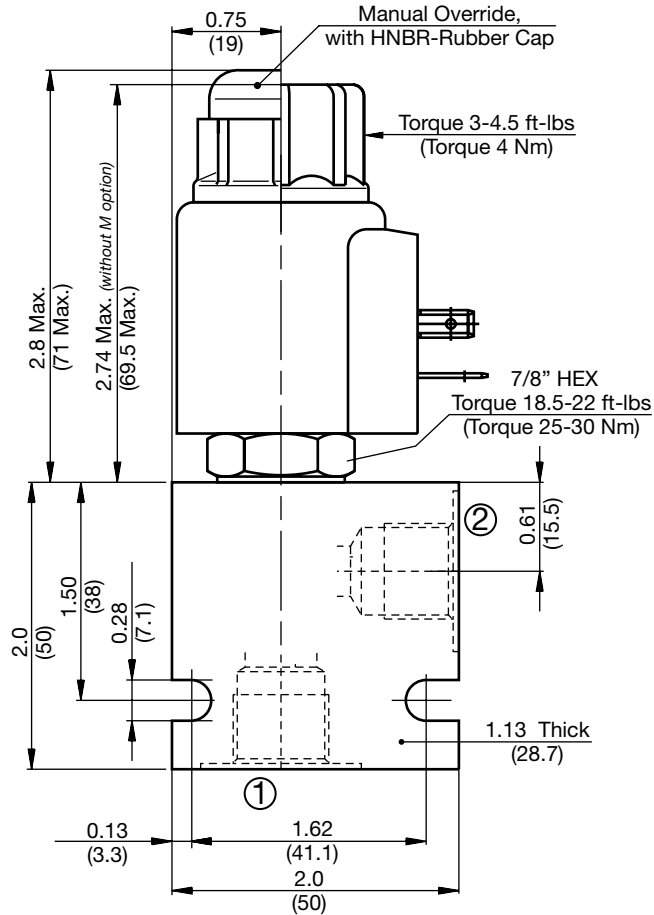

All measurements in inches (mm).
Subject to technical modifications

PN#02087369 / 10.19 / CHD1110-1389

Model Code

WS08Y-30 M-C-N-24 DS

- Valve Model** _____
- Override Option** _____
 blank = No manual override
 M = Manual override, push type
- Body & Ports** _____
 C = Cartridge only
 AS6 = SAE-6 Ports, aluminum body
 SS6 = SAE-6 Ports, steel body
- Seals** _____
 N = Buna-N
 V = Viton®
- Coil Voltage** _____
 0 = No coil, cartridge only
- DC** _____
 12 = 12 VDC
 24 = 24 VDC
 36 = 36 VDC
 110 = 110 VDC (only available with connector DG)
- AC** _____
 24 = 24 VAC
 115 = 115 VAC (AC coils internally full wave rectified)
 230 = 230 VAC
- Coil Connector** _____
 DC DG = EN 175301-803-A
 DS = Dual spade (SAEJ858a)*
 DL = Leadwires (2) - 18" long (46 cm)*
 DW = WeatherPak™ on leadwires - 9.5" long (24 cm)*
 DN = Deutsch™ DT04-2P, molded, axial (IP69K Rated)*
 DT = Amp Junior Timer™, molded, radial mount*
- AC AG** = EN 175301-803-A

Coil Model 40-1836

For other coil connector types consult factory

*Coils with internal diode are available, consult factory.

Standard Line Bodies*

Code	Part No	Material	Pressure Rating	Weight
FH082-AS6	03011409	Aluminum, anodized	3500 psi (245 bar)	0.34 lbs (0.15 kg)
FH082-SS6	00560917	Steel, Zinc plated	6000 psi (420 bar)	1.0 lbs (0.45 kg)

*Please refer to Line Bodies & Cavities section for details

SOLENOID VALVES

WS08YR-01

Poppet Type, Normally Open, Pilot Operated, Free Reverse Flow

Up to 10 gpm (38 l/min) • 5000 psi (350 bar)

Hydraulic Symbol

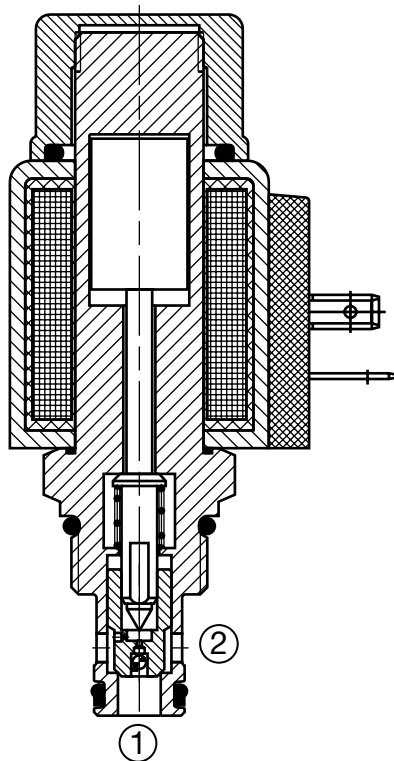
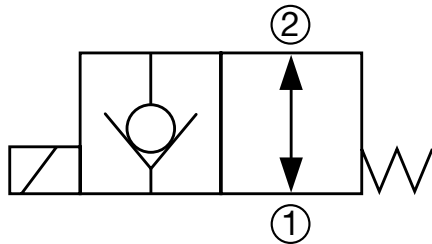

Description

A screw-in cartridge, solenoid operated, 2-way, 2 position, normally open, pilot operated, poppet type intended for use as a uni-directional blocking or load holding device in hydraulic circuits requiring low internal leakage.

Operation

When de-energized the WS08YR allows flow from port 2 to port 1 and from port 1 to port 2. When energized the valve's poppet closes on its seat, blocking flow from port 2 to port 1. Flow from port 1 to port 2 is allowed when hydraulic pressure generated force (130 to 290 psi (9 to 20 bar)) overcomes solenoid force.

Operation of Manual Override Option: To override, push and hold the override button. The override is not detented. The manual override option is intended for emergency use, not for continuous duty operation.

Features

- Push type manual override button, protected by rubber cap
- Free reverse flow

Specifications

Operating Pressure	5000 psi (350 bar)
Nominal Flow	10 gpm (38 l/min)
Internal Leakage	Leaktight, less than 5 drops/min. at 5000 psi (0.25 cc/min at 350 bar)
Fluid Operating Temp. Range	-4° to 248°F (-20° to 120°C) (Consult factory for usage at temp. outside range.)
Ambient Temperature Range	-4° to 140°F (-20° to 60°C)
Coil Duty Rating	Continuous from 85% to 115% of nominal voltage
Current Draw @ 68°F (20°C)	1.5 A at 12VDC; 0.8 A at 24VDC
Min. Pull-in Voltage @ 68°F (20°C)	85% of nominal @ 5000 psi (350 bar)
Response Time (typical)	Energized: 50ms De-Energized: 35ms
Fluid Compatibility	Mineral-Based or Synthetics with lubricating properties.
Viscosity	50 to 2000 SUS (7.4 to 420 cSt)
Filtration	21/19/16 or cleaner per (ISO 4406). Use with filter rated $\beta_{10} \geq 200$.
Installation	No orientation restrictions
Cavity	FC08-2 (see Line Bodies and Cavities section)
Cavity Tools	Rougher: 02580090 Finisher: 02580091
Cartridge Weight	0.31 Lbs. (0.14 kg)
Coil Weight	0.42 Lbs. (0.19 kg)
Cartridge Material	Steel with hardened work surfaces. Zinc plated exposed surfaces. Buna N or Viton® o-rings. PTFE back-up rings.
Coil Material	Class N high temperature magnet wire, steel shell, polyamid encapsulation.
Seal Kits	Buna-N FS082-N P/N: 03033920 Viton® FS082-V P/N: 03051756

Performance

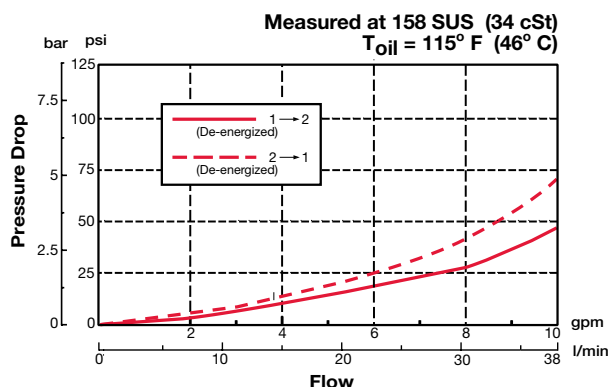

Dimensions

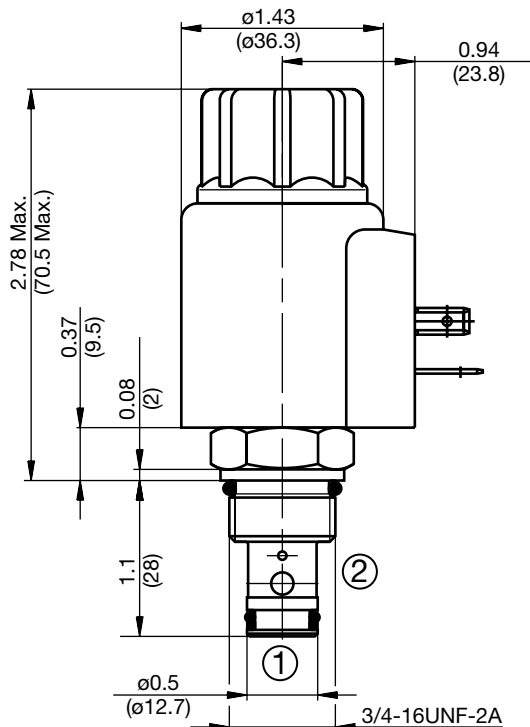
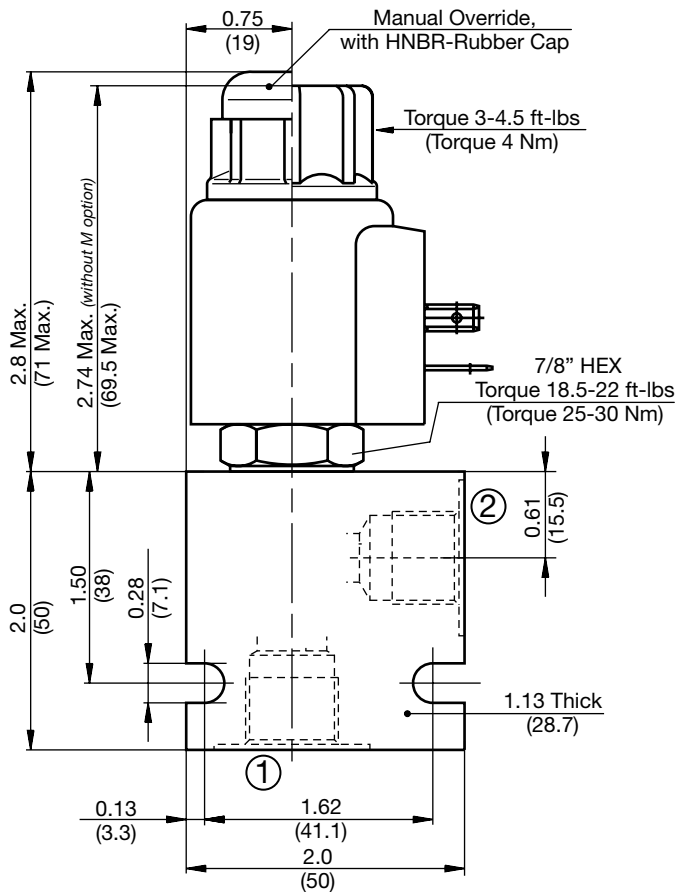

All measurements in inches (mm).
Subject to technical modifications

Model Code

WS08YR-01 M-C-N-24 DS

- Valve Model** _____
- Override Option** _____
blank = No manual override
M = Manual override, push type
- Body & Ports** _____
C = Cartridge only
AS6 = SAE-6 Ports, aluminum body
SS6 = SAE-6 Ports, steel body
- Seals** _____
N = Buna-N
V = Viton®
- Coil Voltage** _____
0 = No coil, cartridge only
- DC** _____
12 = 12 VDC
24 = 24 VDC
36 = 36 VDC
110 = 110 VDC (only available with connector DG)
- AC** _____
24 = 24 VAC
115 = 115 VAC (AC coils internally full wave rectified)
230 = 230 VAC
- Coil Connector** _____
DC DG = EN 175301-803-A
DS = Dual spade (SAEJ858a)*
DL = Leadwires (2) - 18" long (46 cm)*
DW = WeatherPak™ on leadwires - 9.5" long (24 cm)*
DN = Deutsch™ DT04-2P, molded, axial (IP69K Rated)*
DT = Amp Junior Timer™, molded, radial mount*
- AC AG = EN 175301-803-A

Coil Model 40-1836

For other coil connector types consult factory

*Coils with internal diode are available, consult factory.

Standard Line Bodies*

Code	Part No	Material	Pressure Rating	Weight
FH082-AS6	03011409	Aluminum, anodized	3500 psi (245 bar)	0.34 lbs (0.15 kg)
FH082-SS6	00560917	Steel, Zinc plated	6000 psi (420 bar)	1.0 lbs (0.45 kg)

*Please refer to Line Bodies & Cavities section for details

SOLENOID VALVES

WS10YR-01

Poppet Type, Normally Open, Pilot Operated, Free Reverse Flow

Up to 20 gpm (75 l/min) • 5000 psi (350 bar)

Hydraulic Symbol

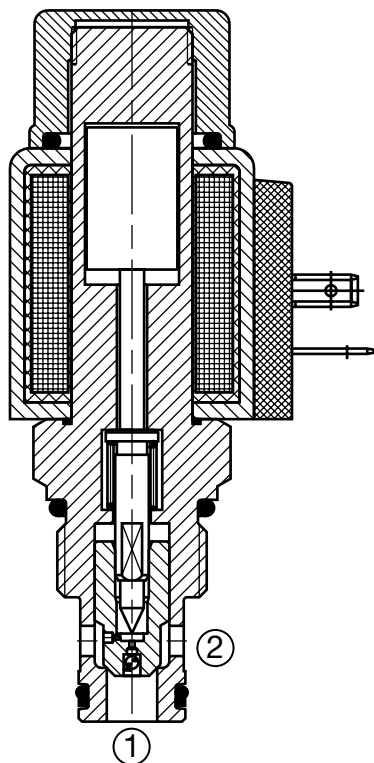
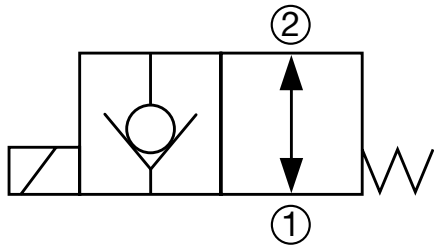

Description

A screw-in cartridge, solenoid operated, 2-way, 2 position, normally open, pilot operated, poppet type intended for use as a uni-directional blocking or load holding device in hydraulic circuits requiring low internal leakage.

Operation

When de-energized the WS10YR allows flow from port 2 to port 1 and from port 1 to port 2. When energized the valve's poppet closes on its seat, blocking flow from port 2 to port 1. Flow from port 1 to port 2 is allowed when hydraulic pressure generated force (130 to 290 psi (9 to 20 bar)) overcomes solenoid force.

Operation of Manual Override Option: To override, push and hold the override button. The override is not detented. The manual override option is intended for emergency use, not for continuous duty operation.

Features

- Push type manual override button, protected by rubber cap
- Free reverse flow

Specifications

Operating Pressure	5000 psi (350 bar)	
Nominal Flow	20 gpm (75 l/min)	
Internal Leakage	Leaktight, less than 5 drops/min. at 5000 psi (0.25 cc/min at 350 bar)	
Fluid Operating Temp. Range	-4° to 248°F (-20° to 120°C) <i>(Consult factory for usage at temp. outside range.)</i>	
Ambient Temperature Range	-4° to 140°F (-20° to 60°C)	
Coil Duty Rating	Continuous from 85% to 115% of nominal voltage	
Current Draw @ 68°F (20°C)	1.5 A at 12VDC; 0.8 A at 24VDC	
Min. Pull-in Voltage @ 68°F (20°C)	85% of nominal @ 5000 psi (350 bar)	
Response Time (typical)	Energized	55 ms
	De-energized	35 ms
Fluid Compatibility	Mineral-based or synthetics with lubricating properties	
Viscosity	50 to 2000 SUS (7.4 to 420 cSt)	
Filtration	21/19/16 or cleaner (per ISO 4406). Use with filter rated $\beta_{10} \geq 200$.	
Installation	No orientation restrictions	
Cavity	FC10-2 (see <i>Line Bodies & Cavities</i> section)	
Cavity Tools	Rougher:	02580274
	Finisher:	02580247
Cartridge Weight	0.40 Lbs. (0.182 kg)	
Coil Weight	0.42 Lbs. (0.190 kg)	
Cartridge Material	Steel with hardened work surfaces. Zinc-plated exposed surfaces. Buna N or Viton® o-rings. PTFE back-up rings.	
Coil Material	Class N high temperature magnet wire, steel shell, polyamid encapsulation.	
Seal Kits	Buna-N	FS102-N P/N: 03033872
	Viton®	FS102-V P/N: 03051757

Performance

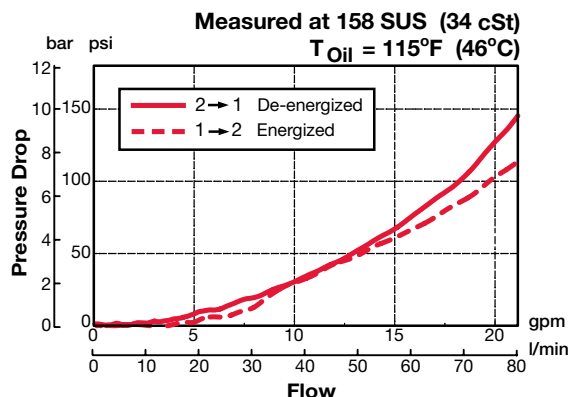

Dimensions

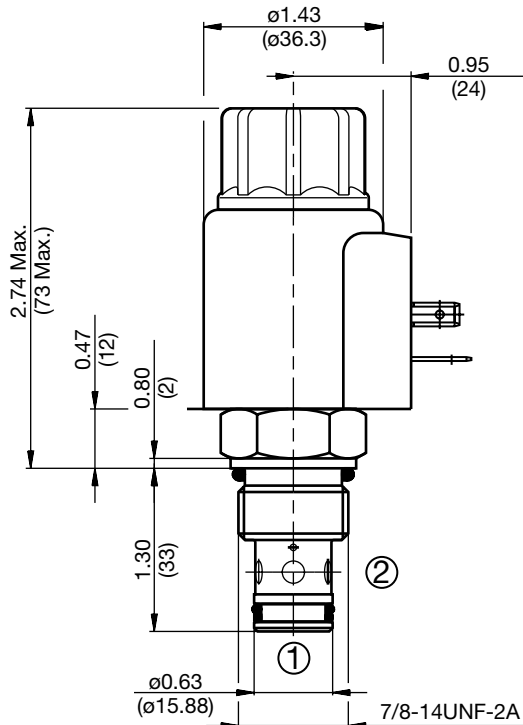
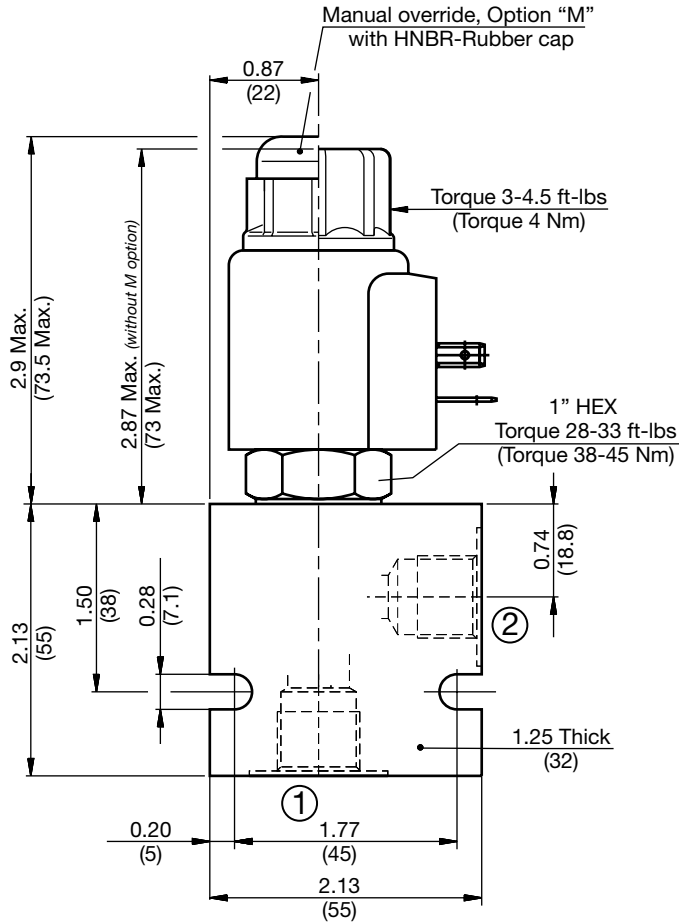

All measurements in inches (mm).
Subject to technical modifications

Model Code

WS10YR-01 M-C-N-24 DS

- Valve Model** _____
- Override Option** _____
 blank = No manual override
 M = Manual override, push type
- Body & Ports** _____
 C = Cartridge only
 AS8 = SAE-8 Ports, aluminum body
 SS8 = SAE-8 Ports, steel body
- Seals** _____
 N = Buna-N
 V = Viton®
- Coil Voltage** _____
- DC 0 = No coil, cartridge only
 12 = 12 VDC
 24 = 24 VDC
 36 = 36 VDC
 110 = 110 VDC (only available with connector DG)
- AC 24 = 24 VAC
 115 = 115 VAC (AC coils internally full wave rectified)
 230 = 230 VAC
- Coil Connector** _____
- DC DG = EN 175301-803-A
 DS = Dual spade (SAEJ858a)*
 DL = Leadwires (2) - 18" long (46 cm)*
 DW = WeatherPak™ on leadwires - 9.5" long (24 cm)*
 DN = Deutsch™ DT04-2P, molded, axial (IP69K Rated)*
 DT = Amp Junior Timer™, molded, radial mount*
- AC AG = EN 175301-803-A

Coil Model 40-1836

For other coil connector types consult factory

*Coils with internal diode are available, consult factory.

Standard Line Bodies*

Code	Part No	Material	Pressure Rating	Weight
FH102-AS8	03037778	Aluminum, anodized	3500 psi (245 bar)	0.40 lbs (0.18 kg)
FH102-SS8	03037612	Steel, Zinc plated	6000 psi (420 bar)	1.16 lbs (0.53 kg)

*Please refer to Line Bodies & Cavities section for details

SOLENOID VALVES

WS12YR-01

Poppet Type, Normally Open, Pilot Operated, Free Reverse Flow

Up to 29 gpm (110 l/min) • 5000 psi (350 bar)

Hydraulic Symbol

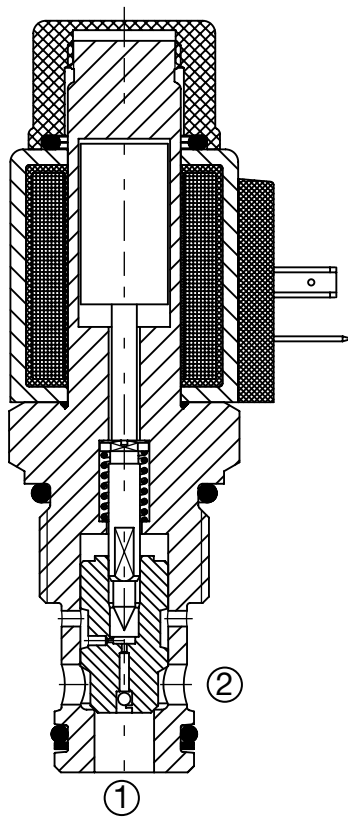
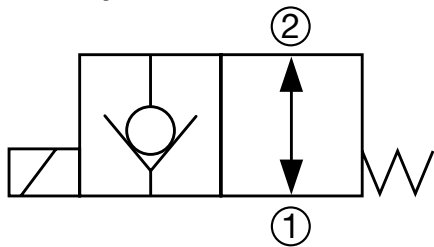

Description

A screw-in cartridge, solenoid operated, 2-way, 2 position, normally open, pilot operated, poppet type intended for use as a uni-directional blocking or load holding device in hydraulic circuits requiring low internal leakage.

Operation

When de-energized the WS12YR allows flow from port 2 to port 1 and from port 1 to port 2. When energized the valve's poppet closes on its seat, blocking flow from port 2 to port 1. Flow from port 1 to port 2 is allowed when hydraulic pressure generated force (22 to 94 psi (1.5 to 6.5 bar)) overcomes solenoid force.

Operation of Manual Override Option: To override, push and hold the override button. The override is not detented. The manual override option is intended for emergency use, not for continuous duty operation.

Features

- Push type manual override button, protected by rubber cap
- Free reverse flow

Specifications

Operating Pressure	5000 psi (350 bar)
Nominal Flow	29 gpm (110 l/min)
Internal Leakage	Leaktight, less than 5 drops/min. at 5000 psi (0.25 cc/min at 350 bar)
Fluid Operating Temp. Range	-4° to 248°F (-20° to 120°C) (Consult factory for usage at temp. outside range.)
Ambient Temperature Range	-4° to 140°F (-20° to 60°C)
Coil Duty Rating	Continuous from 85% to 115% of nominal voltage
Current Draw @ 68°F (20°C)	1.5 A at 12VDC; 0.8 A at 24VDC
Min. Pull-in Voltage @ 68°F (20°C)	85% of nominal @ 5000 psi (350 bar)
Response Time (typical)	Energized 90 ms De-energized 25 ms
Fluid Compatibility	Mineral-based or synthetics with lubricating properties
Viscosity	50 to 2000 SUS (7.4 to 420 cSt)
Filtration	21/19/16 or cleaner (per ISO 4406). Use with filter rated $\beta_{10} \geq 200$.
Installation	No orientation restrictions
Cavity	FC12-2 (see Line Bodies & Cavities section)
Cavity Tools	Rougher: 02580667 Finisher: 02580668
Cartridge Weight	0.60 Lbs. (0.27 kg)
Coil Weight	0.42 Lbs. (0.19 kg)
Cartridge Material	Steel with hardened work surfaces. Zinc-plated exposed surfaces. Buna N or Viton® o-rings. PTFE back-up rings.
Coil Material	Class N high temperature magnet wire, steel shell, polyamid encapsulation.
Seal Kits	Buna-N FS122-N P/N: 03071298 Viton® FS122-V P/N: 03071299

Performance

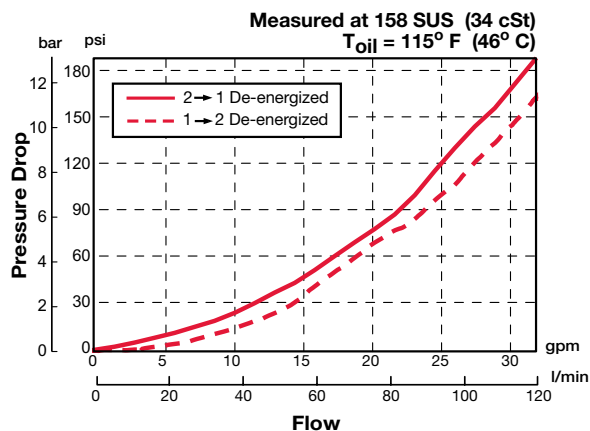

Dimensions

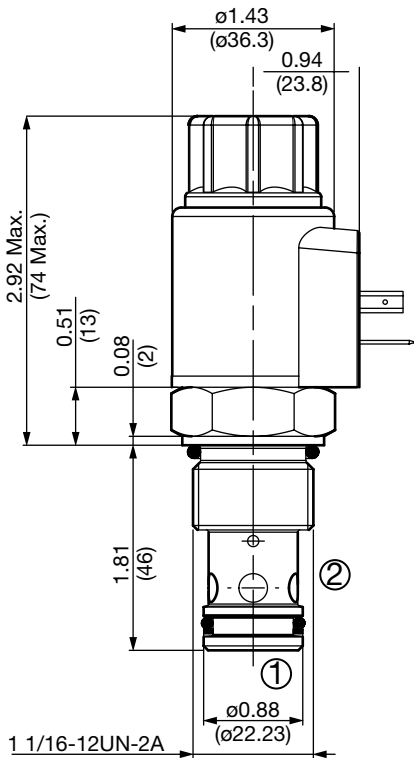
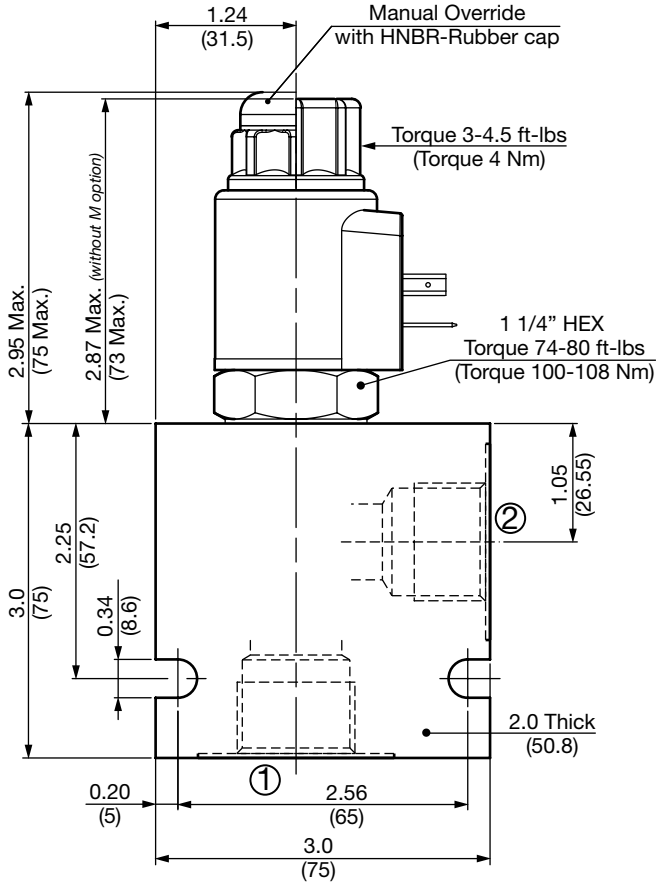

All measurements in inches (mm).
Subject to technical modifications

Model Code

WS12YR-01 M-C-N-24 DS

- Valve Model** _____
- Override Option** _____
 blank = No manual override
 M = Manual override, push type
- Body & Ports** _____
 C = Cartridge only
 AS12 = SAE-12 Ports, aluminum body
 SS12 = SAE-12 Ports, steel body
- Seals** _____
 N = Buna-N
 V = Viton®
- Coil Voltage** _____
 0 = No coil, cartridge only
- DC** _____
 12 = 12 VDC
 24 = 24 VDC
 36 = 36 VDC
 110 = 110 VDC (only available with connector DG)
- AC** _____
 24 = 24 VAC
 115 = 115 VAC (AC coils internally full wave rectified)
 230 = 230 VAC
- Coil connector** _____
 DC DG = EN 175301-803-A
 DS = Dual spade (SAEJ858a)*
 DL = Leadwires (2) - 18" long (46 cm)*
 DW = WeatherPak™ on leadwires - 9.5" long (24 cm)*
 DN = Deutsch™ DT04-2P, molded, axial (IP69K Rated)*
 DT = Amp Junior Timer™, molded, radial mount*
- AC AG** = EN 175301-803-A

Coil Model 40-1836

For other coil connector types consult factory

*Coils with internal diode are available, consult factory.

Standard Line Bodies*

Code	Part No	Material	Pressure Rating	Weight
FH122-AS12	03053845	Aluminum, anodized	3500 psi (245 bar)	1.39 lbs (0.63 kg)
FH122-SS12	03053772	Steel, Zinc plated	6000 psi (420 bar)	4.16 lbs (1.89 kg)

*Please refer to Line Bodies & Cavities section for details

SOLENOID VALVES

WS16YR-01

Poppet Type, Normally Open, Pilot Operated, Free Reverse Flow

Up to 40 gpm (150 l/min) • 5000 psi (350 bar)

Hydraulic Symbol

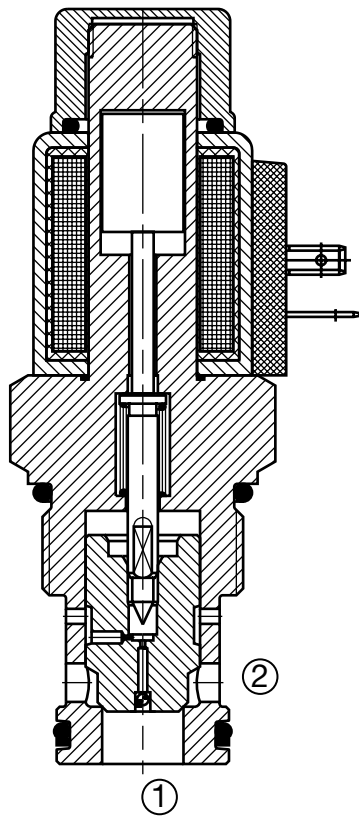
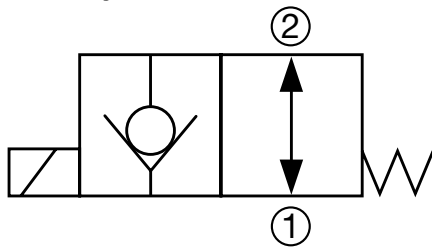

Description

A screw-in cartridge, solenoid operated, 2-way, 2 position, normally open, pilot operated, poppet type intended for use as a uni-directional blocking or load holding device in hydraulic circuits requiring low internal leakage.

Operation

When de-energized the WS16YR allows flow from port 2 to port 1 and from port 1 to port 2. When energized the valve's poppet closes on its seat, blocking flow from port 2 to port 1. Flow from port 1 to port 2 is allowed when hydraulic pressure generated force (15 to 45 psi (1 to 3 bar)) overcomes solenoid force.

Operation of Manual Override Option: To override, push and hold the override button. The override is not detented. The manual override option is intended for emergency use, not for continuous duty operation.

Features

- Push type manual override button, protected by rubber cap
- Free reverse flow

Specifications

Operating Pressure	5000 psi (350 bar)
Nominal Flow	40 gpm at 4060 psi (150 l/min at 280 bar) 26 gpm at 5000 psi (100 l/min at 350 bar)
Internal Leakage	Leaktight, less than 5 drops/min. at 5000 psi (0.25 cc/min at 350 bar)
Fluid Operating Temp. Range	-4° to 248°F (-20° to 120°C) (Consult factory for usage at temp. outside range.)
Ambient Temperature Range	-4° to 140°F (-20° to 60°C)
Coil Duty Rating	Continuous from 85% to 115% of nominal voltage
Current Draw @ 68°F (20°C)	1.5 A at 12VDC; 0.8 A at 24VDC
Min. Pull-in Voltage @ 68°F (20°C)	85% of nominal @ 5000 psi (350 bar)
Response Time (typical)	Energized 150 ms De-energized 35 ms
Fluid Compatibility	Mineral-based or synthetics with lubricating properties
Viscosity	50 to 2000 SUS (7.4 to 420 cSt)
Filtration	21/19/16 or cleaner (per ISO 4406). Use with filter rated $\beta_{10} \geq 200$.
Installation	No orientation restrictions
Cavity	FC16-2 (see Line Bodies & Cavities section)
Cavity Tools	Rougher: 02580250 Finisher: 02580251
Cartridge Weight	1.37 Lbs. (0.62 kg)
Coil Weight	0.42 Lbs. (0.19 kg)
Cartridge Material	Steel with hardened work surfaces. Zinc-plated exposed surfaces. Buna N or Viton® o-rings. PTFE back-up rings.
Coil Material	Class N high temperature magnet wire, steel shell, polyamid encapsulation.
Seal Kits	Buna-N FS162-N P/N: 03052427 Viton® FS162-V P/N: 03051758

Performance

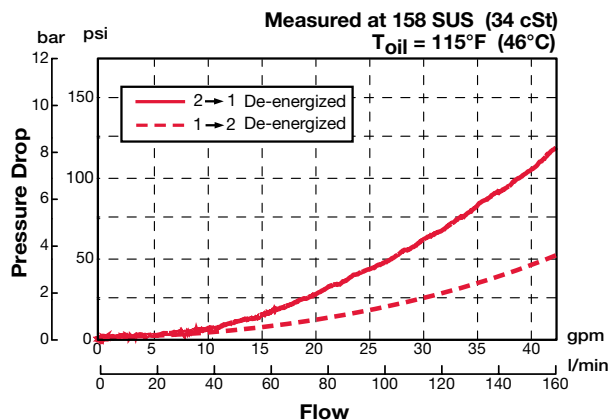

Dimensions

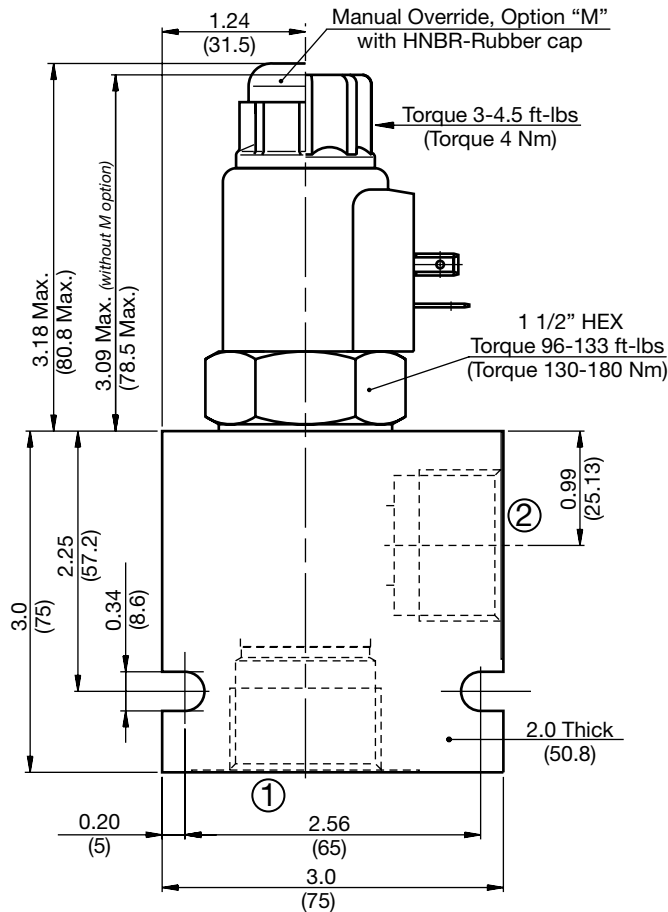

Model Code

WS16YR-01 M-C-N-24 DS

Valve Model

Override Option

blank = No manual override
M = Manual override, push type

Body & Ports

C = Cartridge only
AS16 = SAE-16 Ports, aluminum body
SS16 = SAE-16 Ports, steel body

Seals

N = Buna-N
V = Viton®

Coil Voltage

0 = No coil, cartridge only

DC

12 = 12 VDC
24 = 24 VDC
36 = 36 VDC
110 = 110 VDC (only available with connector DG)

AC

24 = 24 VAC
115 = 115 VAC (AC coils internally full wave rectified)
230 = 230 VAC

Coil Connector

DC DG = EN 175301-803-A
DS = Dual spade (SAEJ858a)*
DL = Leadwires (2) - 18" long (46 cm)*
DW = WeatherPak™ on leadwires - 9.5" long (24 cm)*
DN = Deutsch™ DT04-2P, molded, axial (IP69K Rated)*
DT = Amp Junior Timer™, molded, radial mount*

AC AG = EN 175301-803-A

Coil Model 40-1836

For other coil connector types consult factory

*Coils with internal diode are available, consult factory.

All measurements in inches (mm).
Subject to technical modifications

PN#02087369 / 10.19 / CHD1110-1389

Standard Line Bodies*

Code	Part No	Material	Pressure Rating	Weight
FH162-AS16	03037195	Aluminum, anodized	3500 psi (245 bar)	1.2 lbs (0.55 kg)
FH162-SS16	03032655	Steel, Zinc plated	6000 psi (420 bar)	3.56 lbs (1.62 kg)

*Please refer to Line Bodies & Cavities section for details

SOLENOID VALVES

WS08YR-30

Poppet Type, Normally Open, Pilot Operated, Free Reverse Flow

Up to 8 gpm (30 l/min) • 5000 psi (350 bar)

Hydraulic Symbol

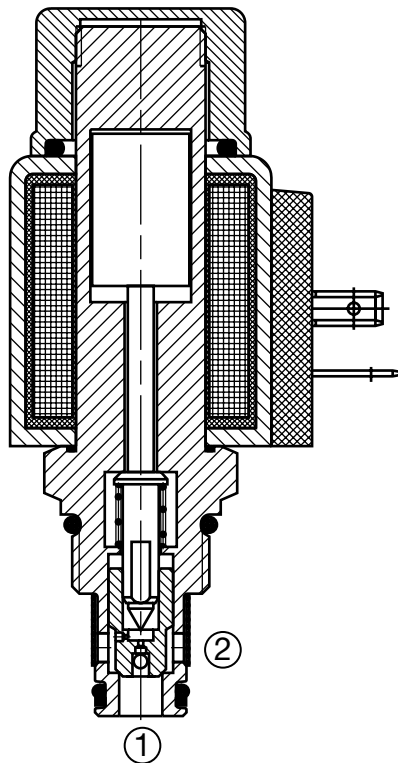
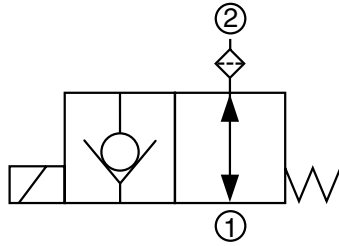

Description

A screw-in cartridge, solenoid operated, 2-way, 2 position, normally open, pilot operated, poppet type, with filter screen on inlet port, intended for use as a uni-directional blocking or load holding device in hydraulic circuits requiring low internal leakage.

Operation

When de-energized the WS08YR allows flow from port 2 to port 1 and from port 1 to port 2. When energized the valve's poppet closes on its seat, blocking flow from port 2 to port 1. Flow from port 1 to port 2 is allowed when hydraulic pressure generated force (130 to 290 psi (9 to 20 bar)) overcomes solenoid force.

Operation of Manual Override Option: To override, push and hold the override button. The override is not detented. The manual override option is intended for emergency use, not for continuous duty operation.

Features

- Filter screen on the inlet port for protection from contamination
- Push type manual override button, protected by rubber cap

Specifications

Operating Pressure	5000 psi (350 bar)
Nominal Flow	8 gpm (30 l/min)
Internal Leakage	Leaktight, less than 5 drops/min. at 5000 psi (0.25 cc/min at 350 bar)
Fluid Operating Temp. Range	-4° to 248°F (-20° to 120°C) (Consult factory for usage at temp. outside range.)
Ambient Temperature Range	-4° to 140°F (-20° to 60°C)
Coil Duty Rating	Continuous from 85% to 115% of nominal voltage
Current Draw @ 68°F (20°C)	1.5 A at 12VDC; 0.8 A at 24VDC
Min. Pull-in Voltage @ 68°F (20°C)	85% of nominal @ 5000 psi (350 bar)
Response Time (typical)	Energized: 50ms De-Energized: 35ms
Fluid Compatibility	Mineral-Based or Synthetics with lubricating properties.
Viscosity	50 to 2000 SUS (7.4 to 420 cSt)
Filtration	21/19/16 or cleaner per (ISO 4406). Use with filter rated $\beta_{10} \geq 200$.
Filter screen	300 μ m mesh
Installation	No orientation restrictions
Cavity	FC08-2 (see <i>Line Bodies and Cavities</i> section)
Cavity Tools	Rougher: 02580090 Finisher: 02580091
Cartridge Weight	0.31 Lbs. (0.14 kg)
Coil Weight	0.42 Lbs. (0.19 kg)
Cartridge Material	Steel with hardened work surfaces. Zinc plated exposed surfaces. Buna N or Viton® o-rings. PTFE back-up rings.
Coil Material	Class N high temperature magnet wire, steel shell, polyamid encapsulation.
Seal Kits	Buna-N FS082-N P/N: 03033920 Viton® FS082-V P/N: 03051756

Performance

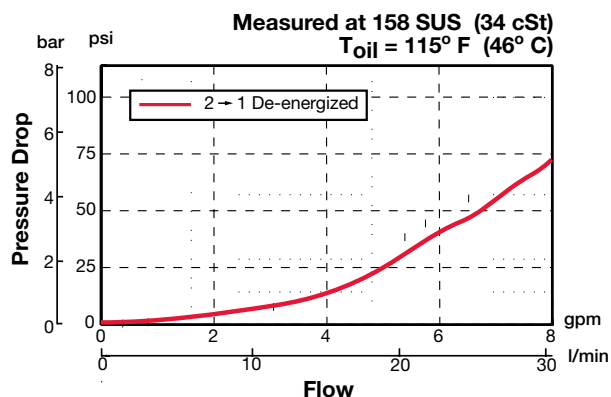

Dimensions

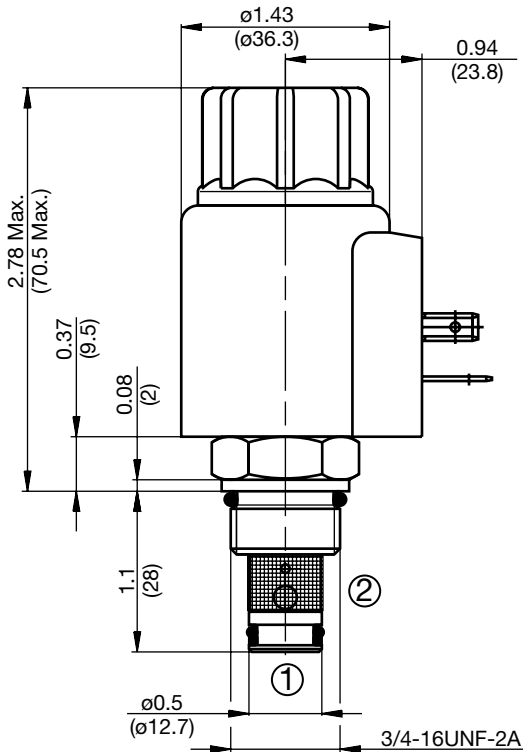
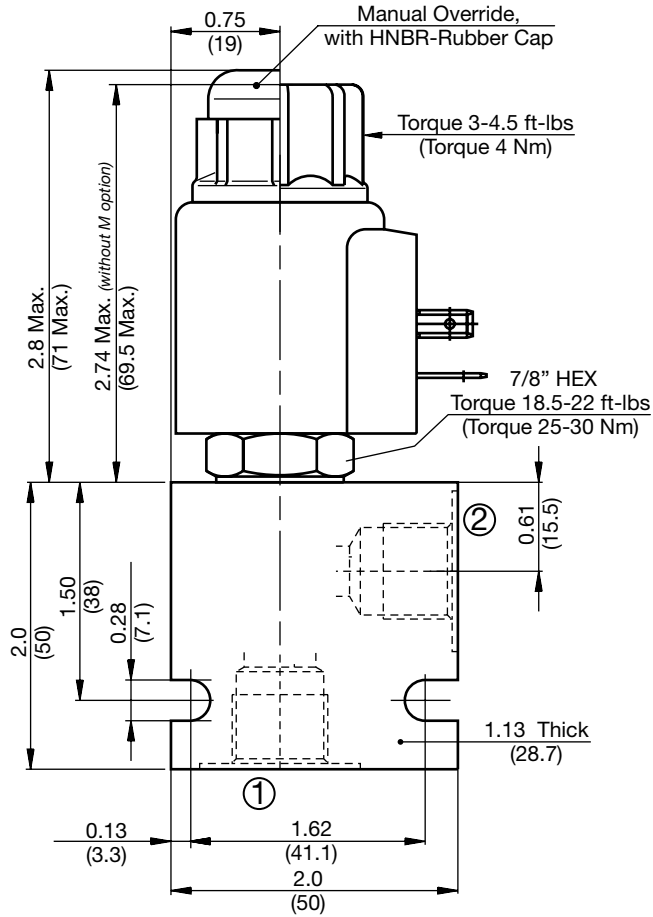

All measurements in inches (mm).
Subject to technical modifications

Model Code

WS08YR-30 M-C-N-24 DS

- Valve Model** _____
- Override Option** _____
 blank = No manual override
 M = Manual override, push type
- Body & Ports** _____
 C = Cartridge only
 AS6 = SAE-6 Ports, aluminum body
 SS6 = SAE-6 Ports, steel body
- Seals** _____
 N = Buna-N
 V = Viton®
- Coil Voltage** _____
 0 = No coil, cartridge only
- DC** _____
 12 = 12 VDC
 24 = 24 VDC
 36 = 36 VDC
 110 = 110 VDC (only available with connector DG)
- AC** _____
 24 = 24 VAC
 115 = 115 VAC (AC coils internally full wave rectified)
 230 = 230 VAC
- Coil Connector** _____
 DC DG = EN 175301-803-A
 DS = Dual spade (SAEJ858a)*
 DL = Leadwires (2) - 18" long (46 cm)*
 DW = WeatherPak™ on leadwires - 9.5" long (24 cm)*
 DN = Deutsch™ DT04-2P, molded, axial (IP69K Rated)*
 DT = Amp Junior Timer™, molded, radial mount*
- AC AG** = EN 175301-803-A

Coil Model 40-1836

For other coil connector types consult factory

*Coils with internal diode are available, consult factory.

Standard Line Bodies*

Code	Part No	Material	Pressure Rating	Weight
FH082-AS6	03011409	Aluminum, anodized	3500 psi (245 bar)	0.34 lbs (0.15 kg)
FH082-SS6	00560917	Steel, Zinc plated	6000 psi (420 bar)	1.0 lbs (0.45 kg)

*Please refer to Line Bodies & Cavities section for details

SOLENOID VALVES

WS06Z-01

Poppet Type, Normally Closed, Pilot Operated

Up to 5 gpm (19 l/min) • 5000 psi (350 bar)

Hydraulic Symbol

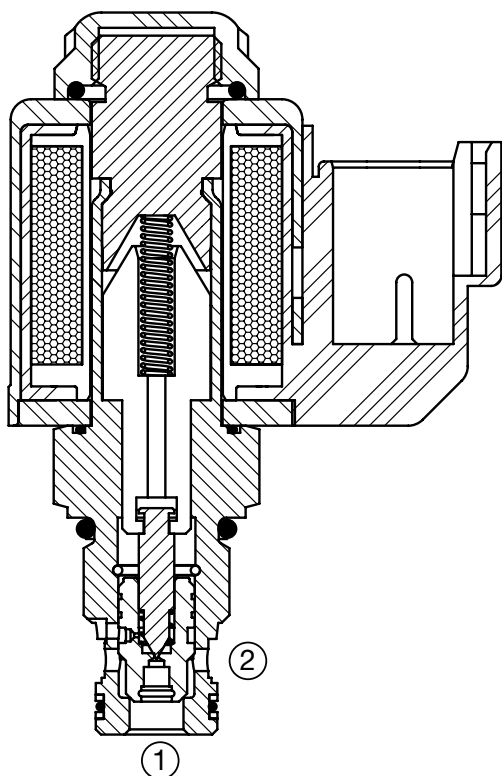
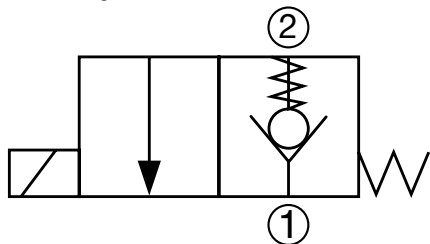

Description

A screw-in cartridge, solenoid operated, 2 way 2 position, normally closed, pilot operated, poppet type intended for use as a uni-directional blocking or load holding device in hydraulic circuits requiring low internal leakage.

Operation

When de-energized the WS06Z blocks flow from port 2 to port 1, while allowing flow from port 1 to port 2. When energized the poppet lifts and opens the flow from port 2 to port 1, while the flow from port 1 to port 2 is severely restricted.

Specifications

Operating Pressure	5000 psi (350 bar)
Nominal Flow	3.5 gpm (13.3 l/min)
Internal Leakage	Leaktight, less than 5 drops/min. at 5000 psi (350 bar)
Fluid Operating Temp Range	-20° to 248°F (-29° to 120°C)
Ambient Temperature Range	-20° to 140°F (-29° to 60°C)
Coil Duty Rating	Continuous from 85% to 115% of nominal voltage
Current Draw at 68°F (20°C)	984 mA at 12VDC; 492 mA at 24VDC
Minimum Pull-in Current to Operate Valve	70% of nominal amperage
Typical Response Time (Varies with Pressure and Flow)	Energized: 35ms De-Energized: 50ms
Fluid Compatibility	Mineral-Based or Synthetics with lubricating properties.
Viscosity	50 to 2000 SUS (7.4 to 420 cSt)
Filtration	21/19/16 or cleaner per (ISO 4406)
Installation	No orientation restrictions
Cavity	FC06-2 (see Line Bodies & Cavities section)
Cavity Tools	Rougher: 02582046 Finisher: 02582047
Cartridge Weight	2.7 oz (75 grams)
Coil Weight	3.1 oz (88 grams)
Cartridge Material	Steel with hardened work surfaces. Zinc plated exposed surfaces. Buna N or Viton® o-rings. Solid thermoplastic polyester back-up rings.
Coil Material	Class N, 200°C high temperature magnet wire. steel shell, polyester encapsulation.
Seal Kits	Buna-N FS062-N P/N: 02610184 Viton® FS062-V P/N: 02610185

Performance

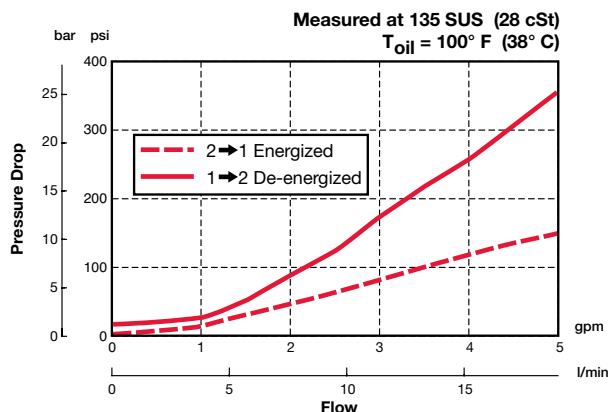

Dimensions

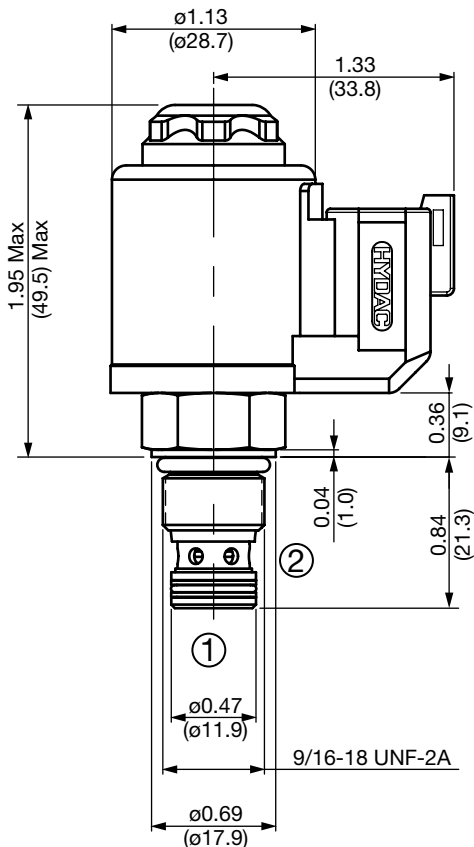
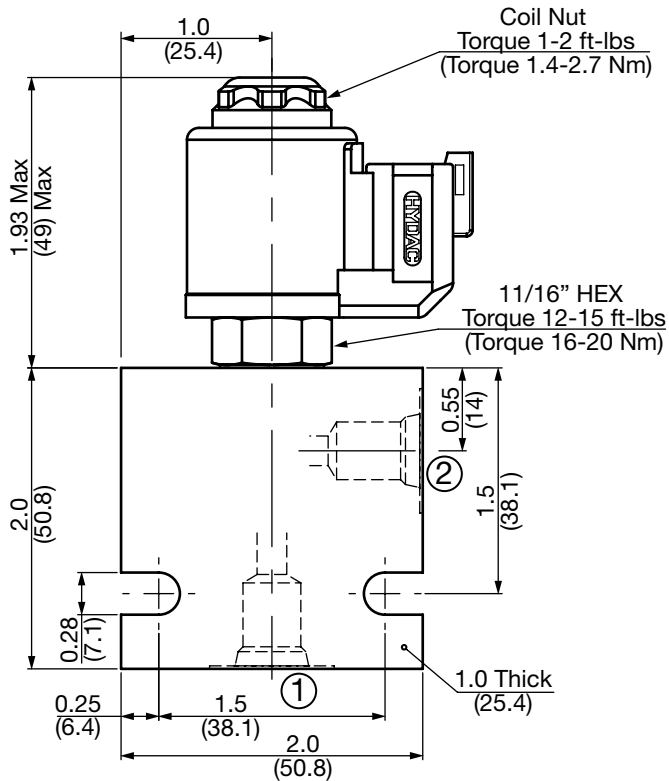

All measurements in inches (mm).
Subject to technical modifications

PN#02087369 / 10.19 / CHD1110-1389

Model Code

WS06Z-01 M-C-N-24 DN

Valve Model _____

Override Option _____
blank = No manual override
M = Manual override, screw type

Body & Ports _____
C = Cartridge only
AS4 = SAE-4 Ports, aluminum body
SS4 = SAE-4 Ports, steel body

Seals _____
N = Buna-N
V = Viton®

Coil Voltage _____
0 = No coil, cartridge only
DC 12 = 12 VDC
24 = 24 VDC
AC 115 = 105 VDC (only available with connector DG)
230 = 205 VDC (only available with connector DG)
(All model 32-1329 coils are DC. AC models require an external diode bridge mounted outside the coil)**

Coil Connector _____
DG = EN 175301-803-B (IP65 Rated)**
DL = Leadwires (2) - 18" long (46 cm) AWG18, TYPE UL 1815 (IP69K Rated)*
DN = Deutsch DT04-2P intergral molded (IP69K Rated)*
Use mating plug EN 175301-803-B without diode bridge for DC voltages P/N 02600570
Use mating plug EN 175301-803-B w/diode bridge for AC voltages P/N 02600582

Coil Model 32-1329
For other coil connector types consult factory

** Mating Plugs sold separately
*Coils with internal transient suppression diode are available, consult factory.

Standard Line Bodies*

Code	Part No	Material	Pressure Rating	Weight
FH062-AS4	02600491	Aluminum, anodized	3500 psi (245 bar)	0.33 lbs (0.15 kg)
FH062-SS4	02600490	Steel, Zinc plated	6000 psi (420 bar)	0.97 lbs (0.44 kg)

*Please refer to Line Bodies & Cavities section for details

SOLENOID VALVES

WS08Z-01

Poppet Type, Normally Closed, Pilot Operated

Up to 10 gpm (38 l/min) • 5000 psi (350 bar)

Hydraulic Symbol

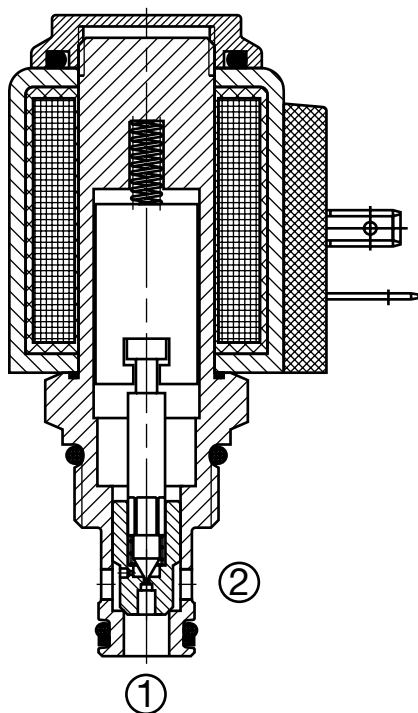
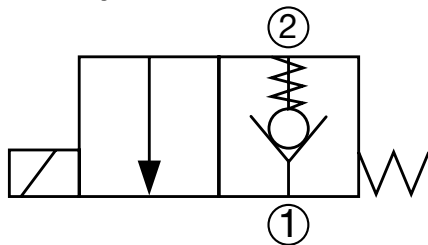

Description

A screw-in cartridge, solenoid operated, 2-way, 2 position, normally closed, pilot operated, poppet type intended for use as a uni-directional blocking or load holding device in hydraulic circuits requiring low internal leakage.

Operation

When de-energized the WS08Z blocks flow from port 2 to port 1, while allowing flow from port 1 to port 2. When energized the poppet lifts and opens the flow from port 2 to port 1, while the flow from port 1 to port 2 is severely restricted. If this flow path is required see model WS08ZR.

Operation of Manual Override Option: To override, remove the coil nut, turn the override knurled knob counterclockwise until it stops. The override will remain activated until the knob is turned clockwise to original position. The manual override option is intended for emergency use, not for continuous duty operation.

Features

- Screw type manual override option

Specifications

Operating Pressure	5000 psi (350 bar)
Nominal Flow	10 gpm (38 l/min)
Internal Leakage	Leaktight, less than 5 drops/min. at 5000 psi (0.25 cc/min at 350 bar)
Fluid Operating Temp. Range	-4° to 248°F (-20° to 120°C) (Consult factory for usage at temp. outside range.)
Ambient Temperature Range	-4° to 140°F (-20° to 60°C)
Coil Duty Rating	Continuous from 85% to 115% of nominal voltage
Current Draw @ 68°F (20°C)	1.5 A at 12VDC; 0.8 A at 24VDC
Min. Pull-in Voltage @ 68°F (20°C)	85% of nominal @ 5000 psi (350 bar)
Response Time (typical)	Energized 35 ms De-energized 50 ms
Fluid Compatibility	Mineral-based or synthetics with lubricating properties
Viscosity	50 to 2000 SUS (7.4 to 420 cSt)
Filtration	21/19/16 or cleaner (per ISO 4406). Use with filter rated $\beta_{10} \geq 200$.
Installation	No orientation restrictions
Cavity	FC08-2 (see <i>Line Bodies & Cavities</i> section)
Cavity Tools	Rougher: 02580090 Finisher: 02580091
Cartridge Weight	0.31 Lbs. (0.14 kg)
Coil Weight	0.42 Lbs. (0.19 kg)
Cartridge Material	Steel with hardened work surfaces. Zinc-plated exposed surfaces. Buna N or Viton® o-rings. PTFE back-up rings.
Coil Material	Class N high temperature magnet wire, steel shell, polyamid encapsulation.
Seal Kits	Buna-N P/N: 03033920 Viton® P/N: 03051756

Performance

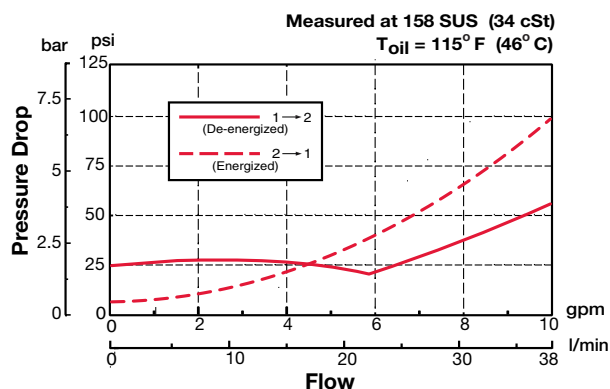

Dimensions

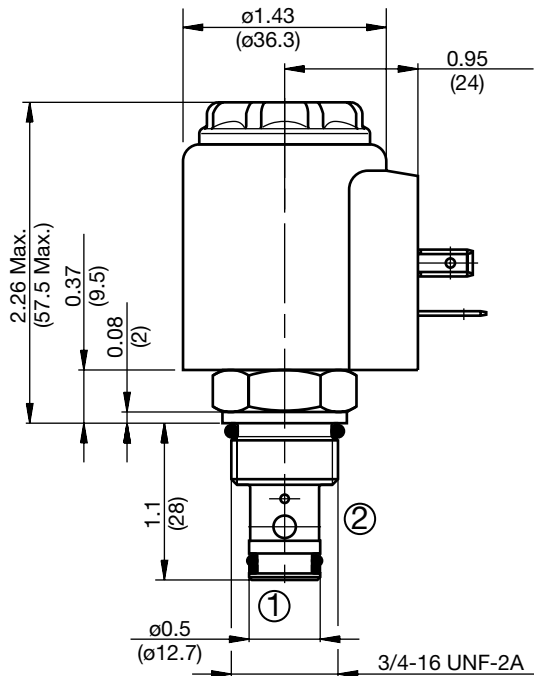
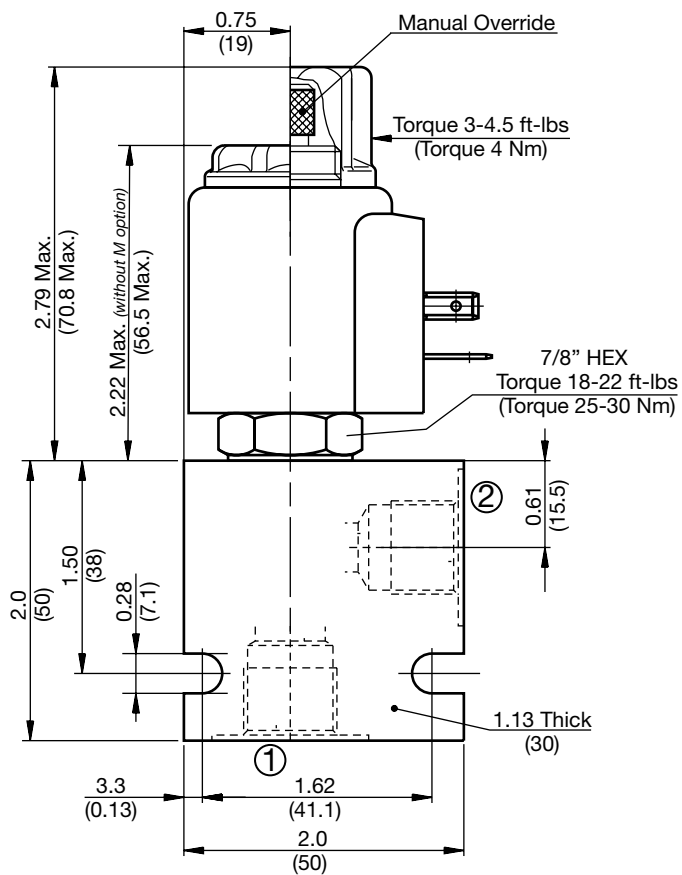

Model Code

WS08Z-01 M-C-N-24 DS

- Valve Model** _____
- Override Option** _____
blank = No manual override
M = Manual override, screw type
- Body & Ports** _____
C = Cartridge only
AS6 = SAE-6 Ports, aluminum body
SS6 = SAE-6 Ports, steel body
- Seals** _____
N = Buna-N
V = Viton®
- Coil Voltage** _____
0 = No coil, cartridge only
- DC** _____
12 = 12 VDC
24 = 24 VDC
36 = 36 VDC
110 = 110 VDC (only available with connector DG)
- AC** _____
24 = 24 VAC
115 = 115 VAC (AC coils internally full wave rectified)
230 = 230 VAC
- Coil Connector** _____
DC DG = EN 175301-803-A
DS = Dual spade (SAEJ858a)*
DL = Leadwires (2) - 18" long (46 cm)*
DW = WeatherPak™ on leadwires - 9.5" long (24 cm)*
DN = Deutsch™ DT04-2P, molded, axial (IP69K Rated)*
DT = Amp Junior Timer™, molded, radial mount*
- AC AG = EN 175301-803-A

Coil Model 40-1836

For other coil connector types consult factory

*Coils with internal diode are available, consult factory.

All measurements in inches (mm).
Subject to technical modifications

PN#02087369 / 10.19 / CHD1110-1389

Standard Line Bodies*

Code	Part No	Material	Pressure Rating	Weight
FH082-AS6	03011409	Aluminum, anodized	3500 psi (245 bar)	0.34 lbs (0.15 kg)
FH082-SS6	00560917	Steel, Zinc plated	6000 psi (420 bar)	1.0 lbs (0.45 kg)

*Please refer to Line Bodies & Cavities section for details

SOLENOID VALVES

WS10Z-01

Poppet Type, Normally Closed, Pilot Operated

20 gpm (75 l/min) • 5000 psi (350 bar)

Hydraulic Symbol

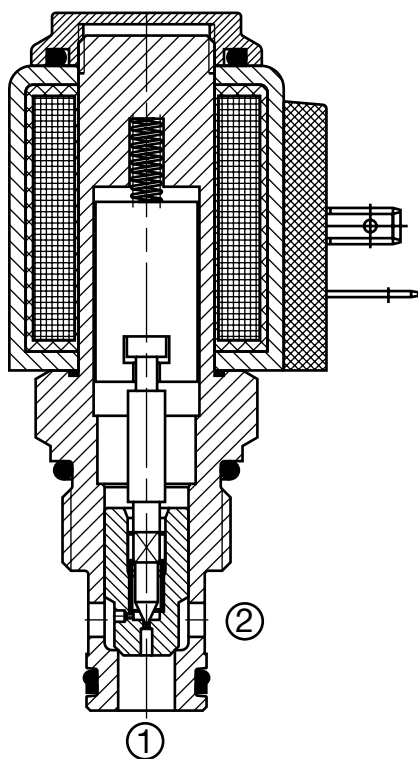
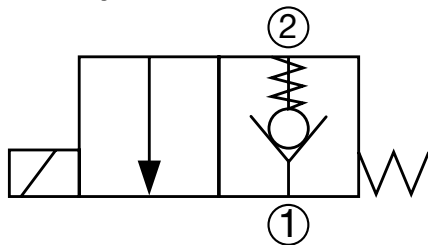

Description

A screw-in cartridge, solenoid operated, 2-way, 2 position, normally closed, pilot operated, poppet type intended for use as a uni-directional blocking or load holding device in hydraulic circuits requiring low internal leakage.

Operation

When de-energized the WS10Z blocks flow from port 2 to port 1, while allowing flow from port 1 to port 2. When energized the poppet lifts and opens the flow from port 2 to port 1, while the flow from port 1 to port 2 is severely restricted. If this flow path is required see model WS10ZR.

Operation of Manual Override Option: To override, remove the coil nut, turn the override knurled knob counterclockwise until it stops. The override will remain activated until the knob is turned clockwise to original position. The manual override option is intended for emergency use, not for continuous duty operation.

Features

- Screw type manual override option

Specifications

Operating Pressure	5000 psi (350 bar)
Nominal Flow	20 gpm (75 l/min)
Internal Leakage	Leaktight, less than 5 drops/min. at 5000 psi (0.25 cc/min at 350 bar)
Fluid Operating Temp. Range	-4° to 248°F (-20° to 120°C) (Consult factory for usage at temp. outside range.)
Ambient Temperature Range	-4° to 140°F (-20° to 60°C)
Coil Duty Rating	Continuous from 85% to 115% of nominal voltage
Current Draw @ 68°F (20°C)	1.5 A at 12VDC; 0.8 A at 24VDC
Min. Pull-in Voltage @ 68°F (20°C)	85% of nominal @ 5000 psi (350 bar)
Response Time (typical)	Energized 30 ms De-energized 60 ms
Fluid Compatibility	Mineral-based or synthetics with lubricating properties
Viscosity	50 to 2000 SUS (7.4 to 420 cSt)
Filtration	21/19/16 or cleaner (per ISO 4406). Use with filter rated $\beta_{10} \geq 200$.
Installation	No orientation restrictions
Cavity	FC10-2 (see Line Bodies & Cavities section)
Cavity Tools	Rougher: 02580274 Finisher: 02580247
Cartridge Weight	0.40 Lbs. (0.182 kg)
Coil Weight	0.42 Lbs. (0.190 kg)
Cartridge Material	Steel with hardened work surfaces. Zinc-plated exposed surfaces. Buna N or Viton® o-rings. PTFE back-up rings.
Coil Material	Class N high temperature magnet wire, steel shell, polyamid encapsulation.
Seal Kits	Buna-N P/N: 03033872 Viton® P/N: 03051757

Performance

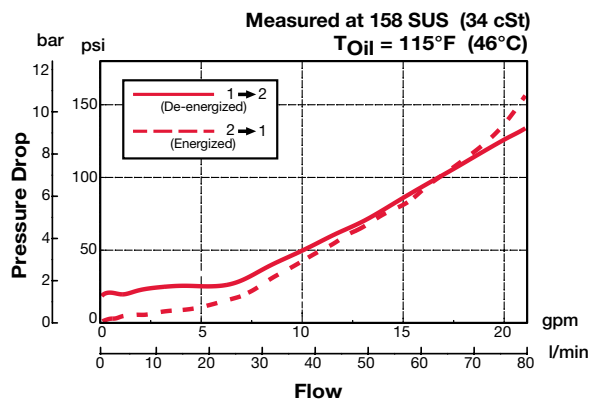

SOLENOID VALVES

WS12Z-01

Poppet Type, Normally Closed, Pilot Operated

Up to 29 gpm (110 l/min) • 5000 psi (350 bar)

Hydraulic Symbol

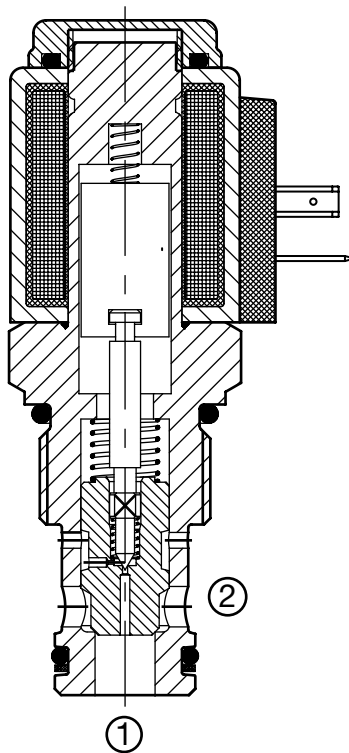
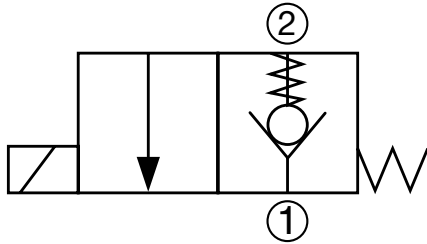

Description

A screw-in cartridge, solenoid operated, 2-way, 2 position, normally closed, pilot operated, poppet type intended for use as a uni-directional blocking or load holding device in hydraulic circuits requiring low internal leakage.

Operation

When de-energized the WS12Z blocks flow from port 2 to port 1, while allowing flow from port 1 to port 2. When energized the poppet lifts and opens the flow from port 2 to port 1, while the flow from port 1 to port 2 is severely restricted.

Operation of Manual Override Option: To override, remove the coil nut, turn the override knurled knob counterclockwise until it stops. The override will remain activated until the knob is turned clockwise to original position. The manual override option is intended for emergency use, not for continuous duty operation.

Features

- Screw type manual override option

Specifications

Operating Pressure	5000 psi (350 bar)		
Nominal Flow	29 gpm (110 l/min)		
Internal Leakage	Leaktight, less than 5 drops/min. at 5000 psi (0.25 cc/min at 350 bar)		
Fluid Operating Temp. Range	-4° to 248°F (-20° to 120°C) <i>(Consult factory for usage at temp. outside range.)</i>		
Ambient Temperature Range	-4° to 140°F (-20° to 60°C)		
Coil Duty Rating	Continuous from 85% to 115% of nominal voltage		
Current Draw @ 68°F (20°C)	1.5 A at 12VDC; 0.8 A at 24VDC		
Min. Pull-in Voltage @ 68°F (20°C)	85% of nominal @ 5000 psi (350 bar)		
Response Time (typical)	Energized	30 ms	
	De-energized	70 ms	
Fluid Compatibility	Mineral-based or synthetics with lubricating properties		
Viscosity	50 to 2000 SUS (7.4 to 420 cSt)		
Filtration	21/19/16 or cleaner (per ISO 4406). Use with filter rated $\beta_{10} \geq 200$.		
Installation	No orientation restrictions		
Cavity	FC12-2 (see <i>Line Bodies & Cavities</i> section)		
Cavity Tools	Rougher:	02580667	
	Finisher:	02580668	
Cartridge Weight	0.60 Lbs. (0.27 kg)		
Coil Weight	0.42 Lbs. (0.19 kg)		
Cartridge Material	Steel with hardened work surfaces. Zinc-plated exposed surfaces. Buna N or Viton® o-rings. PTFE back-up rings.		
Coil Material	Class N high temperature magnet wire, steel shell, polyamid encapsulation.		
Seal Kits	Buna-N	FS122-N	P/N: 03071298
	Viton®	FS122-V	P/N: 03071299

Performance

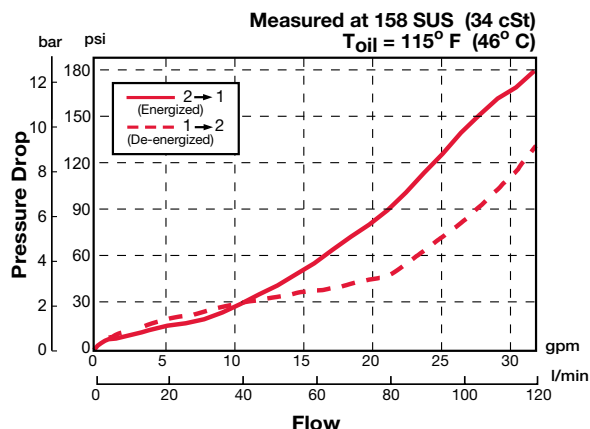

Dimensions

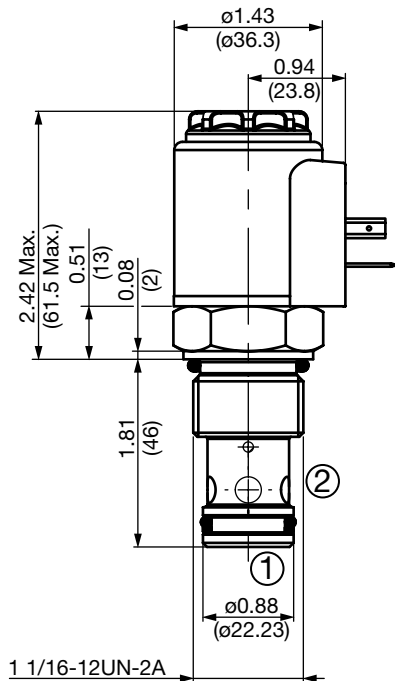
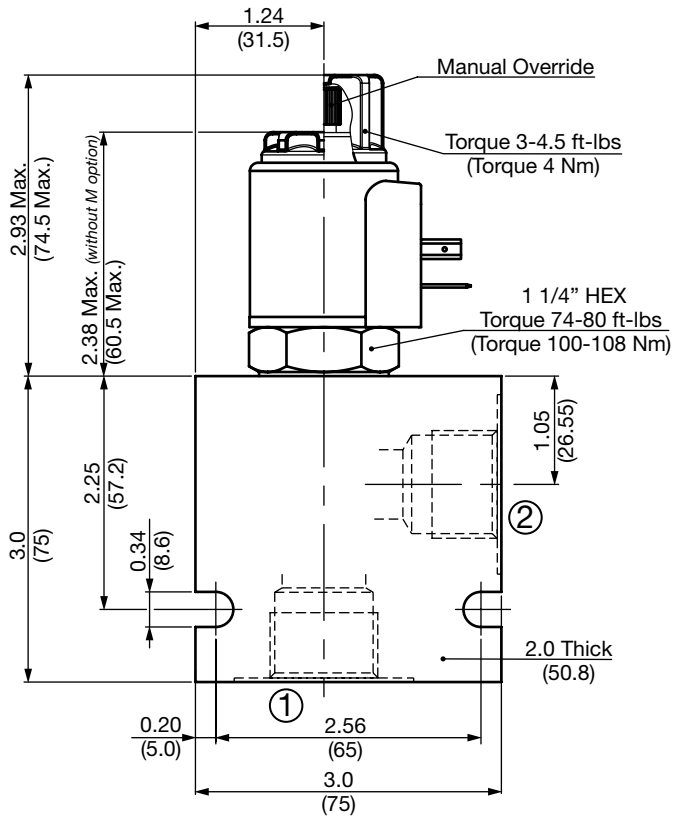

Model Code

WS12Z-01 M-C-N-24 DN

- Valve Model** _____
- Override Option** _____
 blank = No manual override
 M = Manual override, screw type
- Body & Ports** _____
 C = Cartridge only
 AS12 = SAE-12 Ports, aluminum body
 SS12 = SAE-12 Ports, steel body
- Seals** _____
 N = Buna-N
 V = Viton®
- Coil Voltage** _____
 0 = No coil, cartridge only
 DC 12 = 12 VDC
 24 = 24 VDC
 36 = 36 VDC
 110 = 110 VDC (only available with connector DG)
 AC 24 = 24 VAC
 115 = 115 VAC (AC coils internally full wave rectified)
 230 = 230 VAC
- Coil connector** _____
 DC DG = EN 175301-803-A
 DS = Dual spade (SAEJ858a)*
 DL = Leadwires (2) - 18" long (46 cm)*
 DW = WeatherPak™ on leadwires - 9.5" long (24 cm)*
 DN = Deutsch™ DT04-2P, molded, axial (IP69K Rated)*
 DT = Amp Junior Timer™, molded, radial mount*
- AC AG = EN 175301-803-A

Coil Model 40-1836

For other coil connector types consult factory

*Coils with internal diode are available, consult factory.

All measurements in inches (mm).
 Subject to technical modifications

PN#02087369 / 10.19 / CHD1110-1389

Standard Line Bodies*

Code	Part No	Material	Pressure Rating	Weight
FH122-AS12	03053845	Aluminum, anodized	3500 psi (245 bar)	1.39 lbs (0.63 kg)
FH122-SS12	03053772	Steel, Zinc plated	6000 psi (420 bar)	4.16 lbs (1.89 kg)

*Please refer to Line Bodies & Cavities section for details

SOLENOID VALVES

WS16Z-01

Poppet Type, Normally Closed, Pilot Operated

Up to 40 gpm (150 l/min) • 5000 psi (350 bar)

Hydraulic Symbol

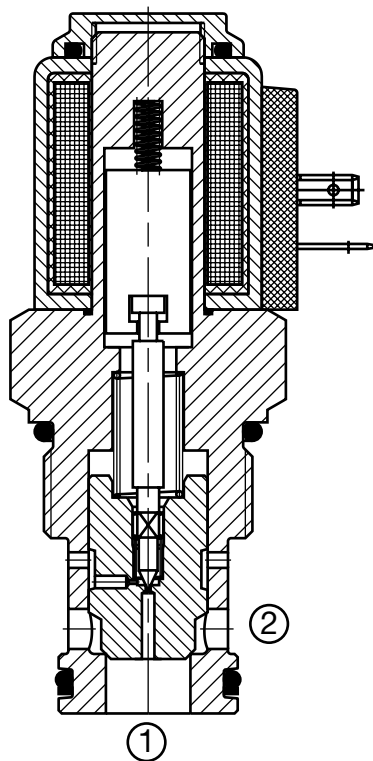
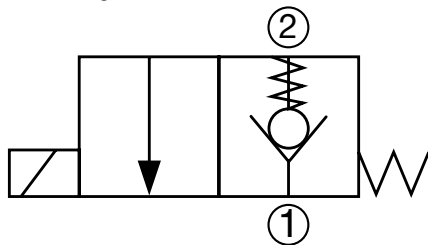

Description

A screw-in cartridge, solenoid operated, 2-way, 2 position, normally closed, pilot operated, poppet type intended for use as a uni-directional blocking or load holding device in hydraulic circuits requiring low internal leakage.

Operation

When de-energized the WS16Z blocks flow from port 2 to port 1, while allowing flow from port 1 to port 2. When energized the poppet lifts and opens the flow from port 2 to port 1, while the flow from port 1 to port 2 is severely restricted. If this flow path is required see model WS16ZR.

Operation of Manual Override Option: To override, remove the coil nut, turn the override knurled knob counterclockwise until it stops. The override will remain activated until the knob is turned clockwise to original position. The manual override option is intended for emergency use, not for continuous duty operation.

Features

- Screw type manual override option

Specifications

Operating Pressure	5000 psi (350 bar)	
Nominal Flow	40 gpm at 4060 psi (150 l/min at 280 bar) 26 gpm at 5000 psi (100 l/min at 350 bar)	
Internal Leakage	Leaktight, less than 5 drops/min. at 5000 psi (0.25 cc/min at 350 bar)	
Fluid Operating Temp. Range	-4° to 248°F (-20° to 120°C) <i>(Consult factory for usage at temp. outside range.)</i>	
Ambient Temperature Range	-4° to 140°F (-20° to 60°C)	
Coil Duty Rating	Continuous from 85% to 115% of nominal voltage	
Current Draw @ 68°F (20°C)	1.5 A at 12VDC; 0.8 A at 24VDC	
Min. Pull-in Voltage @ 68°F (20°C)	85% of nominal @ 5000 psi (350 bar)	
Response Time (typical)	Energized	30 ms
	De-energized	70 ms
Fluid Compatibility	Mineral-based or synthetics with lubricating properties	
Viscosity	50 to 2000 SUS (7.4 to 420 cSt)	
Filtration	21/19/16 or cleaner (per ISO 4406). Use with filter rated $\beta_{10} \geq 200$.	
Installation	No orientation restrictions	
Cavity	FC16-2 (see <i>Line Bodies & Cavities</i> section)	
Cavity Tools	Rougher:	02580250
	Finisher:	02580251
Cartridge Weight	1.37 Lbs. (0.62 kg)	
Coil Weight	0.42 Lbs. (0.19 kg)	
Cartridge Material	Steel with hardened work surfaces. Zinc-plated exposed surfaces. Buna N or Viton® o-rings. PTFE back-up rings.	
Coil Material	Class N high temperature magnet wire, steel shell, polyamid encapsulation.	
Seal Kits	Buna-N	FS162-N P/N: 03052427
	Viton®	FS162-V P/N: 03051758

Performance

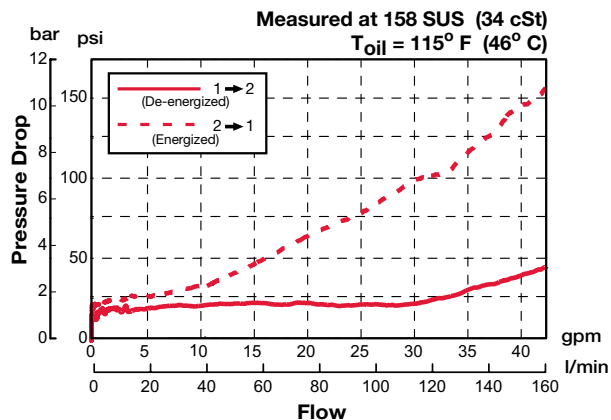

Dimensions

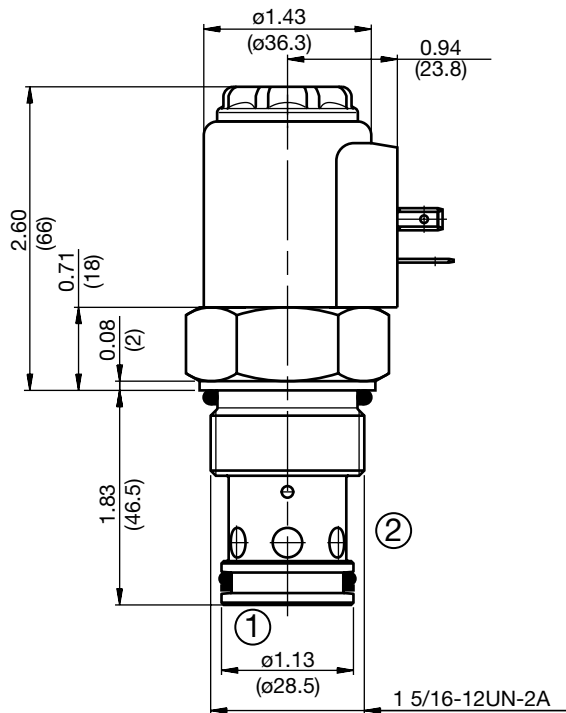
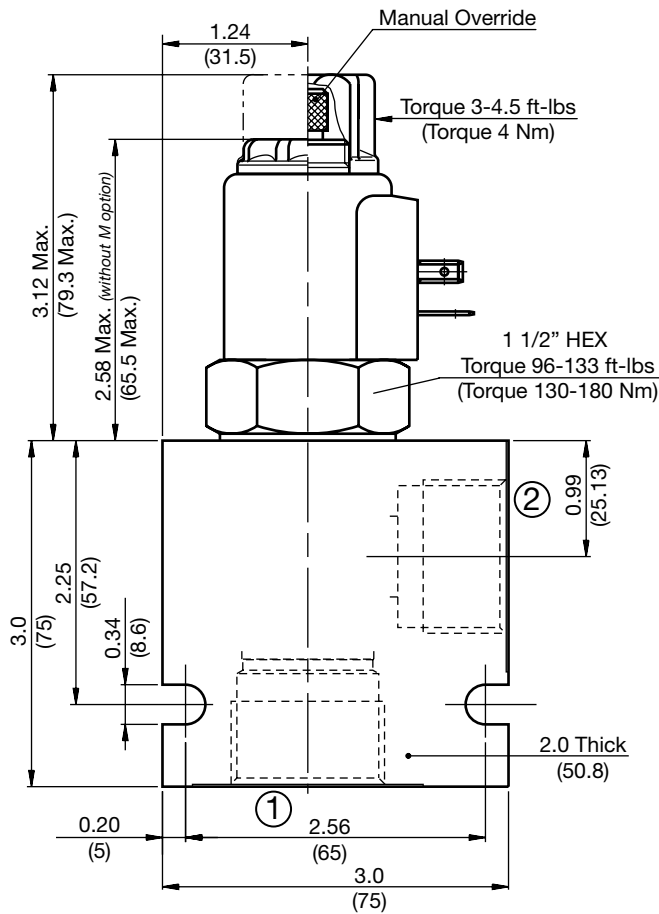

All measurements in inches (mm).
Subject to technical modifications

Model Code

WS16Z-01 M-C-N-24 DN

Valve Model

Override Option

blank = No manual override
M = Manual override, screw type

Body & Ports

C = Cartridge only
AS16 = SAE-16 Ports, aluminum body
SS16 = SAE-16 Ports, steel body

Seals

N = Buna-N
V = Viton®

Coil Voltage

0 = No coil, cartridge only

DC

12 = 12 VDC
24 = 24 VDC
36 = 36 VDC
110 = 110 VDC (only available with connector DG)

AC

24 = 24 VAC
115 = 115 VAC (AC coils internally full wave rectified)
230 = 230 VAC

Coil Connector

DC DG = EN 175301-803-A
DS = Dual spade (SAEJ858a)*
DL = Leadwires (2) - 18" long (46 cm)*
DW = WeatherPak™ on leadwires - 9.5" long (24 cm)*
DN = Deutsch™ DT04-2P, molded, axial (IP69K Rated)*
DT = Amp Junior Timer™, molded, radial mount*

AC AG = EN 175301-803-A

Coil Model 40-1836

For other coil connector types consult factory

*Coils with internal diode are available, consult factory.

Standard Line Bodies*

Code	Part No	Material	Pressure Rating	Weight
FH162-AS16	03037195	Aluminum, anodized	3500 psi (245 bar)	1.2 lbs (0.55 kg)
FH162-SS16	03032655	Steel, Zinc plated	6000 psi (420 bar)	3.56 lbs (1.62 kg)

*Please refer to Line Bodies & Cavities section for details

SOLENOID VALVES

WS08Z-01J

Poppet Type, Normally Closed, Pilot Operated

Up to 10 gpm (38 l/min) • 5000 psi (350 bar)

Hydraulic Symbol

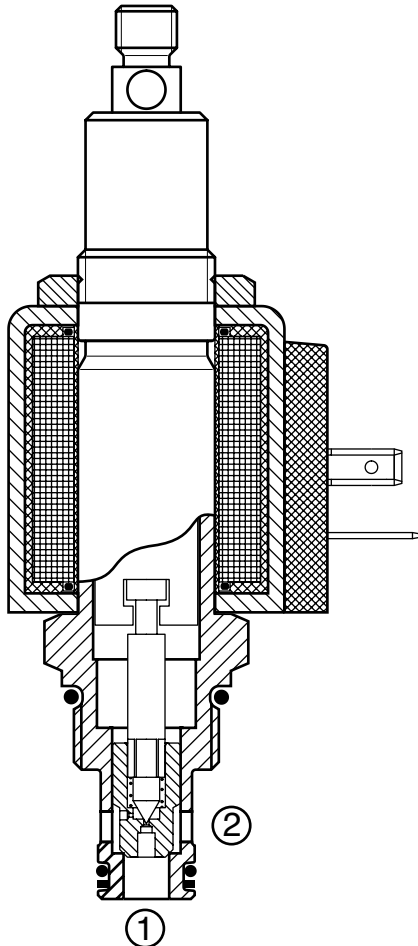
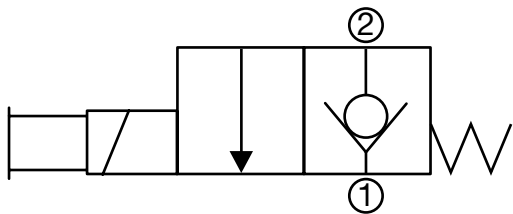

Description

A screw-in cartridge, solenoid operated, 2-way, 2 position, normally closed, pilot operated, poppet type with pull type, spring return manual override, intended for use as a uni-directional blocking or load holding device in hydraulic circuits requiring low internal leakage.

Operation

When de-energized the WS08Z-01J blocks flow from port 2 to port 1, while allowing flow from port 1 to port 2. When energized the poppet lifts and opens the flow from port 2 to port 1, while the flow from port 1 to port 2 is severely restricted. If this flow path is required see model WS08ZR-01J.

Operation of Manual Override Option: To manually override pull and hold the override stem. This override is not detented. The override stem has a male thread M8X1.25 and hole for a cable attachment. If a cable is used, the internal spring may not provide enough force to overcome internal cable friction. An external means of returning the cable must be provided by the user. The manual override option is intended for emergency use, not for continuous duty operation.

Features

- Rugged manual override design with thread and hole for a handle or cable attachment

Specifications

Operating Pressure	5000 psi (350 bar)
Nominal Flow	10 gpm (38 l/min)
Internal Leakage	Leaktight, less than 5 drops/min. at 5000 psi (0.25 cc/min at 350 bar)
Manual Override Pull Force	38 - 40.5 bs (150 - 180 N) Max. permissible pull force
Fluid Operating Temp. Range	-4° to 248°F (-20° to 120°C) (Consult factory for usage at temp. outside range.)
Ambient Temperature Range	-4° to 140°F (-20° to 60°C)
Coil Duty Rating	Continuous from 85% to 115% of nominal voltage
Current Draw @ 68°F (20°C)	1.5 A at 12VDC; 0.8 A at 24VDC
Min. Pull-in Voltage @ 68°F (20°C)	85% of nominal @ 5000 psi (350 bar)
Response Time (typical)	Energized 35 ms De-energized 50 ms
Fluid Compatibility	Mineral-based or synthetics with lubricating properties
Viscosity	50 to 2000 SUS (7.4 to 420 cSt)
Filtration	21/19/16 or cleaner (per ISO 4406). Use with filter rated $\beta_{10} \geq 200$.
Installation	No orientation restrictions
Cavity	FC08-2 (see Line Bodies & Cavities section)
Cavity Tools	Rougher: 02580090 Finisher: 02580091
Cartridge Weight	0.31 Lbs. (0.14 kg)
Coil Weight	0.42 Lbs. (0.19 kg)
Cartridge Material	Steel with hardened work surfaces. Zinc-plated exposed surfaces. Buna N or Viton® o-rings. PTFE back-up rings.
Coil Material	Class N high temperature magnet wire, steel shell, polyamid encapsulation.
Seal Kits	Buna-N FS082-N P/N: 03033920 Viton® FS082-V P/N: 03051756

Performance

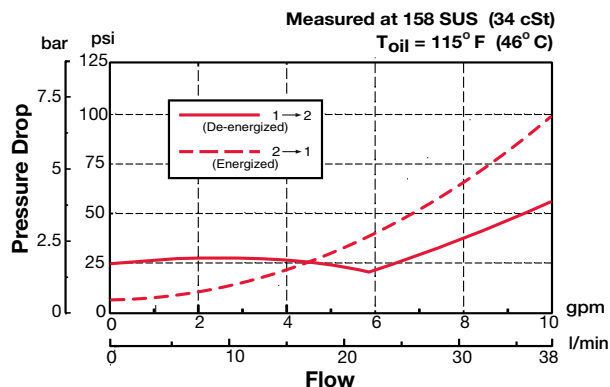

Dimensions

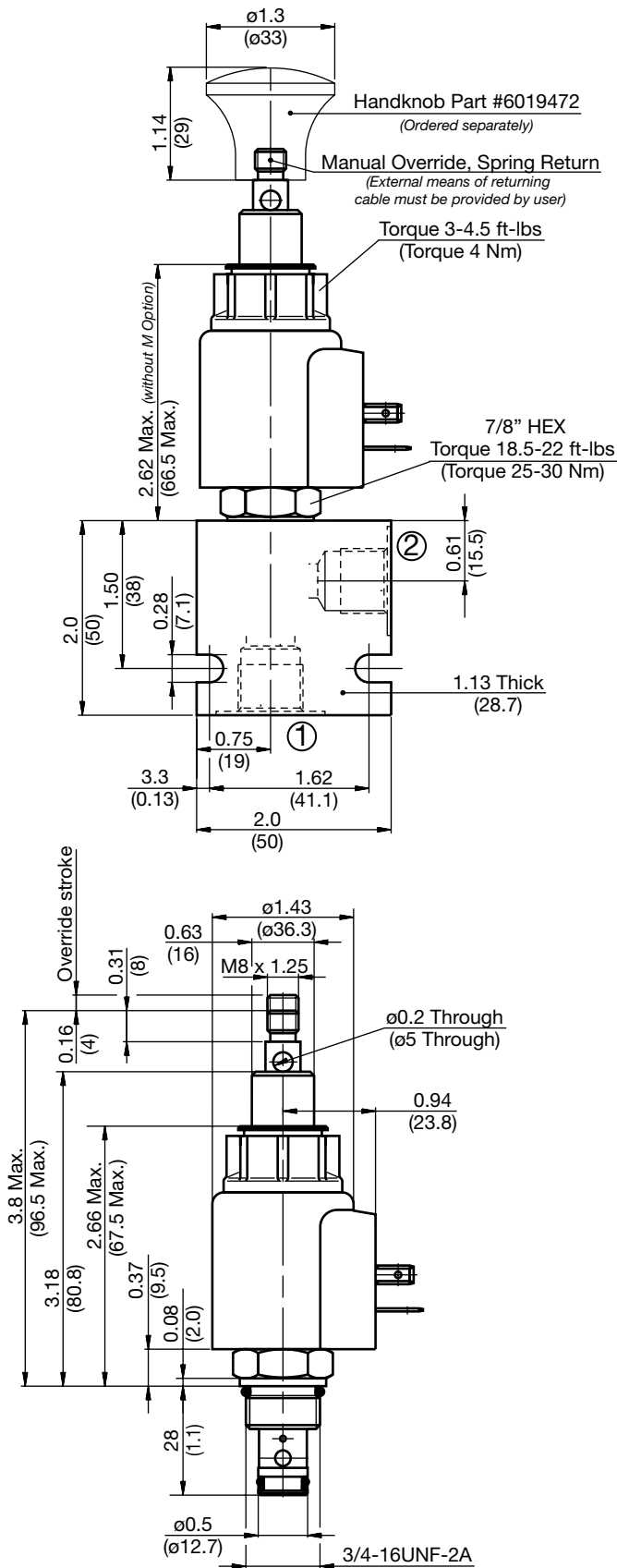

All measurements in inches (mm).
Subject to technical modifications

Model Code

WS08Z-01 J-C-N-24 DS

- Valve Model** _____
- Override Option** _____
- J = Manual override, pull type, spring return
- Body & Ports** _____
- C = Cartridge only
 - AS6 = SAE-6 Ports, aluminum body
 - SS6 = SAE-6 Ports, steel body
- Seals** _____
- N = Buna-N
 - V = Viton®
- Coil Voltage** _____
- 0 = No coil, cartridge only
- DC** _____
- 12 = 12 VDC
 - 24 = 24 VDC
 - 36 = 36 VDC
 - 110 = 110 VDC (only available with connector DG)
- AC** _____
- 24 = 24 VAC
 - 115 = 115 VAC (AC coils internally full wave rectified)
 - 230 = 230 VAC
- Coil Connector** _____
- DC DG = EN 175301-803-A
 - DS = Dual spade (SAEJ858a)*
 - DL = Leadwires (2) - 18" long (46 cm)*
 - DW = WeatherPak™ on leadwires - 9.5" long (24 cm)*
 - DN = Deutsch™ DT04-2P, molded, axial (IP69K Rated)*
 - DT = Amp Junior Timer™, molded, radial mount*
- AC AG** = EN 175301-803-A

Coil Model 40-1836

For other coil connector types consult factory

*Coils with internal diode are available, consult factory.

Standard Line Bodies*

Code	Part No	Material	Pressure Rating	Weight
FH082-AS6	03011409	Aluminum, anodized	3500 psi (245 bar)	0.34 lbs (0.15 kg)
FH082-SS6	00560917	Steel, Zinc plated	6000 psi (420 bar)	1.0 lbs (0.45 kg)

*Please refer to Line Bodies & Cavities section for details

SOLENOID VALVES

WS08Z-30

Poppet Type, Normally Closed, Pilot Operated

Up to 8 gpm (30 l/min) • 5000 psi (350 bar)

Hydraulic Symbol

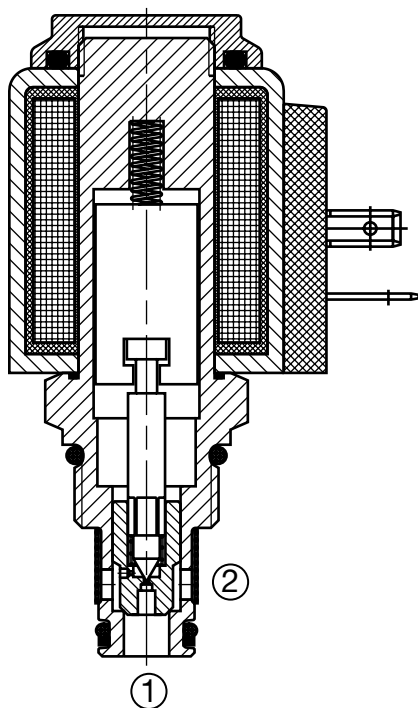
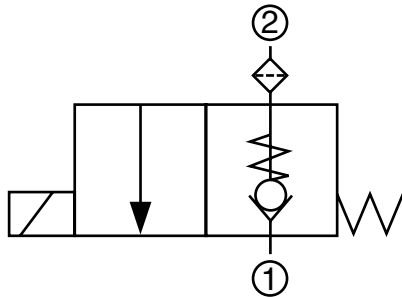

Description

A screw-in cartridge, solenoid operated, 2-way, 2 position, normally closed, pilot operated, poppet type, with a filter screen on the inlet port, intended for use as a uni-directional blocking or load holding device in hydraulic circuits requiring low internal leakage.

Operation

When de-energized the WS08Z-30 blocks flow from port 2 to port 1, while allowing flow from port 1 to port 2. When energized the poppet lifts and opens the flow from port 2 to port 1, while the flow from port 1 to port 2 is severely restricted. If this flow path is required see model WS08ZR.

Operation of Manual Override Option: To override, remove the coil nut, turn the override knurled knob counterclockwise until it stops. The override will remain activated until the knob is turned clockwise to original position. The manual override option is intended for emergency use, not for continuous duty operation.

Features

- Filter screen on the inlet port for protection from contamination
- Screw type manual override option

Specifications

Operating Pressure	5000 psi (350 bar)
Nominal Flow	8 gpm (30 l/min)
Internal Leakage	Leaktight, less than 5 drops/min. at 5000 psi (0.25 cc/min at 350 bar)
Fluid Operating Temp. Range	-4° to 248°F (-20° to 120°C) (Consult factory for usage at temp. outside range.)
Ambient Temperature Range	-4° to 140°F (-20° to +60°C)
Coil Duty Rating	Continuous from 85% to 115% of nominal voltage
Current Draw @ 68°F (20°C)	1.5 A at 12VDC; 0.8 A at 24VDC
Min. Pull-in Voltage @ 68°F (20°C)	85% of nominal @ 5000 psi (350 bar)
Response Time (typical)	Energized 35 ms De-energized 50 ms
Fluid Compatibility	Mineral-based or synthetics with lubricating properties
Viscosity	50 to 2000 SUS (7.4 to 420 cSt)
Filtration	21/19/16 or cleaner (per ISO 4406). Use with filter rated $\beta_{10} \geq 200$.
Filter screen	300 μ m mesh
Installation	No orientation restrictions
Cavity	FC08-2 (see <i>Line Bodies & Cavities</i> section)
Cavity Tools	Rougher: 02580090 Finisher: 02580091
Cartridge Weight	0.31 Lbs. (0.14 kg)
Coil Weight	0.42 Lbs. (0.19 kg)
Cartridge Material	Steel with hardened work surfaces. Zinc-plated exposed surfaces. Buna N or Viton® o-rings. PTFE back-up rings.
Coil Material	Class N high temperature magnet wire, steel shell, polyamid encapsulation.
Seal Kits	Buna-N FS082-N P/N: 03033920 Viton® FS082-V P/N: 03051756

Performance

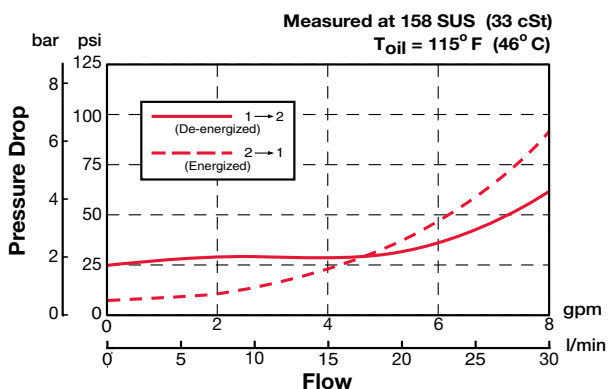

Dimensions

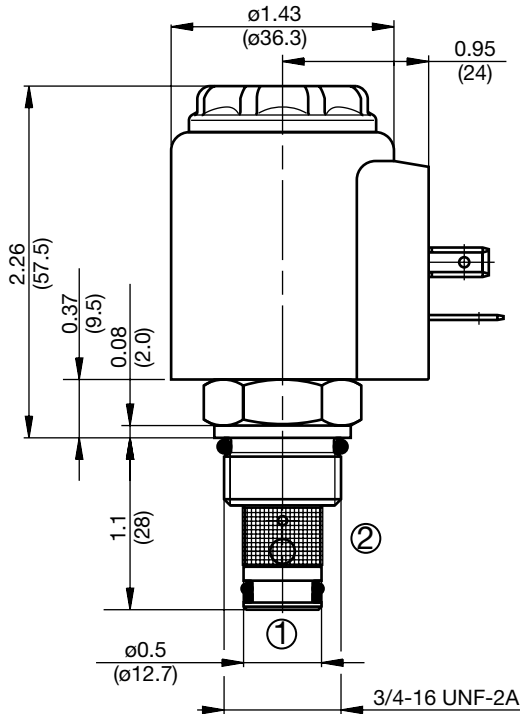
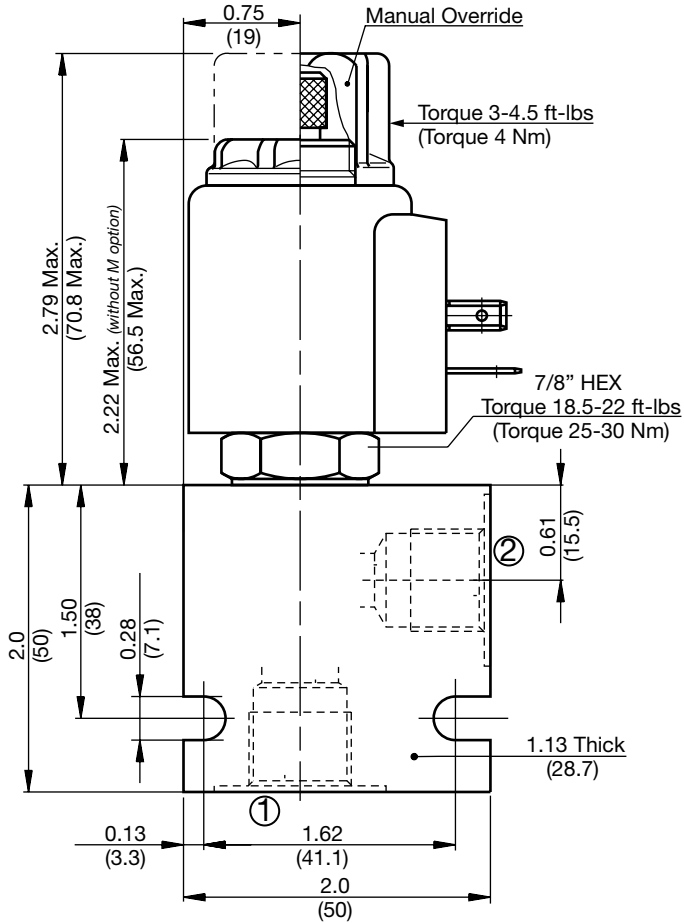

All measurements in inches (mm).
Subject to technical modifications

Model Code

WS08Z-30 M-C-N-24 DS

- Valve Model** _____
- Override Option** _____
blank = No manual override
M = Manual override, screw type
- Body & Ports** _____
C = Cartridge only
AS6 = SAE-6 Ports, aluminum body
SS6 = SAE-6 Ports, steel body
- Seals** _____
N = Buna-N
V = Viton®
- Coil Voltage** _____
0 = No coil, cartridge only
- DC** _____
12 = 12 VDC
24 = 24 VDC
36 = 36 VDC
110 = 110 VDC (only available with connector DG)
- AC** _____
24 = 24 VAC
115 = 115 VAC (AC coils internally full wave rectified)
230 = 230 VAC
- Coil Connector** _____
DC DG = EN 175301-803-A
DS = Dual spade (SAEJ858a)*
DL = Leadwires (2) - 18" long (46 cm)*
DW = WeatherPak™ on leadwires - 9.5" long (24 cm)*
DN = Deutsch™ DT04-2P, molded, axial (IP69K Rated)*
DT = Amp Junior Timer™, molded, radial mount*
- AC AG** = EN 175301-803-A

Coil Model 40-1836

For other coil connector types consult factory

*Coils with internal diode are available, consult factory.

Standard Line Bodies*

Code	Part No	Material	Pressure Rating	Weight
FH082-AS6	03011409	Aluminum, anodized	3500 psi (245 bar)	0.34 lbs (0.15 kg)
FH082-SS6	00560917	Steel, Zinc plated	6000 psi (420 bar)	1.0 lbs (0.45 kg)

*Please refer to Line Bodies & Cavities section for details

SOLENOID VALVES

WS08ZR-01

Poppet Type, Normally Closed, Pilot Operated, Free Reverse Flow

Up to 10 gpm (38 l/min) • 5000 psi (350 bar)

Hydraulic Symbol

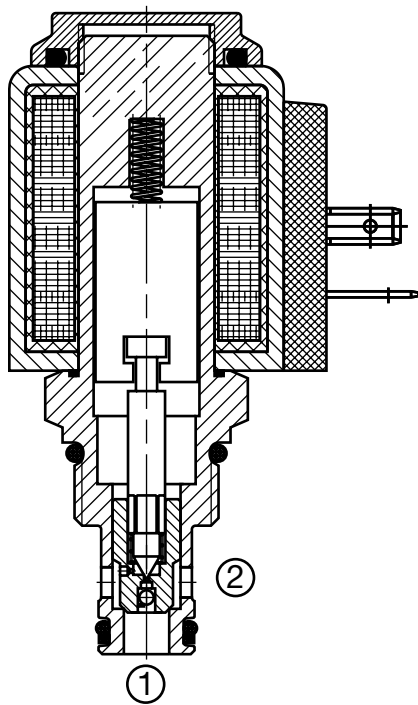
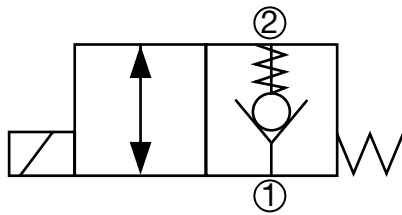

Description

A screw-in cartridge, solenoid operated, 2-way, 2 position, normally closed, pilot operated, poppet type with filter screen on inlet port, intended for use as a uni-directional blocking or load holding device in hydraulic circuits requiring low internal leakage.

Operation

When de-energized the WS08ZR blocks flow from port 2 to port 1, while allowing flow from port 1 to port 2. When energized the poppet lifts allowing bi-directional flow between port 1 and port 2.

Operation of Manual Override Option: To override, remove the coil nut, turn the override knurled knob counterclockwise until it stops. The override will remain activated until the knob is turned clockwise to original position. The manual override option is intended for emergency use, not for continuous duty operation.

Features

- Screw type manual override option
- Free reverse flow

Specifications

Operating Pressure	5000 psi (350 bar)
Nominal Flow	10 gpm (38 l/min)
Internal Leakage	Leaktight, less than 5 drops/min. at 5000 psi (0.25 cc/min at 350 bar)
Fluid Operating Temp. Range	-4° to 248°F (-20° to 120°C) (Consult factory for usage at temp. outside range.)
Ambient Temperature Range	-4° to 140°F (-20° to 60°C)
Coil Duty Rating	Continuous from 85% to 115% of nominal voltage
Current Draw @ 68°F (20°C)	1.5 A at 12VDC; 0.8 A at 24VDC
Min. Pull-in Voltage @ 68°F (20°C)	85% of nominal @ 5000 psi (350 bar)
Response Time (typical)	Energized 35 ms De-energized 50 ms
Fluid Compatibility	Mineral-based or synthetics with lubricating properties
Viscosity	50 to 2000 SUS (7.4 to 420 cSt)
Filtration	21/19/16 or cleaner (per ISO 4406). Use with filter rated $\beta_{10} \geq 200$.
Installation	No orientation restrictions
Cavity	FC08-2 (see Line Bodies & Cavities section)
Cavity Tools	Rougher: 02580090 Finisher: 02580091
Cartridge Weight	0.31 Lbs. (0.14 kg)
Coil Weight	0.42 Lbs. (0.19 kg)
Cartridge Material	Steel with hardened work surfaces. Zinc-plated exposed surfaces. Buna N or Viton® o-rings. PTFE back-up rings.
Coil Material	Class N high temperature magnet wire, steel shell, polyamid encapsulation.
Seal Kits	Buna-N FS082-N P/N: 03033920 Viton® FS082-V P/N: 03051756

Performance

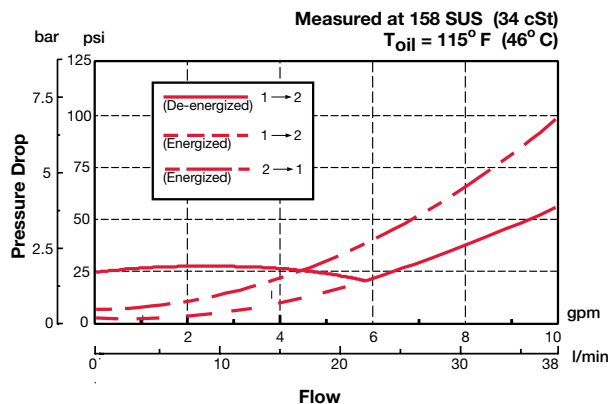

Dimensions

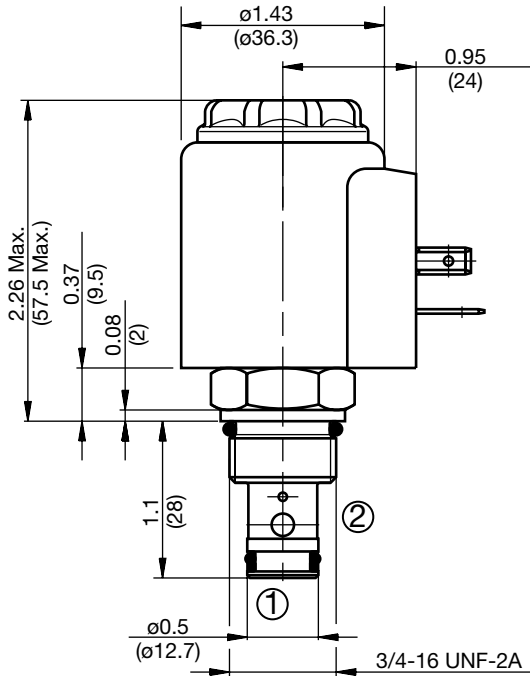
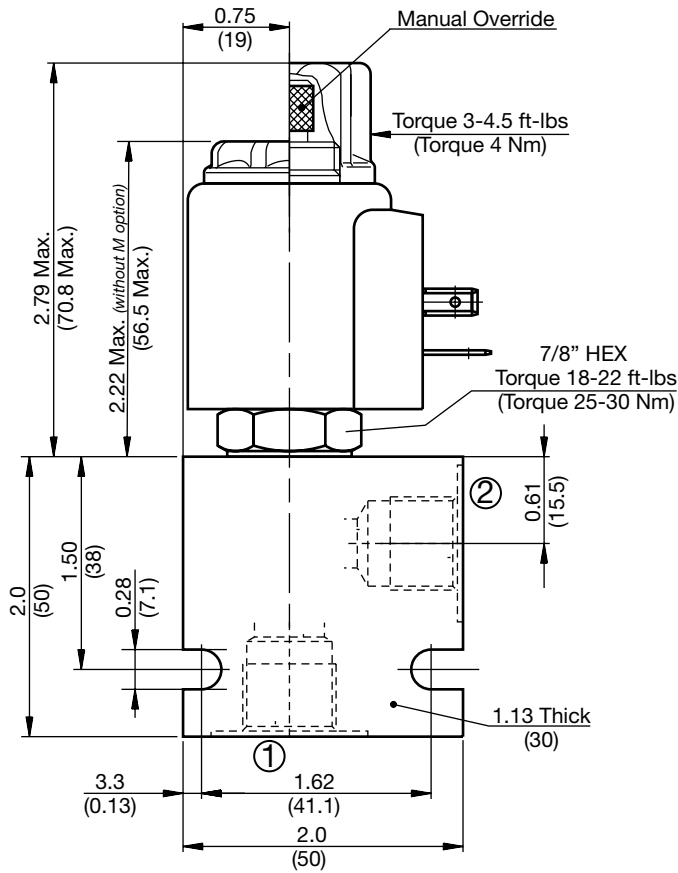

Model Code

WS08ZR-01 M-C-N-24 DN

Valve Model

Override Option

blank = No manual override
M = Manual override, screw type

Body & Ports

C = Cartridge only
AS6 = SAE-6 Ports, aluminum body
SS6 = SAE-6 Ports, steel body

Seals

N = Buna-N
V = Viton®

Coil Voltage

0 = No coil, cartridge only

DC

12 = 12 VDC
24 = 24 VDC
36 = 36 VDC
110 = 110 VDC (only available with connector DG)

AC

24 = 24 VAC
115 = 115 VAC (AC coils internally full wave rectified)
230 = 230 VAC

Coil Connector

DC DG = EN 175301-803-A
DS = Dual spade (SAEJ858a)*
DL = Leadwires (2) - 18" long (46 cm)*
DW = WeatherPak™ on leadwires - 9.5" long (24 cm)*
DN = Deutsch™ DT04-2P, molded, axial (IP69K Rated)*
DT = Amp Junior Timer™, molded, radial mount*

AC AG = EN 175301-803-A

Coil Model 40-1836

For other coil connector types consult factory

*Coils with internal diode are available, consult factory.

All measurements in inches (mm).
Subject to technical modifications

PN#02087369 / 10.19 / CHD1110-1389

Standard Line Bodies*

Code	Part No	Material	Pressure Rating	Weight
FH082-AS6	03011409	Aluminum, anodized	3500 psi (245 bar)	0.34 lbs (0.15 kg)
FH082-SS6	00560917	Steel, Zinc plated	6000 psi (420 bar)	1.0 lbs (0.45 kg)

*Please refer to Line Bodies & Cavities section for details

SOLENOID VALVES

WS10ZR-01

Poppet Type, Normally Closed, Pilot Operated, Free Reverse Flow

Up to 20 gpm (75 l/min) • 5000 psi (350 bar)

Hydraulic Symbol

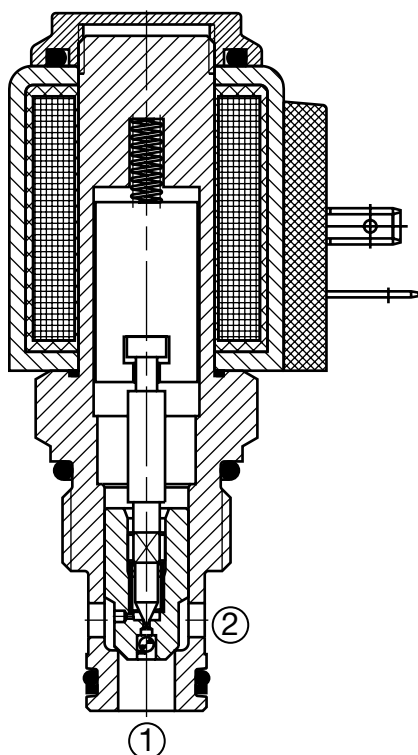
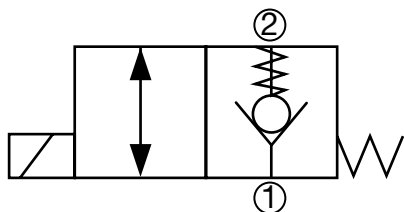

Description

A screw-in cartridge, solenoid operated, 2-way, 2 position, normally closed, pilot operated, poppet type intended for use as a uni-directional blocking or load holding device in hydraulic circuits requiring low internal leakage.

Operation

When de-energized the WS10ZR blocks flow from port 2 to port 1, while allowing flow from port 1 to port 2. When energized the poppet lifts allowing bi-directional flow between port 1 and port 2.

Operation of Manual Override Option: To override, remove the coil nut, turn the override knurled knob counterclockwise until it stops. The override will remain activated until the knob is turned clockwise to original position. The manual override option is intended for emergency use, not for continuous duty operation.

Features

- Screw type manual override option
- Free reverse flow

Specifications

Operating Pressure	5000 psi (350 bar)	
Nominal Flow	20 gpm (75 l/min)	
Internal Leakage	Leaktight, less than 5 drops/min. at 5000 psi (0.25 cc/min at 350 bar)	
Fluid Operating Temp. Range	-4° to 248°F (-20° to 120°C) (Consult factory for usage at temp. outside range.)	
Ambient Temperature Range	-4° to 140°F (-20° to 60°C)	
Coil Duty Rating	Continuous from 85% to 115% of nominal voltage	
Current Draw @ 68°F (20°C)	1.5 A at 12VDC; 0.8 A at 24VDC	
Min. Pull-in Voltage @ 68°F (20°C)	85% of nominal @ 5000 psi (350 bar)	
Response Time (typical)	Energized	35 ms
	De-energized	60 ms
Fluid Compatibility	Mineral-based or synthetics with lubricating properties	
Viscosity	50 to 2000 SUS (7.4 to 420 cSt)	
Filtration	21/19/16 or cleaner (per ISO 4406). Use with filter rated $\beta_{10} \geq 200$.	
Installation	No orientation restrictions	
Cavity	FC10-2 (see Line Bodies & Cavities section)	
Cavity Tools	Rougher:	02580274
	Finisher:	02580247
Cartridge Weight	0.40 Lbs. (0.18 kg)	
Coil Weight	0.42 Lbs. (0.19 kg)	
Cartridge Material	Steel with hardened work surfaces. Zinc-plated exposed surfaces. Buna N or Viton® o-rings. PTFE back-up rings.	
Coil Material	Class N high temperature magnet wire, steel shell, polyamid encapsulation.	
Seal Kits	Buna-N	FS102-N P/N: 03033872
	Viton®	FS102-V P/N: 03051757

Performance

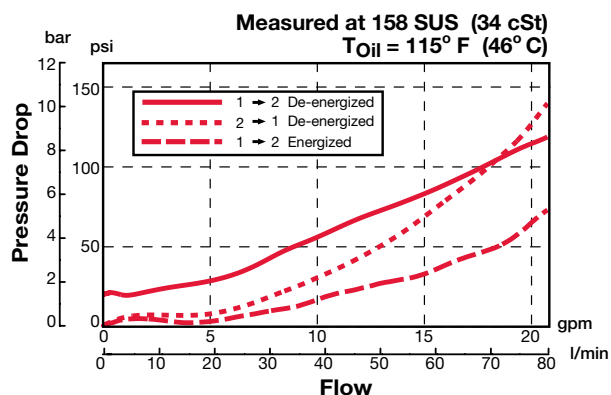

Dimensions

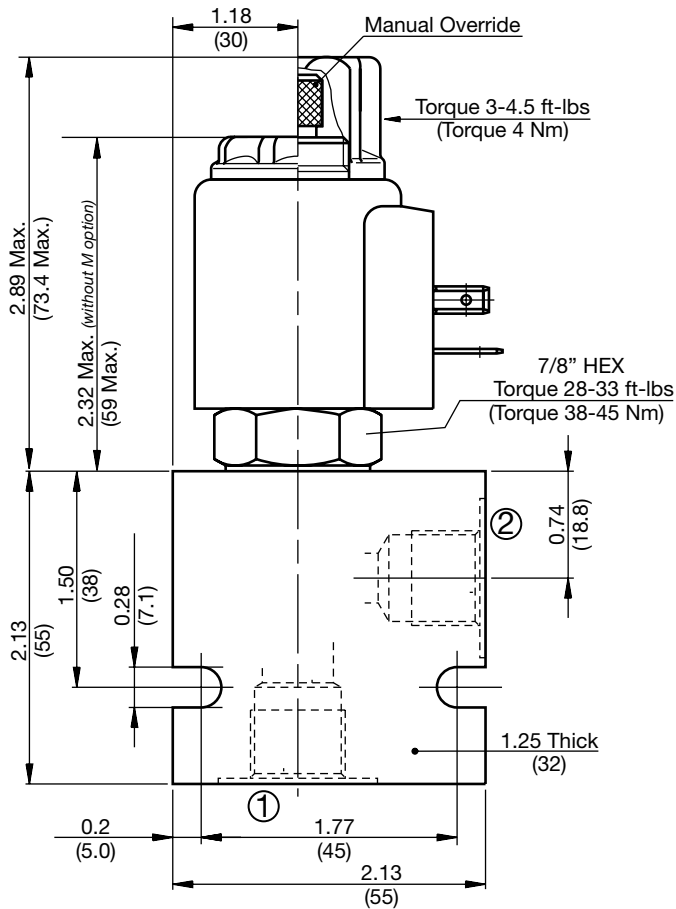

Model Code

WS10ZR-01 M-C-N-24 DS

Valve Model

Override Option

- blank = No manual override
- M = Manual override, screw type

Body & Ports

- C = Cartridge only
- AS8 = SAE-8 Ports, aluminum body
- SS8 = SAE-8 Ports, steel body

Seals

- N = Buna-N
- V = Viton®

Coil Voltage

- 0 = No coil, cartridge only

DC

- 12 = 12 VDC
- 24 = 24 VDC
- 36 = 36 VDC
- 110 = 110 VDC (only available with connector DG)

AC

- 24 = 24 VAC
- 115 = 115 VAC (AC coils internally full wave rectified)
- 230 = 230 VAC

Coil Connector

- DC DG = EN 175301-803-A
- DS = Dual spade (SAEJ858a)*
- DL = Leadwires (2) - 18" long (46 cm)*
- DW = WeatherPak™ on leadwires - 9.5" long (24 cm)*
- DN = Deutsch™ DT04-2P, molded, axial (IP69K Rated)*
- DT = Amp Junior Timer™, molded, radial mount*

- AC AG = EN 175301-803-A

Coil Model 40-1836

For other coil connector types consult factory

*Coils with internal diode are available, consult factory.

All measurements in inches (mm).
Subject to technical modifications

PN#02087369 / 10.19 / CHD1110-1389

Standard Line Bodies*

Code	Part No	Material	Pressure Rating	Weight
FH102-AS8	03037778	Aluminum, anodized	3500 psi (245 bar)	0.40 lbs (0.18 kg)
FH102-SS6	03037612	Steel, Zinc plated	6000 psi (420 bar)	1.16 lbs (0.53 kg)

*Please refer to Line Bodies & Cavities section for details

SOLENOID VALVES

WS12ZR-01

Poppet Type, Normally Closed, Pilot Operated, Free Reverse Flow

Up to 29 gpm (110 l/min) • 5000 psi (350 bar)

Hydraulic Symbol

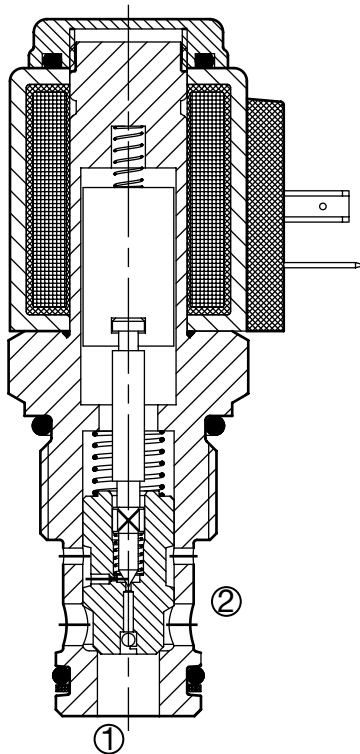
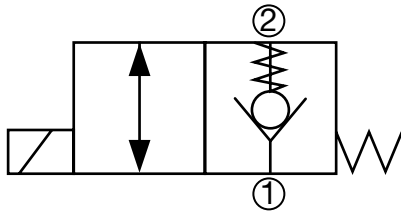

Description

A screw-in cartridge, solenoid operated, 2-way, 2 position, normally closed, pilot operated, poppet type intended for use as a uni-directional blocking or load holding device in hydraulic circuits requiring low internal leakage.

Operation

When de-energized the WS12ZR blocks flow from port 2 to port 1, while allowing flow from port 1 to port 2. When energized the poppet lifts, allowing bi-directional flow between port 1 and port 2.

Operation of Manual Override Option: To override, remove the coil nut, turn the override knurled knob counterclockwise until it stops. The override will remain activated until the knob is turned clockwise to original position. The manual override option is intended for emergency use, not for continuous duty operation.

Features

- Screw type manual override option
- Free reverse flow

Specifications

Operating Pressure	5000 psi (350 bar)
Nominal Flow	29 gpm (110 l/min)
Internal Leakage	Leaktight, less than 5 drops/min. at 5000 psi (0.25 cc/min at 350 bar)
Fluid Operating Temp. Range	-4° to 248°F (-20° to 120°C) (Consult factory for usage at temp. outside range.)
Ambient Temperature Range	-4° to 140°F (-20° to 60°C)
Coil Duty Rating	Continuous from 85% to 115% of nominal voltage
Current Draw @ 68°F (20°C)	1.5 A at 12VDC; 0.8 A at 24VDC
Min. Pull-in Voltage @ 68°F (20°C)	85% of nominal @ 5000 psi (350 bar)
Response Time (typical)	Energized 35 ms De-energized 70 ms
Fluid Compatibility	Mineral-based or synthetics with lubricating properties
Viscosity	50 to 2000 SUS (7.4 to 420 cSt)
Filtration	21/19/16 or cleaner (per ISO 4406). Use with filter rated $\beta_{10} \geq 200$.
Installation	No orientation restrictions
Cavity	FC12-2 (see Line Bodies & Cavities section)
Cavity Tools	Rougher: 02580667 Finisher: 02580668
Cartridge Weight	0.60 Lbs. (0.27 kg)
Coil Weight	0.42 Lbs. (0.19 kg)
Cartridge Material	Steel with hardened work surfaces. Zinc-plated exposed surfaces. Buna N or Viton® o-rings. PTFE back-up rings.
Coil Material	Class N high temperature magnet wire, steel shell, polyamid encapsulation.
Seal Kits	Buna-N FS122-N P/N: 03071298 Viton® FS122-V P/N: 03071299

Performance

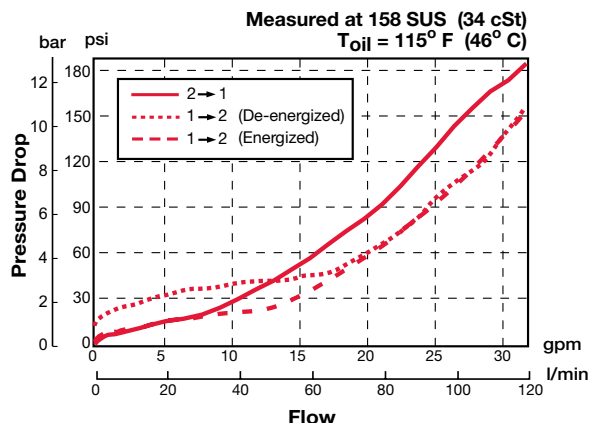

Dimensions

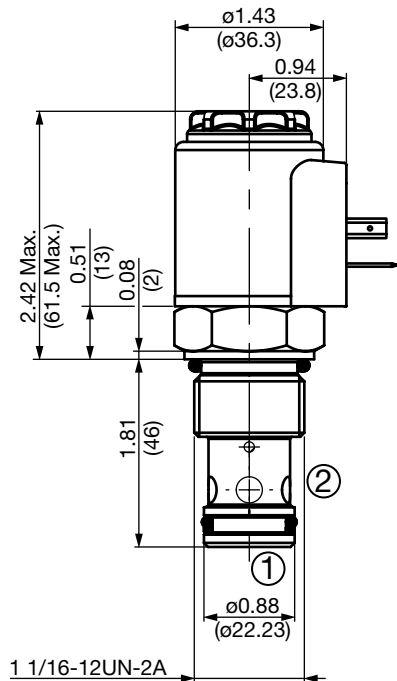
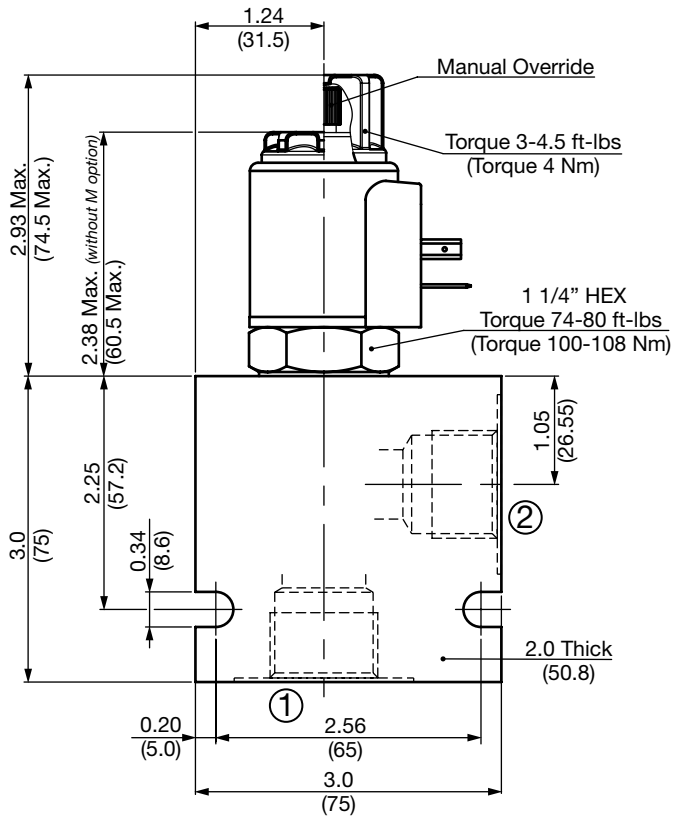

All measurements in inches (mm).
Subject to technical modifications

Model Code

WS12ZR-01 M-C-N-24 DS

- Valve Model** _____
- Override Option** _____
 blank = No manual override
 M = Manual override, screw type
- Body & Ports** _____
 C = Cartridge only
 AS12 = SAE-12 Ports, aluminum body
 SS12 = SAE-12 Ports, steel body
- Seals** _____
 N = Buna-N
 V = Viton®
- Coil Voltage** _____
 0 = No coil, cartridge only
- DC** _____
 12 = 12 VDC
 24 = 24 VDC
 36 = 36 VDC
 110 = 110 VDC (only available with connector DG)
- AC** _____
 24 = 24 VAC
 115 = 115 VAC (AC coils internally full wave rectified)
 230 = 230 VAC
- Coil connector** _____
 DC _____
 DG = EN 175301-803-A
 DS = Dual spade (SAEJ858a)*
 DL = Leadwires (2) - 18" long (46 cm)*
 DW = WeatherPak™ on leadwires - 9.5" long (24 cm)*
 DN = Deutsch™ DT04-2P, molded, axial (IP69K Rated)*
 DT = Amp Junior Timer™, molded, radial mount*
- AC AG** = EN 175301-803-A

Coil Model 40-1836

For other coil connector types consult factory

*Coils with internal diode are available, consult factory.

Standard Line Bodies*

Code	Part No	Material	Pressure Rating	Weight
FH122-AS12	03053845	Aluminum, anodized	3500 psi (245 bar)	1.39 lbs (0.63 kg)
FH122-SS12	03053772	Steel, Zinc plated	6000 psi (420 bar)	4.16 lbs (1.89 kg)

*Please refer to Line Bodies & Cavities section for details

SOLENOID VALVES

WS16ZR-01

Poppet Type, Normally Closed, Pilot Operated, Free Reverse Flow

Up to 40 gpm (150 l/min) • 5000 psi (350 bar)

Hydraulic Symbol

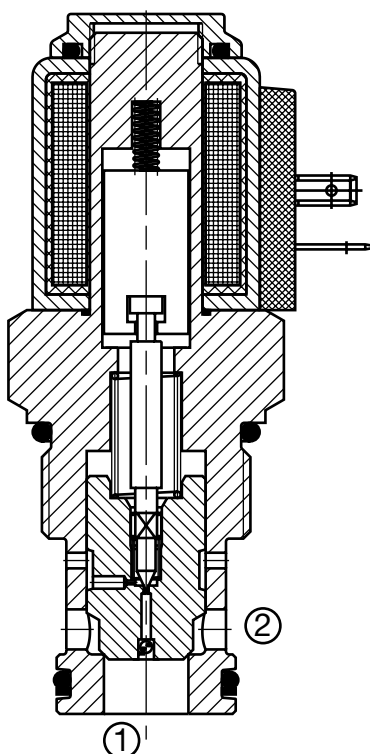
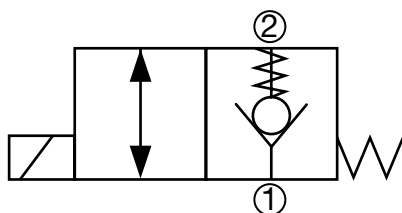

Description

A screw-in cartridge, solenoid operated, 2-way, 2 position, normally closed, pilot operated, poppet type intended for use as a uni-directional blocking or load holding device in hydraulic circuits requiring low internal leakage.

Operation

When de-energized the WS16ZR blocks flow from port 2 to port 1, while allowing flow from port 1 to port 2. When energized the poppet lifts, allowing bi-directional flow between port 1 and port 2.

Operation of Manual Override Option: To override, remove the coil nut, turn the override knurled knob counterclockwise until it stops. The override will remain activated until the knob is turned clockwise to original position. The manual override option is intended for emergency use, not for continuous duty operation.

Features

- Screw type manual override option
- Free reverse flow

Specifications

Operating Pressure	5000 psi (350 bar)
Nominal Flow	40 gpm at 4060 psi (150 l/min at 280 bar) 26 gpm at 5000 psi (100 l/min at 350 bar)
Internal Leakage	Leaktight, less than 5 drops/min. at 5000 psi (0.25 cc/min at 350 bar)
Fluid Operating Temp. Range	-4° to 248°F (-20° to 120°C) (Consult factory for usage at temp. outside range.)
Ambient Temperature Range	-4° to 140°F (-20° to 60°C)
Coil Duty Rating	Continuous from 85% to 115% of nominal voltage
Current Draw @ 68°F (20°C)	1.5 A at 12VDC; 0.8 A at 24VDC
Min. Pull-in Voltage @ 68°F (20°C)	85% of nominal @ 5000 psi (350 bar)
Response Time (typical)	Energized 35 ms De-energized 70 ms
Fluid Compatibility	Mineral-based or synthetics with lubricating properties
Viscosity	50 to 2000 SUS (7.4 to 420 cSt)
Filtration	21/19/16 or cleaner (per ISO 4406). Use with filter rated $\beta_{10} \geq 200$.
Installation	No orientation restrictions
Cavity	FC16-2 (see Line Bodies & Cavities section)
Cavity Tools	Rougher: 02580250 Finisher: 02580251
Cartridge Weight	1.37 Lbs. (0.62 kg)
Coil Weight	0.42 Lbs. (0.19 kg)
Cartridge Material	Steel with hardened work surfaces. Zinc-plated exposed surfaces. Buna N or Viton® o-rings. PTFE back-up rings.
Coil Material	Class N high temperature magnet wire, steel shell, polyamid encapsulation.
Seal Kits	Buna-N FS162-N P/N: 03052427 Viton® FS162-V P/N: 03051758

Performance

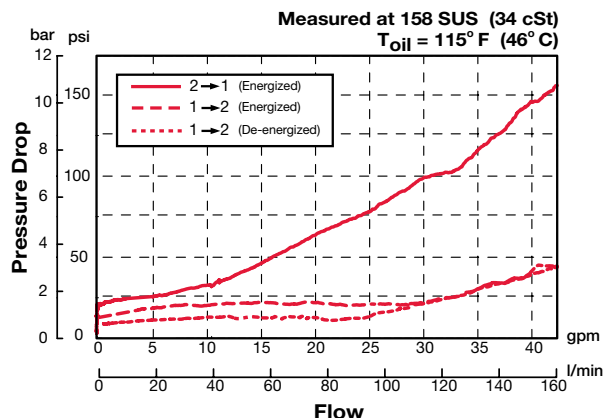

Dimensions

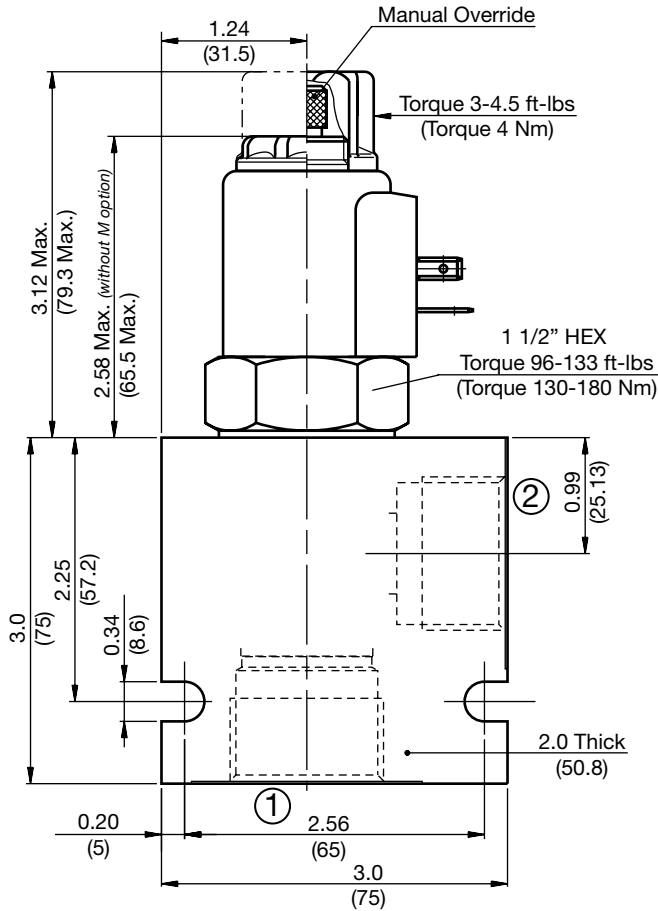

Model Code

WS16ZR-01 M-C-N-24-DS

Valve Model

Override Option

- blank = No manual override
- M = Manual override, screw type

Body & Ports

- C = Cartridge only
- AS16 = SAE-16 Ports, aluminum body
- SS16 = SAE-16 Ports, steel body

Seals

- N = Buna-N
- V = Viton®

Coil Voltage

- 0 = No coil, cartridge only
- DC 12 = 12 VDC
- 24 = 24 VDC
- 36 = 36 VDC
- 110 = 110 VDC (only available with connector DG)
- AC 24 = 24 VAC
- 115 = 115 VAC (AC coils internally full wave rectified)
- 230 = 230 VAC

Coil Connector

- DC DG = EN 175301-803-A
- DS = Dual spade (SAEJ858a)*
- DL = Leadwires (2) - 18" long (46 cm)*
- DW = WeatherPak™ on leadwires - 9.5" long (24 cm)*
- DN = Deutsch™ DT04-2P, molded, axial (IP69K Rated)*
- DT = Amp Junior Timer™, molded, radial mount*
- AC AG = EN 175301-803-A

Coil Model 40-1836

For other coil connector types consult factory

*Coils with internal diode are available, consult factory.

All measurements in inches (mm).
Subject to technical modifications

PN#02087369 / 10.19 / CHD1110-1389

Standard Line Bodies*

Code	Part No	Material	Pressure Rating	Weight
FH162-AS16	03037195	Aluminum, anodized	3500 psi (245 bar)	1.2 lbs (0.55 kg)
FH162-SS16	03032655	Steel, Zinc plated	6000 psi (420 bar)	3.56 lbs (1.62 kg)

*Please refer to Line Bodies & Cavities section for details

SOLENOID VALVES

WS08ZR-01J

Poppet Type, Normally Closed, Pilot Operated, Free Reverse Flow

Up to 10 gpm (38 l/min) • 5000 psi (350 bar)

Hydraulic Symbol

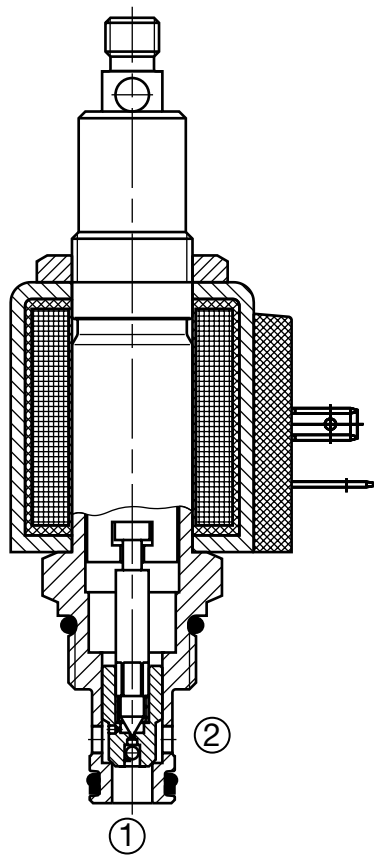
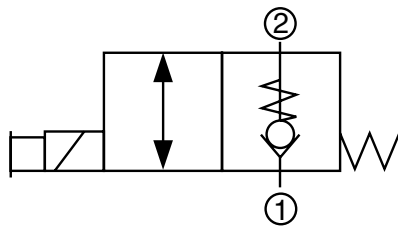

Description

A screw-in cartridge, solenoid operated, 2-way, 2 position, normally closed, pilot operated, poppet type with pull type, spring return manual override, intended for use as a uni-directional blocking or load holding device in

Operation

When de-energized the WS08ZR-01J blocks flow from port 2 to port 1, while allowing flow from port 1 to port 2. When energized the poppet lifts, allowing bi-directional flow between port 1 and port 2.

Operation of Manual Override Option: To manually override pull and hold the override stem. This override is not detented. The override stem has a male thread M8X1.25 and hole for a cable attachment. If a cable is used, the internal spring may not provide enough force to overcome internal cable friction. An external means of returning the cable must be provided by the user. The manual override option is intended for emergency use, not for continuous duty operation.

Features

- Rugged manual override design with thread and hole for a handle or cable attachment.

Specifications

Operating Pressure	5000 psi (350 bar)
Nominal Flow	10 gpm (38 l/min)
Internal Leakage	Leaktight, less than 5 drops/min. at 5000 psi (0.25 cc/min at 350 bar)
Manual Override Pull Force	38 - 40.5 bs (150 - 180 N) Max. permissible pull force
Fluid Operating Temp. Range	-4° to 248°F (-20° to 120°C) (Consult factory for usage at temp. outside range.)
Ambient Temperature Range	-4° to 140°F (-20° to 60°C)
Coil Duty Rating	Continuous from 85% to 115% of nominal voltage
Current Draw @ 68°F (20°C)	1.5 A at 12VDC; 0.8 A at 24VDC
Min. Pull-in Voltage @ 68°F (20°C)	85% of nominal @ 5000 psi (350 bar)
Response Time (typical)	Energized 35 ms De-energized 50 ms
Fluid Compatibility	Mineral-based or synthetics with lubricating properties
Viscosity	50 to 2000 SUS (7.4 to 420 cSt)
Filtration	21/19/16 or cleaner (per ISO 4406). Use with filter rated $\beta_{10} \geq 200$.
Installation	No orientation restrictions
Cavity	FC08-2 (see Line Bodies & Cavities section)
Cavity Tools	Rougher: 02580090 Finisher: 02580091
Cartridge Weight	0.31 Lbs. (0.14 kg)
Coil Weight	0.42 Lbs. (0.19 kg)
Cartridge Material	Steel with hardened work surfaces. Zinc-plated exposed surfaces. Buna N or Viton® o-rings. PTFE back-up rings.
Coil Material	Class N high temperature magnet wire, steel shell, polyamid encapsulation.
Seal Kits	Buna-N P/N: 03033920 Viton® P/N: 03051756

Performance

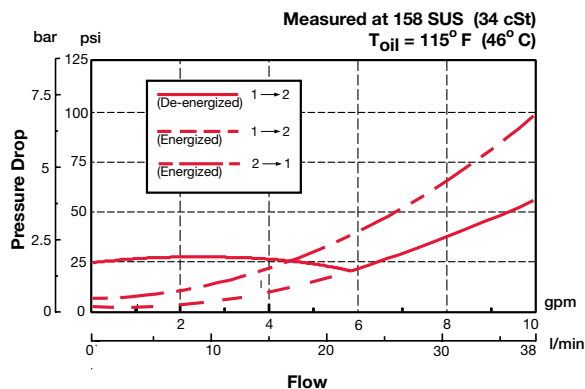

Dimensions

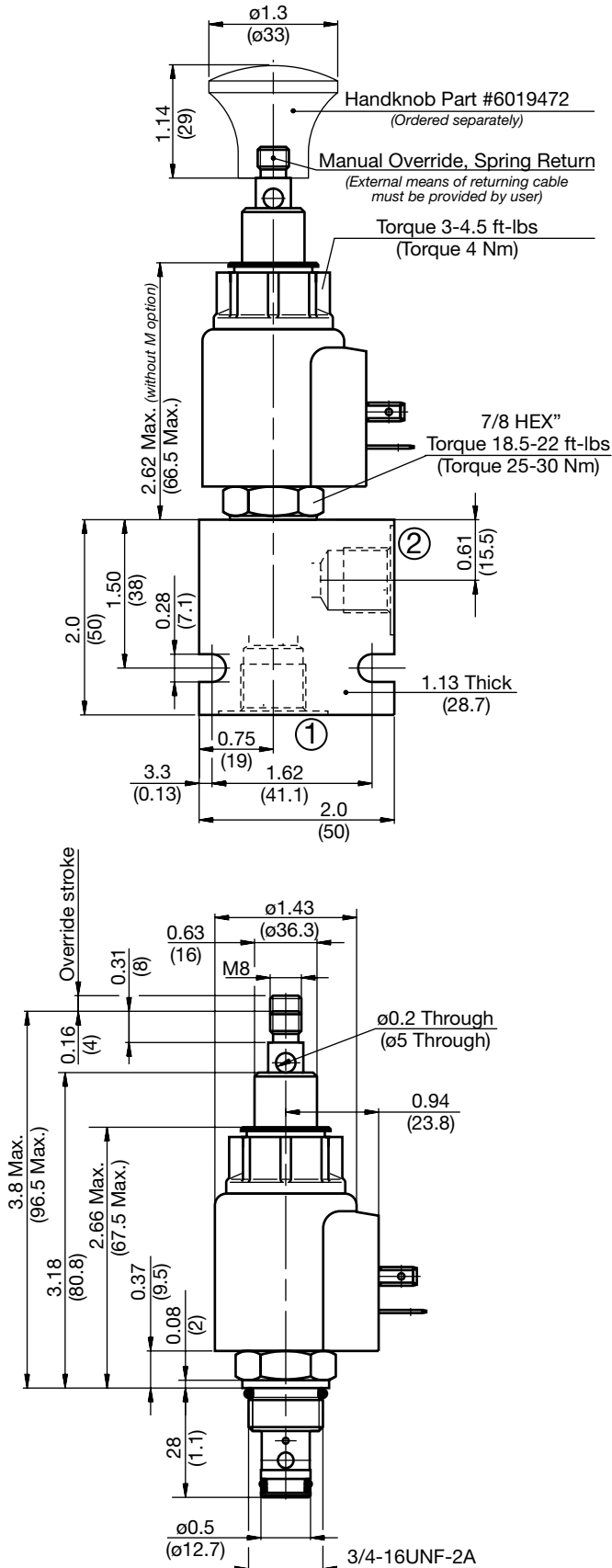

All measurements in inches (mm).
Subject to technical modifications

PN#02087369 / 10.19 / CHD1110-1389

Model Code

WS08ZR-01 J-C-N-24 DN

Valve Model

Override Option

J = Manual override, pull type, spring return

Body & Ports

C = Cartridge only
AS6 = SAE-6 Ports, aluminum body
SS6 = SAE-6 Ports, steel body

Seals

N = Buna-N
V = Viton®

Coil Voltage

0 = No coil, cartridge only

DC

12 = 12 VDC
24 = 24 VDC
36 = 36 VDC
110 = 110 VDC (only available with connector DG)

AC

24 = 24 VAC
115 = 115 VAC (AC coils internally full wave rectified)
230 = 230 VAC

Coil Connector

DC

DG = EN 175301-803-A
DS = Dual spade (SAEJ858a)*
DL = Leadwires (2) - 18" long (46 cm)*
DW = WeatherPak™ on leadwires - 9.5" long (24 cm)*
DN = Deutsch™ DT04-2P, molded, axial (IP69K Rated)*
DT = Amp Junior Timer™, molded, radial mount*

AC

AG = EN 175301-803-A

Coil Model 40-1836

For other coil connector types consult factory

*Coils with internal diode are available, consult factory.

Standard Line Bodies*

Code	Part No	Material	Pressure Rating	Weight
FH082-AS6	03011409	Aluminum, anodized	3500 psi (245 bar)	0.34 lbs (0.15 kg)
FH082-SS6	00560917	Steel, Zinc plated	6000 psi (420 bar)	1.0 lbs (0.45 kg)

*Please refer to Line Bodies & Cavities section for details

SOLENOID VALVES

WS08ZR-30

Poppet Type, Normally Closed, Pilot Operated, Free Reverse Flow

Up to 8 gpm (38 l/min) • 5000 psi (350 bar)

Hydraulic Symbol

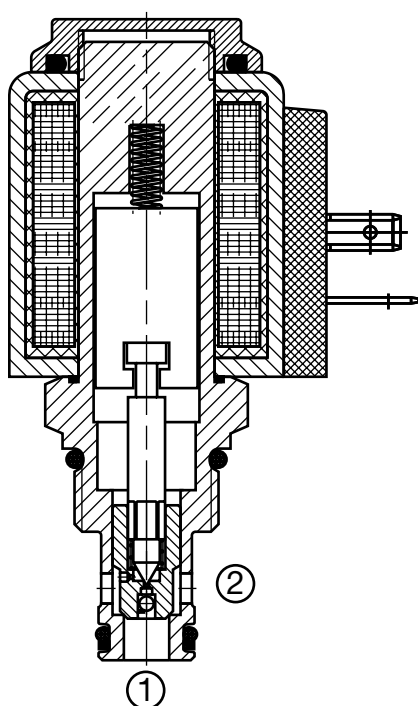
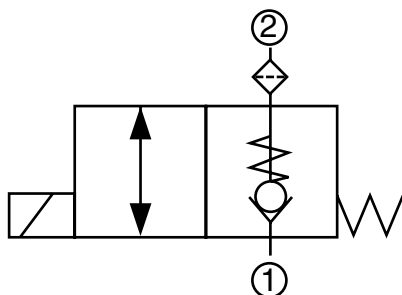

Description

A screw-in cartridge, solenoid operated, 2-way, 2 position, normally closed, pilot operated, poppet type, with filter screen on inlet port, intended for use as a uni-directional blocking or load holding device in hydraulic circuits requiring low internal leakage.

Operation

When de-energized the WS08ZR blocks flow from port 2 to port 1, while allowing flow from port 1 to port 2. When energized the poppet lifts allowing bi-directional flow between port 1 and port 2.

Operation of Manual Override Option: To override, remove the coil nut, turn the override knurled knob counterclockwise until it stops. The override will remain activated until the knob is turned clockwise to original position. The manual override option is intended for emergency use, not for continuous duty operation.

Features

- Filter screen on the inlet port for protection from contamination
- Screw type manual override option
- Free reverse flow

Specifications

Operating Pressure	5000 psi (350 bar)
Nominal Flow	8 gpm (30 l/min)
Internal Leakage	Leaktight, less than 5 drops/min. at 5000 psi (0.25 cc/min at 350 bar)
Fluid Operating Temp. Range	-4° to 248°F (-20° to 120°C) (Consult factory for usage at temp. outside range.)
Ambient Temperature Range	-4° to 140°F (-20° to +60°C)
Coil Duty Rating	Continuous from 85% to 115% of nominal voltage
Current Draw @ 68°F (20°C)	1.5 A at 12VDC; 0.8 A at 24VDC
Min. Pull-in Voltage @ 68°F (20°C)	85% of nominal @ 5000 psi (350 bar)
Response Time (typical)	Energized 35 ms De-energized 50 ms
Fluid Compatibility	Mineral-based or synthetics with lubricating properties
Viscosity	50 to 2000 SUS (7.4 to 420 cSt)
Filtration	21/19/16 or cleaner (per ISO 4406). Use with filter rated $\beta_{10} \geq 200$.
Filter screen	300 μ m mesh
Installation	No orientation restrictions
Cavity	FC08-2 (see <i>Line Bodies & Cavities</i> section)
Cavity Tools	Rougher: 02580090 Finisher: 02580091
Cartridge Weight	0.31 Lbs. (0.14 kg)
Coil Weight	0.42 Lbs. (0.19 kg)
Cartridge Material	Steel with hardened work surfaces. Zinc-plated exposed surfaces. Buna N or Viton® o-rings. PTFE back-up rings.
Coil Material	Class N high temperature magnet wire, steel shell, polyamid encapsulation.
Seal Kits	Buna-N FS082-N P/N: 03033920 Viton® FS082-V P/N: 03051756

Performance

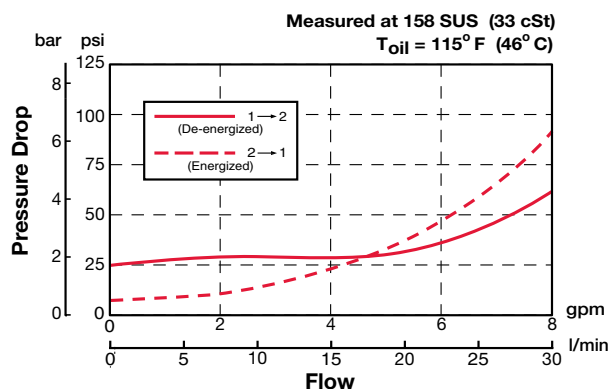

Dimensions

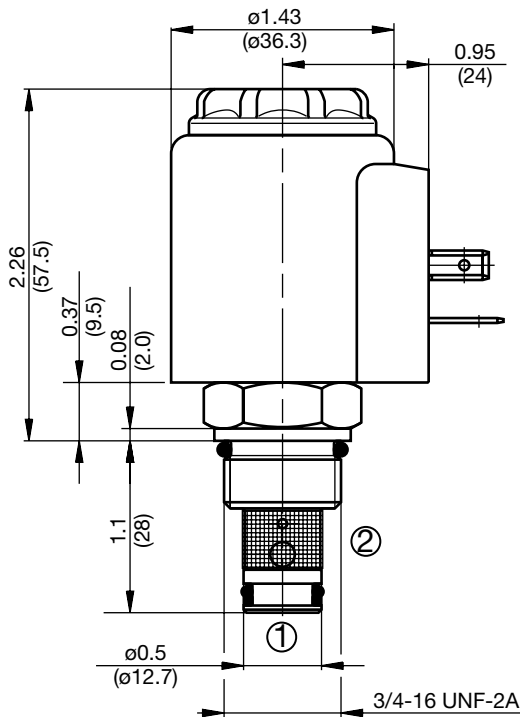
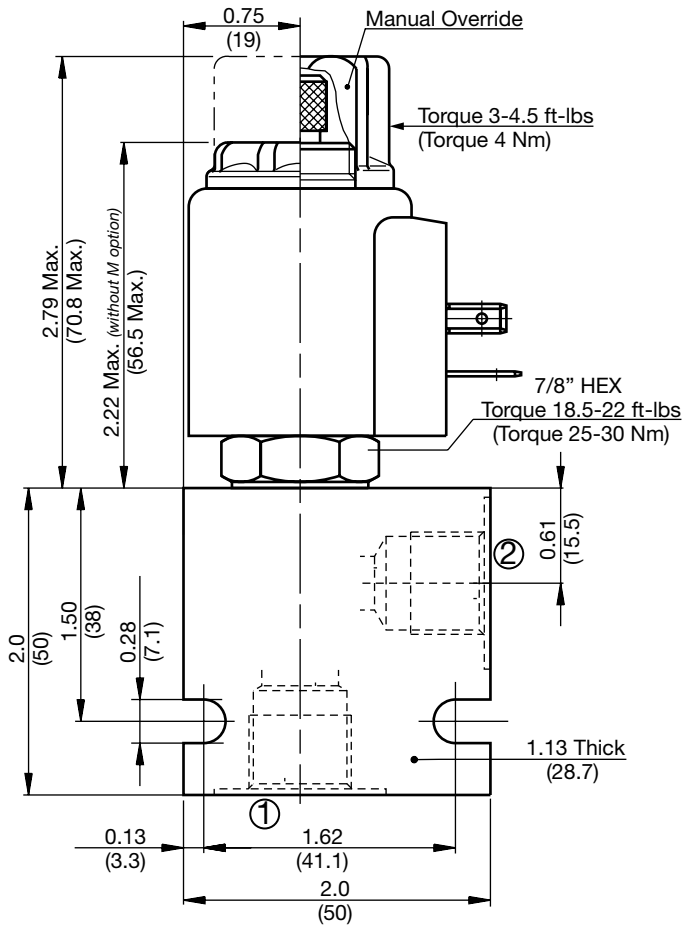

All measurements in inches (mm).
Subject to technical modifications

Model Code

WS08ZR-30 M-C-N-24 DS

Valve Model

Override Option

blank = No manual override
M = Manual override, screw type

Body & Ports

C = Cartridge only
AS6 = SAE-6 Ports, aluminum body
SS6 = SAE-6 Ports, steel body

Seals

N = Buna-N
V = Viton®

Coil Voltage

0 = No coil, cartridge only

DC

12 = 12 VDC
24 = 24 VDC
36 = 36 VDC
110 = 110 VDC (only available with connector DG)

AC

24 = 24 VAC
115 = 115 VAC (AC coils internally full wave rectified)
230 = 230 VAC

Coil Connector

DC

DG = EN 175301-803-A
DS = Dual spade (SAEJ858a)*
DL = Leadwires (2) - 18" long (46 cm)*
DW = WeatherPak™ on leadwires - 9.5" long (24 cm)*
DN = Deutsch™ DT04-2P, molded, axial (IP69K Rated)*
DT = Amp Junior Timer™, molded, radial mount*

AC

AG = EN 175301-803-A

Coil Model 40-1836

For other coil connector types consult factory

*Coils with internal diode are available, consult factory.

Standard Line Bodies*

Code	Part No	Material	Pressure Rating	Weight
FH082-AS6	03011409	Aluminum, anodized	3500 psi (245 bar)	0.34 lbs (0.15 kg)
FH082-SS6	00560917	Steel, Zinc plated	6000 psi (420 bar)	1.0 lbs (0.45 kg)

*Please refer to Line Bodies & Cavities section for details

SOLENOID VALVES

WS08V-01

Poppet Type, Bi-directional, Normally Open, Direct Acting

Up to 5 gpm (19 l/min) • 5000 psi (350 bar)

Hydraulic Symbol

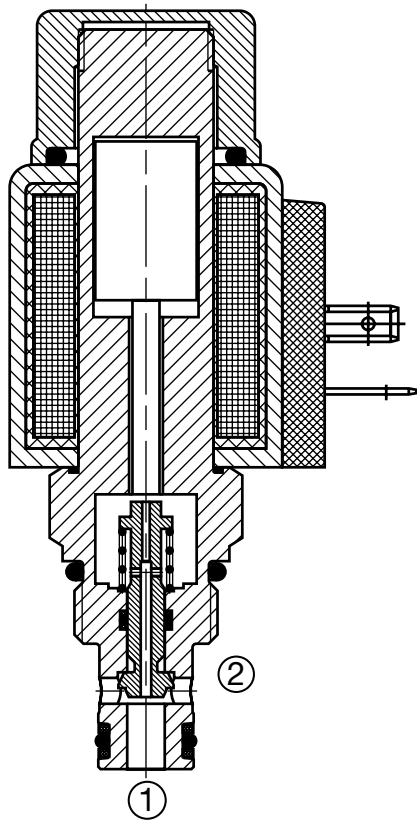
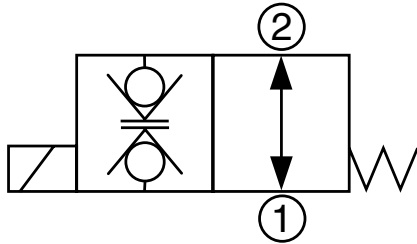

Description

A screw-in cartridge, solenoid operated, 2-way, 2-position, normally open, direct acting, poppet type, intended for use as a bi-directional load holding device in hydraulic circuits requiring low internal leakage.

Operation

When de-energized the WS08V allows flow in both directions. When energized the poppet closes and blocks the flow from port 2 to port 1 and from port 1 to port 2.

Operation of Manual Override Option: To override, push and hold the override button. The override is not detented. The manual override option is intended for emergency use, not for continuous duty operation.

Features

- Push type manual override button, protected by rubber cap

Specifications

Operating Pressure	5000 psi (350 bar)	
Nominal Flow	5 gpm (19 l/min)	
Internal Leakage	Leaktight, less than 2 drops/min. at 3600 psi (0.10 cc/min at 250 bar)	
Fluid Operating Temp. Range	-4° to 248°F (-20° to 120°C) <i>(Consult factory for usage at temp. outside range.)</i>	
Ambient Temperature Range	-4° to 140°F (-20° to 60°C)	
Coil Duty Rating	Continuous from 85% to 115% of nominal voltage	
Current Draw @ 68°F (20°C)	1.5 A at 12VDC; 0.8 A at 24VDC	
Min. Pull-in Voltage @ 68°F (20°C)	85% of nominal @ 5000 psi (350 bar)	
Response Time (typical)	Energized	35 ms
	De-energized	50 ms
Fluid Compatibility	Mineral-based or synthetics with lubricating properties	
Viscosity	50 to 2000 SUS (7.4 to 420 cSt)	
Filtration	21/19/16 or cleaner (per ISO 4406). Use with filter rated $\beta_{10} \geq 200$.	
Installation	No orientation restrictions	
Cavity	FC08-2 (see <i>Line Bodies & Cavities</i> section)	
Cavity Tools	Rougher:	02580090
	Finisher:	02580091
Cartridge Weight	0.31 Lbs. (0.14 kg)	
Coil Weight	0.42 Lbs. (0.19 kg)	
Cartridge Material	Steel with hardened work surfaces. Zinc-plated exposed surfaces. Buna N or Viton® o-rings. PTFE back-up rings.	
Coil Material	Class N high temperature magnet wire, steel shell, polyamid encapsulation.	
Seal Kits	Buna-N	FS082-N P/N: 03033920
	Viton®	FS082-V P/N: 03051756

Performance

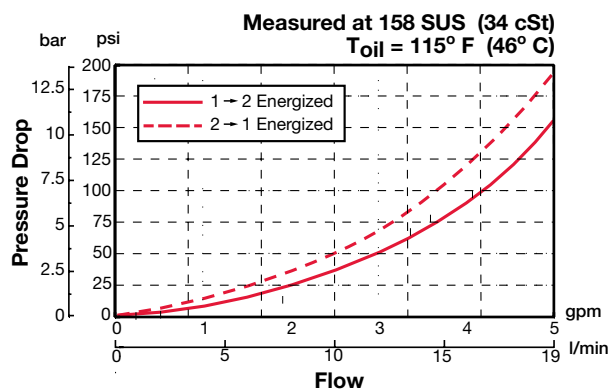

Dimensions

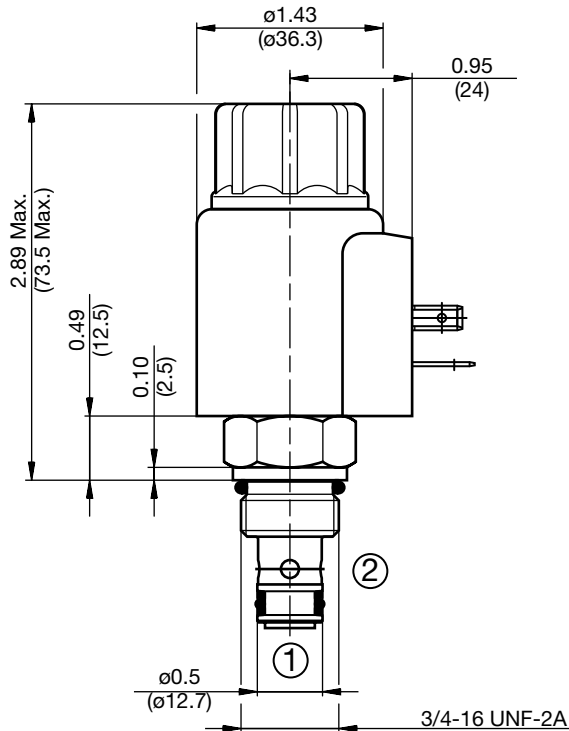
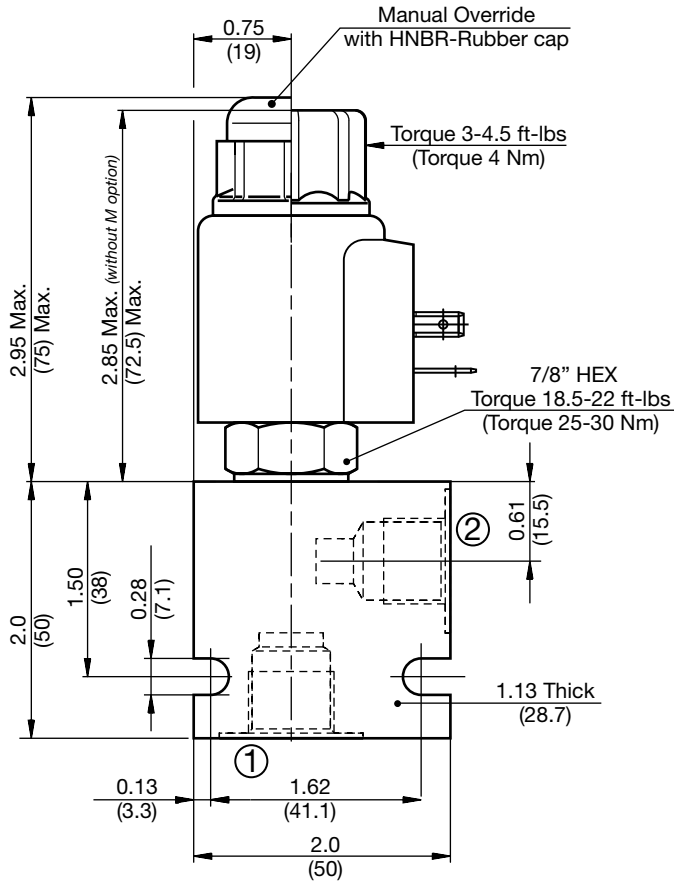

All measurements in inches (mm).
Subject to technical modifications

PN#02087369 / 10.19 / CHD1110-1389

Model Code

WS08V-01 M-C-N-24 DS

Valve Model	WS08V-01
Override Option	M
Body & Ports	C-N
Seals	N
Coil Voltage	24
Coil Connector	DS

- Manual Override with HNBR-Rubber cap**
Torque 3-4.5 ft-lbs (Torque 4 Nm)
- 7/8" HEX**
Torque 18.5-22 ft-lbs (Torque 25-30 Nm)
- Seals**
N = Buna-N
V = Viton®
- Coil Voltage**
0 = No coil, cartridge only
DC 12 = 12 VDC
24 = 24 VDC
36 = 36 VDC
110 = 110 VDC (only available with connector DG)
- Coil Connector**
DC DG = EN 175301-803-A
DS = Dual spade (SAEJ858a)*
DL = Leadwires (2) - 18" long (46 cm)*
DW = WeatherPak™ on leadwires - 9.5" long (24 cm)*
DN = Deutsch™ DT04-2P, molded, axial (IP69K Rated)*
DT = Amp Junior Timer™, molded, radial mount*
- AC AG = EN 175301-803-A

Coil Model 40-1836

For other coil connector types consult factory

*Coils with internal diode are available, consult factory.

Standard Line Bodies*

Code	Part No	Material	Pressure Rating	Weight
FH082-AS6	03011409	Aluminum, anodized	3500 psi (245 bar)	0.34 lbs (0.15 kg)
FH082-SS6	00560917	Steel, Zinc plated	6000 psi (420 bar)	1.0 lbs (0.45 kg)

*Please refer to Line Bodies & Cavities section for details

SOLENOID VALVES

WS08W-01

Poppet Type, Bi-directional, Normally Closed, Direct Acting

Up to 5 gpm (19 l/min) • 3600 psi (250 bar)

Hydraulic Symbol

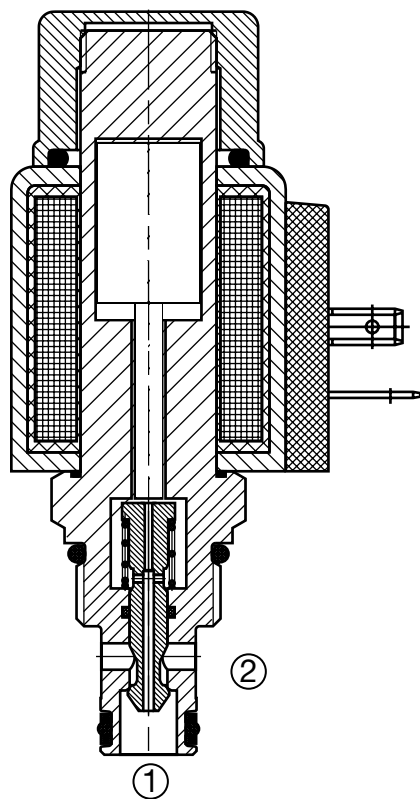
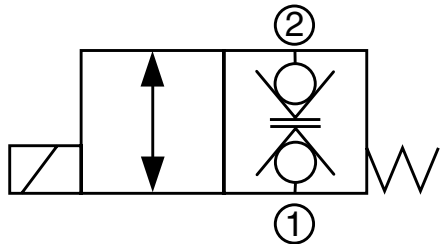

Description

A screw-in cartridge, solenoid operated, 2-way, 2 position, normally closed, direct acting, poppet type, intended for use as a bi-directional load holding device in hydraulic circuits requiring low internal leakage.

Operation

When de-energized the WS08W blocks flow, leakfree, in both directions. When energized the poppet lifts and opens the flow from port 2 to port 1 and from port 1 to port 2.

Operation of Manual Override Option: To override, push and hold the override button. The override is not detented. The manual override option is intended for emergency use, not for continuous duty operation.

Features

- One piece cartridge body design to maximize reliability
- Push type manual override button, protected by rubber cap

Specifications

Operating Pressure	3600 psi (250 bar)	
Nominal Flow	5 gpm (19 l/min)	
Internal Leakage	Leaktight, less than 2 drops/min. at 3600 psi (0.10 cc/min at 250 bar)	
Fluid Operating Temp. Range	-4° to 248°F (-20° to 120°C) <i>(Consult factory for usage at temp. outside range.)</i>	
Ambient Temperature Range	-4° to 140°F (-20° to 60°C)	
Coil Duty Rating	Continuous from 85% to 115% of nominal voltage	
Current Draw @ 68°F (20°C)	1.5 A at 12VDC; 0.8 A at 24VDC	
Min. Pull-in Voltage @ 68°F (20°C)	85% of nominal @ 5000 psi (350 bar)	
Response Time (typical)	Energized	35 ms
	De-energized	50 ms
Fluid Compatibility	Mineral-based or synthetics with lubricating properties	
Viscosity	50 to 2000 SUS (7.4 to 420 cSt)	
Filtration	21/19/16 or cleaner (per ISO 4406). Use with filter rated $\beta_{10} \geq 200$.	
Installation	No orientation restrictions	
Cavity	FC08-2 (see <i>Line Bodies & Cavities</i> section)	
Cavity Tools	Rougher:	02580090
	Finisher:	02580091
Cartridge Weight	0.31 Lbs. (0.14 kg)	
Coil Weight	0.42 Lbs. (0.19 kg)	
Cartridge Material	Steel with hardened work surfaces. Zinc-plated exposed surfaces. Buna N or Viton® o-rings. PTFE back-up rings.	
Coil Material	Class N high temperature magnet wire, steel shell, polyamid encapsulation.	
Seal Kits	Buna-N	FS082-N P/N: 03033920
	Viton®	FS082-V P/N: 03051756

Performance

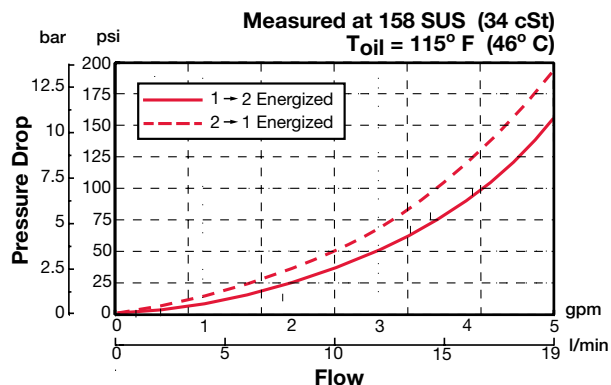

Dimensions

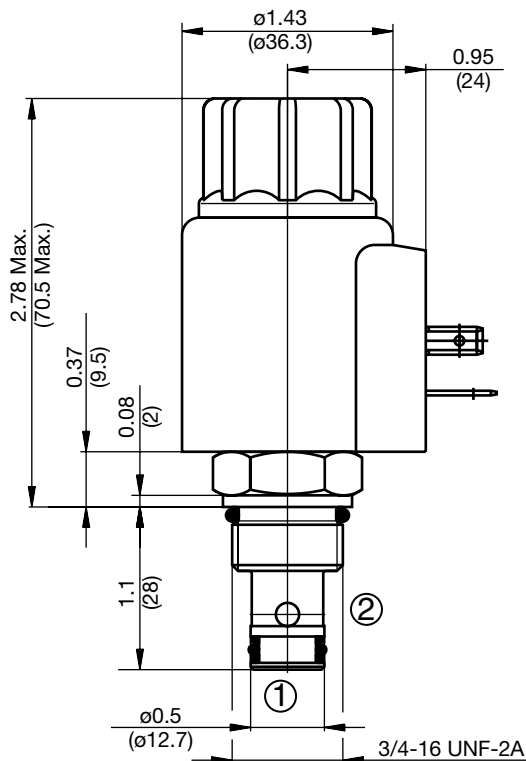
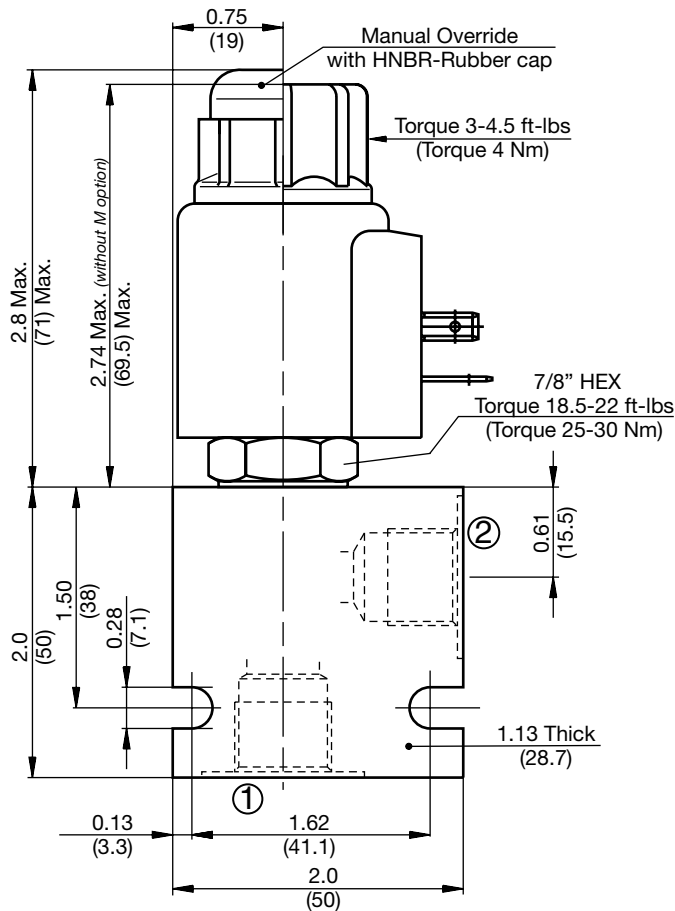

All measurements in inches (mm).
Subject to technical modifications

Model Code

WS08W-01 M-C-N-24 DS

- Valve Model** _____
- Override Option** _____
 blank = No manual override
 M = Manual override, push type
- Body & Ports** _____
 C = Cartridge only
 AS6 = SAE-6 Ports, aluminum body
 SS6 = SAE-6 Ports, steel body
- Seals** _____
 N = Buna-N
 V = Viton®
- Coil Voltage** _____
 0 = No coil, cartridge only
- DC** _____
 12 = 12 VDC
 24 = 24 VDC
 36 = 36 VDC
 110 = 110 VDC (only available with connector DG)
- AC** _____
 24 = 24 VAC
 115 = 115 VAC (AC coils internally full wave rectified)
 230 = 230 VAC
- Coil Connector** _____
 DC DG = EN 175301-803-A
 DS = Dual spade (SAEJ858a)*
 DL = Leadwires (2) - 18" long (46 cm)*
 DW = WeatherPak™ on leadwires - 9.5" long (24 cm)*
 DN = Deutsch™ DT04-2P, molded, axial (IP69K Rated)*
 DT = Amp Junior Timer™, molded, radial mount*
- AC AG** = EN 175301-803-A

Coil Model 40-1836

For other coil connector types consult factory

*Coils with internal diode are available, consult factory.

Standard Line Bodies*

Code	Part No	Material	Pressure Rating	Weight
FH082-AS6	03011409	Aluminum, anodized	3500 psi (245 bar)	0.34 lbs (0.15 kg)
FH082-SS6	00560917	Steel, Zinc plated	6000 psi (420 bar)	1.0 lbs (0.45 kg)

*Please refer to Line Bodies & Cavities section for details

SOLENOID VALVES

WS10W-01

Poppet Type, Bi-directional, Normally Closed, Direct Acting

Up to 10.5 gpm (40 l/min) • 5000 psi (350 bar)

Hydraulic Symbol

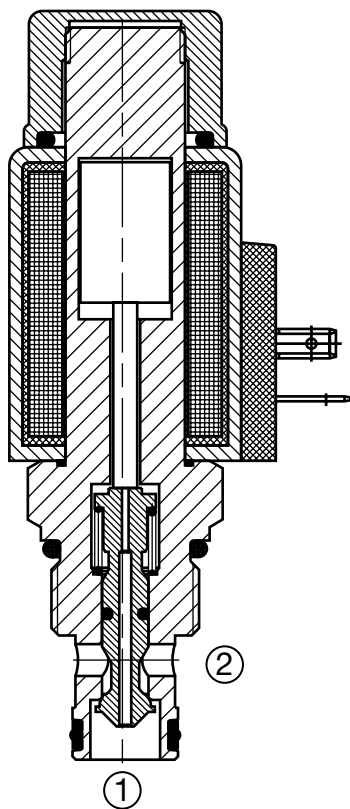
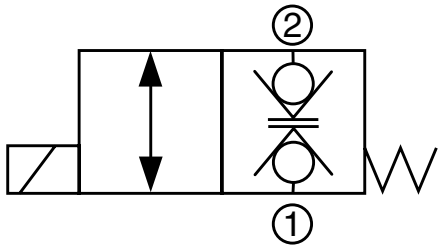

Description

A screw-in cartridge, solenoid operated, 2-way, 2 position, normally closed, direct acting, poppet type, intended for use as a bi-directional load holding device in hydraulic circuits requiring low internal leakage.

Operation

When de-energized the WS10W blocks flow, leakfree, in both directions. When energized the poppet lifts and opens the flow from port 2 to port 1 and from port 1 to port 2.

Operation of Manual Override Option: To override, push and hold the override button. The override is not detented. The manual override option is intended for emergency use, not for continuous duty operation.

Features

- One piece cartridge body design to maximize reliability
- Push type manual override button, protected by rubber cap

Specifications

Operating Pressure	5000 psi (350 bar)
Nominal Flow	10.5 gpm (40 l/min)
Internal Leakage	Leaktight, less than 5 drops/min. at 5000 psi (0.25 cc/min at 350 bar)
Fluid Operating Temp. Range	-4° to 248°F (-20° to 120°C) <i>(Consult factory for usage at temp. outside range.)</i>
Ambient Temperature Range	-4° to 140°F (-20° to 60°C)
Coil Duty Rating	Continuous from 85% to 115% of nominal voltage
Current Draw @ 68°F (20°C)	2.22 A at 12VDC; 1.13 A at 24VDC
Min. Pull-in Voltage @ 68°F (20°C)	85% of nominal @ 5000 psi (350 bar)
Response Time (typical)	Energized 35 ms De-energized 50 ms
Fluid Compatibility	Mineral-based or synthetics with lubricating properties
Viscosity	50 to 2000 SUS (7.4 to 420 cSt)
Filtration	21/19/16 or cleaner (per ISO 4406). Use with filter rated $\beta_{10} \geq 200$.
Installation	No orientation restrictions
Cavity	FC10-2 (see <i>Line Bodies & Cavities</i> section)
Cavity Tools	Rougher: 02580274 Finisher: 02580247
Cartridge Weight	0.40 Lbs. (0.18 kg)
Coil Weight	0.51 Lbs. (0.23 kg)
Cartridge Material	Steel with hardened work surfaces. Zinc-plated exposed surfaces. Buna N or Viton® o-rings. PTFE back-up rings.
Coil Material	Class N high temperature magnet wire, steel shell, polyamid encapsulation.
Seal Kits	Buna-N FS102-N P/N: 03033872 Viton® FS102-V P/N: 03051757

Performance

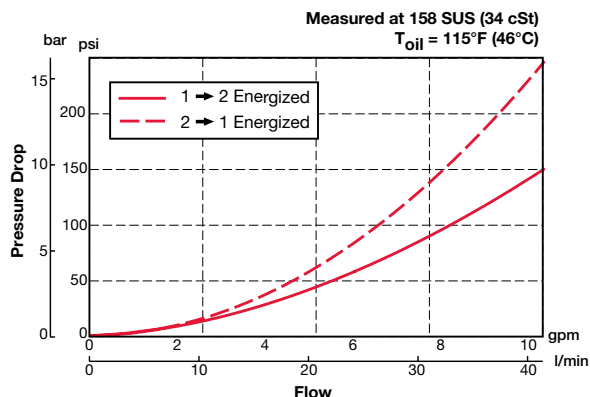

Dimensions

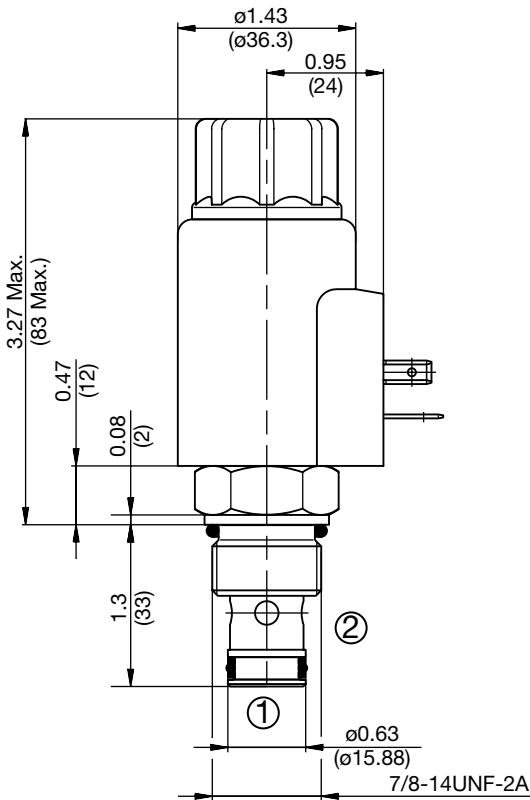
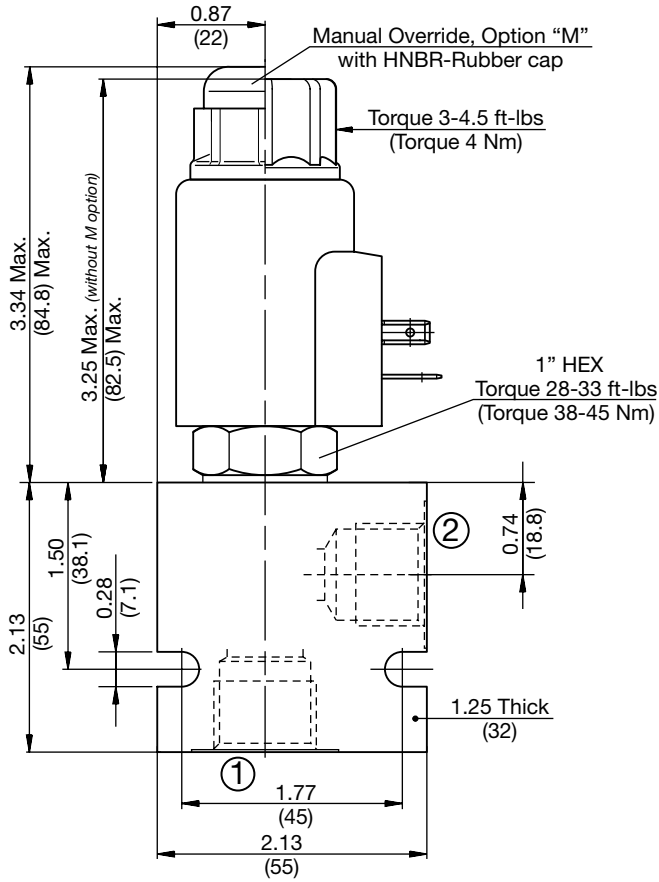

All measurements in inches (mm).
Subject to technical modifications

Model Code

WS10W-01 M-C-N-24 DS

Valve Model	WS10W-01
Override Option	M
Body & Ports	C-N
Coil Voltage	24
Coil Connector	DS

blank = No manual override
M = Manual override, push type

C = Cartridge only
AS8 = SAE-8 Ports, aluminum body
SS8 = SAE-8 Ports, steel body

N = Buna-N
V = Viton®

0 = No coil, cartridge only
DC 12 = 12 VDC
24 = 24 VDC
36 = 36 VDC
110 = 110 VDC (only available with connector DG)
AC 24 = 24 VAC
115 = 115 VAC (AC coils internally full wave rectified)
230 = 230 VAC

DC DG = EN 175301-803-A
DS = Dual spade (SAEJ858a)*
DL = Leadwires (2) - 18" long (46 cm)*
DW = WeatherPak™ on leadwires - 9.5" long (24 cm)*
DN = Deutsch™ DT04-2P, molded, axial (IP69K Rated)*
DT = Amp Junior Timer™, molded, radial mount*

AC AG = EN 175301-803-A

Coil Model 50-1836

For other coil connector types consult factory

*Coils with internal diode are available, consult factory.

Standard Line Bodies*

Code	Part No	Material	Pressure Rating	Weight
FH102-AS8	03037778	Aluminum, anodized	3500 psi (245 bar)	0.40 lbs (0.18 kg)
FH102-SS8	03037612	Steel, Zinc plated	6000 psi (420 bar)	1.16 lbs (0.53 kg)

*Please refer to Line Bodies & Cavities section for details

SOLENOID VALVES

WS08W-30

Poppet Type, Bi-directional, Normally Closed, Direct Acting

Up to 5 gpm (19 l/min) • 3600 psi (250 bar)

Hydraulic Symbol

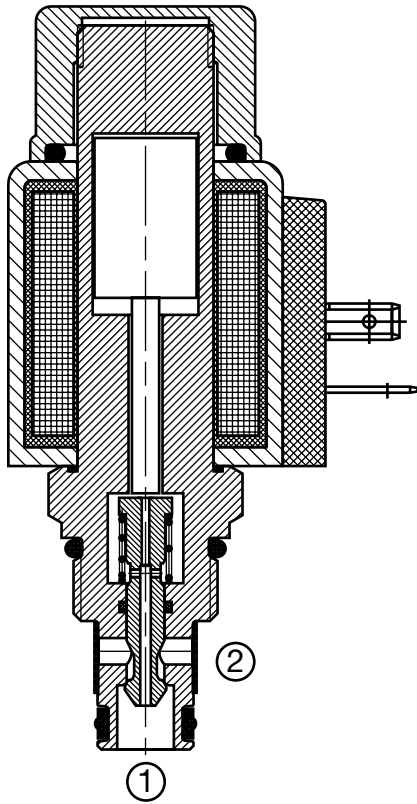
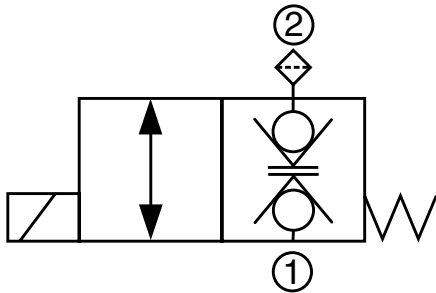

Description

A screw-in cartridge, solenoid operated, 2-way, 2 position, normally closed, direct acting, poppet type, with filter screen on port 2, intended for use as a bi-directional load holding device in hydraulic circuits requiring low internal leakage.

Operation

When de-energized the WS08W blocks flow, leakfree, in both directions. When energized the poppet lifts and opens the flow from port 2 to port 1 and from port 1 to port 2.

Operation of Manual Override Option: To override, push and hold the override button. The override is not detented. The manual override option is intended for emergency use, not for continuous duty operation.

Features

- Filter screen on port 2 for protection from contamination getting inside the cartridge
- One piece cartridge body design to maximize reliability
- Push type manual override button, protected by rubber cap

Specifications

Operating Pressure	3600 psi (250 bar)
Nominal Flow	5 gpm (19 l/min)
Internal Leakage	Leaktight, less than 2 drops/min. at 3600 psi (0.10 cc/min at 250 bar)
Fluid Operating Temp. Range	-4° to 248°F (-20° to 120°C) (Consult factory for usage at temp. outside range.)
Ambient Temperature Range	-4° to 140°F (-20° to +60°C)
Coil Duty Rating	Continuous from 85% to 115% of nominal voltage
Current Draw @ 68°F (20°C)	1.5 A at 12VDC; 0.8 A at 24VDC
Min. Pull-in Voltage @ 68°F (20°C)	85% of nominal @ 5000 psi (350 bar)
Response Time (typical)	Energized 35 ms De-energized 50 ms
Fluid Compatibility	Mineral-based or synthetics with lubricating properties
Viscosity	50 to 2000 SUS (7.4 to 420 cSt)
Filtration	21/19/16 or cleaner (per ISO 4406). Use with filter rated $\beta_{10} \geq 200$.
Filter screen	300 μ m mesh
Installation	No orientation restrictions
Cavity	FC08-2 (see Line Bodies & Cavities section)
Cavity Tools	Rougher: 02580090 Finisher: 02580091
Cartridge Weight	0.31 Lbs. (0.14 kg)
Coil Weight	0.42 Lbs. (0.19 kg)
Cartridge Material	Steel with hardened work surfaces. Zinc-plated exposed surfaces. Buna N or Viton® o-rings. PTFE back-up rings.
Coil Material	Class N high temperature magnet wire, steel shell, polyamid encapsulation.
Seal Kits	Buna-N FS082-N P/N: 03033920 Viton® FS082-V P/N: 03051756

Performance

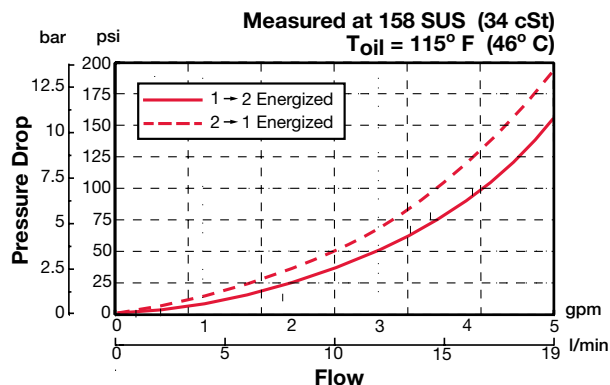

Dimensions

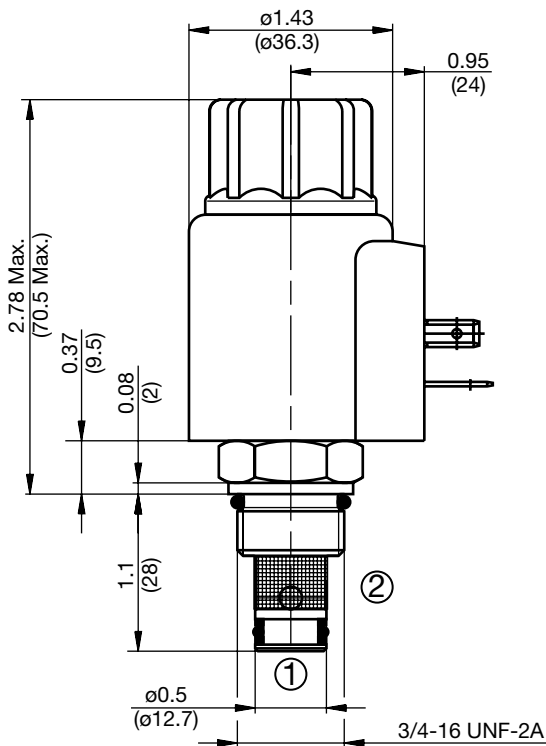
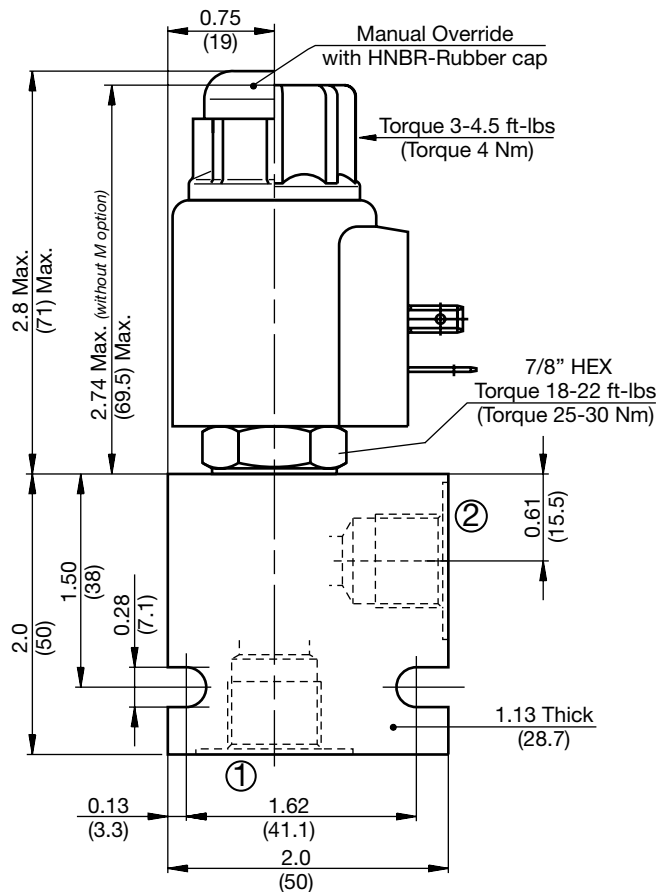

All measurements in inches (mm).
Subject to technical modifications

Model Code

WS08W-30 M-C-N-24 DS

- Valve Model** _____
- Override Option** _____
 blank = No manual override
 M = Manual override, push type
- Body & Ports** _____
 C = Cartridge only
 AS6 = SAE-6 Ports, aluminum body
 SS6 = SAE-6 Ports, steel body
- Seals** _____
 N = Buna-N
 V = Viton®
- Coil Voltage** _____
 0 = No coil, cartridge only
- DC** _____
 12 = 12 VDC
 24 = 24 VDC
 36 = 36 VDC
 110 = 110 VDC (only available with connector DG)
- AC** _____
 24 = 24 VAC
 115 = 115 VAC (AC coils internally full wave rectified)
 230 = 230 VAC
- Coil Connector** _____
 DC DG = EN 175301-803-A
 DS = Dual spade (SAEJ858a)*
 DL = Leadwires (2) - 18" long (46 cm)*
 DW = WeatherPak™ on leadwires - 9.5" long (24 cm)*
 DN = Deutsch™ DT04-2P, molded, axial (IP69K Rated)*
 DT = Amp Junior Timer™, molded, radial mount*
- AC AG** = EN 175301-803-A

Coil Model 40-1836

For other coil connector types consult factory

*Coils with internal diode are available, consult factory.

Standard Line Bodies*

Code	Part No	Material	Pressure Rating	Weight
FH082-AS6	03011409	Aluminum, anodized	3500 psi (245 bar)	0.34 lbs (0.15 kg)
FH082-SS6	00560917	Steel, Zinc plated	6000 psi (420 bar)	1.0 lbs (0.45 kg)

*Please refer to Line Bodies & Cavities section for details

SOLENOID VALVES

WS08D-51

Poppet Type, Normally Closed, Direct Acting

Up to 5 gpm (19 l/min) • 4000 psi (280 bar)

Hydraulic Symbol

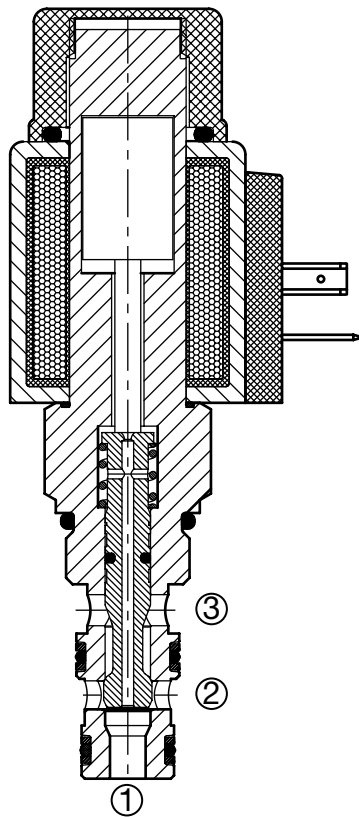
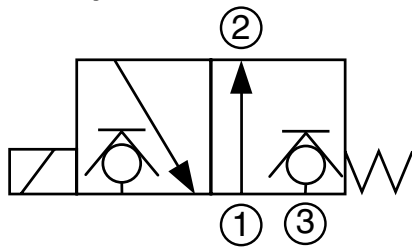

Description

A screw-in cartridge, solenoid operated, 3-way, 2 position, normally closed, direct acting, poppet type, intended for use as a directional control and load holding device in hydraulic circuits requiring low internal leakage.

Operation

When de-energized the WS08W-51 blocks flow, leakfree at port 3 and allows flow from port 1 to port 2. When energized, flow is blocked at port 1 and allowed from port 2 to port 3.

Operation of Manual Override Option: To override, push and hold the override button. The override is not detented. The manual override option is intended for emergency use, not for continuous duty operation.

Features

- Push type manual override button, protected by rubber cap

Specifications

Operating Pressure	4000 psi (280 bar)	
Nominal Flow	5 gpm (19 l/min)	
Internal Leakage	Leaktight, less than 5 drops/min. at 4000 psi (0.25 cc/min at 280 bar)	
Fluid Operating Temp. Range	-4° to 248°F (-20° to 120°C) (Consult factory for usage at temp. outside range.)	
Ambient Temperature Range	-4° to 140°F (-20° to 60°C)	
Coil Duty Rating	Continuous from 85% to 115% of nominal voltage	
Current Draw @ 68°F (20°C)	1.5 A at 12VDC; 0.8 A at 24VDC	
Min. Pull-in Voltage @ 68°F (20°C)	85% of nominal @ 5000 psi (350 bar)	
Response Time (typical)	Energized 35 ms	De-energized 45 ms
Fluid Compatibility	Mineral-based or synthetics with lubricating properties	
Viscosity	50 to 2000 SUS (7.4 to 420 cSt)	
Filtration	21/19/16 or cleaner (per ISO 4406). Use with filter rated $\beta_{10} \geq 200$.	
Installation	No orientation restrictions	
Cavity	FC08-3 (see <i>Line Bodies & Cavities</i> section)	
Cavity Tools	Rougher: 02580086	Finisher: 02580087
Cartridge Weight	0.87 Lbs. (0.39 kg)	
Coil Weight	0.42 Lbs. (0.19 kg)	
Cartridge Material	Steel with hardened work surfaces. Zinc-plated exposed surfaces. Buna N or Viton® o-rings. PTFE back-up rings.	
Coil Material	Class N high temperature magnet wire, steel shell, polyamid encapsulation.	
Seal Kits	Buna-N	FS083-N P/N: 03054795
	Viton®	FS082-V P/N: 02591059

Performance

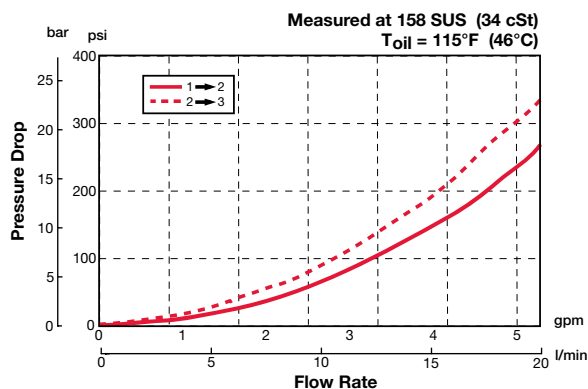

Dimensions

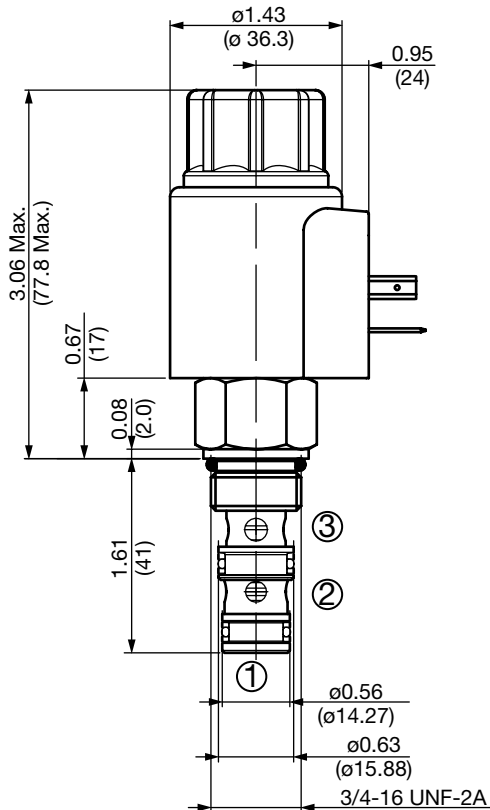
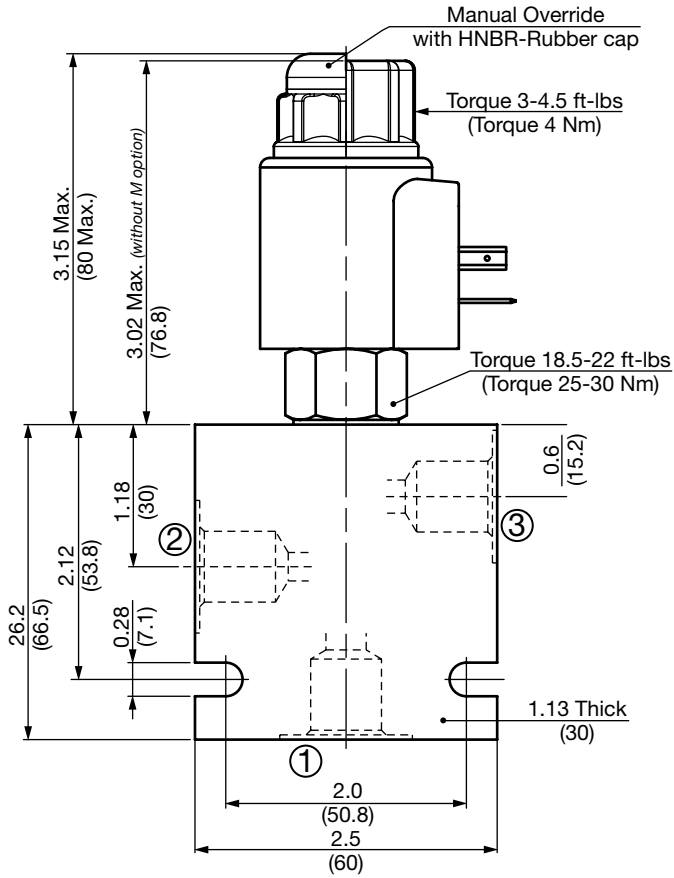

Model Code

WS08D-51 M-C-N-24 DS

Valve Model

Override Option

- blank = No manual override
- M = Manual override, push type

Body & Ports

- C = Cartridge only
- AS6 = SAE-6 Ports, aluminum body
- SS6 = SAE-6 Ports, steel body

Seals

- N = Buna-N
- V = Viton®

Coil Voltage

- 0 = No coil, cartridge only

DC

- 12 = 12 VDC
- 24 = 24 VDC
- 36 = 36 VDC
- 110 = 110 VDC (only available with connector DG)

AC

- 24 = 24 VAC
- 115 = 115 VAC (AC coils internally full wave rectified)
- 230 = 230 VAC

Coil Connector

- DC DG = EN 175301-803-A
- DS = Dual spade (SAEJ858a)*
- DL = Leadwires (2) - 18" long (46 cm)*
- DW = WeatherPak™ on leadwires - 9.5" long (24 cm)*
- DN = Deutsch™ DT04-2P, molded, axial (IP69K Rated)*
- DT = Amp Junior Timer™, molded, radial mount*

- AC AG = EN 175301-803-A

Coil Model 40-1836

For other coil connector types consult factory

*Coils with internal diode are available, consult factory.

Operating Limits

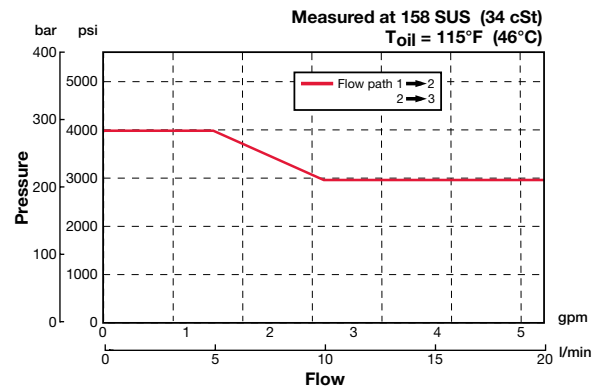

Standard Line Bodies*

Code	Part No	Material	Pressure Rating	Weight
FH083-AS6	03011424	Aluminum, anodized	3500 psi (245 bar)	0.58 lbs (0.15 kg)
FH082-SS6	00560920	Steel, Zinc plated	6000 psi (420 bar)	1.7 lbs (0.45 kg)

*Please refer to Line Bodies & Cavities section for details

Note: Orifice plug not permitted at port 1

All measurements in inches (mm).
Subject to technical modifications

SOLENOID VALVES

WK06V-01

Spool Type, Normally Open, Direct Acting

Up to 4 gpm (15.2 lpm) • 5000 psi (350 bar)

Hydraulic Symbol

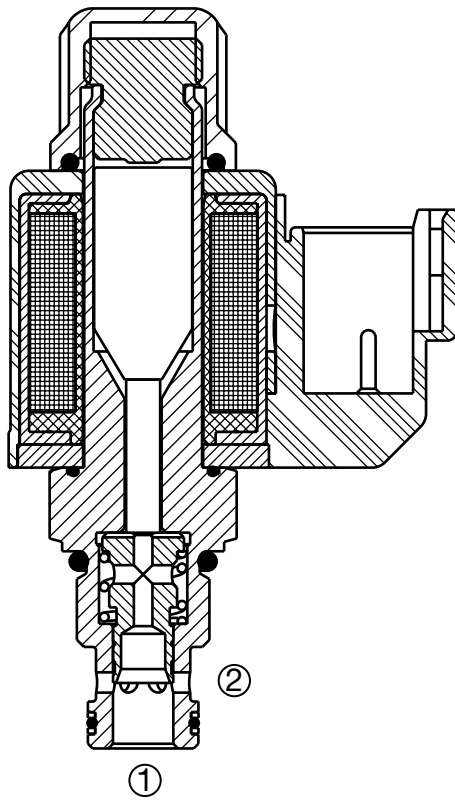
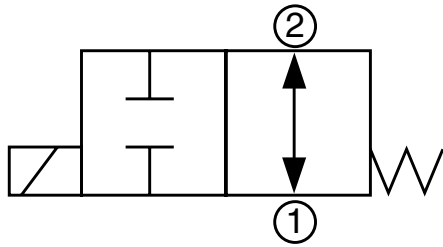

Description

A screw-in cartridge, solenoid operated, 2-way, 2 position, normally open, direct acting, spool type, intended for use as a bi-directional flow blocking valve.

Operation

When de-energized the WK06V allows bi-directional flow. When energized the spool shifts and blocks flow in both directions.

Operation of Manual Override Option: To override, push and hold the override button. The override is not detented. The manual override option is intended for emergency use, not for continuous duty operation.

Features

- Push type manual override button, protected by rubber cap

Specifications

Operating Pressure	5000 psi (350 bar)
Nominal Flow	See Operating Limits
Internal Leakage	5.5 cu in/min at 3600 psi and 135 SUS (90cc/min at 248 bar at 28cSt)
Fluid Operating Temp. Range	-20° to 248°F (-29° to 120°C) (Consult factory for usage at temp. outside range.)
Ambient Temperature Range	-20° to 140°F (-29° to 60°C)
Coil Duty Rating	Continuous from 85% to 115% of nominal voltage
Current Draw @ 68°F (20°C)	984 mA at 12VDC; 492 mA at 24VDC
Min. Pull-in Current to Operate Valve	80% of nominal amperage
Typical Response Time (Varies with Pressure and Flow)	Energized 50ms De-energized 35ms
Fluid Compatibility	Mineral-based or synthetics with lubricating properties
Viscosity	50 to 2000 SUS (7.4 to 420 cSt)
Filtration	21/19/16 or cleaner per (ISO 4406)
Installation	No orientation restrictions
Cavity	FC06-2 (see Line Bodies & Cavities section)
Cavity Tools	Rougher: 02582046 Finisher: 02582047
Cartridge Weight	0.17 lb (0.08 kg)
Coil Weight	0.19 lb (0.09 kg)
Cartridge Material	Steel with hardened work surfaces. Zinc plated exposed surfaces. Buna N or Viton® o-rings. Solid thermoplastic polyester back-up rings.
Coil Material	Class N, 200°C high temperature magnet wire, steel shell, polyester encapsulation.
Seal Kits	Buna-N FS062-N P/N: 02610184 Viton® FS062-V P/N: 02610185

Performance

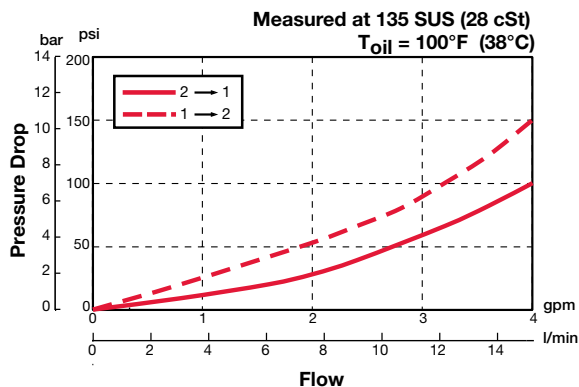

Dimensions

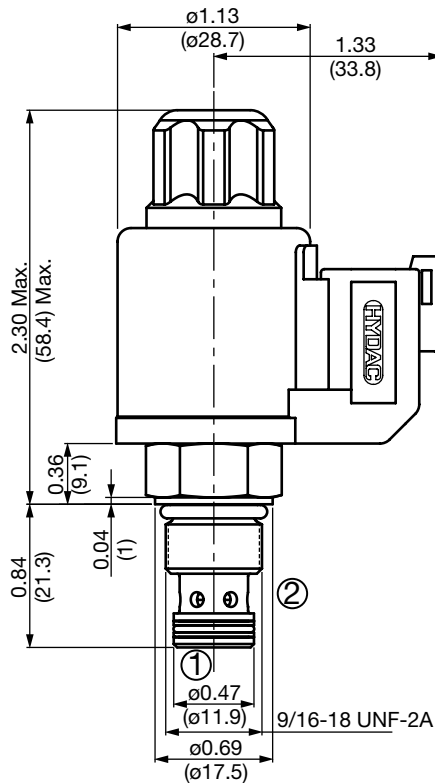
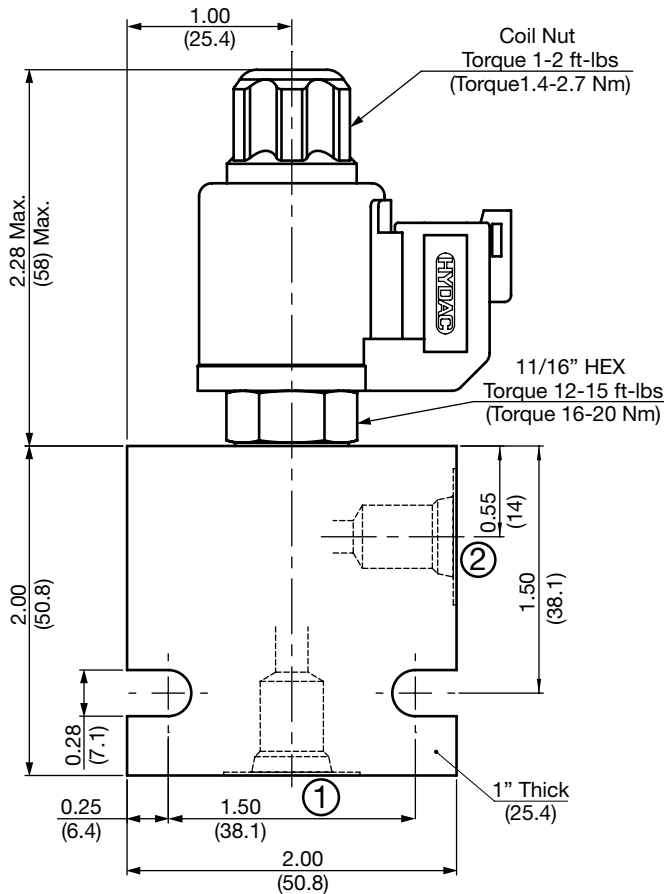

All measurements in inches (mm).
Subject to technical modifications

Model Code

WK06V-01 M-C-N-24 DN

Valve Model

Override Option

blank = No manual override
M = Manual override, push type

Body & Ports

C = Cartridge only
AS4 = SAE-4 Ports, aluminum body
SS4 = SAE-4 Ports, steel body

Seals

N = Buna-N
V = Viton®

Coil Voltage

0 = No coil, cartridge only

DC 12 = 12 VDC
24 = 24 VDC

AC 115 = 105 VAC (only available with connector DG)

230 = 205 VAC (only available with connector DG)

(All model 32-1329 coils are DC. AC models require an external diode bridge mounted outside the coil)**

Coil Connector

DC DG = DIN 43650 Form B (IP65 Rated)**

DL = Leadwires (2) 18" long (46 cm) AWG18, TYPE UL 1815 (IP69K Rated)*

DN = Deutsch DT04-2P integral molded (IP69K Rated)*

Use mating plug DIN 43650 form B without diode bridge for DC voltages P/N 02600570

Use mating plug DIN 43650 form B w/diode bridge for AC voltages P/N 02600582

Coil Model 32-1329

For other coil connector types consult factory

**Mating Plugs sold separately

*Coils with internal Transient Suppression diode are available, consult factory.

Operating Limits

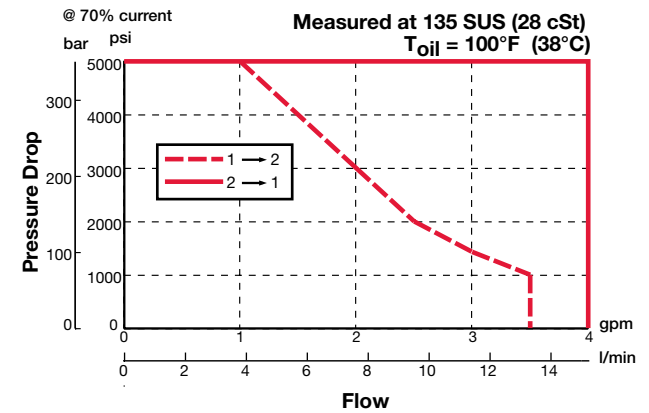

Standard Line Bodies*

Code	Part No	Material	Pressure Rating	Weight
FH062-AS4	02600491	Aluminum, anodized	3500 psi (245 bar)	0.34 lbs (0.15 kg)
FH062-SS4	02600490	Steel, zinc plated	6000 psi (420 bar)	1.0 lbs (0.45 kg)

*Please refer to Line Bodies & Cavities section for details

SOLENOID VALVES

WK08V-01

Spool Type, Normally Open, Direct Acting

Up to 5 gpm (19 l/min) • 5000 psi (350 bar)

Hydraulic Symbol

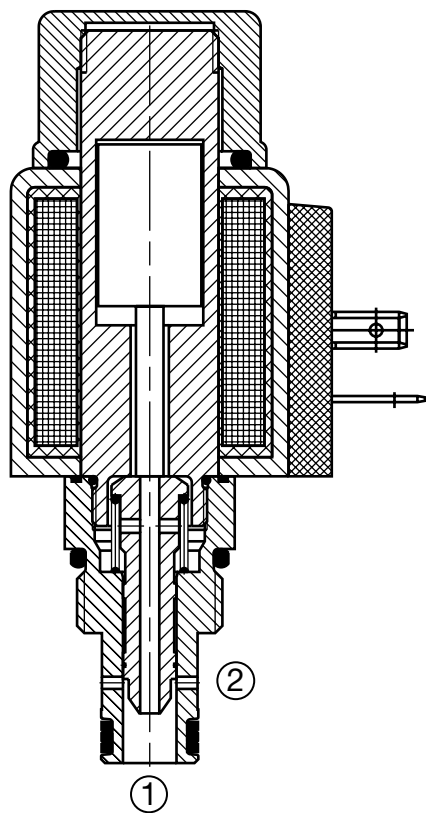
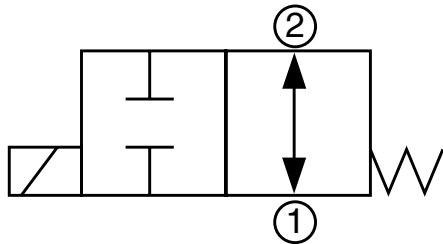

Description

A screw-in cartridge, solenoid operated, 2-way, 2 position, normally open, direct acting, spool type, intended for use as a bi-directional flow blocking valve.

Operation

When de-energized the WK08V allows bi-directional flow. When energized the spool shifts and blocks flow in both directions.

Operation of Manual Override Option: To override, push and hold the override button. The override is not detented. The manual override option is intended for emergency use, not for continuous duty operation.

Features

- Push type manual override button, protected by rubber cap

Specifications

Operating Pressure	5000 psi (350 bar)
Nominal Flow	5 gpm (19 l/min)
Internal Leakage	5.5 cu in/min. at 3000 psi and 158 SUS (90 cc/min at 210 bar and 34 cSt)
Fluid Operating Temp. Range	-4° to 248°F (-20° to 120°C) <i>(Consult factory for usage at temp. outside range.)</i>
Ambient Temperature Range	-4° to 140°F (-20° to 60°C)
Coil Duty Rating	Continuous from 85% to 115% of nominal voltage
Current Draw @ 68°F (20°C)	1.5 A at 12VDC; 0.8 A at 24VDC
Min. Pull-in Voltage @ 68°F (20°C)	85% of nominal @ 5000 psi (350 bar)
Fluid Compatibility	Mineral-based or synthetics with lubricating properties
Viscosity	50 to 2000 SUS (7.4 to 420 cSt)
Filtration	21/19/16 or cleaner (per ISO 4406). Use with filter rated $\beta_{10} \geq 200$.
Installation	No orientation restrictions
Cavity	FC08-2 (see <i>Line Bodies & Cavities</i> section)
Cavity Tools	Rougher: 02580090 Finisher: 02580091
Cartridge Weight	0.38 Lbs. (0.17 kg)
Coil Weight	0.42 Lbs. (0.19 kg)
Cartridge Material	Steel with hardened work surfaces. Zinc-plated exposed surfaces. Buna N or Viton® o-rings. PTFE back-up rings.
Coil Material	Class N high temperature magnet wire, steel shell, polyamid encapsulation.
Seal Kits	Buna-N Viton®
	FS082-N P/N: 03033920 FS082-V P/N: 03051756

Performance

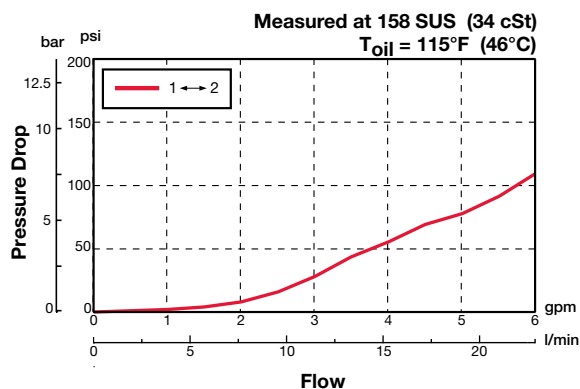

Dimensions

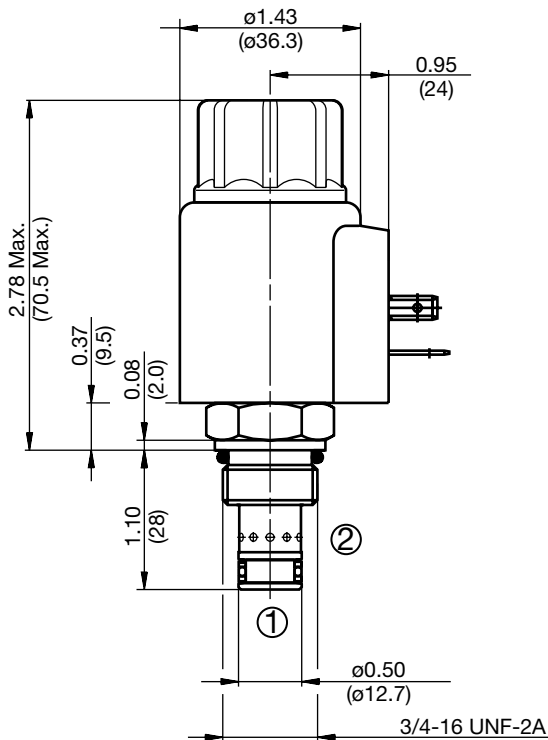
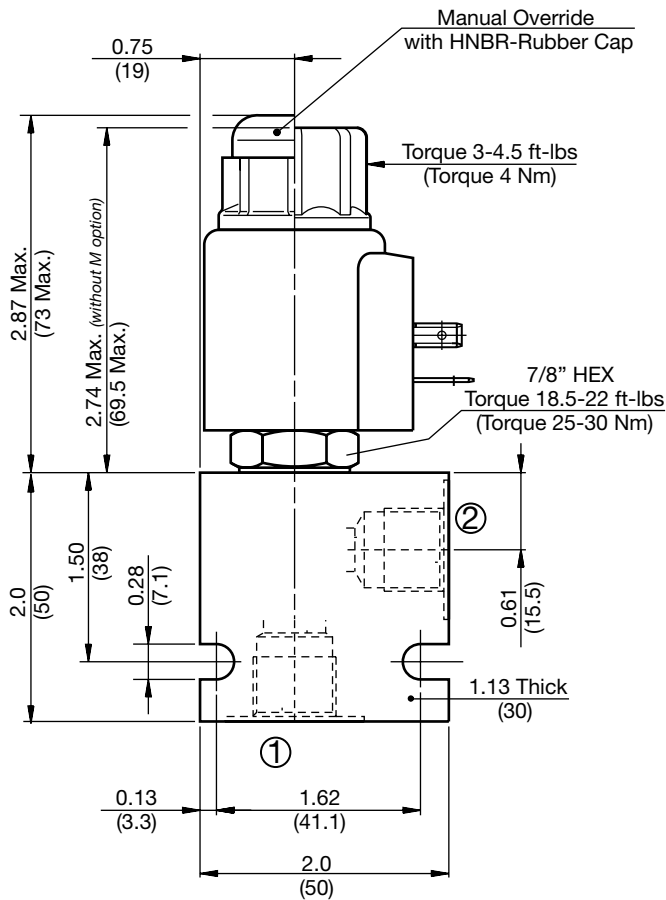

All measurements in inches (mm).
Subject to technical modifications

Model Code

WK08V-01 M-C-N-24 DN

Valve Model

Override Option

- blank = No manual override
- M = Manual override, push type

Body & Ports

- C = Cartridge only
- AS6 = SAE-6 Ports, aluminum body
- SS6 = SAE-6 Ports, steel body

Seals

- N = Buna-N
- V = Viton®

Coil Voltage

- 0 = No coil, cartridge only

DC

- 12 = 12 VDC
- 24 = 24 VDC
- 36 = 36 VDC
- 110 = 110 VDC (only available with connector DG)

AC

- 24 = 24 VAC
- 115 = 115 VAC (AC coils internally full wave rectified)
- 230 = 230 VAC

Coil Connector

- DC DG = EN 175301-803-A
- DS = Dual spade (SAEJ858a)*
- DL = Leadwires (2) - 18" long (46 cm)*
- DW = WeatherPak™ on leadwires - 9.5" long (24 cm)*
- DN = Deutsch™ DT04-2P, molded, axial (IP69K Rated)*
- DT = Amp Junior Timer™, molded, radial mount*

- AC AG = EN 175301-803-A

Coil Model 40-1836

For other coil connector types consult factory

*Coils with internal diode are available, consult factory.

Standard Line Bodies*

Code	Part No	Material	Pressure Rating	Weight
FH082-AS6	03011409	Aluminum, anodized	3500 psi (245 bar)	0.34 lbs (0.15 kg)
FH082-SS6	00560917	Steel, Zinc plated	6000 psi (420 bar)	1.0 lbs (0.45 kg)

*Please refer to Line Bodies & Cavities section for details

SOLENOID VALVES

WK10V-01

Spool Type, Normally Open, Direct Acting

Up to 9 gpm (35 l/min) • 5000 psi (350 bar)

Hydraulic Symbol

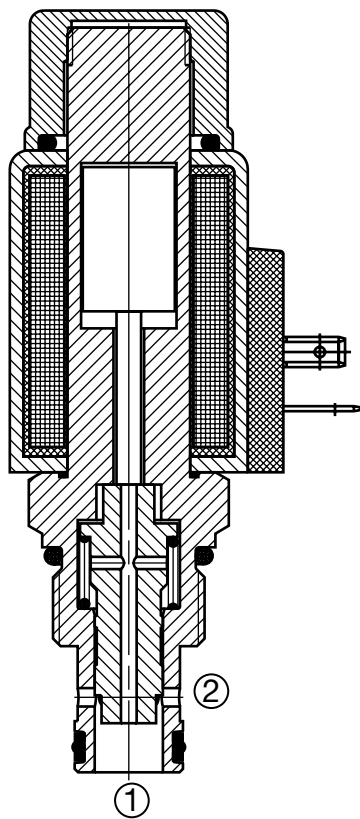
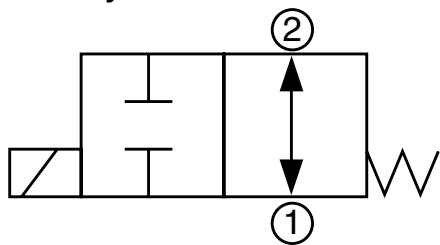

Description

A screw-in cartridge, solenoid operated, 2-way, 2 position, normally open, direct acting, spool type, intended for use as a bi-directional flow blocking valve.

Operation

When de-energized the WK10V allows bi-directional flow. When energized the spool shifts and blocks flow in both directions.

Operation of Manual Override Option: To override, push and hold the override button. The override is not detented. The manual override option is intended for emergency use, not for continuous duty operation.

Features

- Push type manual override button, protected by rubber cap

Specifications

Operating Pressure	5000 psi (350 bar)
Nominal Flow	9 gpm (35 l/min)
Internal Leakage	7.3 cu in/min. at 3600 psi and 158 SUS (120 cc/min at 250 bar and 34 cSt)
Fluid Operating Temp. Range	-4° to 248°F (-20° to 120°C) <i>(Consult factory for usage at temp. outside range.)</i>
Ambient Temperature Range	-4° to 140°F (-20° to 60°C)
Coil Duty Rating	Continuous from 85% to 115% of nominal voltage
Current Draw @ 68°F (20°C)	2.22 A at 12VDC; 1.13 A at 24VDC
Min. Pull-in Voltage @ 68°F (20°C)	85% of nominal @ 5000 psi (350 bar)
Fluid Compatibility	Mineral-based or synthetics with lubricating properties
Viscosity	50 to 2000 SUS (7.4 to 420 cSt)
Filtration	21/19/16 or cleaner (per ISO 4406). Use with filter rated $\beta_{10} \geq 200$.
Installation	No orientation restrictions
Cavity	FC10-2 (see <i>Line Bodies & Cavities</i> section)
Cavity Tools	Rougher: 02580274 Finisher: 02580247
Cartridge Weight	0.48 Lbs. (0.22 kg)
Coil Weight	0.51 Lbs. (0.23 kg)
Cartridge Material	Steel with hardened work surfaces. Zinc-plated exposed surfaces. Buna N or Viton® o-rings. PTFE back-up rings.
Coil Material	Class N high temperature magnet wire, steel shell, polyamid encapsulation.
Seal Kits	Buna-N FS102-N P/N: 03033872 Viton® FS102-V P/N: 03051757

Performance

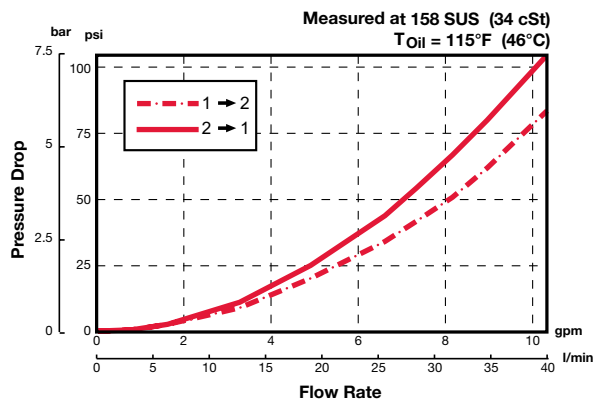

Dimensions

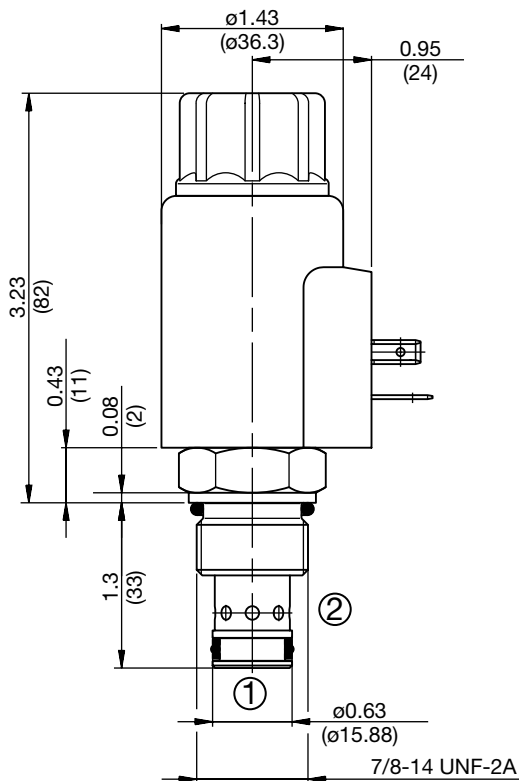
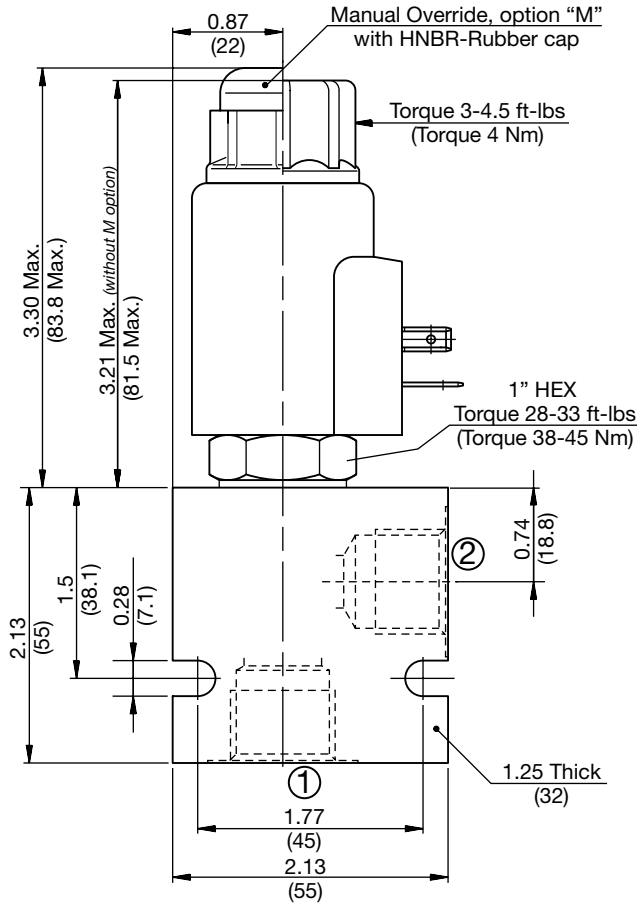

All measurements in inches (mm).
Subject to technical modifications

Model Code

WK10V-01 M-C-N-24 DN

Valve Model

Override Option

blank = No manual override
M = Manual override, push type

Body & Ports

C = Cartridge only
AS8 = SAE-8 Ports, aluminum body
SS8 = SAE-8 Ports, steel body

Seals

N = Buna-N
V = Viton®

Coil Voltage

0 = No coil, cartridge only

DC

12 = 12 VDC
24 = 24 VDC
36 = 36 VDC
110 = 110 VDC (only available with connector DG)

AC

24 = 24 VAC
115 = 115 VAC (AC coils internally full wave rectified)
230 = 230 VAC

Coil Connector

DC

DG = EN 175301-803-A
DS = Dual spade (SAEJ858a)*
DL = Leadwires (2) - 18" long (46 cm)*
DW = WeatherPak™ on leadwires - 9.5" long (24 cm)*
DN = Deutsch™ DT04-2P, molded, axial (IP69K Rated)*
DT = Amp Junior Timer™, molded, radial mount*

AC

AG = EN 175301-803-A

Coil Model 50-1836

For other coil connector types consult factory

*Coils with internal diode are available, consult factory.

Standard Line Bodies*

Code	Part No	Material	Pressure Rating	Weight
FH102-AS8	03037778	Aluminum, anodized	3500 psi (245 bar)	0.40 lbs (0.18 kg)
FH102-SS8	03037612	Steel, Zinc plated	6000 psi (420 bar)	1.16 lbs (0.53 kg)

*Please refer to Line Bodies & Cavities section for details

SOLENOID VALVES

WK06W-01

Spool Type, Normally Closed, Direct Acting

Up to 2.5 gpm (9.5 l/min) • 5000 psi (350 bar)

Hydraulic Symbol

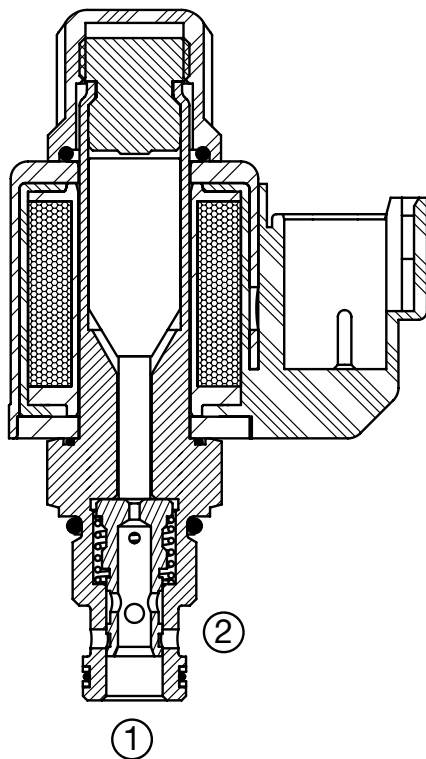
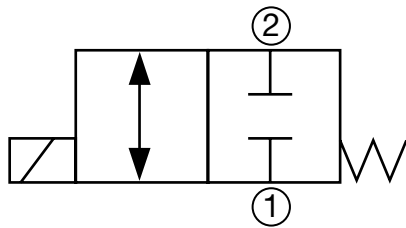

Description

A screw-in cartridge, solenoid operated, 2-way, 2 position, direct acting, spool type valve.

Operation

When de-energized the WK06W blocks flow in both directions. When energized the spool shifts and opens the bidirectional flow path.

Specifications

Operating Pressure	5000 psi (350 bar)
Nominal Flow	2.5 gpm (9.5 l/min)
Internal Leakage	5.5 cu in/min. at 3000 psi and 135 SUS (90 cc/min at 207 bar and 28 cSt)
Fluid Operating Temp. Range	-20° to 248°F (-29° to 120°C)
Ambient Temperature Range	-20° to 140°F (-29° to 60°C)
Coil Duty Rating	Continuous from 85% to 115% of nominal voltage
Current Draw at 68°F (20°C)	984 mA at 12VDC; 492 mA at 24VDC
Min. Pull-in Current to Operate Valve	70% of nominal amperage
Fluid Compatibility	Mineral-Based or Synthetics with lubricating properties
Viscosity	50 to 2000 SUS (7.4 to 420 cSt)
Filtration	21/19/16 or cleaner per (ISO 4406)
Installation	No orientation restrictions
Cavity	FC06-2 (see <i>Line Bodies & Cavities</i> section)
Cavity Tools	Rougher: 02582046 Finisher: 02582047
Cartridge Weight	2.7 oz (75 grams)
Coil Weight	3.1 oz (88 grams)
Cartridge Material	Steel with hardened work surfaces. Zinc-plated exposed surfaces. Buna N or Viton® o-rings. Solid thermoplastic polyester back-up rings.
Coil Material	Class N, 200°C high temperature magnet wire, steel shell, polyester encapsulation
Seal Kits	Buna-N P/N: 02610184 Viton® P/N: 02610185

Performance

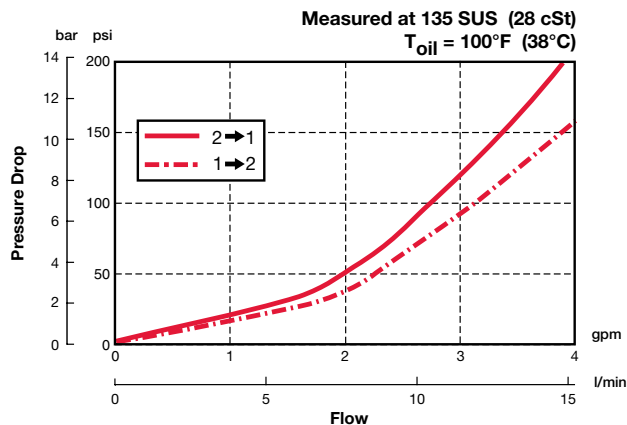

Dimensions

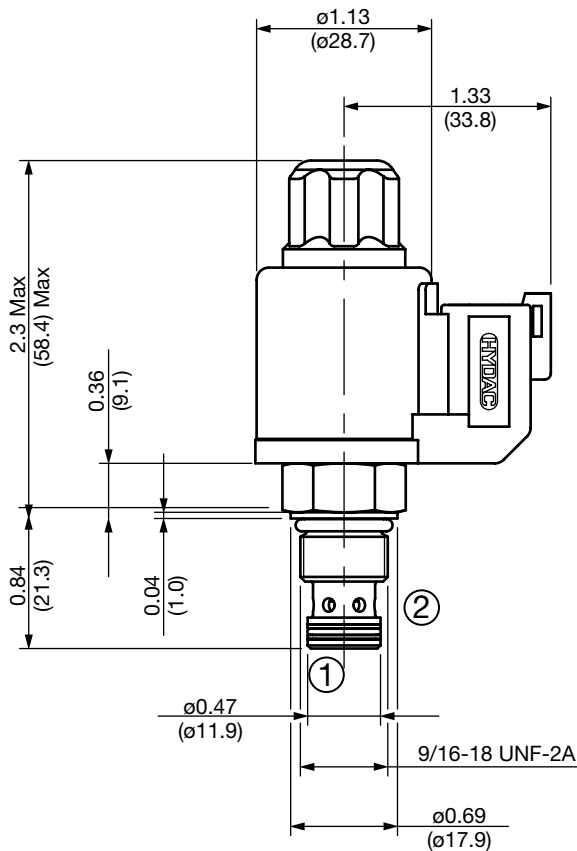
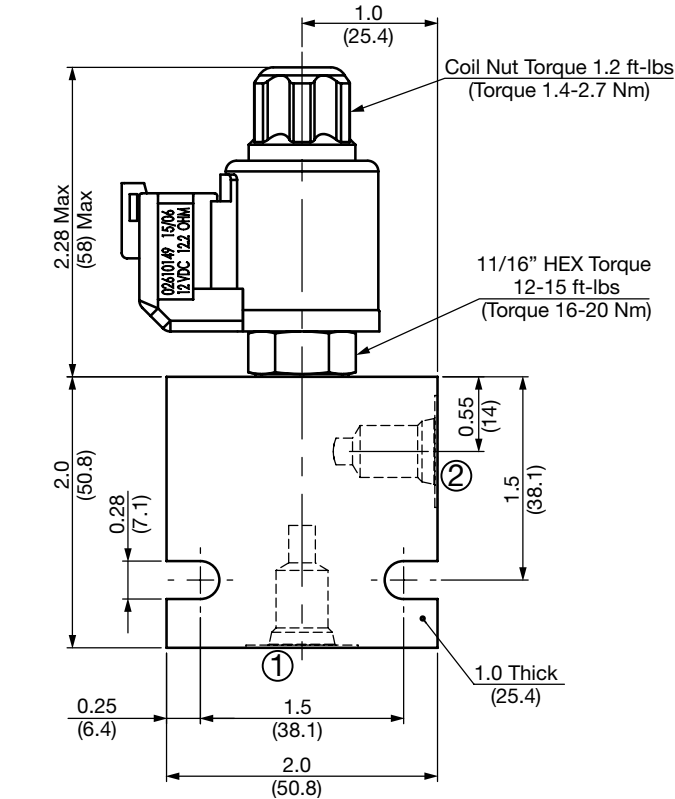

All measurements in inches (mm).
Subject to technical modifications

Model Code

WK06W-01 M-C-N-24-DN

Valve Model _____

Override Option _____
 blank = No manual override
 M = Manual override, push type
 (for availability consult factory)

Body & Ports _____
 C = Cartridge only
 AS4 = SAE-4 Ports, aluminum body
 SS4 = SAE-4 Ports, steel body

Seals _____
 N = Buna-N
 V = Viton®

Coil Voltage _____
 0 = No coil, cartridge only
 DC 12 = 12 VDC
 24 = 24 VDC
 AC 115 = 105 VDC (only available with connector DG)
 230 = 205 VDC (only available with connector DG)
 (All model 32-1329 coils are DC. AC models require an external diode bridge mounted outside the coil)**

Coil Connector _____
 DG = EN 175301-803-B (IP65 Rated)**
 DC DL = Leadwires (2) - 18" long (46 cm) AWG18, TYPE UL 1815 (IP69K Rated)*
 DN = Deutsch DT04-2P intergral molded (IP69K Rated)*

Use mating plug EN 175301-803-B without diode bridge for DC voltages P/N 02600570
 Use mating plug EN 175301-803-B w/diode bridge for AC voltages P/N 02600582

Coil Model 32-1329

For other coil connector types consult factory

** Mating Plugs sold separately

*Coils with internal transient suppression diode are available, consult factory.

Operating Limits

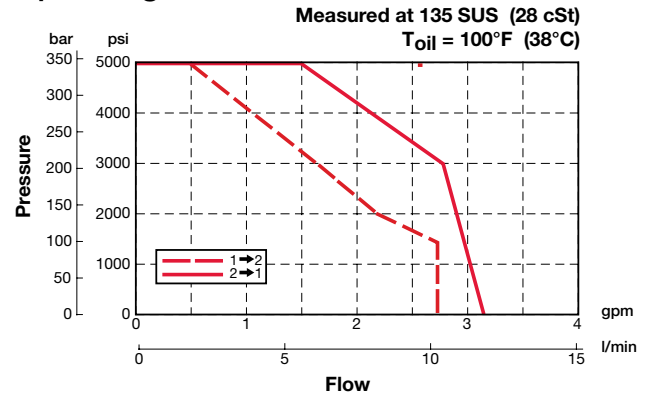

Standard Line Bodies*

Code	Part No	Material	Pressure Rating	Weight
FH062-AS4	02600491	Aluminum, anodized	3500 psi (245 bar)	0.33 lbs (0.15 kg)
FH062-SS4	02600490	Steel, Zinc plated	6000 psi (420 bar)	0.97 lbs (0.44 kg)

*Please refer to Line Bodies & Cavities section for details

SOLENOID VALVES

WK08W-01

Spool Type, Normally Closed, Direct Acting

Up to 5 gpm (19 l/min) • 5000 psi (350 bar)

Hydraulic Symbol

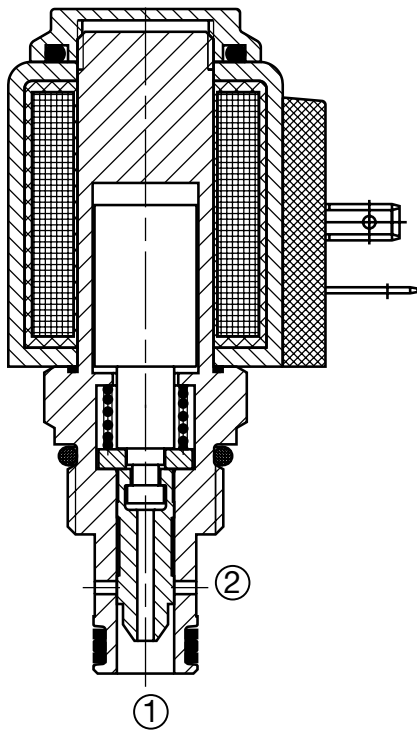
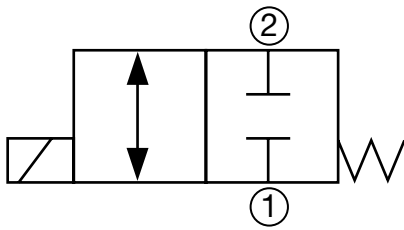

Description

A screw-in cartridge, solenoid operated, 2-way, 2 position, normally closed, direct acting, spool type, intended for use as a bi-directional flow blocking valve.

Operation

When de-energized the WK08W blocks flow in both directions. When energized the spool shifts and opens the bidirectional flow path.

Operation of Manual Override Option: To override, remove the coil nut, turn the override knurled knob counterclockwise until it stops. The override will remain activated until the knob is turned clockwise to original position. The manual override option is intended for emergency use, not for continuous duty operation.

Features

- Screw type manual override option

Specifications

Operating Pressure	5000 psi (350 bar)
Nominal Flow	5 gpm (19 l/min)
Internal Leakage	5.5 cu in/min. at 3000 psi and 158 SUS (90 cc/min at 210 bar and 34 cSt)
Fluid Operating Temp. Range	-4° to 248°F (-20° to 120°C) <i>(Consult factory for usage at temp. outside range.)</i>
Ambient Temperature Range	-4° to 140°F (-20° to 60°C)
Coil Duty Rating	Continuous from 85% to 115% of nominal voltage
Current Draw @ 68°F (20°C)	1.5 A at 12VDC; 0.8 A at 24VDC
Min. Pull-in Voltage @ 68°F (20°C)	85% of nominal @ 5000 psi (350 bar)
Fluid Compatibility	Mineral-based or synthetics with lubricating properties
Viscosity	50 to 2000 SUS (7.4 to 420 cSt)
Filtration	21/19/16 or cleaner (per ISO 4406). Use with filter rated $\beta_{10} \geq 200$.
Installation	No orientation restrictions
Cavity	FC08-2 (see <i>Line Bodies & Cavities</i> section)
Cavity Tools	Rougher: 02580090 Finisher: 02580091
Cartridge Weight	0.38 Lbs. (0.17 kg)
Coil Weight	0.42 Lbs. (0.19 kg)
Cartridge Material	Steel with hardened work surfaces. Zinc-plated exposed surfaces. Buna N or Viton® o-rings. PTFE back-up rings.
Coil Material	Class N high temperature magnet wire, steel shell, polyamid encapsulation.
Seal Kits	Buna-N FS082-N P/N: 03033920 Viton® FS082-V P/N: 03051756

Performance

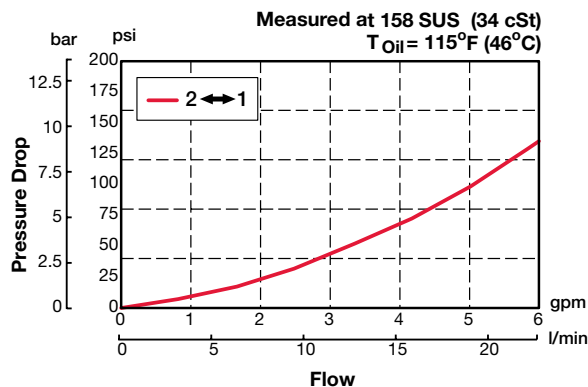

Dimensions

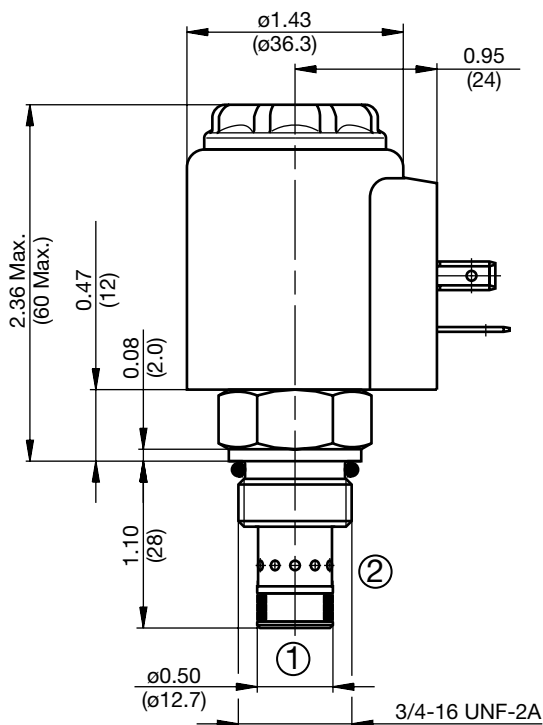
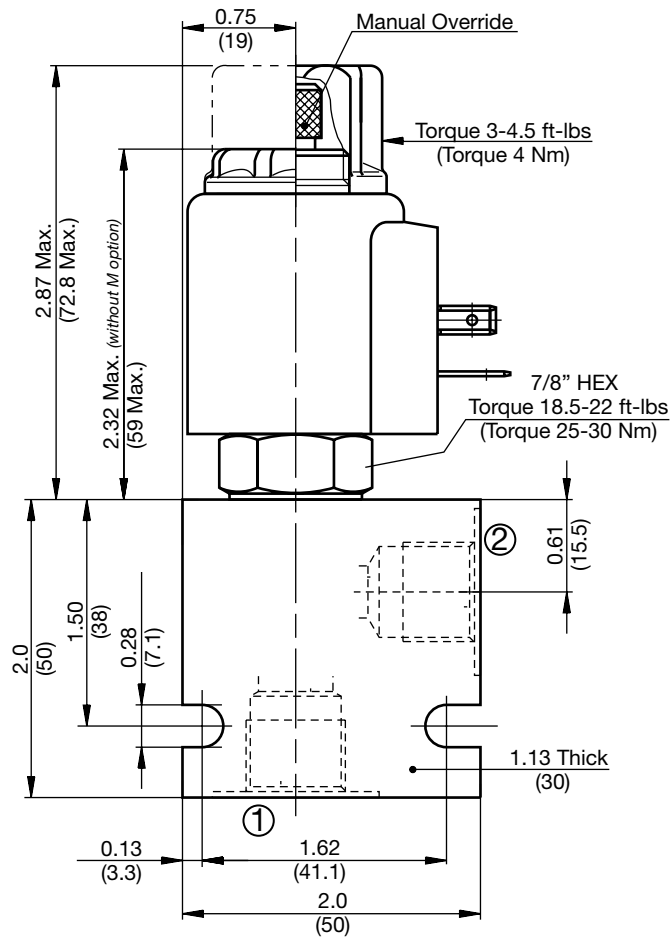

All measurements in inches (mm).
Subject to technical modifications

Model Code

WK08W-01 M-C-N-24 DN

- Valve Model** _____
- Override Option** _____
blank = No manual override
M = Manual override, screw type
- Body & Ports** _____
C = Cartridge only
AS6 = SAE-6 Ports, aluminum body
SS6 = SAE-6 Ports, steel body
- Seals** _____
N = Buna-N
V = Viton®
- Coil Voltage** _____
0 = No coil, cartridge only
- DC** _____
12 = 12 VDC
24 = 24 VDC
36 = 36 VDC
110 = 110 VDC (only available with connector DG)
- AC** _____
24 = 24 VAC
115 = 115 VAC (AC coils internally full wave rectified)
230 = 230 VAC
- Coil Connector** _____
DC _____
DG = EN 175301-803-A
DS = Dual spade (SAEJ858a)*
DL = Leadwires (2) - 18" long (46 cm)*
DW = WeatherPak™ on leadwires - 9.5" long (24 cm)*
DN = Deutsch™ DT04-2P, molded, axial (IP69K Rated)*
DT = Amp Junior Timer™, molded, radial mount*
- AC AG** = EN 175301-803-A

Coil Model 40-1836

For other coil connector types consult factory

*Coils with internal diode are available, consult factory.

Standard Line Bodies*

Code	Part No	Material	Pressure Rating	Weight
FH082-AS6	03011409	Aluminum, anodized	3500 psi (245 bar)	0.33 lbs (0.15 kg)
FH082-SS6	00560917	Steel, Zinc plated	6000 psi (420 bar)	1.0 lbs (0.45 kg)

*Please refer to Line Bodies & Cavities section for details

SOLENOID VALVES

WK10W-01

Spool Type, Normally Closed, Direct Acting

Up to 9 gpm (35 l/min) • 5000 psi (350 bar)

Hydraulic Symbol

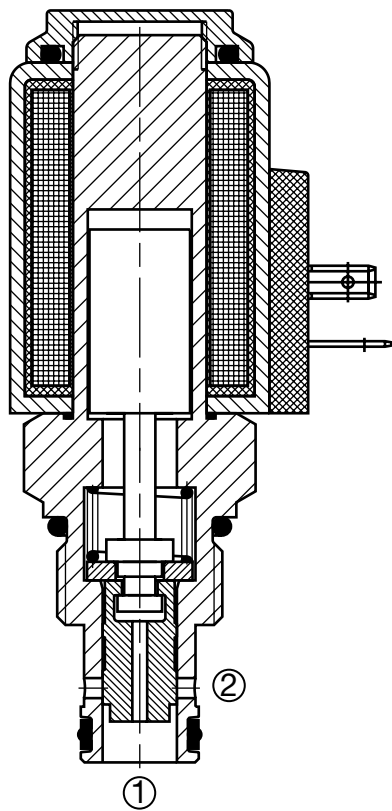
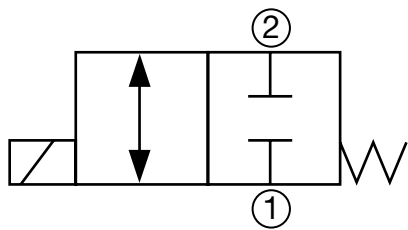

Description

A screw-in cartridge, solenoid operated, 2-way, 2 position, normally closed, direct acting, spool type, intended for use as a bi-directional flow blocking valve.

Operation

When de-energized the WK10W blocks flow in both directions. When energized the spool shifts and opens the bidirectional flow path.

Operation of Manual Override Option: To override, remove the coil nut, turn the override knurled knob counterclockwise until it stops. The override will remain activated until the knob is turned clockwise to original position. The manual override option is intended for emergency use, not for continuous duty operation.

Features

- Screw type manual override option

Specifications

Operating Pressure	5000 psi (350 bar)
Nominal Flow	9 gpm (35 l/min)
Internal Leakage	7.3 cu in/min. at 5000 psi and 158 SUS (120 cc/min at 350 bar and 34 cSt)
Fluid Operating Temp. Range	-4° to 248°F (-20° to 120°C) <i>(Consult factory for usage at temp. outside range.)</i>
Ambient Temperature Range	-4° to 140°F (-20° to 60°C)
Coil Duty Rating	Continuous from 85% to 115% of nominal voltage
Current Draw @ 68°F (20°C)	2.22 A at 12VDC; 1.13 A at 24VDC
Min. Pull-in Voltage @ 68°F (20°C)	85% of nominal @ 5000 psi (350 bar)
Fluid Compatibility	Mineral-based or synthetics with lubricating properties
Viscosity	50 to 2000 SUS (7.4 to 420 cSt)
Filtration	21/19/16 or cleaner (per ISO 4406). Use with filter rated $\beta_{10} \geq 200$.
Installation	No orientation restrictions
Cavity	FC10-2 (see <i>Line Bodies & Cavities</i> section)
Cavity Tools	Rougher: 02580274 Finisher: 02580247
Cartridge Weight	0.48 Lbs. (0.22 kg)
Coil Weight	0.51 Lbs. (0.23 kg)
Cartridge Material	Steel with hardened work surfaces. Zinc-plated exposed surfaces. Buna N or Viton® o-rings. PTFE back-up rings.
Coil Material	Class N high temperature magnet wire, steel shell, polyamid encapsulation.
Seal Kits	Buna-N FS102-N P/N: 03033872 Viton® FS102-V P/N: 03051757

Performance

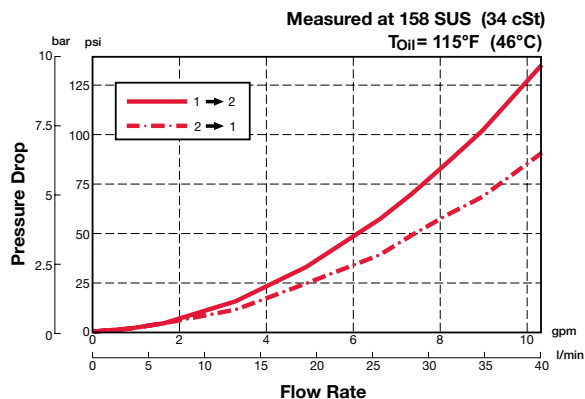

Dimensions

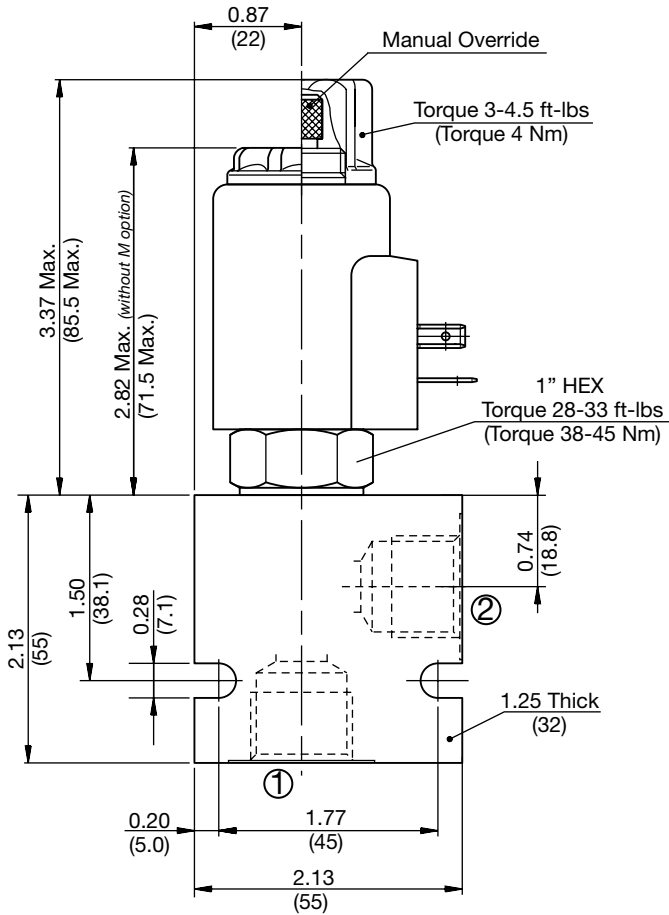

Model Code

WK10W-01 M-C-N-24 DN

- Valve Model** _____
- Override Option** _____
 blank = No manual override
 M = Manual override, screw type
- Body & Ports** _____
 C = Cartridge only
 AS8 = SAE-8 Ports, aluminum body
 SS8 = SAE-8 Ports, steel body
- Seals** _____
 N = Buna-N
 V = Viton®
- Coil Voltage** _____
 0 = No coil, cartridge only
- DC** _____
 12 = 12 VDC
 24 = 24 VDC
 36 = 36 VDC
 110 = 110 VDC (only available with connector DG)
- AC** _____
 24 = 24 VAC
 115 = 115 VAC (AC coils internally full wave rectified)
 230 = 230 VAC
- Coil Connector** _____
 DC DG = EN 175301-803-A
 DS = Dual spade (SAEJ858a)*
 DL = Leadwires (2) - 18" long (46 cm)*
 DW = WeatherPak™ on leadwires - 9.5" long (24 cm)*
 DN = Deutsch™ DT04-2P, molded, axial (IP69K Rated)*
 DT = Amp Junior Timer™, molded, radial mount*
- AC AG** = EN 175301-803-A

Coil Model 50-1836

For other coil connector types consult factory

*Coils with internal diode are available, consult factory.

All measurements in inches (mm).
 Subject to technical modifications

PN#02087369 / 10.19 / CHD1110-1389

Standard Line Bodies*

Code	Part No	Material	Pressure Rating	Weight
FH102-AS8	03037778	Aluminum, anodized	3500 psi (245 bar)	0.40 lbs (0.18 kg)
FH102-SS8	03037612	Steel, Zinc plated	6000 psi (420 bar)	1.16 lbs (0.53 kg)

*Please refer to Line Bodies & Cavities section for details

SOLENOID VALVES

WK06C-01

Spool Type, Direct Acting

Up to 4 gpm (15 l/min) • 5000 psi (350 bar)

Hydraulic Symbol

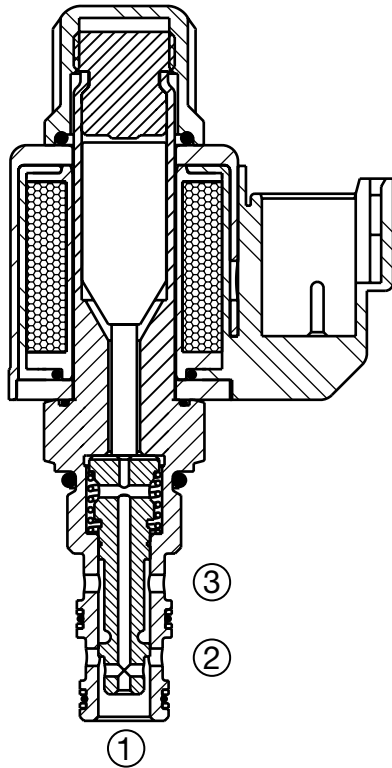
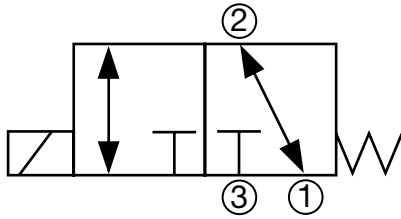

Description

A screw-in cartridge, solenoid operated, 3-way, 2 position, direct acting, spool type valve.

Operation

When de-energized the WK06C allows flow from port 2 to port 1 bi-directionally, while blocking flow at port 3. When energized the spool shifts and opens flow from port 2 to port 3 bi-directionally, while blocking flow at port 1.

Specifications

Operating Pressure	5000 psi (350 bar)
Nominal Flow	4 gpm (15 l/min)
Internal Leakage	5.5 cu in/min. at 3000 psi and 135 SUS (90 cc/min at 207 bar and 28 cSt)
Fluid Operating Temp. Range	-20° to 248°F (-29° to 120°C)
Ambient Temperature Range	-20° to 140°F (-29° to 60°C)
Coil Duty Rating	Continuous from 85% to 115% of nominal voltage
Current Draw at 68°F (20°C)	984 mA at 12VDC; 492 mA at 24VDC
Minimum Pull-in Current to Operate Valve	70% of nominal amperage
Typical Response Time (Varies with Pressure and Flow)	On: 30 to 60 ms Off: 20 to 40 ms
Fluid Compatibility	Mineral-Based or Synthetics with lubricating properties
Viscosity	50 to 2000 SUS (7.4 to 420 cSt)
Filtration	21/19/16 or cleaner per (ISO 4406)
Installation	No orientation restrictions
Cavity	FC06-3 (see <i>Line Bodies & Cavities</i> section)
Cavity Tools	Rougher: 02582050 Finisher: 02582051
Cartridge Weight	3.0 oz (85 grams)
Coil Weight	3.1 oz (88 grams)
Cartridge Material	Steel with hardened work surfaces. Zinc plated solenoid tube surface. Buna N or Viton® o-rings Solid thermoplastic polyester back-up rings.
Coil Material	Class N, 200°C high temperature magnet wire, steel shell, polyester encapsulation
Seal Kits	Buna-N P/N: 02610186 Viton® P/N: 02610187

Performance

Measured at 135 SUS (28 cSt)
T_{oil} = 100°F (38°C)

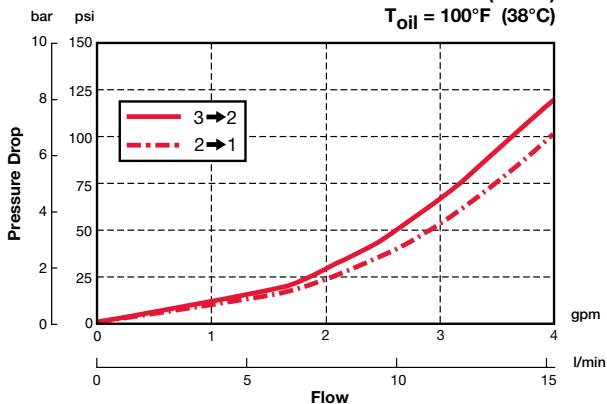

Dimensions

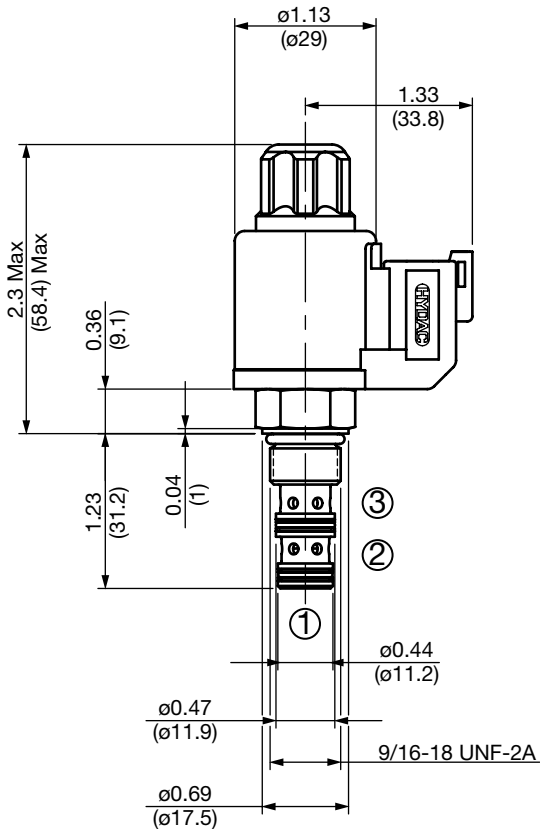
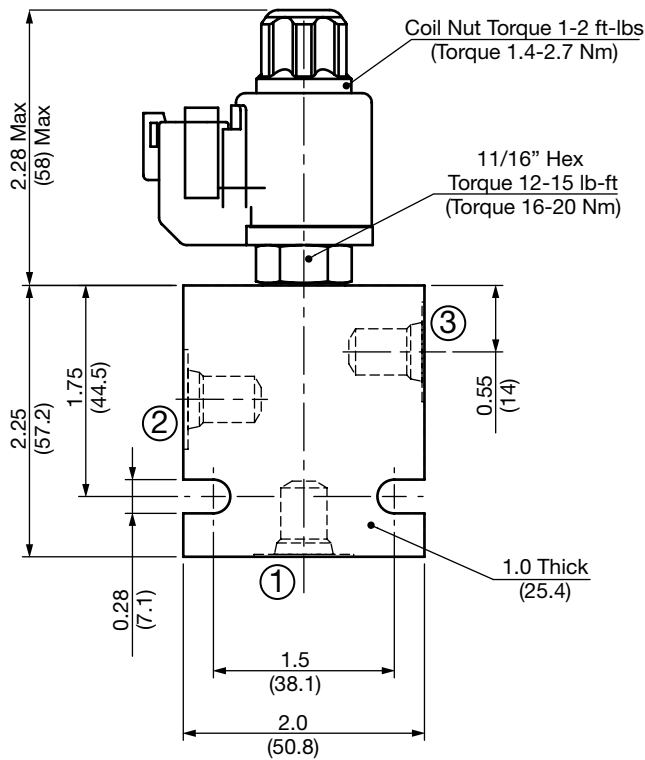

All measurements in inches (mm).
Subject to technical modifications

Model Code

WK06C-01 M-C-N-24 DN

Valve Model _____

Override Option _____
 blank = No manual override
 M = Manual override, push type
 (for availability consult factory)

Body & Ports _____
 C = Cartridge only
 AS4 = SAE-4 Ports, aluminum body
 SS4 = SAE-4 Ports, steel body

Seals _____
 N = Buna-N
 V = Viton®

Coil Voltage _____
 0 = No coil, cartridge only
 DC 12 = 12 VDC
 24 = 24 VDC
 AC 115 = 105 VDC (only available with connector DG)
 230 = 205 VDC (only available with connector DG)
 (All model 32-1329 coils are DC. AC models require an external diode bridge mounted outside the coil)**

Coil Connector _____
 DG = EN 175301-803-B (IP65 Rated)**
 DC DL = Leadwires (2) - 18" long (46 cm) AWG18, TYPE UL 1815 (IP69K Rated)*
 DN = Deutsch DT04-2P integral molded (IP69K Rated)*

Use mating plug EN 175301-803-B without diode bridge for DC voltages P/N 02600570
 Use mating plug EN 175301-803-B w/diode bridge for AC voltages P/N 02600582

Coil Model 32-1329

For other coil connector types consult factory

**Mating Plugs sold separately

*Coils with internal transient suppression diode are available, consult factory.

Operating Limits

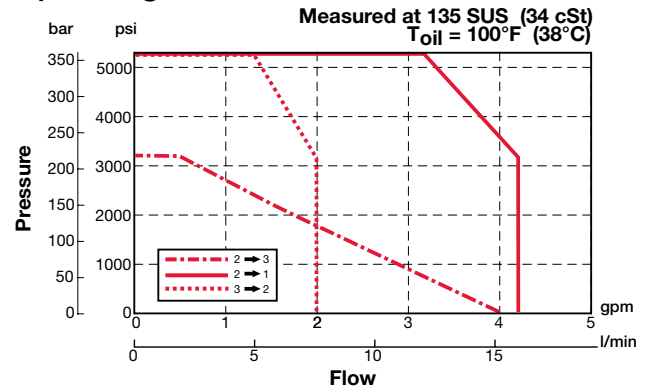

Standard Line Bodies*

Code	Part No	Material	Pressure Rating	Weight
FH063-AS4	02600492	Aluminum, anodized	3500 psi (245 bar)	0.37 lbs (0.17 kg)
FH063-SS4	02600493	Steel, zinc plated	6000 psi (420 bar)	1.07 lbs (0.43 kg)

*Please refer to Line Bodies & Cavities section for details

SOLENOID VALVES

WK08C-01

Spool Type, Direct Acting

Up to 5 gpm (19 l/min) • 5000 psi (350 bar)

Hydraulic Symbol

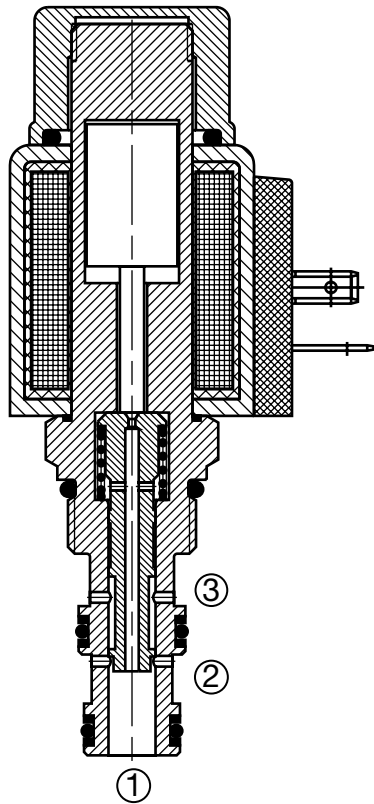
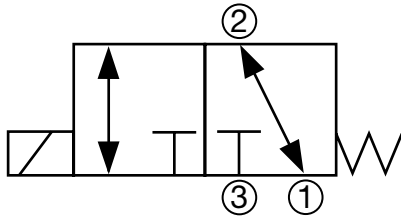

Description

A screw-in cartridge, solenoid operated, 3-way, 2 position, direct acting, spool type valve.

Operation

When de-energized the WK08C allows flow from port 2 to port 1 bi-directionally, while blocking flow at port 3. When energized the spool shifts and opens flow from port 2 to port 3 bi-directionally, while blocking flow at port 1.

Operation of Manual Override Option: To override, push and hold the override button. The override is not detented. The manual override option is intended for emergency use, not for continuous duty operation.

Features

- Push type manual override button, protected by rubber cap

Specifications

Operating Pressure	5000 psi (350 bar)
Nominal Flow	5 gpm (19 l/min)
Internal Leakage	5.5 cu in/min. at 3600 psi and 158 SUS (90 cc/min at 250 bar and 34 cSt)
Fluid Operating Temp. Range	-4° to 248°F (-20° to 120°C) <i>(Consult factory for usage at temp. outside range.)</i>
Ambient Temperature Range	-4° to 140°F (-20° to 60°C)
Coil Duty Rating	Continuous from 85% to 115% of nominal voltage
Current Draw @ 68°F (20°C)	1.5 A at 12VDC; 0.8 A at 24VDC
Min. Pull-in Voltage @ 68°F (20°C)	85% of nominal @ 5000 psi (350 bar)
Fluid Compatibility	Mineral-based or synthetics with lubricating properties
Viscosity	50 to 2000 SUS (7.4 to 420 cSt)
Filtration	21/19/16 or cleaner (per ISO 4406). Use with filter rated $\beta_{10} \geq 200$.
Installation	No orientation restrictions
Cavity	FC08-3 (see <i>Line Bodies & Cavities</i> section)
Cavity Tools	Rougher: 02580086 Finisher: 02580087
Cartridge Weight	0.40 Lbs. (0.18 kg)
Coil Weight	0.42 Lbs. (0.19 kg)
Cartridge Material	Steel with hardened work surfaces. Zinc-plated exposed surfaces. Buna N or Viton® o-rings. PTFE back-up rings.
Coil Material	Class N high temperature magnet wire, steel shell, polyamid encapsulation.
Seal Kits	Buna-N P/N: 03054795 Viton® P/N: 02591059

Performance

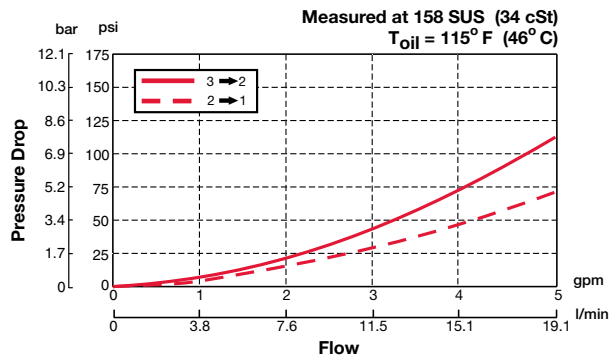

Dimensions

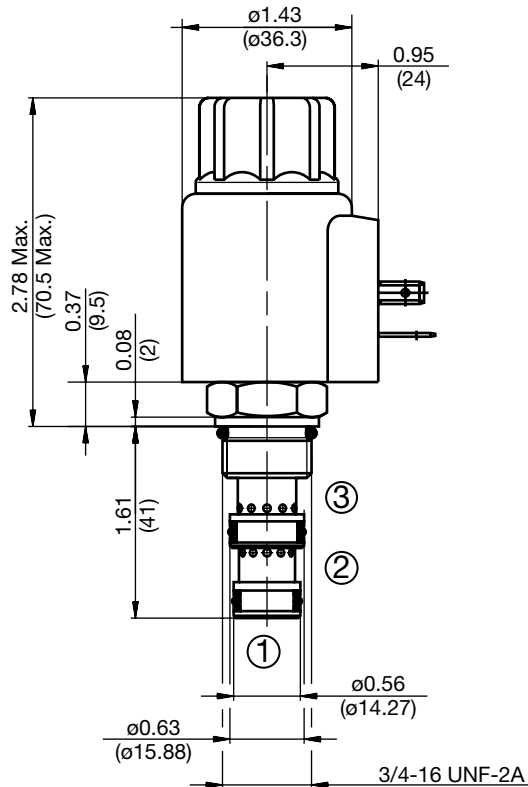
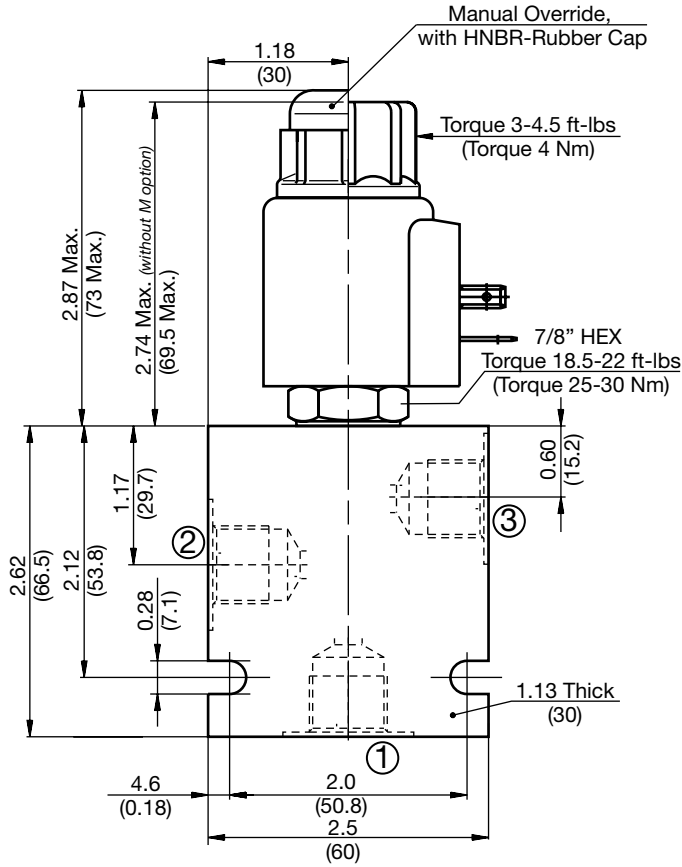

Model Code

WK08C-01 M-C-N-24 DN

- Valve Model** _____
- Override Option** _____
 blank = No manual override
 M = Manual override, push type
- Body & Ports** _____
 C = Cartridge only
 AS6 = SAE-6 Ports, aluminum body
 SS6 = SAE-6 Ports, steel body
- Seals** _____
 N = Buna-N
 V = Viton®
- Coil Voltage** _____
 0 = No coil, cartridge only
- DC** _____
 12 = 12 VDC
 24 = 24 VDC
 36 = 36 VDC
 110 = 110 VDC (only available with connector DG)
- AC** _____
 24 = 24 VAC
 115 = 115 VAC (AC coils internally full wave rectified)
 230 = 230 VAC
- Coil Connector** _____
 DC _____
 DG = EN 175301-803-A
 DS = Dual spade (SAEJ858a)*
 DL = Leadwires (2) - 18" long (46 cm)*
 DW = WeatherPak™ on leadwires - 9.5" long (24 cm)*
 DN = Deutsch™ DT04-2P, molded, axial (IP69K Rated)*
 DT = Amp Junior Timer™, molded, radial mount*
- AC AG** = EN 175301-803-A

Coil Model 40-1836

For other coil connector types consult factory

*Coils with internal diode are available, consult factory.

Operating Limits

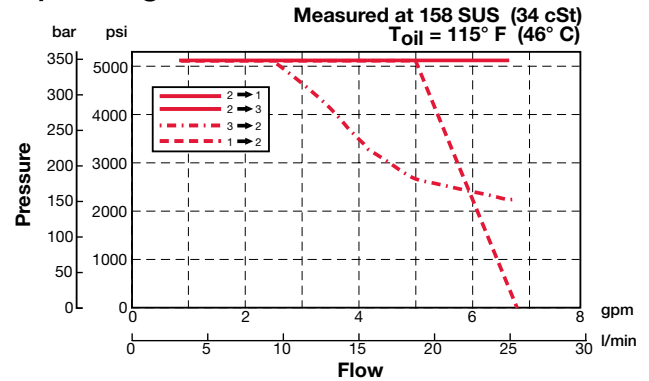

Standard Line Bodies*

Code	Part No	Material	Pressure Rating	Weight
FH083-AS6	03011424	Aluminum, anodized	3500 psi (245 bar)	0.58 lbs (0.26 kg)
FH083-SS6	00560920	Steel, zinc plated	6000 psi (420 bar)	1.7 lbs (0.77 kg)

*Please refer to Line Bodies & Cavities section for details

All measurements in inches (mm).
 Subject to technical modifications

SOLENOID VALVES

WK10C-01

Spool Type, Direct Acting

Up to 8.4 gpm (32 l/min) • 5000 psi (350 bar)

Hydraulic Symbol

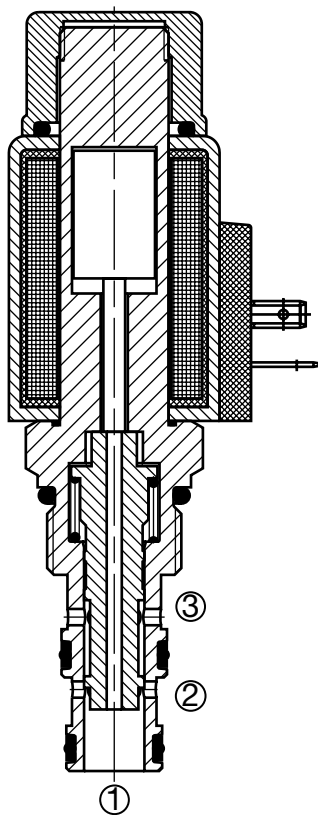
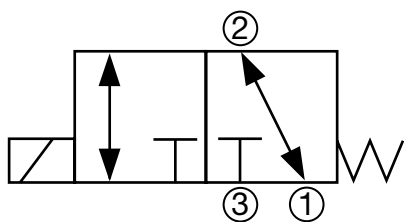

Description

A screw-in cartridge, solenoid operated, 3-way, 2 position, direct acting, spool type valve.

Operation

When de-energized the WK10C allows flow from port 2 to port 1 bi-directionally, while blocking flow at port 3. When energized the spool shifts and opens flow from port 2 to port 3 bi-directionally, while blocking flow at port 1.

Operation of Manual Override Option: To override, push and hold the override button. The override is not detented. The manual override option is intended for emergency use, not for continuous duty operation.

Features

- Push type manual override button, protected by rubber cap

Specifications

Operating Pressure	5000 psi (350 bar)
Nominal Flow	8.4 gpm (32 l/min)
Internal Leakage	7.3 cu in/min. at 3600 psi and 158 SUS (120 cc/min at 250 bar and 34 cSt)
Fluid Operating Temp. Range	-4° to 248°F (-20° to 120°C) <i>(Consult factory for usage at temp. outside range.)</i>
Ambient Temperature Range	-4° to 140°F (-20° to 60°C)
Coil Duty Rating	Continuous from 85% to 115% of nominal voltage
Current Draw @ 68°F (20°C)	2.22 A at 12VDC; 1.13 A at 24VDC
Min. Pull-in Voltage @ 68°F (20°C)	85% of nominal @ 5000 psi (350 bar)
Fluid Compatibility	Mineral-based or synthetics with lubricating properties
Viscosity	50 to 2000 SUS (7.4 to 420 cSt)
Filtration	21/19/16 or cleaner (per ISO 4406). Use with filter rated $\beta_{10} \geq 200$.
Installation	No orientation restrictions
Cavity	FC10-3 (see <i>Line Bodies & Cavities</i> section)
Cavity Tools	Rougher: 02580092 Finisher: 02580093
Cartridge Weight	0.52 Lbs. (0.24 kg)
Coil Weight	0.51 Lbs. (0.23 kg)
Cartridge Material	Steel with hardened work surfaces. Zinc-plated exposed surfaces. Buna N or Viton® o-rings. PTFE back-up rings.
Coil Material	Class N high temperature magnet wire, steel shell, polyamid encapsulation.
Seal Kits	Buna-N P/N: 03071274 Viton® P/N: 03049443

Performance

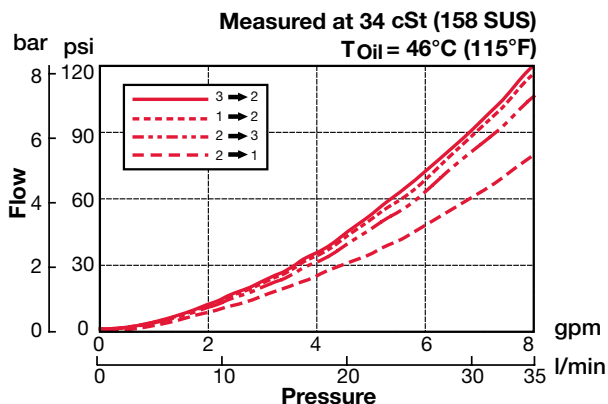

Dimensions

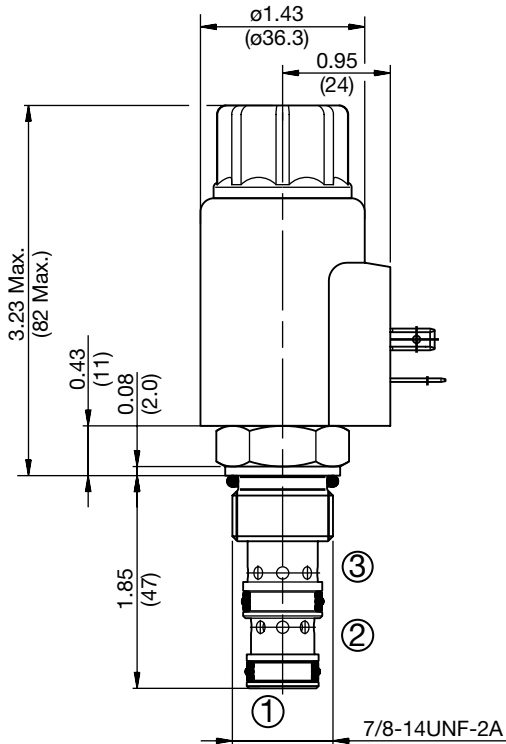
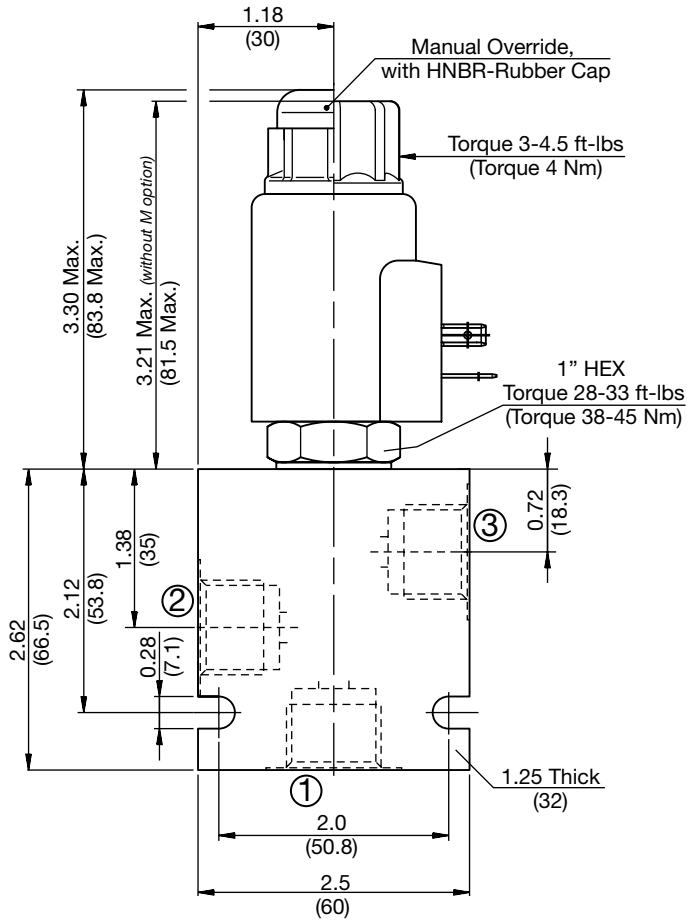

All measurements in inches (mm).
Subject to technical modifications

PN#02087369 / 10.19 / CHD1110-1389

Model Code

WK10C-01 M-C-N-24 DN

Valve Model

Override Option

- blank = No manual override
- M = Manual override, push type

Body & Ports

- C = Cartridge only
- AS8 = SAE-8 Ports, aluminum body
- SS8 = SAE-8 Ports, steel body

Seals

- N = Buna-N
- V = Viton®

Coil Voltage

- 0 = No coil, cartridge only

DC

- 12 = 12 VDC
- 24 = 24 VDC
- 36 = 36 VDC
- 110 = 110 VDC (only available with connector DG)

AC

- 24 = 24 VAC
- 115 = 115 VAC (AC coils internally full wave rectified)
- 230 = 230 VAC

Coil Connector

- DC DG = EN 175301-803-A
- DS = Dual spade (SAEJ858a)*
- DL = Leadwires (2) - 18" long (46 cm)*
- DW = WeatherPak™ on leadwires - 9.5" long (24 cm)*
- DN = Deutsch™ DT04-2P, molded, axial (IP69K Rated)*
- DT = Amp Junior Timer™, molded, radial mount*

- AC AG = EN 175301-803-A

Coil Model 50-1836

For other coil connector types consult factory

*Coils with internal diode are available, consult factory.

Operating Limits

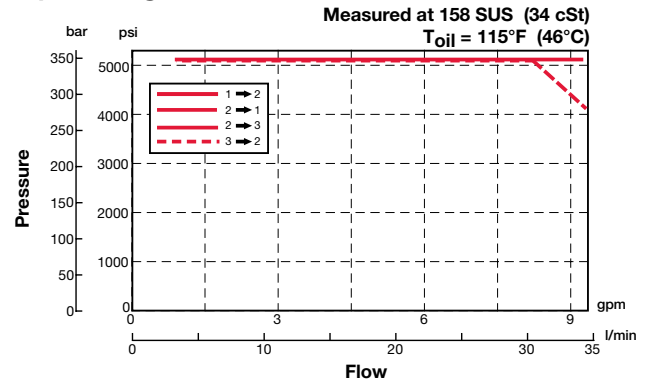

Standard Line Bodies*

Code	Part No	Material	Pressure Rating	Weight
FH103-AS8	03038095	Aluminum, anodized	3500 psi (245 bar)	0.60 lbs (0.27 kg)
FH103-SS8	03037704	Steel, zinc plated	6000 psi (420 bar)	1.74 lbs (0.79 kg)

*Please refer to Line Bodies & Cavities section for details

SOLENOID VALVES

WK10C-40

Spool Type, Direct Acting

Up to 8.4 gpm (32 l/min) • 5000 psi (350 bar)

Hydraulic Symbol

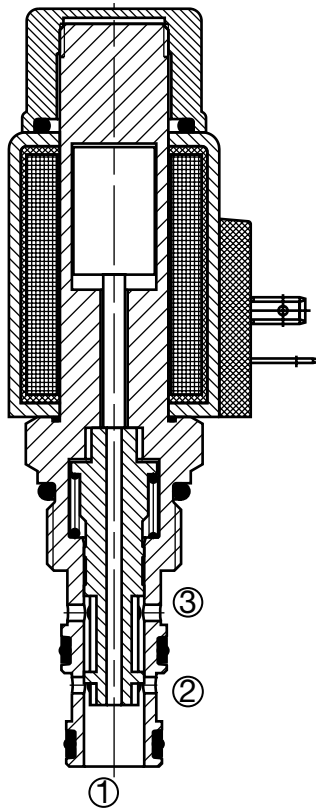
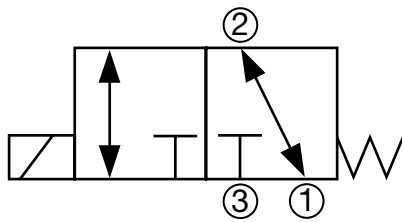

Description

A screw-in cartridge, solenoid operated, 3-way, 2 position, direct acting, spool type valve, optimized for low pressure drop applications.

Operation

When de-energized the WK10C allows flow from port 2 to port 1 bi-directionally, while blocking flow at port 3. When energized the spool shifts and opens flow from port 2 to port 3 bi-directionally, while blocking flow at port 1.

Operation of Manual Override Option: To override, push and hold the override button. The override is not detented. The manual override option is intended for emergency use, not for continuous duty operation.

Features

- Push type manual override button, protected by rubber cap

Specifications

Operating Pressure	5000 psi (350 bar)
Nominal Flow	8.4 gpm (32 l/min)
Internal Leakage	18 cu in./min. at 3600 psi and 158 SUS (250 cc/min at 250 bar and 34 cSt)
Fluid Operating Temp. Range	-4° to 248°F (-20° to 120°C) (Consult factory for usage at temp. outside range.)
Ambient Temperature Range	-4° to 140°F (-20° to 60°C)
Coil Duty Rating	Continuous from 85% to 115% of nominal voltage
Current Draw @ 68°F (20°C)	2.22 A at 12VDC; 1.13 A at 24VDC
Min. Pull-in Voltage @ 68°F (20°C)	85% of nominal @ 5000 psi (350 bar)
Fluid Compatibility	Mineral-based or synthetics with lubricating properties
Viscosity	50 to 2000 SUS (7.4 to 420 cSt)
Filtration	21/19/16 or cleaner (per ISO 4406). Use with filter rated $\beta_{10} \geq 200$.
Installation	No orientation restrictions
Cavity	FC10-3 (see <i>Line Bodies & Cavities</i> section)
Cavity Tools	Rougher: 02580092 Finisher: 02580093
Cartridge Weight	0.52 Lbs. (0.24 kg)
Coil Weight	0.51 Lbs. (0.23 kg)
Cartridge Material	Steel with hardened work surfaces. Zinc-plated exposed surfaces. Buna N or Viton® o-rings. PTFE back-up rings.
Coil Material	Class N high temperature magnet wire, steel shell, polyamid encapsulation.
Seal Kits	Buna-N P/N: 03071274 Viton® P/N: 03049443

Performance

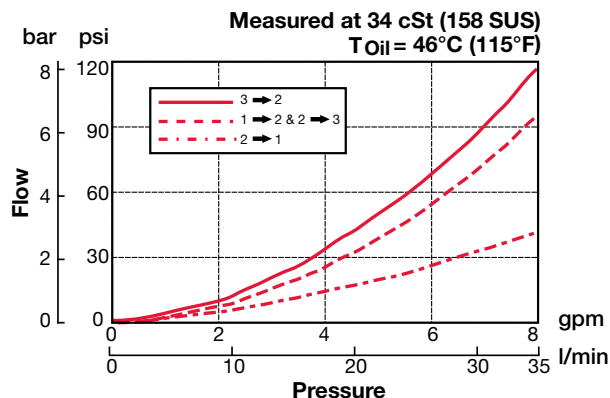

Dimensions

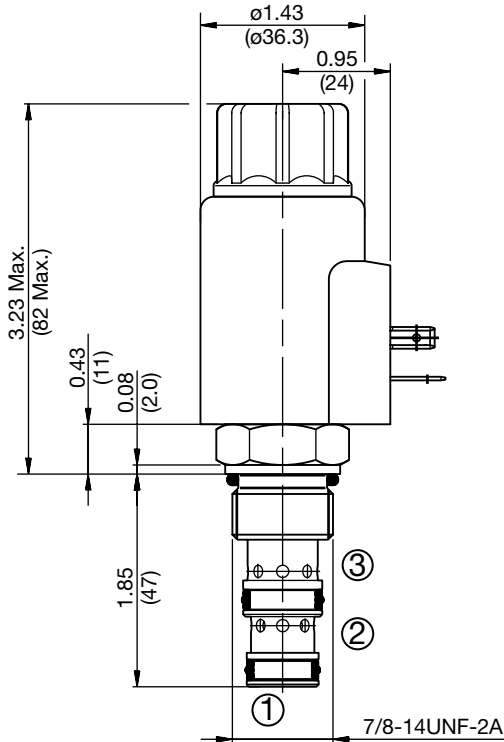
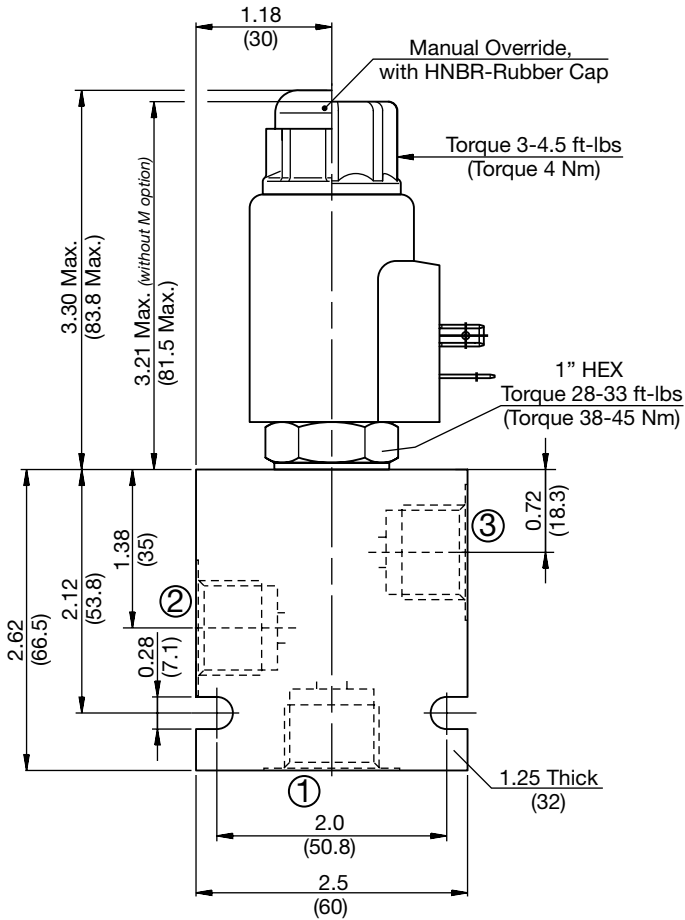

All measurements in inches (mm).
Subject to technical modifications

PN#02087369 / 10.19 / CHD1110-1389

Model Code

WK10C-40 M-C-N-24 DN

- Valve Model** _____
- Override Option** _____
 blank = No manual override
 M = Manual override, push type
- Body & Ports** _____
 C = Cartridge only
 AS8 = SAE-8 Ports, aluminum body
 SS8 = SAE-8 Ports, steel body
- Seals** _____
 N = Buna-N
 V = Viton®
- Coil Voltage** _____
 0 = No coil, cartridge only
- DC** _____
 12 = 12 VDC
 24 = 24 VDC
 36 = 36 VDC
 110 = 110 VDC (only available with connector DG)
- AC** _____
 24 = 24 VAC
 115 = 115 VAC (AC coils internally full wave rectified)
 230 = 230 VAC
- Coil Connector** _____
 DC DG = EN 175301-803-A
 DS = Dual spade (SAEJ858a)*
 DL = Leadwires (2) - 18" long (46 cm)*
 DW = WeatherPak™ on leadwires - 9.5" long (24 cm)*
 DN = Deutsch™ DT04-2P, molded, axial (IP69K Rated)*
 DT = Amp Junior Timer™, molded, radial mount*
- AC AG** = EN 175301-803-A
- Coil Model 50-1836**
 For other coil connector types consult factory
- *Coils with internal diode are available, consult factory.

Operating Limits

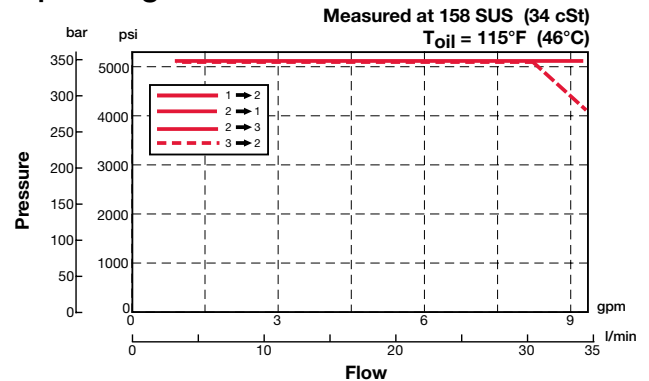

Standard Line Bodies*

Code	Part No	Material	Pressure Rating	Weight
FH103-AS8	03038095	Aluminum, anodized	3500 psi (245 bar)	0.60 lbs (0.27 kg)
FH103-SS8	03037704	Steel, zinc plated	6000 psi (420 bar)	1.74 lbs (0.79 kg)

*Please refer to Line Bodies & Cavities section for details

SOLENOID VALVES

WK08D-01

Spool Type, Direct Acting

Up to 5 gpm (19 l/min) • 5000 psi (350 bar)

Hydraulic Symbol

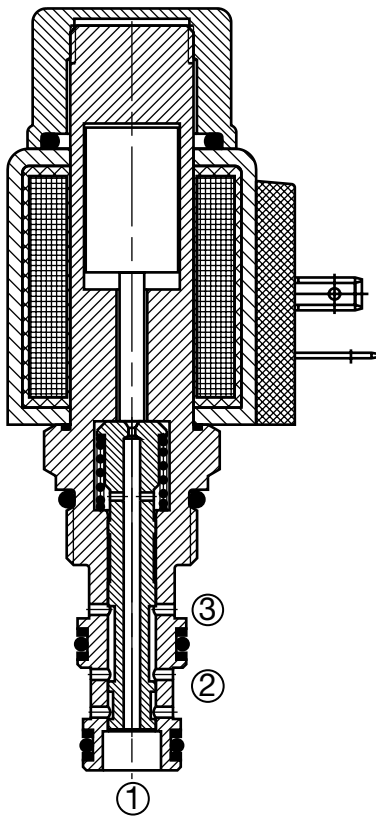
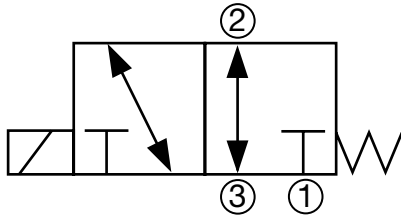

Description

A screw-in cartridge, solenoid operated, 3-way, 2 position, direct acting, spool type valve.

Operation

When de-energized the WK08D allows flow from port 3 to port 2 bi-directionally, while blocking flow at port 1. When energized the spool shifts and opens flow from port 2 to port 1 bi-directionally, while blocking flow at port 3.

Operation of Manual Override Option: To override, push and hold the override button. The override is not detented. The manual override option is intended for emergency use, not for continuous duty operation.

Features

- Push type manual override button, protected by rubber cap

Specifications

Operating Pressure	5000 psi (350 bar)
Nominal Flow	5 gpm (19 l/min)
Internal Leakage	5.5 cu in/min. at 3600 psi and 158 SUS (90 cc/min at 250 bar and 34 cSt)
Fluid Operating Temp. Range	-4° to 248°F (-20° to 120°C) <i>(Consult factory for usage at temp. outside range.)</i>
Ambient Temperature Range	-4° to 140°F (-20° to 60°C)
Coil Duty Rating	Continuous from 85% to 115% of nominal voltage
Current Draw @ 68°F (20°C)	1.5 A at 12VDC; 0.8 A at 24VDC
Min. Pull-in Voltage @ 68°F (20°C)	85% of nominal @ 5000 psi (350 bar)
Fluid Compatibility	Mineral-based or synthetics with lubricating properties
Viscosity	50 to 2000 SUS (7.4 to 420 cSt)
Filtration	21/19/16 or cleaner (per ISO 4406). Use with filter rated $\beta_{10} \geq 200$.
Installation	No orientation restrictions
Cavity	FC08-3 (see <i>Line Bodies & Cavities</i> section)
Cavity Tools	Rougher: 02580086 Finisher: 02580087
Cartridge Weight	0.40 Lbs. (0.18 kg)
Coil Weight	0.42 Lbs. (0.19 kg)
Cartridge Material	Steel with hardened work surfaces. Zinc-plated exposed surfaces. Buna N or Viton® o-rings. PTFE back-up rings.
Coil Material	Class N high temperature magnet wire, steel shell, polyamid encapsulation.
Seal Kits	Buna-N P/N: 03054795 Viton® P/N: 02591059

Performance

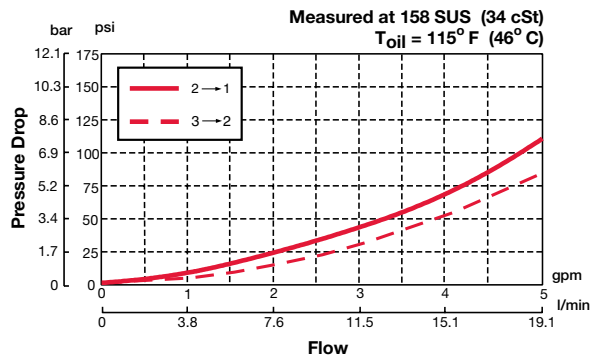

Dimensions

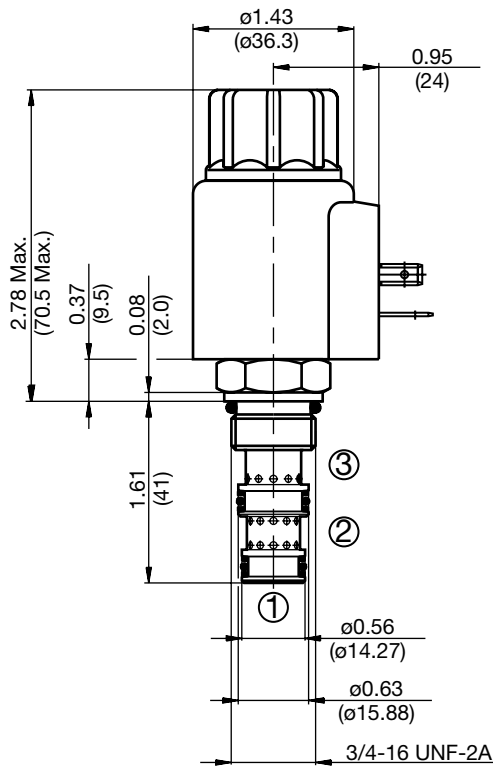
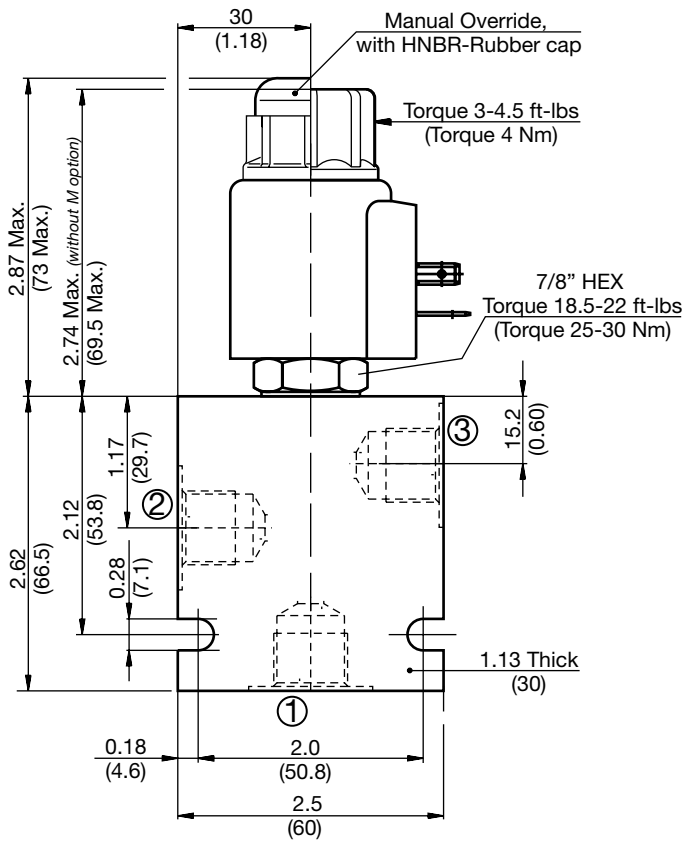

All measurements in inches (mm).
Subject to technical modifications

Model Code

WK08D-01 M-C-N-24 DN

- Valve Model** _____
- Override Option** _____
blank = No manual override
M = Manual override, push type
- Body & Ports** _____
C = Cartridge only
AS6 = SAE-6 Ports, aluminum body
SS6 = SAE-6 Ports, steel body
- Seals** _____
N = Buna-N
V = Viton®
- Coil Voltage** _____
0 = No coil, cartridge only
DC 12 = 12 VDC
24 = 24 VDC
36 = 36 VDC
110 = 110 VDC (only available with connector DG)
- AC 24 = 24 VAC
115 = 115 VAC (AC coils internally full wave rectified)
230 = 230 VAC
- Coil Connector** _____
DC DG = EN 175301-803-A
DS = Dual spade (SAEJ858a)*
DL = Leadwires (2) - 18" long (46 cm)*
DW = WeatherPak™ on leadwires - 9.5" long (24 cm)*
DN = Deutsch™ DT04-2P, molded, axial (IP69K Rated)*
DT = Amp Junior Timer™, molded, radial mount*
- AC AG = EN 175301-803-A

Coil Model 40-1836

For other coil connector types consult factory

*Coils with internal diode are available, consult factory.

Operating Limits

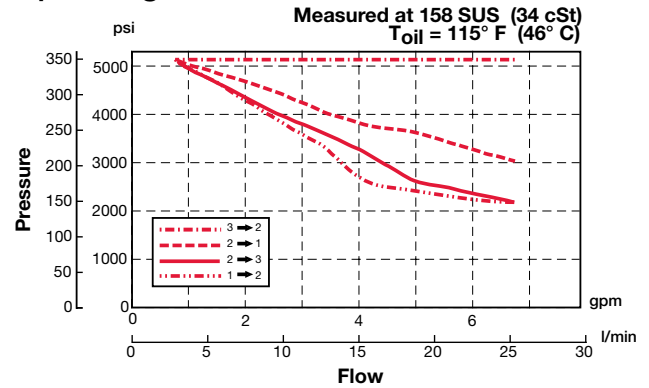

Standard Line Bodies*

Code	Part No	Material	Pressure Rating	Weight
FH083-AS6	03011424	Aluminum, anodized	3500 psi (245 bar)	0.58 lbs (0.26 kg)
FH083-SS6	00560920	Steel, zinc plated	6000 psi (420 bar)	1.7 lbs (0.77 kg)

*Please refer to Line Bodies & Cavities section for details

SOLENOID VALVES

WK10D-01

Spool Type, Direct Acting

Up to 8.4 gpm (32 l/min) • 5000 psi (350 bar)

Hydraulic Symbol

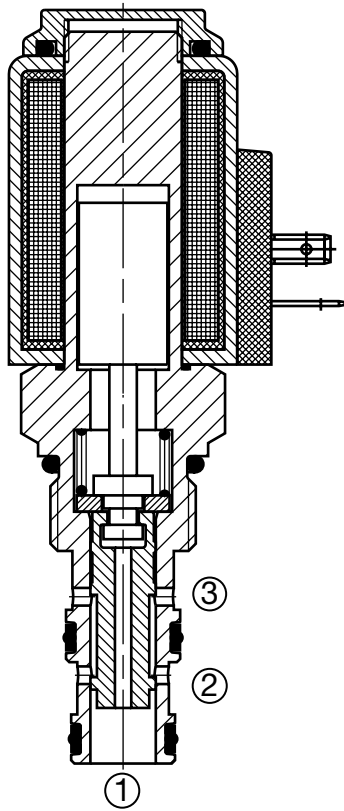
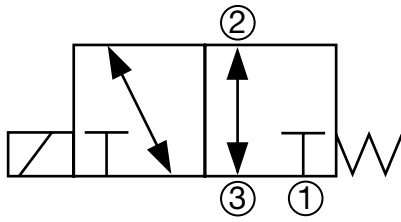

Description

A screw-in cartridge, solenoid operated, 3-way, 2 position, direct acting, spool type valve.

Operation

When de-energized the WK10D allows flow from port 2 to port 3 bi-directionally, while blocking flow at port 1. When energized the spool shifts and opens flow from port 2 to port 1 bi-directionally, while blocking flow at port 3.

Operation of Manual Override Option: To override, remove the coil nut, turn the override knurled knob counterclockwise until it stops. The override will remain activated until the knob is turned clockwise to original position. The manual override option is intended for emergency use, not for continuous duty operation.

Features

- Screw type manual override option

Specifications

Operating Pressure	5000 psi (350 bar)
Nominal Flow	8.4 gpm (32 l/min)
Internal Leakage	7.3 cu in/min. at 3600 psi and 158 SUS (120 cc/min at 250 bar and 34 cSt)
Fluid Operating Temp. Range	-4° to 248°F (-20° to 120°C) (Consult factory for usage at temp. outside range.)
Ambient Temperature Range	-4° to 140°F (-20° to 60°C)
Coil Duty Rating	Continuous from 85% to 115% of nominal voltage
Current Draw @ 68°F (20°C)	2.22 A at 12VDC; 1.13 A at 24VDC
Min. Pull-in Voltage @ 68°F (20°C)	85% of nominal @ 5000 psi (350 bar)
Fluid Compatibility	Mineral-based or synthetics with lubricating properties
Viscosity	50 to 2000 SUS (7.4 to 420 cSt)
Filtration	21/19/16 or cleaner (per ISO 4406). Use with filter rated $\beta_{10} \geq 200$.
Installation	No orientation restrictions
Cavity	FC10-3 (see <i>Line Bodies & Cavities</i> section)
Cavity Tools	Rougher: 02580092 Finisher: 02580093
Cartridge Weight	0.52 Lbs. (0.24 kg)
Coil Weight	0.51 Lbs. (0.23 kg)
Cartridge Material	Steel with hardened work surfaces. Zinc-plated exposed surfaces. Buna N or Viton® o-rings. PTFE back-up rings.
Coil Material	Class N high temperature magnet wire, steel shell, polyamid encapsulation.
Seal Kits	Buna-N P/N: 03071274 Viton® P/N: 03049443

Performance

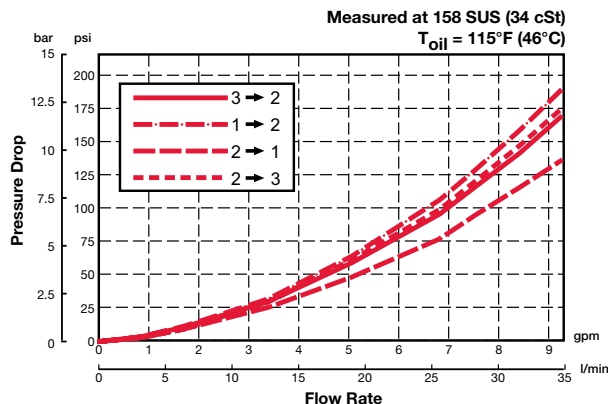

Dimensions

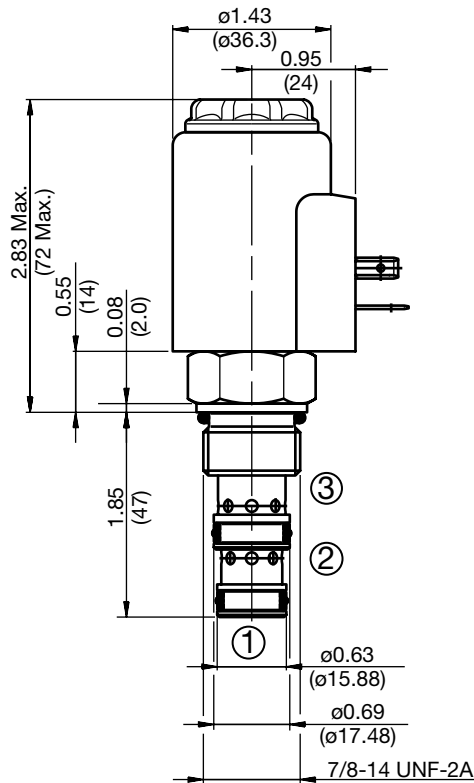
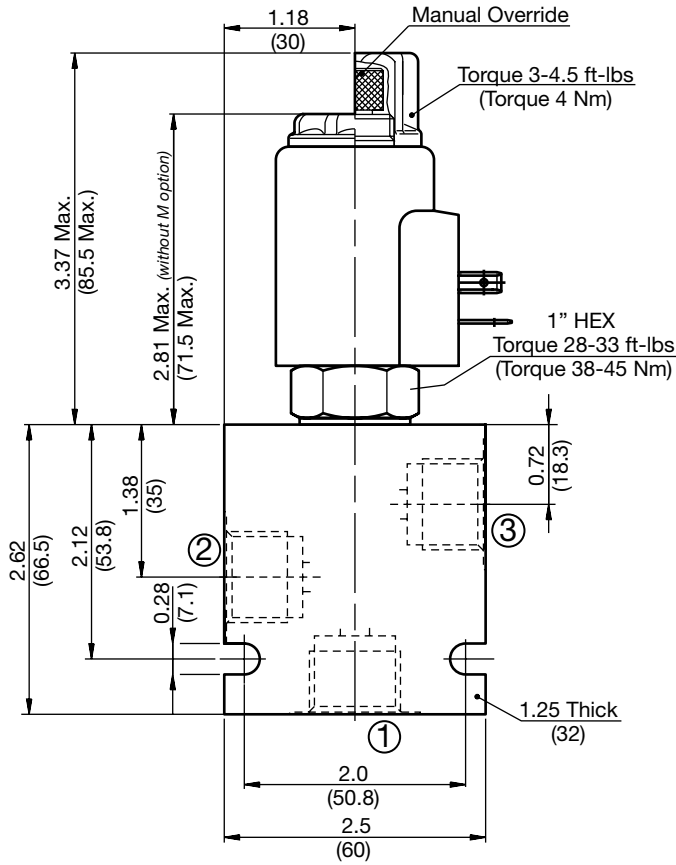

Model Code

WK10D-01 M-C-N-24 DN

Valve Model

Override Option

blank = No manual override
M = Manual override, screw type

Body & Ports

C = Cartridge only
AS8 = SAE-8 Ports, aluminum body
SS8 = SAE-8 Ports, steel body

Seals

N = Buna-N
V = Viton®

Coil Voltage

0 = No coil, cartridge only

DC

12 = 12 VDC
24 = 24 VDC
36 = 36 VDC
110 = 110 VDC (only available with connector DG)

AC

24 = 24 VAC
115 = 115 VAC (AC coils internally full wave rectified)
230 = 230 VAC

Coil Connector

DC DG = EN 175301-803-A
DS = Dual spade (SAEJ858a)*
DL = Leadwires (2) - 18" long (46 cm)*
DW = WeatherPak™ on leadwires - 9.5" long (24 cm)*
DN = Deutsch™ DT04-2P, molded, axial (IP69K Rated)*
DT = Amp Junior Timer™, molded, radial mount*

AC AG = DIN 175301-803

Coil Model 50-1836

For other coil connector types consult factory

*Coils with internal diode are available, consult factory.

Operating Limits

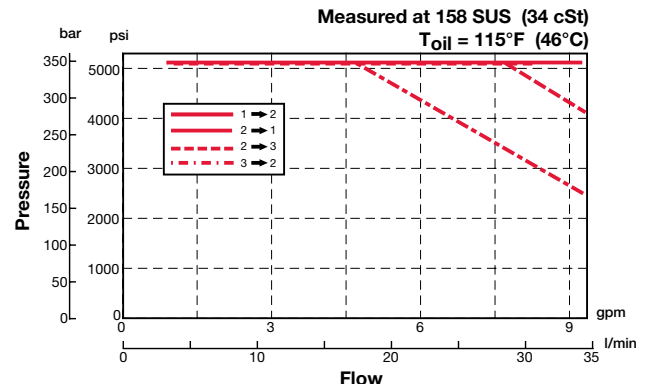

Standard Line Bodies*

Code	Part No	Material	Pressure Rating	Weight
FH103-AS8	03038095	Aluminum, anodized	3500 psi (245 bar)	0.60 lbs (0.27 kg)
FH103-SS8	03037704	Steel, zinc plated	6000 psi (420 bar)	1.74 lbs (0.79 kg)

*Please refer to Line Bodies & Cavities section for details

All measurements in inches (mm).
Subject to technical modifications

SOLENOID VALVES

WK07L-01

Spool Type, Direct Acting

Up to 2.5 gpm (10 l/min) • 5000 psi (350 bar)

Hydraulic Symbol

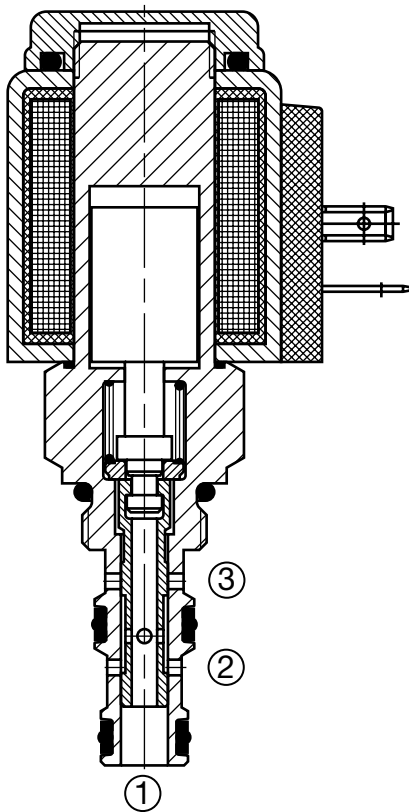
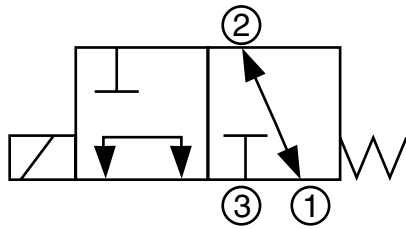

Description

A screw-in cartridge, solenoid operated, 3-way, 2 position, direct acting, spool type valve.

Operation

When de-energized the WK07L allows flow from port 2 to port 1 bi-directionally, while blocking flow at port 3. When energized the spool shifts and opens flow from port 1 to port 3 bi-directionally, while blocking flow at port 2.

Operation of Manual Override Option: To override, remove the coil nut, turn the override knurled knob counterclockwise until it stops. The override will remain activated until the knob is turned clockwise to original position. The manual override option is intended for emergency use, not for continuous duty operation.

Features

- One piece cartridge body design to maximize reliability
- Screw type manual override option

Specifications

Operating Pressure	5000 psi (350 bar)		
Nominal Flow	2.5 gpm at 5000 psi (10 l/min at 350 bar)		
Internal Leakage	4.3 cu in/min. at 3000 psi and 158 SUS (70 cc/min at 280 bar and 34 cSt)		
Fluid Operating Temp. Range	-4° to 248°F (-20° to 120°C) <i>(Consult factory for usage at temp. outside range.)</i>		
Ambient Temperature Range	-4° to 140°F (-20° to 60°C)		
Coil Duty Rating	Continuous from 85% to 115% of nominal voltage		
Current Draw @ 68°F (20°C)	1.5 A at 12VDC; 0.8 A at 24VDC		
Min. Pull-in Voltage @ 68°F (20°C)	85% of nominal @ 5000 psi (350 bar)		
Fluid Compatibility	Mineral-based or synthetics with lubricating properties		
Viscosity	50 to 2000 SUS (7.4 to 420 cSt)		
Filtration	21/19/16 or cleaner (per ISO 4406). Use with filter rated $\beta_{10} \geq 200$.		
Installation	No orientation restrictions		
Cavity	FC07-3 <i>(contact HYDAC for information)</i>		
Cavity Tools	Rougher:	N/A	
	Finisher:	N/A	
Cartridge Weight	0.33 Lbs. (0.15 kg)		
Coil Weight	0.42 Lbs. (0.19 kg)		
Cartridge Material	Steel with hardened work surfaces. Zinc-plated exposed surfaces. Buna N or Viton® o-rings. PTFE back-up rings.		
Coil Material	Class N high temperature magnet wire, steel shell, polyamid encapsulation.		
Seal Kits	Buna-N	FS073-N	P/N: Consult factory
	Viton®	FS073-V	P/N: Consult factory

Performance

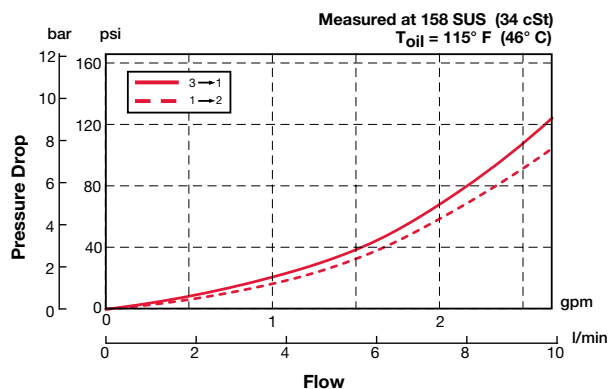

Dimensions

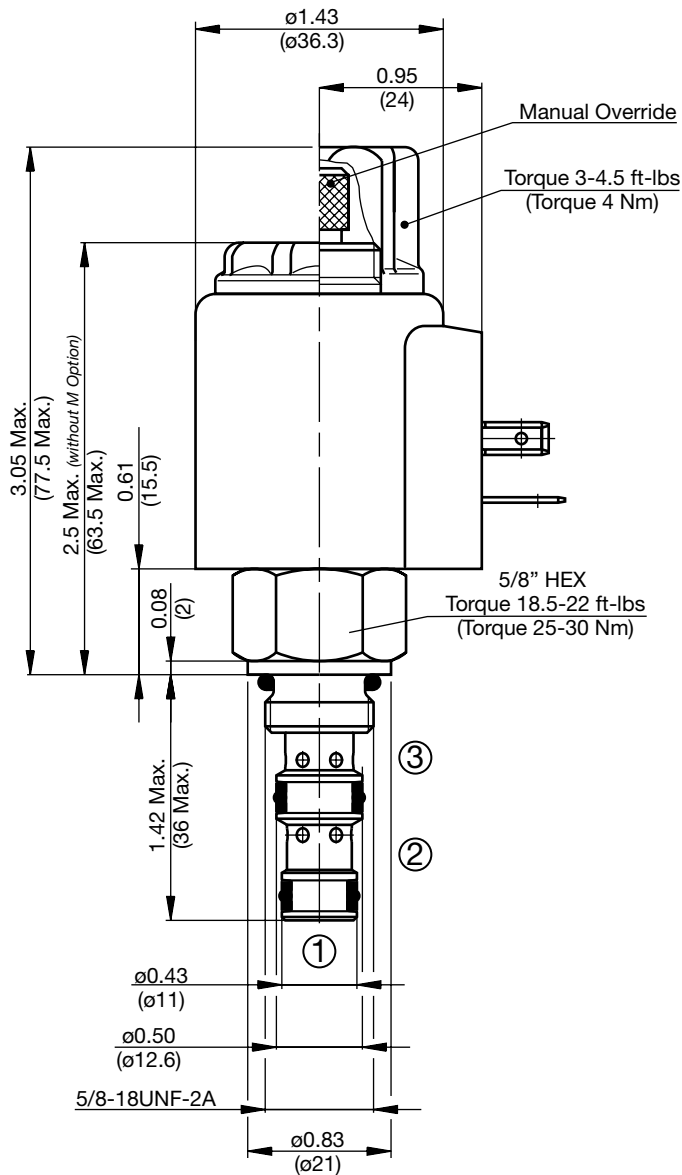

Model Code

WK07L-01 M-C-N-24 DN

Valve Model	_____
Override Option	_____
	blank = No manual override
	M = Manual override, screw type
Body & Ports	_____
	C = Cartridge only
	AS6 = SAE-6 Ports, aluminum body
	SS6 = SAE-6 Ports, steel body
Seals	_____
	N = Buna-N
	V = Viton®
Coil Voltage	_____
	0 = No coil, cartridge only
DC	_____
	12 = 12 VDC
	24 = 24 VDC
	36 = 36 VDC
	110 = 110 VDC (only available with connector DG)
AC	_____
	24 = 24 VAC
	115 = 115 VAC (AC coils internally full wave rectified)
	230 = 230 VAC
Coil Connector	_____
DC	_____
	DG = EN 175301-803-A
	DS = Dual spade (SAEJ858a)*
	DL = Leadwires (2) - 18" long (46 cm)*
	DW = WeatherPak™ on leadwires - 9.5" long (24 cm)*
	DN = Deutsch™ DT04-2P, molded, axial (IP69K Rated)*
	DT = Amp Junior Timer™, molded, radial mount*
AC	AG = EN 175301-803-A

Coil Model 40-1836

For other coil connector types consult factory

*Coils with internal diode are available, consult factory.

SOLENOID VALVES

WK08L-01

Spool Type, Direct Acting

Up to 4.5 gpm (17 l/min) • 5000 psi (350 bar)

Hydraulic Symbol

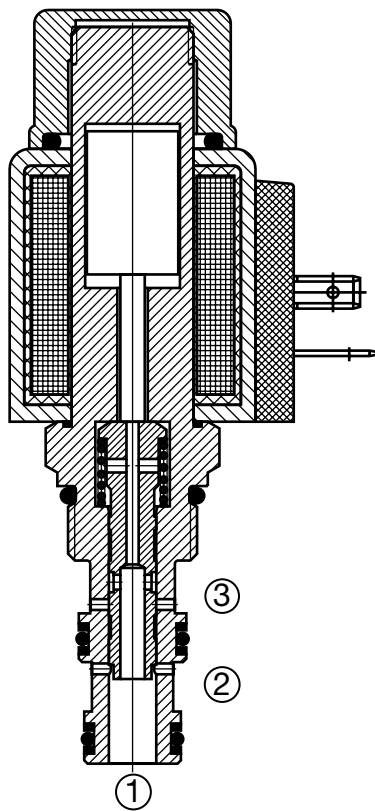
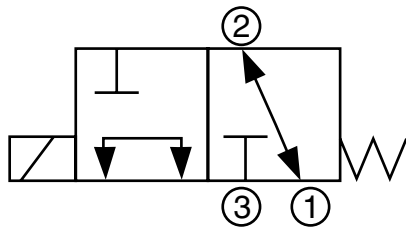

Description

A screw-in cartridge, solenoid operated, 3-way, 2 position, direct acting, spool type valve.

Operation

When de-energized the WK08L allows flow from port 2 to port 1 bi-directionally, while blocking flow at port 3. When energized the spool shifts and opens flow from port 1 to port 3 bi-directionally, while blocking flow at port 2.

Operation of Manual Override Option: To override, push and hold the override button. The override is not detented. The manual override option is intended for emergency use, not for continuous duty operation.

Features

- Push type manual override button, protected by rubber cap

Specifications

Operating Pressure	5000 psi (350 bar)
Nominal Flow	4.5 gpm (17 l/min)
Internal Leakage	5.5 cu in/min. at 3600 psi and 158 SUS (90 cc/min at 250 bar and 34 cSt)
Fluid Operating Temp. Range	-4° to 248°F (-20° to 120°C) <i>(Consult factory for usage at temp. outside range.)</i>
Ambient Temperature Range	-4° to 140°F (-20° to 60°C)
Coil Duty Rating	Continuous from 85% to 115% of nominal voltage
Current Draw @ 68°F (20°C)	1.5 A at 12VDC; 0.8 A at 24VDC
Min. Pull-in Voltage @ 68°F (20°C)	85% of nominal @ 5000 psi (350 bar)
Fluid Compatibility	Mineral-based or synthetics with lubricating properties
Viscosity	50 to 2000 SUS (7.4 to 420 cSt)
Filtration	21/19/16 or cleaner (per ISO 4406). Use with filter rated B10 ≥ 200.
Installation	No orientation restrictions
Cavity	FC08-3 <i>(see Line Bodies & Cavities section)</i>
Cavity Tools	Rougher: 02580086 Finisher: 02580087
Cartridge Weight	0.40 Lbs. (0.18 kg)
Coil Weight	0.42 Lbs. (0.19 kg)
Cartridge Material	Steel with hardened work surfaces. Zinc-plated exposed surfaces. Buna N or Viton® o-rings. PTFE back-up rings.
Coil Material	Class N high temperature magnet wire, steel shell, polyamid encapsulation.
Seal Kits	Buna-N P/N: 03054795 Viton® P/N: 02591059

Performance

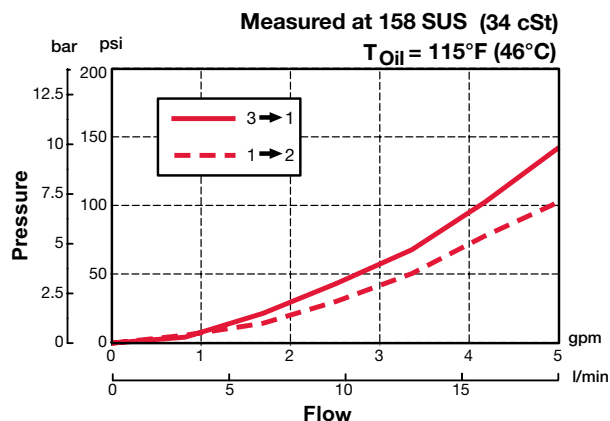

Dimensions

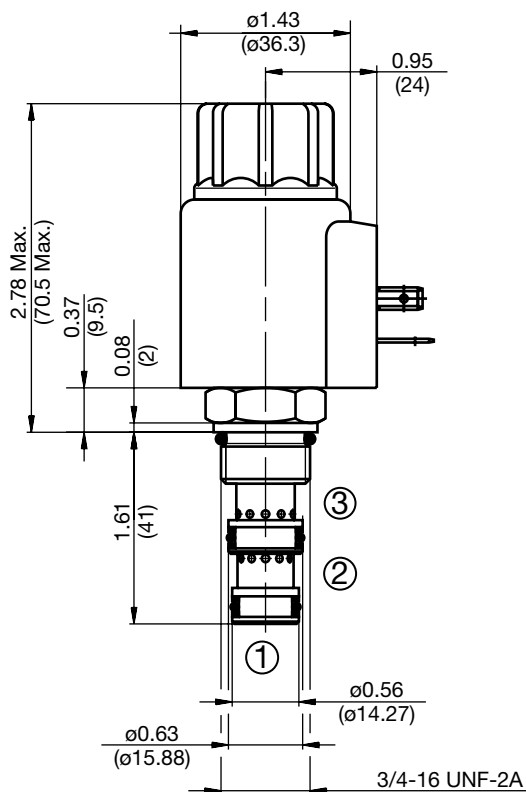
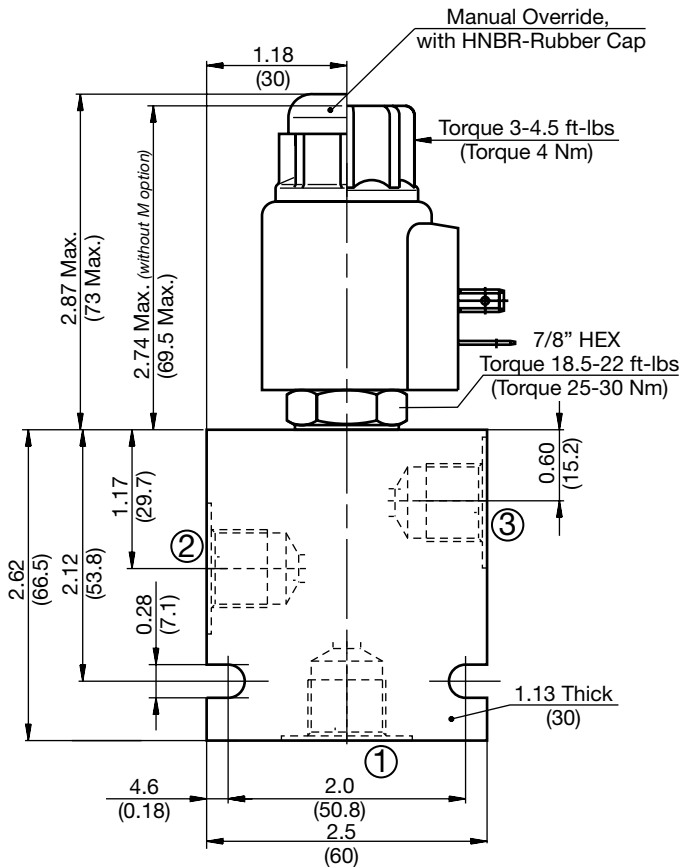

All measurements in inches (mm).
Subject to technical modifications

Model Code

WK08L-01 M-C-N-24 DN

- Valve Model** _____
- Override Option** _____
 blank = No manual override
 M = Manual override, push type
- Body & Ports** _____
 C = Cartridge only
 AS6 = SAE-6 Ports, aluminum body
 SS6 = SAE-6 Ports, steel body
- Seals** _____
 N = Buna-N
 V = Viton®
- Coil Voltage** _____
 0 = No coil, cartridge only
- DC** _____
 12 = 12 VDC
 24 = 24 VDC
 36 = 36 VDC
 110 = 110 VDC (only available with connector DG)
- AC** _____
 24 = 24 VAC
 115 = 115 VAC (AC coils internally full wave rectified)
 230 = 230 VAC
- Coil Connector** _____
 DC _____
 DG = EN 175301-803-A
 DS = Dual spade (SAEJ858a)*
 DL = Leadwires (2) - 18" long (46 cm)*
 DW = WeatherPak™ on leadwires - 9.5" long (24 cm)*
 DN = Deutsch™ DT04-2P, molded, axial (IP69K Rated)*
 DT = Amp Junior Timer™, molded, radial mount*
- AC AG** = EN 175301-803-A

Coil Model 40-1836

For other coil connector types consult factory

*Coils with internal diode are available, consult factory.

Operating Limits

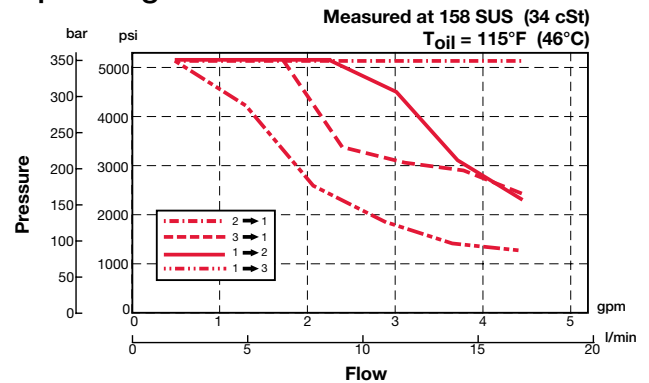

Standard Line Bodies*

Code	Part No	Material	Pressure Rating	Weight
FH083-AS6	03011424	Aluminum, anodized	3500 psi (245 bar)	0.58 lbs (0.26 kg)
FH083-SS6	00560920	Steel, zinc plated	6000 psi (420 bar)	1.7 lbs (0.77 kg)

*Please refer to Line Bodies & Cavities section for details

SOLENOID VALVES

WK10L-01

Spool Type, Direct Acting

Up to 8.4 gpm (32 l/min) • 5000 psi (350 bar)

Hydraulic Symbol

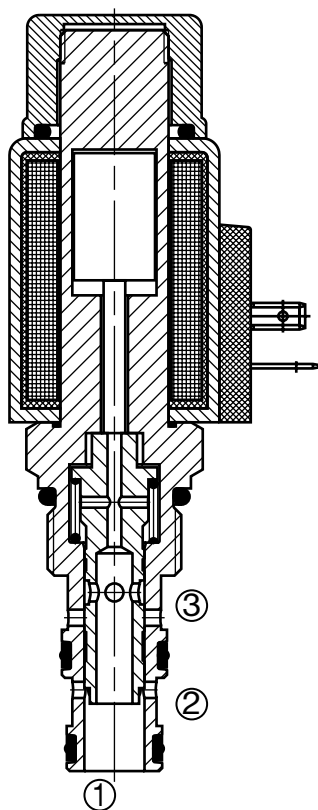
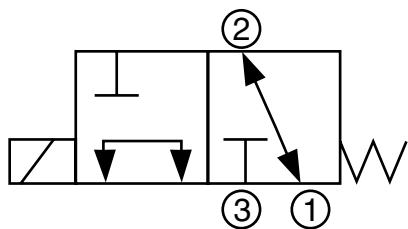

Description

A screw-in cartridge, solenoid operated, 3-way, 2 position, direct acting, spool type valve.

Operation

When de-energized the WK10L allows flow from port 2 to port 1 bi-directionally, while blocking flow at port 3. When energized the spool shifts and opens flow from port 1 to port 3 bi-directionally, while blocking flow at port 2.

Operation of Manual Override Option: To override, push and hold the override button. The override is not detented. The manual override option is intended for emergency use, not for continuous duty operation.

Features

- One piece cartridge body design to maximize reliability
- Push type manual override button, protected by rubber cap

Specifications

Operating Pressure	5000 psi (350 bar)
Nominal Flow	8.4 gpm (32 l/min)
Internal Leakage	6 cu in/min. at 3600 psi and 158 SUS (100 cc/min at 250 bar and 34 cSt)
Fluid Operating Temp. Range	-4° to 248°F (-20° to 120°C) <i>(Consult factory for usage at temp. outside range.)</i>
Ambient Temperature Range	-4° to 140°F (-20° to 60°C)
Coil Duty Rating	Continuous from 85% to 115% of nominal voltage
Current Draw @ 68°F (20°C)	2.22 A at 12VDC; 1.13 A at 24VDC
Min. Pull-in Voltage @ 68°F (20°C)	85% of nominal @ 5000 psi (350 bar)
Fluid Compatibility	Mineral-based or synthetics with lubricating properties
Viscosity	50 to 2000 SUS (7.4 to 420 cSt)
Filtration	21/19/16 or cleaner (per ISO 4406). Use with filter rated B10 ≥ 200.
Installation	No orientation restrictions
Cavity	FC10-3 <i>(see Line Bodies & Cavities section)</i>
Cavity Tools	Rougher: 02580092 Finisher: 02580093
Cartridge Weight	0.52 Lbs. (0.24 kg)
Coil Weight	0.51 Lbs. (0.23 kg)
Cartridge Material	Steel with hardened work surfaces. Zinc-plated exposed surfaces. Buna N or Viton® o-rings. PTFE back-up rings.
Coil Material	Class N high temperature magnet wire, steel shell, polyamid encapsulation.
Seal Kits	Buna-N P/N: 03071274 Viton® P/N: 03049443

Performance

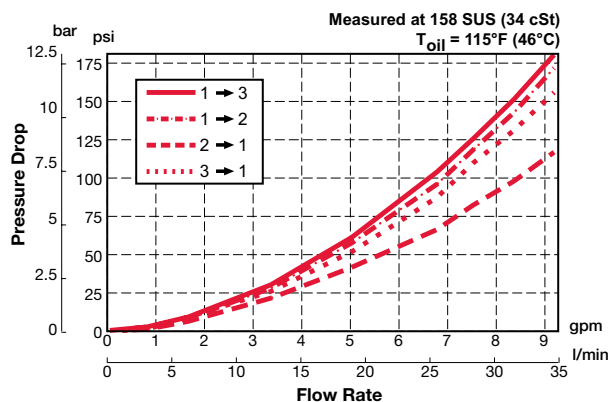

Dimensions

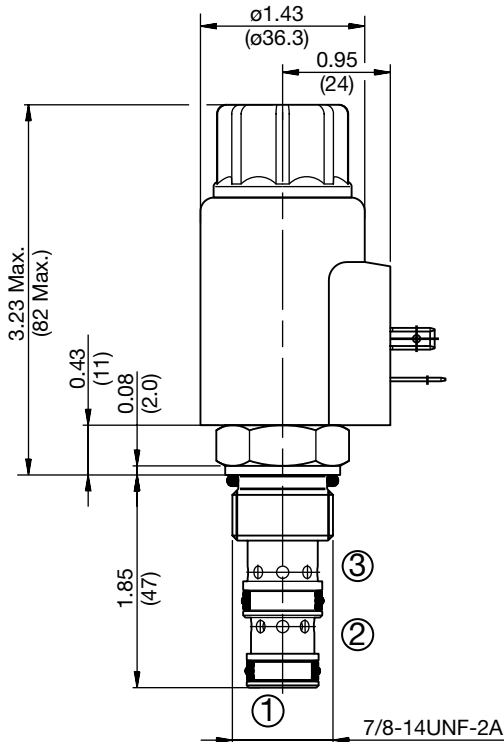
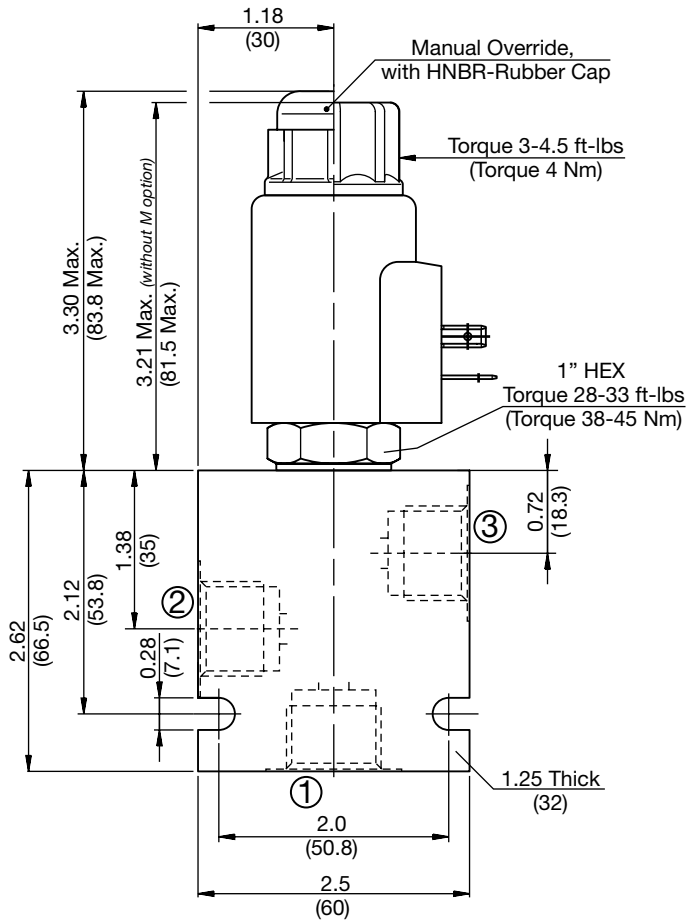

All measurements in inches (mm).
Subject to technical modifications

PN#02087369 / 10.19 / CHD1110-1389

Model Code

WK10L-01 M-C-N-24 DN

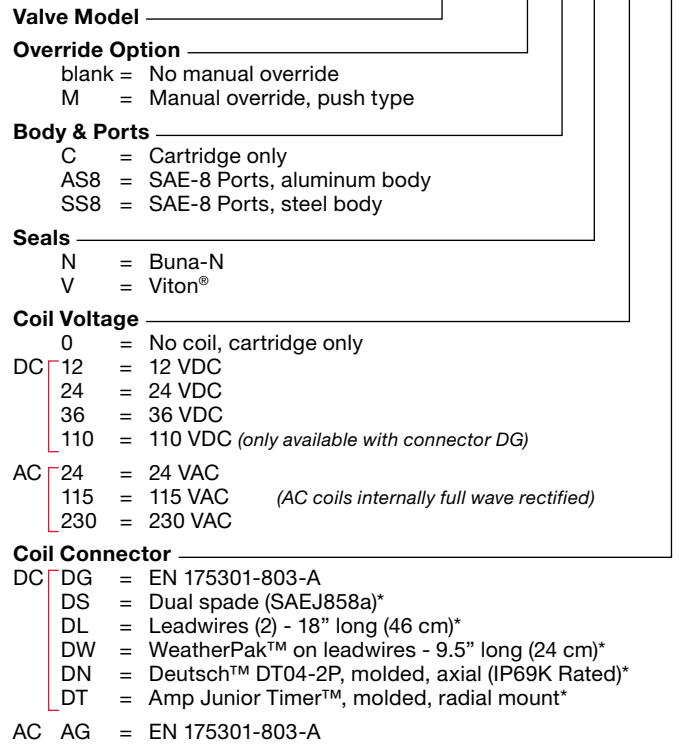

Coil Model 50-1836

For other coil connector types consult factory

*Coils with internal diode are available, consult factory.

Operating Limits

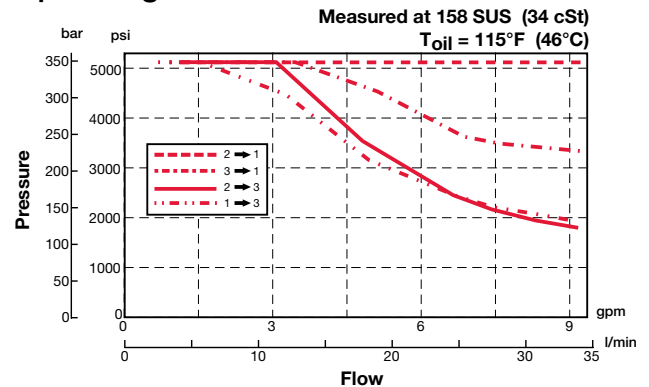

Standard Line Bodies*

Code	Part No	Material	Pressure Rating	Weight
FH103-AS8	03038095	Aluminum, anodized	3500 psi (245 bar)	0.60 lbs (0.27 kg)
FH103-SS8	03037704	Steel, zinc plated	6000 psi (420 bar)	1.74 lbs (0.79 kg)

*Please refer to Line Bodies & Cavities section for details

SOLENOID VALVES

WK08A-01

Spool Type, Direct Acting

Up to 5 gpm (19 l/min) • 5000 psi (350 bar)

Hydraulic Symbol

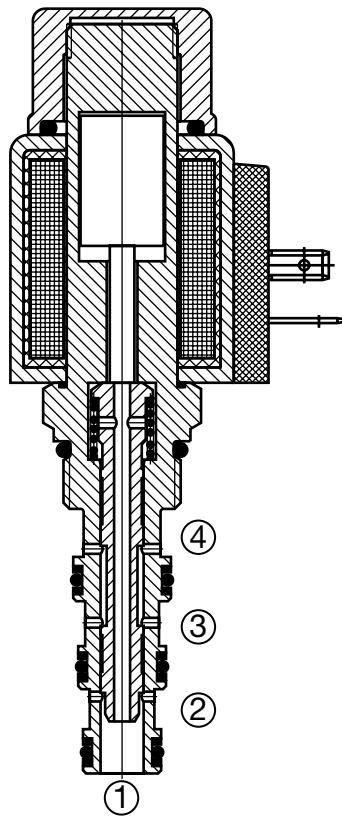
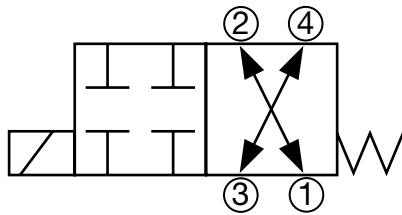

Description

A screw-in cartridge, solenoid operated, 4-way, 2 position, direct acting, spool type valve.

Operation

When de-energized the WK08A allows flow from port 2 to port 1 bi-directionally and port 3 to port 4 bi-directionally. When energized the spool shifts and blocks all ports.

Operation of Manual Override Option: To override, push and hold the override button. The override is not detented. The manual override option is intended for emergency use, not for continuous duty operation.

Features

- Push type manual override button, protected by rubber cap

Specifications

Operating Pressure	5000 psi (350 bar)
Nominal Flow	5 gpm at 3600 psi (19 l/min at 250 bar) 2 gpm at 5000 psi (7.6 l/min at 350 bar)
Internal Leakage	5.5 cu in/min. at 3600 psi and 158 SUS (90 cc/min at 250 bar and 34 cSt)
Fluid Operating Temp. Range	-4° to 248°F (-20° to 120°C) (Consult factory for usage at temp. outside range.)
Ambient Temperature Range	-4° to 140°F (-20° to 60°C)
Coil Duty Rating	Continuous from 85% to 115% of nominal voltage
Current Draw @ 68°F (20°C)	1.5 A at 12VDC; 0.8 A at 24VDC
Min. Pull-in Voltage @ 68°F (20°C)	85% of nominal @ 5000 psi (350 bar)
Fluid Compatibility	Mineral-based or synthetics with lubricating properties
Viscosity	50 to 2000 SUS (7.4 to 420 cSt)
Filtration	21/19/16 or cleaner (per ISO 4406). Use with filter rated $\beta_{10} \geq 200$.
Installation	No orientation restrictions
Cavity	FC08-4 (see <i>Line Bodies & Cavities</i> section)
Cavity Tools	Rougher: 02580088 Finisher: 02580089
Cartridge Weight	0.42 Lbs. (0.19 kg)
Coil Weight	0.42 Lbs. (0.19 kg)
Cartridge Material	Steel with hardened work surfaces. Zinc-plated exposed surfaces. Buna N or Viton® o-rings. PTFE back-up rings.
Coil Material	Class N high temperature magnet wire, steel shell, polyamid encapsulation.
Seal Kits	Buna-N P/N: 03071272 Viton® P/N: 03071273

Performance

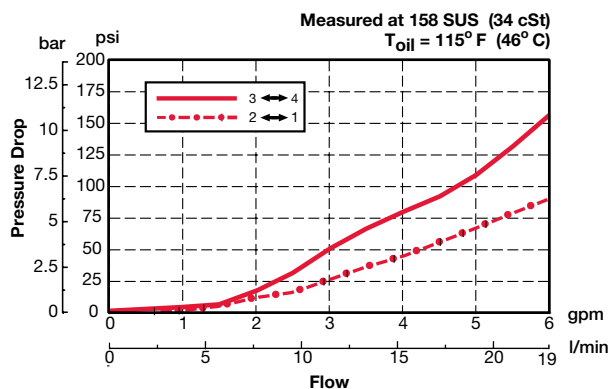

Dimensions

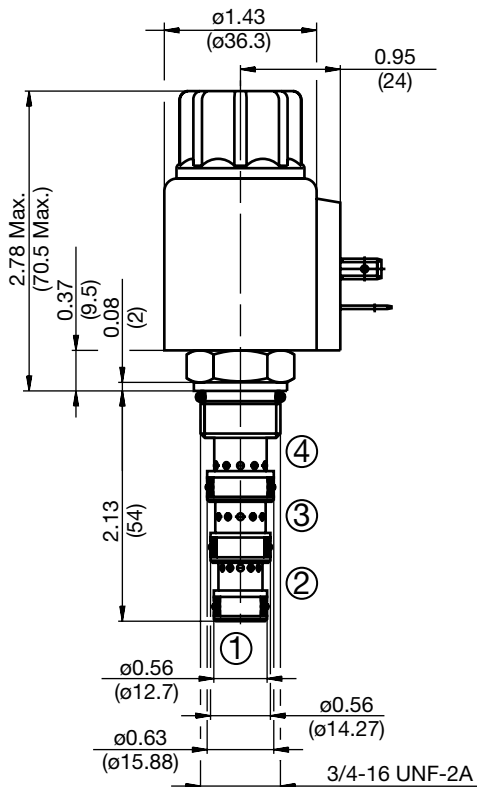
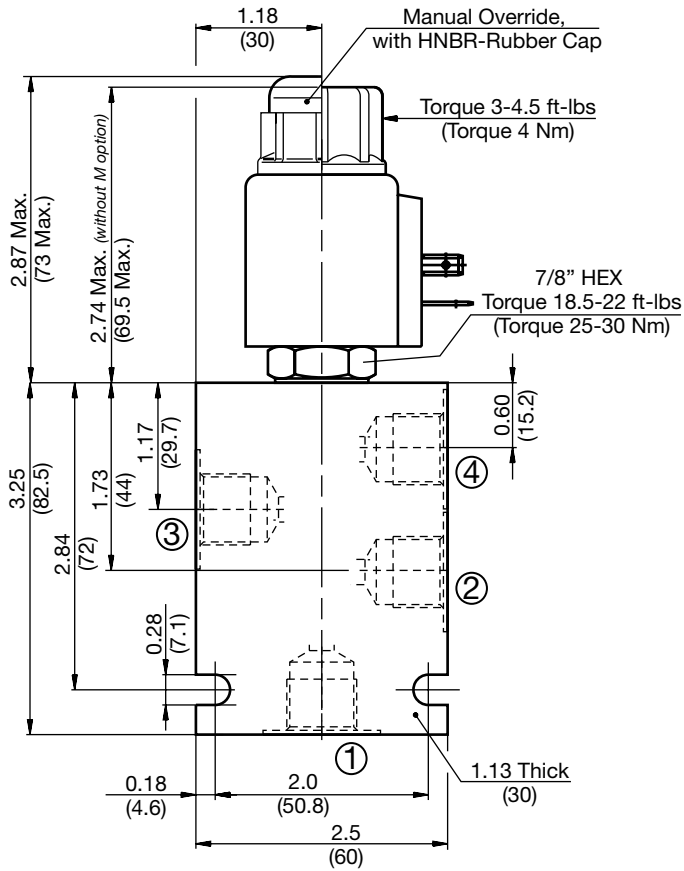

All measurements in inches (mm).
Subject to technical modifications

Model Code

WK08A-01 M-C-N-24 DN

Valve Model _____

Override Option _____
 blank = No manual override
 M = Manual override, push type

Body & Ports _____
 C = Cartridge only
 AS6 = SAE-6 Ports, aluminum body
 SS6 = SAE-6 Ports, steel body

Seals _____
 N = Buna-N
 V = Viton®

Coil Voltage _____
 0 = No coil, cartridge only

DC _____
 12 = 12 VDC
 24 = 24 VDC
 36 = 36 VDC
 110 = 110 VDC (only available with connector DG)

AC _____
 24 = 24 VAC
 115 = 115 VAC (AC coils internally full wave rectified)
 230 = 230 VAC

Coil Connector _____
 DC DG = EN 175301-803-A
 DS = Dual spade (SAEJ858a)*
 DL = Leadwires (2) - 18" long (46 cm)*
 DW = WeatherPak™ on leadwires - 9.5" long (24 cm)*
 DN = Deutsch™ DT04-2P, molded, axial (IP69K Rated)*
 DT = Amp Junior Timer™, molded, radial mount*

AC AG = EN 175301-803-A

Coil Model 40-1836
 For other coil connector types consult factory

*Coils with internal diode are available, consult factory.

Standard Line Bodies*

Code	Part No	Material	Pressure Rating	Weight
FH084-AS6	03011404	Aluminum, anodized	3500 psi (245 bar)	0.72 lbs (0.33 kg)
FH084-SS6	00563381	Steel, zinc plated	6000 psi (420 bar)	2.12 lbs (0.96 kg)

*Please refer to Line Bodies & Cavities section for details

SOLENOID VALVES

WK10A-01

Spool Type, Direct Acting

Up to 8.4 gpm (32 l/min) • 5000 psi (350 bar)

Hydraulic Symbol

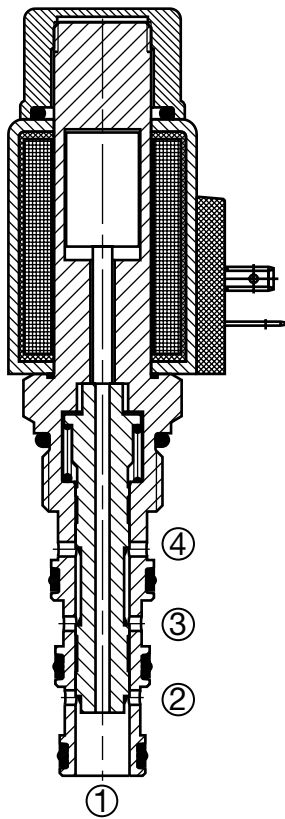
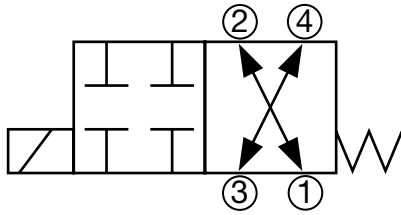

Description

A screw-in cartridge, solenoid operated, 4-way, 2 position, direct acting, spool type valve.

Operation

When de-energized the WK10A allows flow from port 3 to port 4 bi-directionally and port 2 to port 1 bi-directionally. When energized the spool shifts and blocks flow at all ports.

Operation of Manual Override Option: To override, push and hold the override button. The override is not detented. The manual override option is intended for emergency use, not for continuous duty operation.

Features

- Push type manual override button, protected by rubber cap

Specifications

Operating Pressure	5000 psi (350 bar)
Nominal Flow	8.4 gpm at 5000 psi (32 l/min at 350 bar)
Internal Leakage	7.3 cu in/min. at 3600 psi and 158 SUS (120 cc/min at 250 bar and 34 cSt)
Fluid Operating Temp. Range	-4° to 248°F (-20° to 120°C) <i>(Consult factory for usage at temp. outside range.)</i>
Ambient Temperature Range	-4° to 140°F (-20° to 60°C)
Coil Duty Rating	Continuous from 85% to 115% of nominal voltage
Current Draw @ 68°F (20°C)	2.22 A at 12VDC; 1.13 A at 24VDC
Min. Pull-in Voltage @ 68°F (20°C)	85% of nominal @ 5000 psi (350 bar)
Fluid Compatibility	Mineral-based or synthetics with lubricating properties
Viscosity	50 to 2000 SUS (7.4 to 420 cSt)
Filtration	21/19/16 or cleaner (per ISO 4406). Use with filter rated $\beta_{10} \geq 200$.
Installation	No orientation restrictions
Cavity	FC10-4 (see <i>Line Bodies & Cavities</i> section)
Cavity Tools	Rougher: 02580248 Finisher: 02580249
Cartridge Weight	0.55 Lbs. (0.25 kg)
Coil Weight	0.51 Lbs. (0.23 kg)
Cartridge Material	Steel with hardened work surfaces. Zinc-plated exposed surfaces. Buna N or Viton® o-rings. PTFE back-up rings.
Coil Material	Class N high temperature magnet wire, steel shell, polyamid encapsulation.
Seal Kits	Buna-N P/N: 03051912 Viton® FS104-V P/N: 03071275

Performance

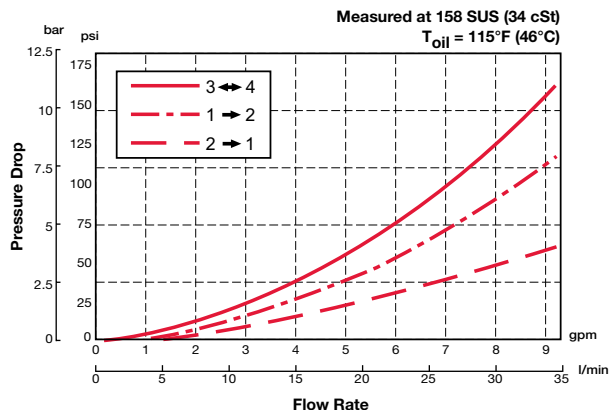

Dimensions

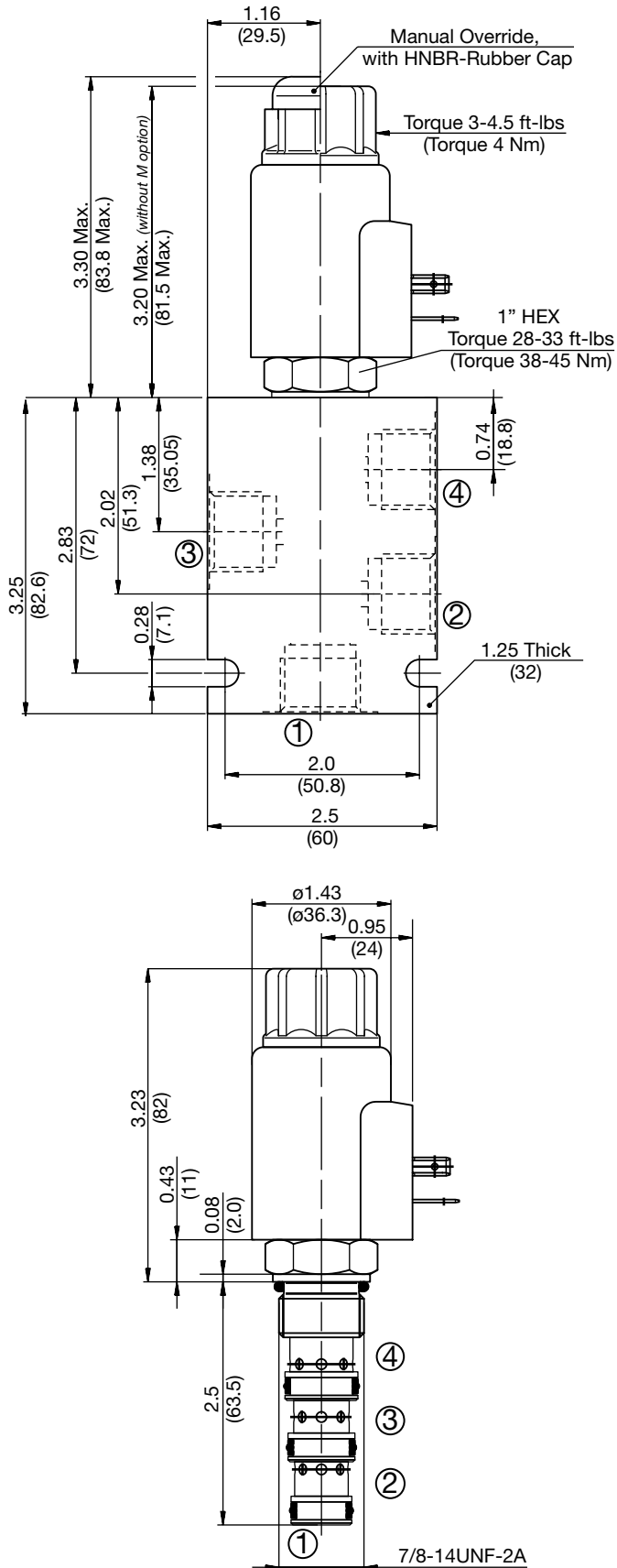

Model Code

WK10A-01 M-C-N-24 DN

- Valve Model** _____
- Override Option** _____
 blank = No manual override
 M = Manual override, push type
- Body & Ports** _____
 C = Cartridge only
 AS8 = SAE-8 Ports, aluminum body
 SS8 = SAE-8 Ports, steel body
- Seals** _____
 N = Buna-N
 V = Viton®
- Coil Voltage** _____
 0 = No coil, cartridge only
- DC** _____
 12 = 12 VDC
 24 = 24 VDC
 36 = 36 VDC
 110 = 110 VDC (only available with connector DG)
- AC** _____
 24 = 24 VAC
 115 = 115 VAC (AC coils internally full wave rectified)
 230 = 230 VAC
- Coil Connector** _____
 DC DG = EN 175301-803-A
 DS = Dual spade (SAEJ858a)*
 DL = Leadwires (2) - 18" long (46 cm)*
 DW = WeatherPak™ on leadwires - 9.5" long (24 cm)*
 DN = Deutsch™ DT04-2P, molded, axial (IP69K Rated)*
 DT = Amp Junior Timer™, molded, radial mount*
- AC AG = EN 175301-803-A

Coil Model 50-1836

For other coil connector types consult factory

*Coils with internal diode are available, consult factory.

All measurements in inches (mm).
Subject to technical modifications

Standard Line Bodies*

Code	Part No	Material	Pressure Rating	Weight
FH104-AS8	03038110	Aluminum, anodized	3500 psi (245 bar)	0.72 lbs (0.33 kg)
FH104-SS8	03037868	Steel, zinc plated	6000 psi (420 bar)	2.12 lbs (0.96 kg)

*Please refer to Line Bodies & Cavities section for details

SOLENOID VALVES

WK08K-01

Spool Type, Direct Acting

Up to 4 gpm (15 l/min) • 5000 psi (350 bar)

Hydraulic Symbol

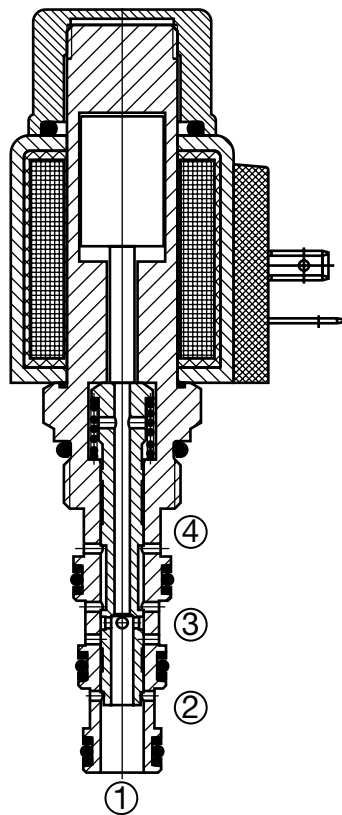
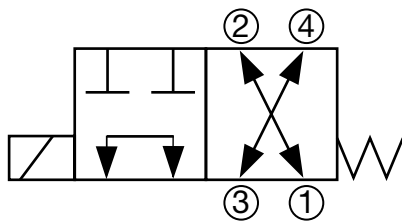

Description

A screw-in cartridge, solenoid operated, 4-way, 2 position, direct acting, spool type valve.

Operation

When de-energized the WK08K allows flow from port 2 to port 1 bi-directionally and port 3 to port 4 bi-directionally. When energized the spool shifts and allows flow from port 1 to port 3 bi-directionally, ports 2 and 4 are blocked.

Operation of Manual Override Option: To override, push and hold the override button. The override is not detented. The manual override option is intended for emergency use, not for continuous duty operation.

Features

- Push type manual override button, protected by rubber cap

Specifications

Operating Pressure	5000 psi (350 bar)
Nominal Flow	4 gpm at 3600 psi (15 l/min at 250 bar) 2 gpm at 5000 psi (7.6 l/min at 350 bar)
Internal Leakage	5 cu in/min. at 3600 psi and 158 SUS (82 cc/min at 250 bar and 34 cSt)
Fluid Operating Temp. Range	-4° to 248°F (-20° to 120°C) (Consult factory for usage at temp. outside range.)
Ambient Temperature Range	-4° to 140°F (-20° to 60°C)
Coil Duty Rating	Continuous from 85% to 115% of nominal voltage
Current Draw @ 68°F (20°C)	1.5 A at 12VDC; 0.8 A at 24VDC
Min. Pull-in Voltage @ 68°F (20°C)	85% of nominal @ 5000 psi (350 bar)
Fluid Compatibility	Mineral-based or synthetics with lubricating properties
Viscosity	50 to 2000 SUS (7.4 to 420 cSt)
Filtration	21/19/16 or cleaner (per ISO 4406). Use with filter rated $\beta_{10} \geq 200$.
Installation	No orientation restrictions
Cavity	FC08-4 (see <i>Line Bodies & Cavities</i> section)
Cavity Tools	Rougher: 02580088 Finisher: 02580089
Cartridge Weight	0.42 Lbs. (0.19 kg)
Coil Weight	0.42 Lbs. (0.19 kg)
Cartridge Material	Steel with hardened work surfaces. Zinc-plated exposed surfaces. Buna N or Viton® o-rings. PTFE back-up rings.
Coil Material	Class N high temperature magnet wire, steel shell, polyamid encapsulation.
Seal Kits	Buna-N P/N: 03071272 Viton® P/N: 03071273

Performance

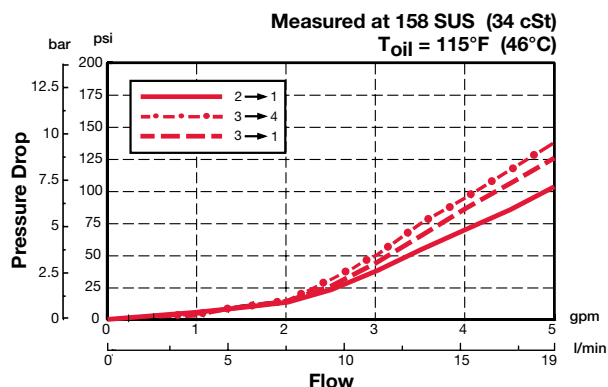

Dimensions

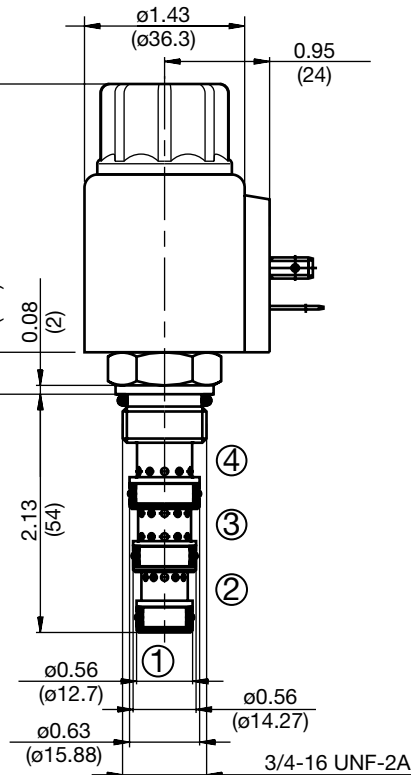
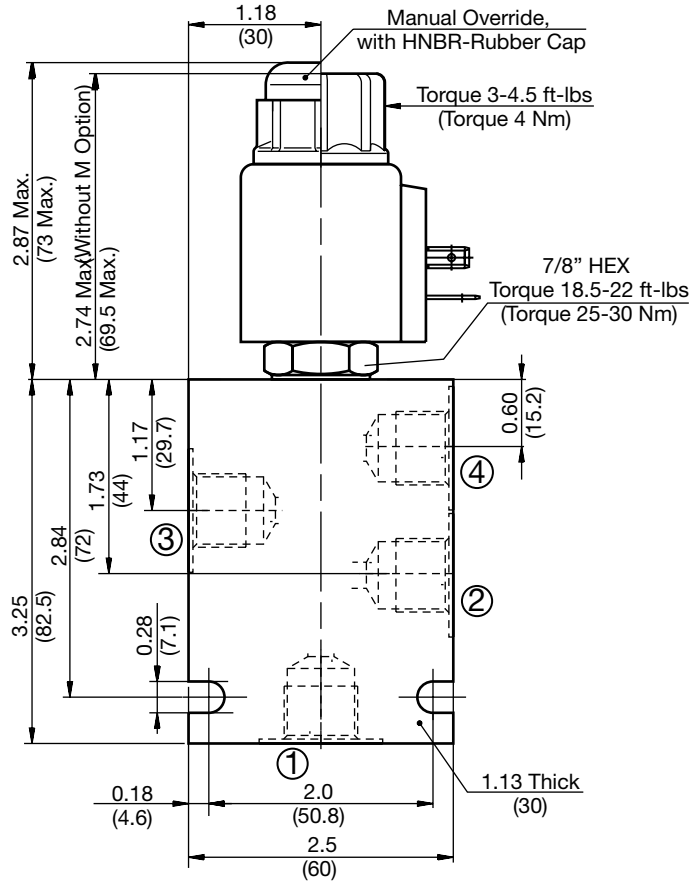

Model Code

WK08K-01 M-C-N-24 DN

Valve Model

Override Option

- blank = No manual override
- M = Manual override, push type

Body & Ports

- C = Cartridge only
- AS6 = SAE-6 Ports, aluminum body
- SS6 = SAE-6 Ports, steel body

Seals

- N = Buna-N
- V = Viton®

Coil Voltage

- 0 = No coil, cartridge only
- DC 12 = 12 VDC
- 24 = 24 VDC
- 36 = 36 VDC
- 110 = 110 VDC (only available with connector DG)
- AC 24 = 24 VAC
- 115 = 115 VAC (AC coils internally full wave rectified)
- 230 = 230 VAC

Coil Connector

- DC DG = EN 175301-803-A
- DS = Dual spade (SAEJ858a)*
- DL = Leadwires (2) - 18" long (46 cm)*
- DW = WeatherPak™ on leadwires - 9.5" long (24 cm)*
- DN = Deutsch™ DT04-2P, molded, axial (IP69K Rated)*
- DT = Amp Junior Timer™, molded, radial mount*
- AC AG = EN 175301-803-A

Coil Model 40-1836

For other coil connector types consult factory

*Coils with internal diode are available, consult factory.

All measurements in inches (mm).
Subject to technical modifications

PN#02087369 / 10.19 / CHD1110-1389

Standard Line Bodies*

Code	Part No	Material	Pressure Rating	Weight
FH084-AS6	03011404	Aluminum, anodized	3500 psi (245 bar)	0.72 lbs (0.33 kg)
FH084-SS6	00563381	Steel, zinc plated	6000 psi (420 bar)	2.12 lbs (0.96 kg)

*Please refer to Line Bodies & Cavities section for details

SOLENOID VALVES

WK10K-01

Spool Type, Direct Acting

Up to 8.4 gpm (32 l/min) • 5000 psi (350 bar)

Hydraulic Symbol

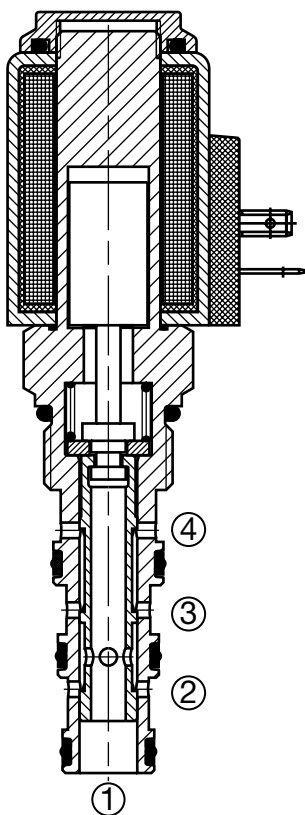
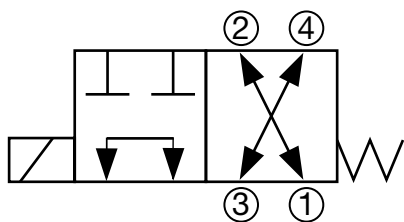

Description

A screw-in cartridge, solenoid operated, 4-way, 2 position, direct acting, spool type valve.

Operation

When de-energized the WK10K allows flow from port 1 to port 2 bi-directionally and from port 3 to port 4 bi-directionally. When energized the spool shifts and allows flow from port 1 to port 3 bi-directionally, ports 2 and 4 are blocked.

Operation of Manual Override Option: To override, remove the coil nut, turn the override knurled knob counterclockwise until it stops. The override will remain activated until the knob is turned clockwise to original position. The manual override option is intended for emergency use, not for continuous duty operation.

Features

- Screw type manual override

Specifications

Operating Pressure	5000 psi (350 bar)
Nominal Flow	8.4 gpm at 5000 psi (32 l/min at 350 bar)
Internal Leakage	7.3 cu in/min. at 3600 psi and 158 SUS (120 cc/min at 250 bar and 34 cSt)
Fluid Operating Temp. Range	-4° to 248°F (-20° to 120°C) (Consult factory for usage at temp. outside range.)
Ambient Temperature Range	-4° to 140°F (-20° to 60°C)
Coil Duty Rating	Continuous from 85% to 115% of nominal voltage
Current Draw @ 68°F (20°C)	2.22 A at 12VDC; 1.13 A at 24VDC
Min. Pull-in Voltage @ 68°F (20°C)	85% of nominal @ 5000 psi (350 bar)
Fluid Compatibility	Mineral-based or synthetics with lubricating properties
Viscosity	50 to 2000 SUS (7.4 to 420 cSt)
Filtration	21/19/16 or cleaner (per ISO 4406). Use with filter rated $\beta_{10} \geq 200$.
Installation	No orientation restrictions
Cavity	FC10-4 (see <i>Line Bodies & Cavities</i> section)
Cavity Tools	Rougher: 02580248 Finisher: 02580249
Cartridge Weight	0.55 Lbs. (0.25 kg)
Coil Weight	0.51 Lbs. (0.23 kg)
Cartridge Material	Steel with hardened work surfaces. Zinc-plated exposed surfaces. Buna N or Viton® o-rings. PTFE back-up rings.
Coil Material	Class N high temperature magnet wire, steel shell, polyamid encapsulation.
Seal Kits	Buna-N P/N: 03051912 Viton® P/N: 03071275

Performance

Measured at 158 SUS (34 cSt)
 $T_{oil} = 115^{\circ}\text{F} (46^{\circ}\text{C})$

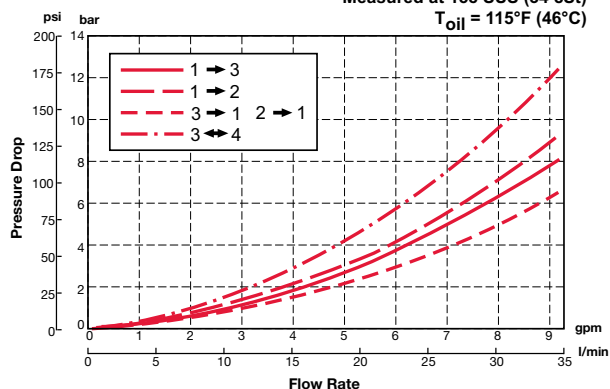

Dimensions

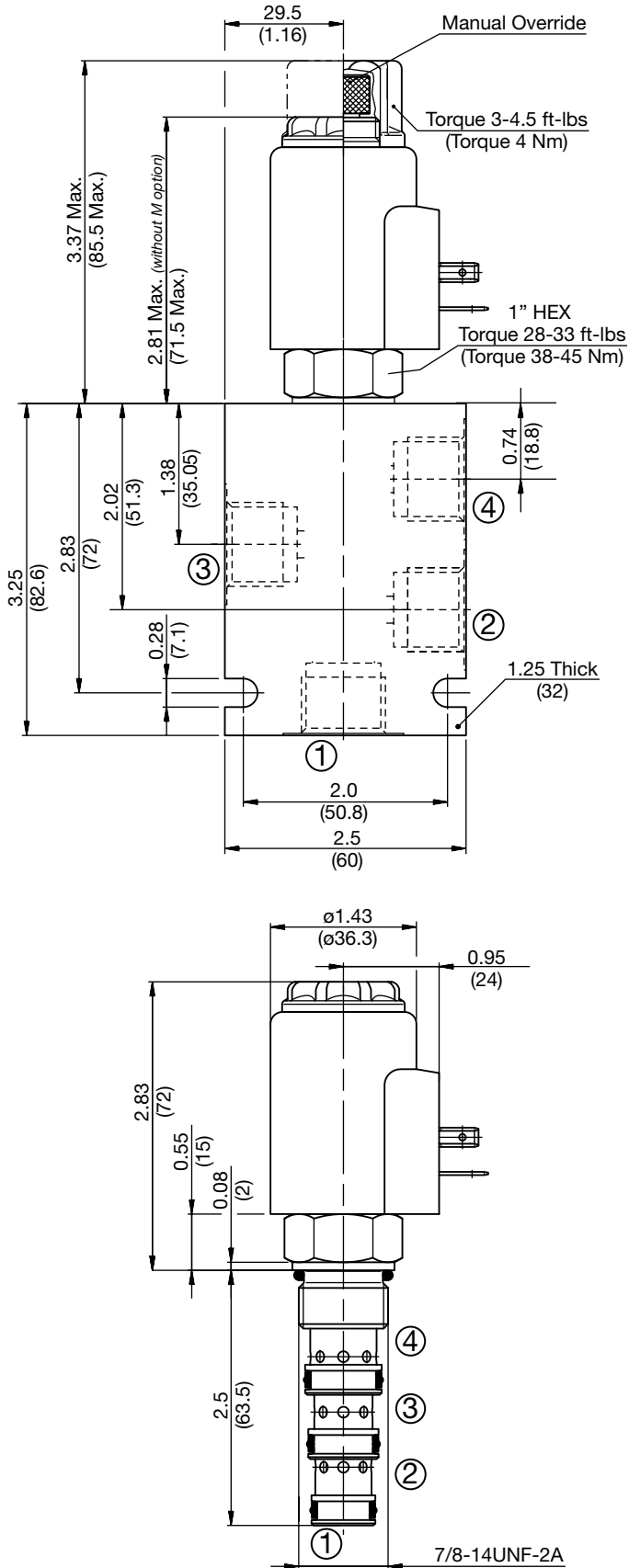

All measurements in inches (mm).
Subject to technical modifications

Model Code

WK10K-01 M-C-N-24 DN

Valve Model

Override Option

- blank = No manual override
- M = Manual override, screw type

Body & Ports

- C = Cartridge only
- AS8 = SAE-8 Ports, aluminum body
- SS8 = SAE-8 Ports, steel body

Seals

- N = Buna-N
- V = Viton®

Coil Voltage

- 0 = No coil, cartridge only
- DC 12 = 12 VDC
- 24 = 24 VDC
- 36 = 36 VDC
- 110 = 110 VDC (only available with connector DG)
- AC 24 = 24 VAC
- 115 = 115 VAC (AC coils internally full wave rectified)
- 230 = 230 VAC

Coil Connector

- DC DG = EN 175301-803-A
- DS = Dual spade (SAEJ858a)*
- DL = Leadwires (2) - 18" long (46 cm)*
- DW = WeatherPak™ on leadwires - 9.5" long (24 cm)*
- DN = Deutsch™ DT04-2P, molded, axial (IP69K Rated)*
- DT = Amp Junior Timer™, molded, radial mount*
- AC AG = EN 175301-803-A

Coil Model 50-1836

For other coil connector types consult factory

*Coils with internal diode are available, consult factory.

Standard Line Bodies*

Code	Part No	Material	Pressure Rating	Weight
FH104-AS8	03038110	Aluminum, anodized	3500 psi (245 bar)	0.72 lbs (0.33 kg)
FH104-SS8	03037868	Steel, zinc plated	6000 psi (420 bar)	2.12 lbs (0.96 kg)

*Please refer to Line Bodies & Cavities section for details

SOLENOID VALVES

WK10N-01

Spool Type, Direct Acting

Up to 8.4 gpm (32 l/min) • 5000 psi (350 bar)

Hydraulic Symbol

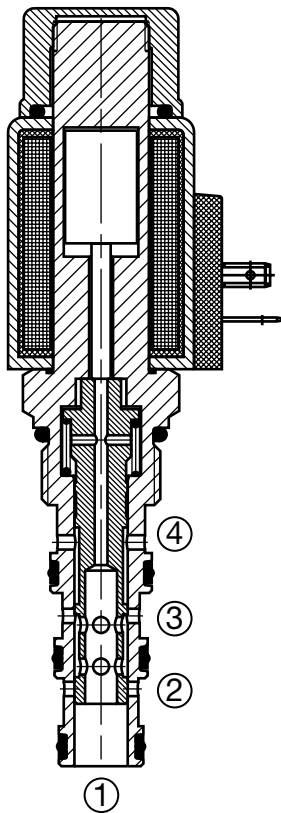
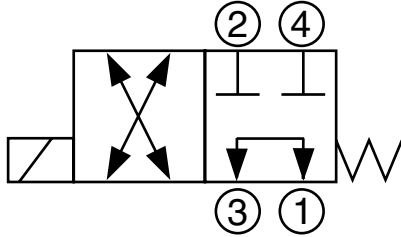

Description

A screw-in cartridge, solenoid operated, 4-way, 2 position, direct acting, spool type valve.

Operation

When de-energized the WK10N allows flow from port 1 to port 3 bi-directionally, ports 2 and 4 are blocked. When energized the spool shifts and allows flow from port 1 to port 2 bi-directionally and from port 3 to port 4 bi-directionally.

Operation of Manual Override Option: To override, push and hold the override button. The override is not detented. The manual override option is intended for emergency use, not for continuous duty operation.

Features

- Push type manual override button, protected by rubber cap

Specifications

Operating Pressure	5000 psi (350 bar)
Nominal Flow	8.4 gpm at 5000 psi (32 l/min at 350 bar)
Internal Leakage	7.3 cu in/min. at 3600 psi and 158 SUS (120 cc/min at 250 bar and 34 cSt)
Fluid Operating Temp. Range	-4° to 248°F (-20° to 120°C) <i>(Consult factory for usage at temp. outside range.)</i>
Ambient Temperature Range	-4° to 140°F (-20° to 60°C)
Coil Duty Rating	Continuous from 85% to 115% of nominal voltage
Current Draw @ 68°F (20°C)	2.22 A at 12VDC; 1.13 A at 24VDC
Min. Pull-in Voltage @ 68°F (20°C)	85% of nominal @ 5000 psi (350 bar)
Fluid Compatibility	Mineral-based or synthetics with lubricating properties
Viscosity	50 to 2000 SUS (7.4 to 420 cSt)
Filtration	21/19/16 or cleaner (per ISO 4406). Use with filter rated $\beta_{10} \geq 200$.
Installation	No orientation restrictions
Cavity	FC10-4 (see <i>Line Bodies & Cavities</i> section)
Cavity Tools	Rougher: 02580248 Finisher: 02580249
Cartridge Weight	0.55 Lbs. (0.25 kg)
Coil Weight	0.51 Lbs. (0.23 kg)
Cartridge Material	Steel with hardened work surfaces. Zinc-plated exposed surfaces. Buna N or Viton® o-rings. PTFE back-up rings.
Coil Material	Class N high temperature magnet wire, steel shell, polyamid encapsulation.
Seal Kits	Buna-N P/N: 03051912 Viton® P/N: 03071275

Performance

Measured at 158 SUS (34 cSt)
 $T_{oil} = 115^{\circ}F (46^{\circ}C)$

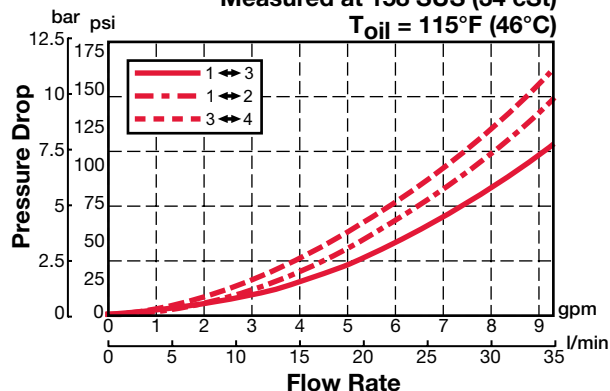

Dimensions

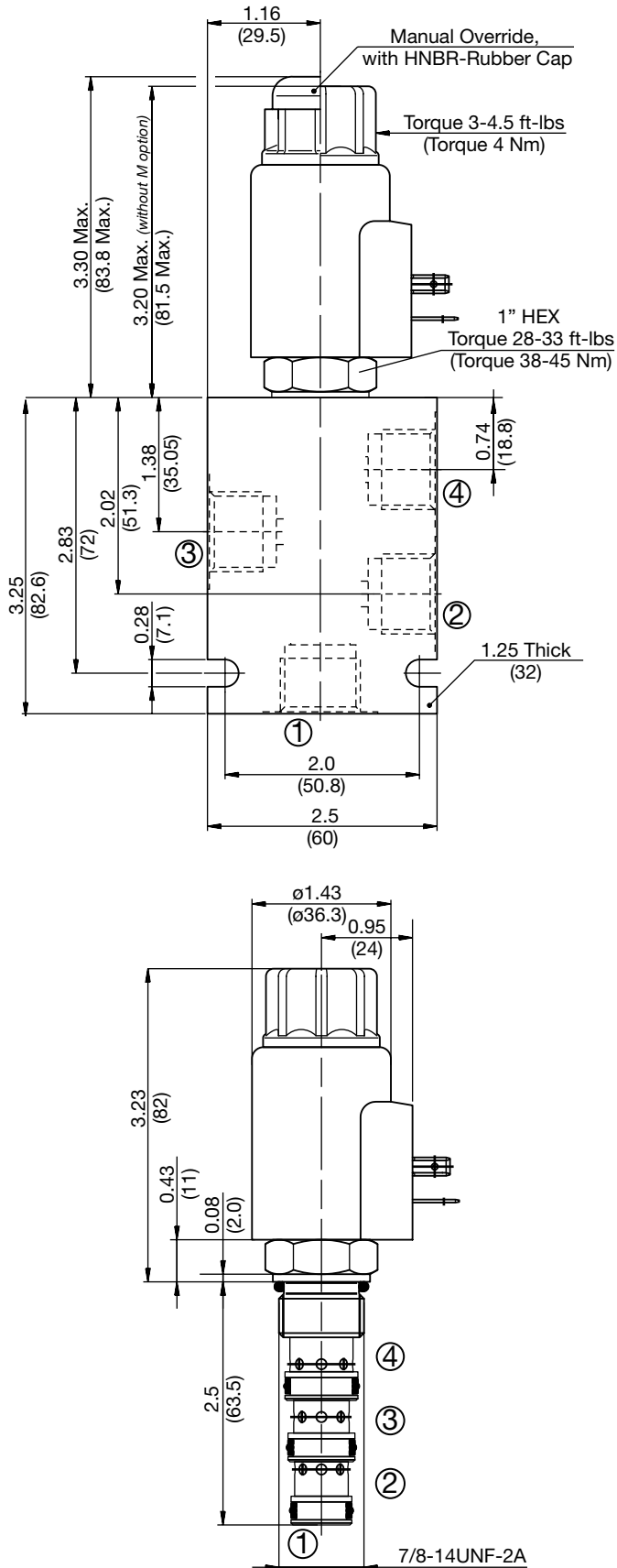

Model Code

WK10N-01 M-C-N-24 DN

- Valve Model** _____
- Override Option** _____
 blank = No manual override
 M = Manual override, push type
- Body & Ports** _____
 C = Cartridge only
 AS8 = SAE-8 Ports, aluminum body
 SS8 = SAE-8 Ports, steel body
- Seals** _____
 N = Buna-N
 V = Viton®
- Coil Voltage** _____
 0 = No coil, cartridge only
- DC** _____
 12 = 12 VDC
 24 = 24 VDC
 36 = 36 VDC
 110 = 110 VDC (only available with connector DG)
- AC** _____
 24 = 24 VAC
 115 = 115 VAC (AC coils internally full wave rectified)
 230 = 230 VAC
- Coil Connector** _____
 DC DG = EN 175301-803-A
 DS = Dual spade (SAEJ858a)*
 DL = Leadwires (2) - 18" long (46 cm)*
 DW = WeatherPak™ on leadwires - 9.5" long (24 cm)*
 DN = Deutsch™ DT04-2P, molded, axial (IP69K Rated)*
 DT = Amp Junior Timer™, molded, radial mount*
- AC AG = EN 175301-803-A

Coil Model 50-1836

For other coil connector types consult factory

*Coils with internal diode are available, consult factory.

All measurements in inches (mm).
Subject to technical modifications

Standard Line Bodies*

Code	Part No	Material	Pressure Rating	Weight
FH104-AS8	03038110	Aluminum, anodized	3500 psi (245 bar)	0.72 lbs (0.33 kg)
FH104-SS8	03037868	Steel, Zinc plated	6000 psi (420 bar)	2.12 lbs (0.96 kg)

*Please refer to Line Bodies & Cavities section for details

SOLENOID VALVES

WK08P-01

Spool Type, Direct Acting

Up to 4 gpm (15 l/min) • 5000 psi (350 bar)

Hydraulic Symbol

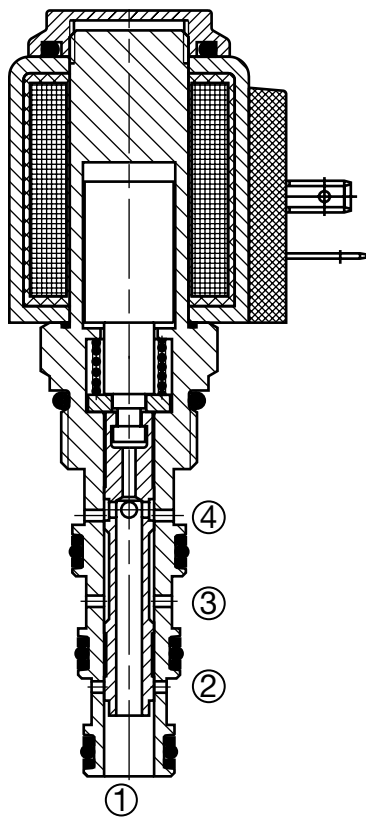
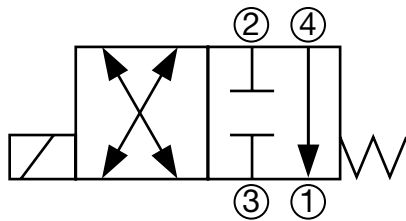

Description

A screw-in cartridge, solenoid operated, 4-way, 2 position, direct acting, spool type valve.

Operation

When de-energized the WK08P blocks flow at ports 2 and 3, flow is allowed from port 1 to port 4 bi-directionally. When energized the spool shifts and allows flow from port 1 to port 2 bi-directionally and from port 3 to port 4 bi-directionally.

Operation of Manual Override Option: To override, remove the coil nut, turn the override knurled knob counterclockwise until it stops. The override will remain activated until the knob is turned clockwise to original position. The manual override option is intended for emergency use, not for continuous duty operation.

Features

- Screw type manual override

Specifications

Operating Pressure	5000 psi (350 bar)
Nominal Flow	4 gpm at 3600 psi (15 l/min at 250 bar) 2 gpm at 5000 psi (7.6 l/min at 350 bar)
Internal Leakage	5.5 cu in/min. at 3600 psi and 158 SUS (90 cc/min at 250 bar and 34 cSt)
Fluid Operating Temp. Range	-4° to 248°F (-20° to 120°C) (Consult factory for usage at temp. outside range.)
Ambient Temperature Range	-4° to 140°F (-20° to 60°C)
Coil Duty Rating	Continuous from 85% to 115% of nominal voltage
Current Draw @ 68°F (20°C)	1.5 A at 12VDC; 0.8 A at 24VDC
Min. Pull-in Voltage @ 68°F (20°C)	85% of nominal @ 5000 psi (350 bar)
Fluid Compatibility	Mineral-based or synthetics with lubricating properties
Viscosity	50 to 2000 SUS (7.4 to 420 cSt)
Filtration	21/19/16 or cleaner (per ISO 4406). Use with filter rated $\beta_{10} \geq 200$.
Installation	No orientation restrictions
Cavity	FC08-4 (see <i>Line Bodies & Cavities</i> section)
Cavity Tools	Rougher: 02580088 Finisher: 02580089
Cartridge Weight	0.42 Lbs. (0.19 kg)
Coil Weight	0.42 Lbs. (0.19 kg)
Cartridge Material	Steel with hardened work surfaces. Zinc-plated exposed surfaces. Buna N or Viton® o-rings. PTFE back-up rings.
Coil Material	Class N high temperature magnet wire, steel shell, polyamid encapsulation.
Seal Kits	Buna-N P/N: 03071272 Viton® P/N: 03071273

Performance

Measured at 158 SUS (34 cSt)
 $T_{oil} = 115^{\circ}\text{F} (46^{\circ}\text{C})$

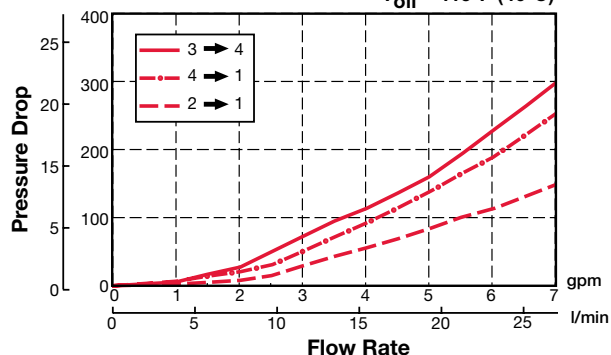

Dimensions

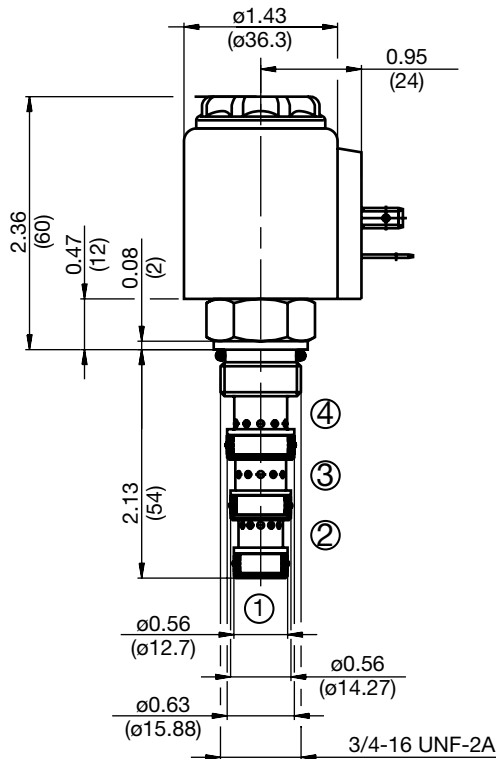
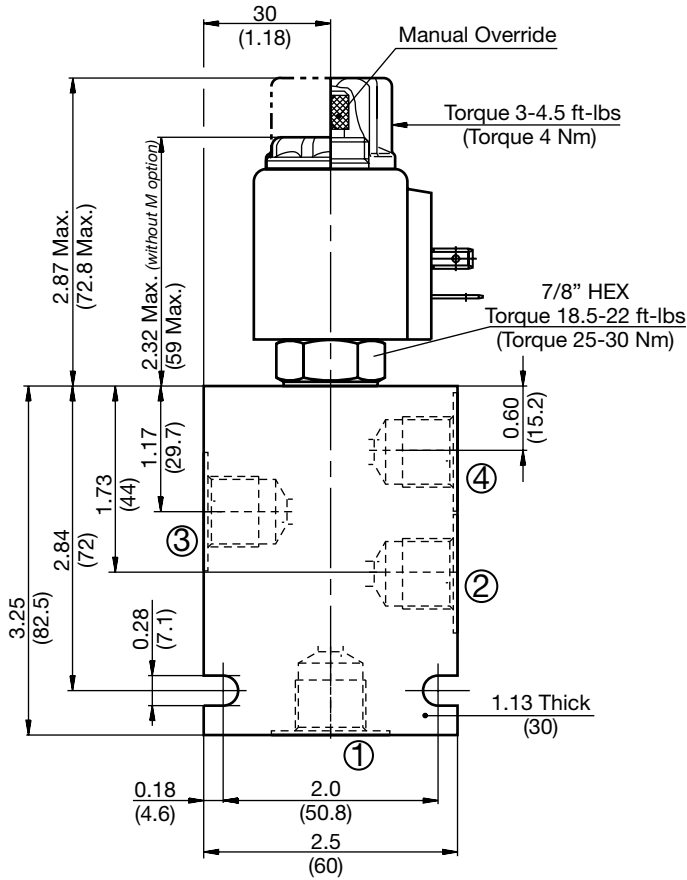

All measurements in inches (mm).
Subject to technical modifications

Model Code

WK08P-01 M-C-N-24 DN

- Valve Model** _____
- Override Option** _____
 blank = No manual override
 M = Manual override, screw type
- Body & Ports** _____
 C = Cartridge only
 AS6 = SAE-6 Ports, aluminum body
 SS6 = SAE-6 Ports, steel body
- Seals** _____
 N = Buna-N
 V = Viton®
- Coil Voltage** _____
 0 = No coil, cartridge only
 DC 12 = 12 VDC
 24 = 24 VDC
 36 = 36 VDC
 110 = 110 VDC (only available with connector DG)
 AC 24 = 24 VAC
 115 = 115 VAC (AC coils internally full wave rectified)
 230 = 230 VAC
- Coil Connector** _____
 DC DG = EN 175301-803-A
 DS = Dual spade (SAEJ858a)*
 DL = Leadwires (2) - 18" long (46 cm)*
 DW = WeatherPak™ on leadwires - 9.5" long (24 cm)*
 DN = Deutsch™ DT04-2P, molded, axial (IP69K Rated)*
 DT = Amp Junior Timer™, molded, radial mount*
- AC AG = EN 175301-803-A

Coil Model 40-1836

For other coil connector types consult factory

*Coils with internal diode are available, consult factory.

Standard Line Bodies*

Code	Part No	Material	Pressure Rating	Weight
FH084-AS6	03011404	Aluminum, anodized	3500 psi (245 bar)	0.72 lbs (0.33 kg)
FH084-SS6	00563381	Steel, zinc plated	6000 psi (420 bar)	2.12 lbs (0.96 kg)

*Please refer to Line Bodies & Cavities section for details

SOLENOID VALVES

WK10P-01

Spool Type, Direct Acting

Up to 8.4 gpm (32 l/min) • 5000 psi (350 bar)

Hydraulic Symbol

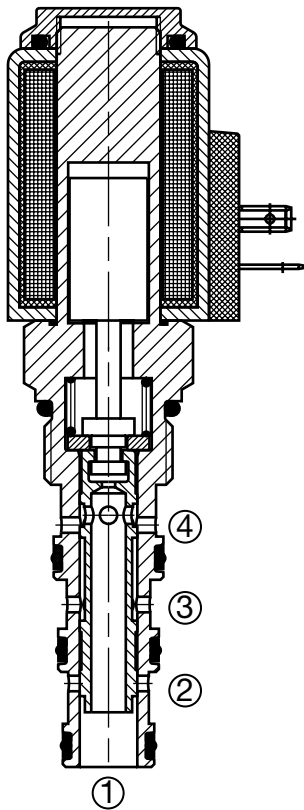
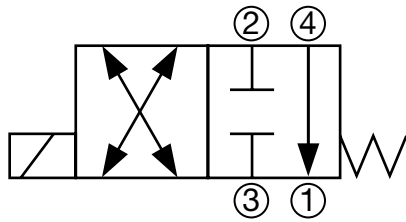

Description

A screw-in cartridge, solenoid operated, 4-way, 2 position, direct acting, spool type valve.

Operation

When de-energized the WK10P blocks flow at ports 2 and 3, flow is allowed from port 1 to port 4 bi-directionally. When energized the spool shifts and allows flow from port 1 to port 2 bi-directionally and from port 3 to port 4 bi-directionally.

Operation of Manual Override Option: To override, remove the coil nut, turn the override knurled knob counterclockwise until it stops. The override will remain activated until the knob is turned clockwise to original position. The manual override option is intended for emergency use, not for continuous duty operation.

Features

- Screw type manual override

Specifications

Operating Pressure	5000 psi (350 bar)
Nominal Flow	8.4 gpm at 5000 psi (32 l/min at 350 bar)
Internal Leakage	7.3 cu in/min. at 3600 psi and 158 SUS (120 cc/min at 250 bar and 34 cSt)
Fluid Operating Temp. Range	-4° to 248°F (-20° to 120°C) (Consult factory for usage at temp. outside range.)
Ambient Temperature Range	-4° to 140°F (-20° to 60°C)
Coil Duty Rating	Continuous from 85% to 115% of nominal voltage
Current Draw @ 68°F (20°C)	2.22 A at 12VDC; 1.13 A at 24VDC
Min. Pull-in Voltage @ 68°F (20°C)	85% of nominal @ 5000 psi (350 bar)
Fluid Compatibility	Mineral-based or synthetics with lubricating properties
Viscosity	50 to 2000 SUS (7.4 to 420 cSt)
Filtration	21/19/16 or cleaner (per ISO 4406). Use with filter rated $\beta_{10} \geq 200$.
Installation	No orientation restrictions
Cavity	FC10-4 (see Line Bodies & Cavities section)
Cavity Tools	Rougher: 02580248 Finisher: 02580249
Cartridge Weight	0.55 Lbs. (0.25 kg)
Coil Weight	0.51 Lbs. (0.23 kg)
Cartridge Material	Steel with hardened work surfaces. Zinc-plated exposed surfaces. Buna N or Viton® o-rings. PTFE back-up rings.
Coil Material	Class N high temperature magnet wire, steel shell, polyamid encapsulation.
Seal Kits	Buna-N P/N: 03051912 Viton® P/N: 03071275

Performance

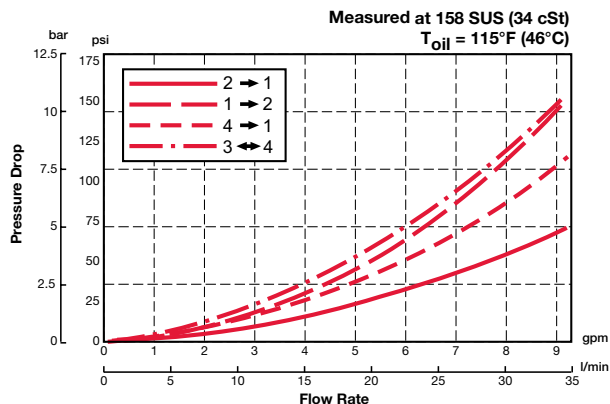

Dimensions

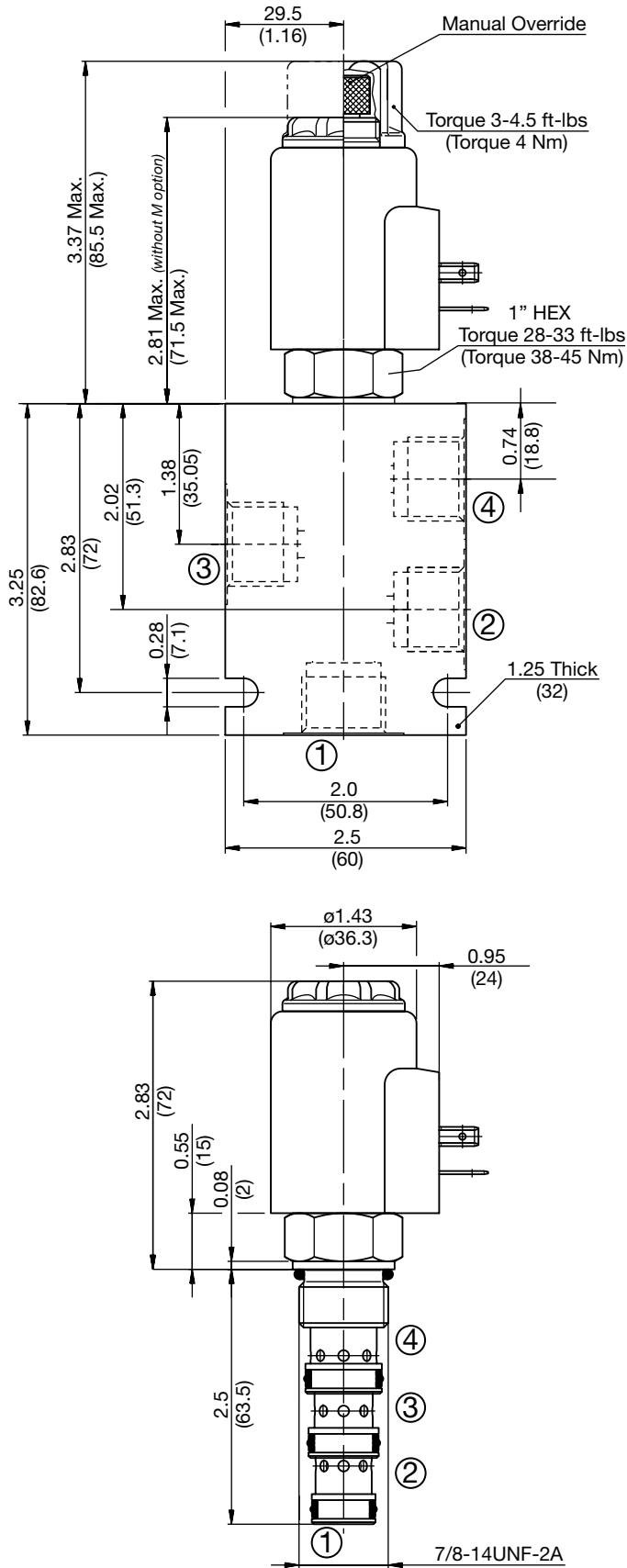

Model Code

WK10P-01 M-C-N-24 DN

Valve Model

Override Option

- blank = No manual override
- M = Manual override, screw type

Body & Ports

- C = Cartridge only
- AS8 = SAE-8 Ports, aluminum body
- SS8 = SAE-8 Ports, steel body

Seals

- N = Buna-N
- V = Viton®

Coil Voltage

- 0 = No coil, cartridge only
- DC 12 = 12 VDC
- 24 = 24 VDC
- 36 = 36 VDC
- 110 = 110 VDC (only available with connector DG)
- AC 24 = 24 VAC
- 115 = 115 VAC (AC coils internally full wave rectified)
- 230 = 230 VAC

Coil Connector

- DC DG = EN 175301-803-A
- DS = Dual spade (SAEJ858a)*
- DL = Leadwires (2) - 18" long (46 cm)*
- DW = WeatherPak™ on leadwires - 9.5" long (24 cm)*
- DN = Deutsch™ DT04-2P, molded, axial (IP69K Rated)*
- DT = Amp Junior Timer™, molded, radial mount*
- AC AG = EN 175301-803-A

Coil Model 50-1836

For other coil connector types consult factory

*Coils with internal diode are available, consult factory.

All measurements in inches (mm).
Subject to technical modifications

PN#02087369 / 10.19 / CHD1110-1389

Standard Line Bodies*

Code	Part No	Material	Pressure Rating	Weight
FH104-AS8	03038110	Aluminum, anodized	3500 psi (245 bar)	0.72 lbs (0.33 kg)
FH104-SS8	03037868	Steel, zinc plated	6000 psi (420 bar)	2.12 lbs (0.96 kg)

*Please refer to Line Bodies & Cavities section for details

SOLENOID VALVES

WK08R-01

Spool Type, Direct Acting

Up to 5 gpm (19 l/min) • 5000 psi (350 bar)

Hydraulic Symbol

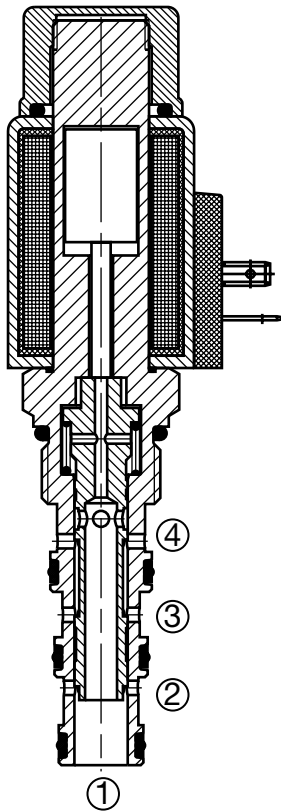
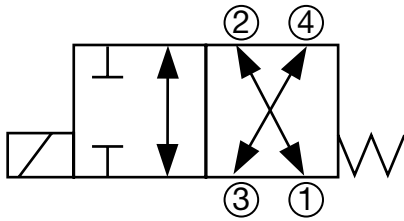

Description

A screw-in cartridge, solenoid operated, 4-way, 2 position, direct acting, spool type valve.

Operation

When de-energized the WK08R allows flow from port 2 to port 1 bi-directionally and port 3 to port 4 bi-directionally. When energized the spool shifts and allows bi-directional flow from port 1 to port 4, ports 2 and 3 are blocked.

Operation of Manual Override Option: To override, push and hold the override button. The override is not detented. The manual override option is intended for emergency use, not for continuous duty operation.

Features

- Push type manual override button, protected by rubber cap

Specifications

Operating Pressure	5000 psi (350 bar)
Nominal Flow	5 gpm at 3600 psi (19 l/min at 250 bar)
Internal Leakage	5.5 cu in/min. at 3600 psi and 158 SUS (90 cc/min at 250 bar and 34 cSt)
Fluid Operating Temp. Range	-4° to 248°F (-20° to 120°C) (Consult factory for usage at temp. outside range.)
Ambient Temperature Range	-4° to 140°F (-20° to 60°C)
Coil Duty Rating	Continuous from 85% to 115% of nominal voltage
Current Draw @ 68°F (20°C)	1.5 A at 12VDC; 0.8 A at 24VDC
Min. Pull-in Voltage @ 68°F (20°C)	85% of nominal @ 5000 psi (350 bar)
Fluid Compatibility	Mineral-based or synthetics with lubricating properties
Viscosity	50 to 2000 SUS (7.4 to 420 cSt)
Filtration	21/19/16 or cleaner (per ISO 4406). Use with filter rated $\beta_{10} \geq 200$.
Installation	No orientation restrictions
Cavity	FC08-4 (see <i>Line Bodies & Cavities</i> section)
Cavity Tools	Rougher: 02580088 Finisher: 02580089
Cartridge Weight	0.42 Lbs. (0.19 kg)
Coil Weight	0.42 Lbs. (0.19 kg)
Cartridge Material	Steel with hardened work surfaces. Zinc-plated exposed surfaces. Buna N or Viton® o-rings. PTFE back-up rings.
Coil Material	Class N high temperature magnet wire, steel shell, polyamid encapsulation.
Seal Kits	Buna-N P/N: 03071272 Viton® P/N: 03071273

Performance

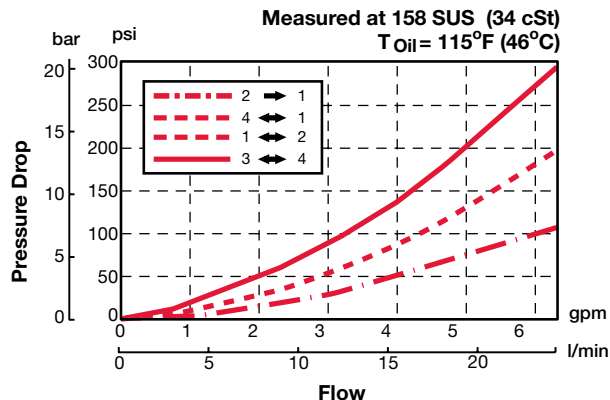

Dimensions

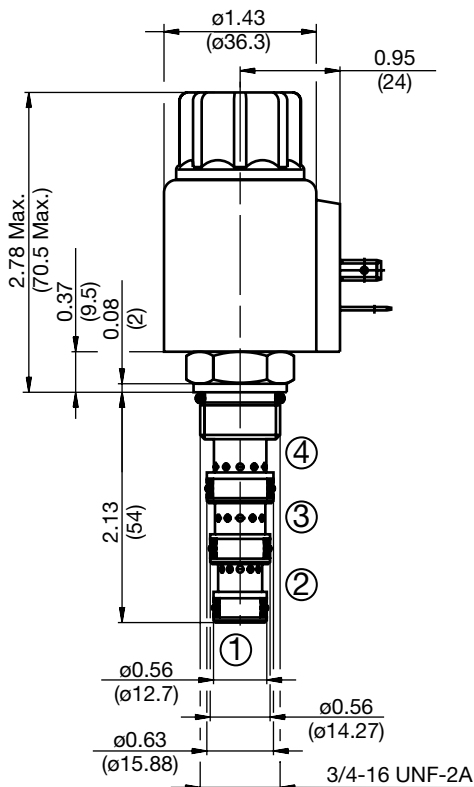
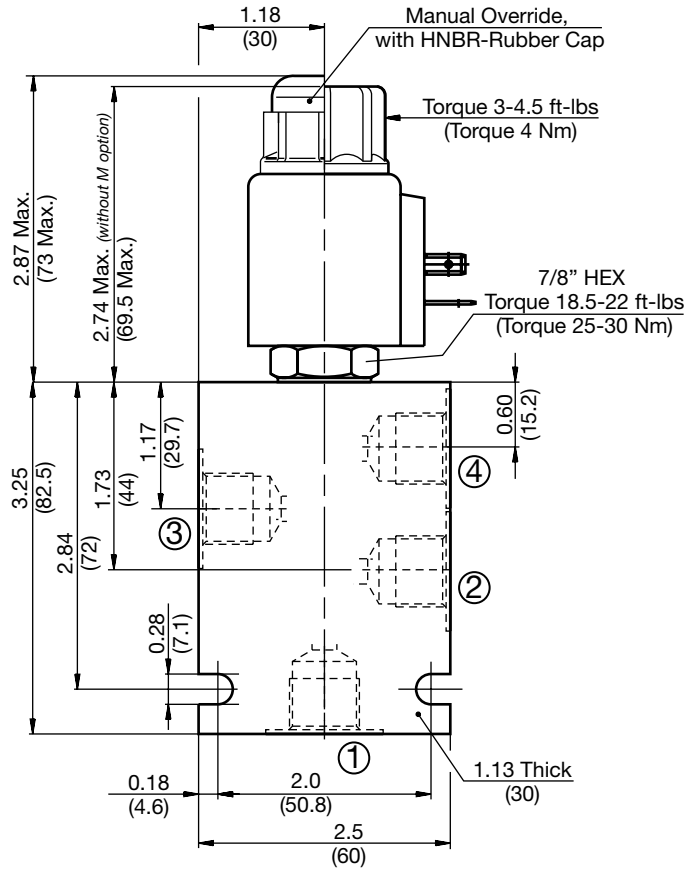

Model Code

WK08R-01 M-C-N-24 DN

Valve Model

Override Option

- blank = No manual override
- M = Manual override, push type

Body & Ports

- C = Cartridge only
- AS6 = SAE-6 Ports, aluminum body
- SS6 = SAE-6 Ports, steel body

Seals

- N = Buna-N
- V = Viton®

Coil Voltage

- 0 = No coil, cartridge only

DC

- 12 = 12 VDC
- 24 = 24 VDC
- 36 = 36 VDC
- 110 = 110 VDC (only available with connector DG)

AC

- 24 = 24 VAC
- 115 = 115 VAC (AC coils internally full wave rectified)
- 230 = 230 VAC

Coil Connector

- DC DG = EN 175301-803-A
- DS = Dual spade (SAEJ858a)*
- DL = Leadwires (2) - 18" long (46 cm)*
- DW = WeatherPak™ on leadwires - 9.5" long (24 cm)*
- DN = Deutsch™ DT04-2P, molded, axial (IP69K Rated)*
- DT = Amp Junior Timer™, molded, radial mount*

AC AG = EN 175301-803-A

Coil Model 40-1836

For other coil connector types consult factory

*Coils with internal diode are available, consult factory.

Operating Limits

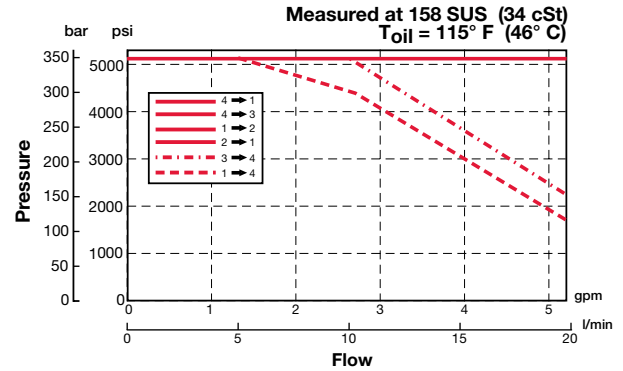

Standard Line Bodies*

Code	Part No	Material	Pressure Rating	Weight
FH084-AS6	03011404	Aluminum, anodized	3500 psi (245 bar)	0.72 lbs (0.33 kg)
FH084-SS6	00563381	Steel, zinc plated	6000 psi (420 bar)	2.12 lbs (0.96 kg)

*Please refer to Line Bodies & Cavities section for details

All measurements in inches (mm).
Subject to technical modifications

SOLENOID VALVES

WK10R-01

Spool Type, Direct Acting

Up to 8.4 gpm (32 l/min) • 5000 psi (350 bar)

Hydraulic Symbol

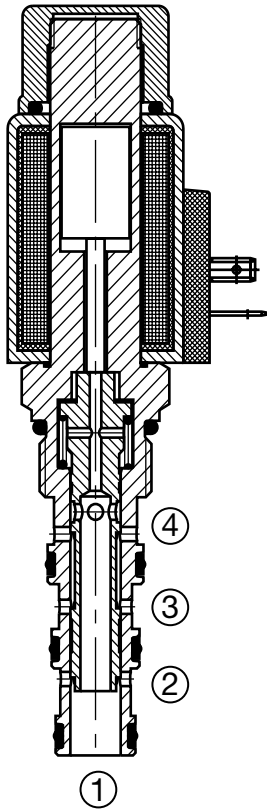
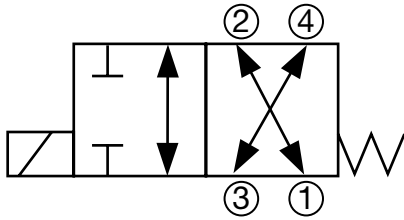

Description

A screw-in cartridge, solenoid operated, 4-way, 2 position, direct acting, spool type valve.

Operation

When de-energized the WK10R allows flow from port 3 to port 4 bi-directionally and port 2 to port 1 bi-directionally. When energized the spool shifts and blocks flow at ports 2 and 3, allowing the flow from port 1 to port 4 bi-directionally.

Operation of Manual Override Option: To override, push and hold the override button. The override is not detented. The manual override option is intended for emergency use, not for continuous duty operation

Features

- Push type manual override button, protected by rubber cap

Specifications

Operating Pressure	5000 psi (350 bar)
Nominal Flow	8.4 gpm at 5000 psi (32 l/min at 350 bar)
Internal Leakage	6 cu in/min. at 3600 psi and 158 SUS (100 cc/min at 250 bar and 34 cSt)
Fluid Operating Temp. Range	-4° to 248°F (-20° to 120°C) <i>(Consult factory for usage at temp. outside range.)</i>
Ambient Temperature Range	-4° to 140°F (-20° to 60°C)
Coil Duty Rating	Continuous from 85% to 115% of nominal voltage
Current Draw @ 68°F (20°C)	2.22 A at 12VDC; 1.13 A at 24VDC
Min. Pull-in Voltage @ 68°F (20°C)	85% of nominal @ 5000 psi (350 bar)
Fluid Compatibility	Mineral-based or synthetics with lubricating properties
Viscosity	50 to 2000 SUS (7.4 to 420 cSt)
Filtration	21/19/16 or cleaner (per ISO 4406). Use with filter rated $\beta_{10} \geq 200$.
Installation	No orientation restrictions
Cavity	FC10-4 (see <i>Line Bodies & Cavities</i> section)
Cavity Tools	Rougher: 02580248 Finisher: 02580249
Cartridge Weight	0.55 Lbs. (0.25 kg)
Coil Weight	0.51 Lbs. (0.23 kg)
Cartridge Material	Steel with hardened work surfaces. Zinc-plated exposed surfaces. Buna N or Viton® o-rings. PTFE back-up rings.
Coil Material	Class N high temperature magnet wire, steel shell, polyamid encapsulation.
Seal Kits	Buna-N P/N: 03051912 Viton® P/N: 03071275

Performance

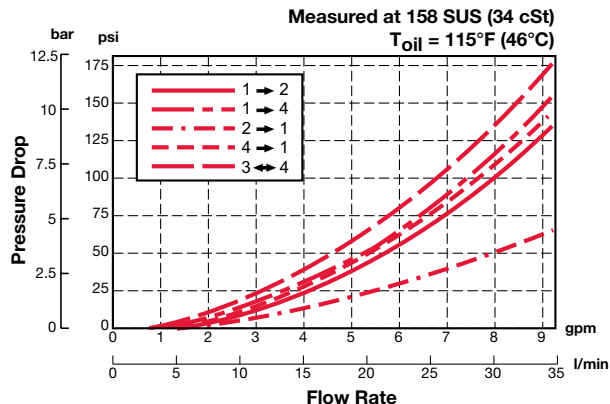

Dimensions

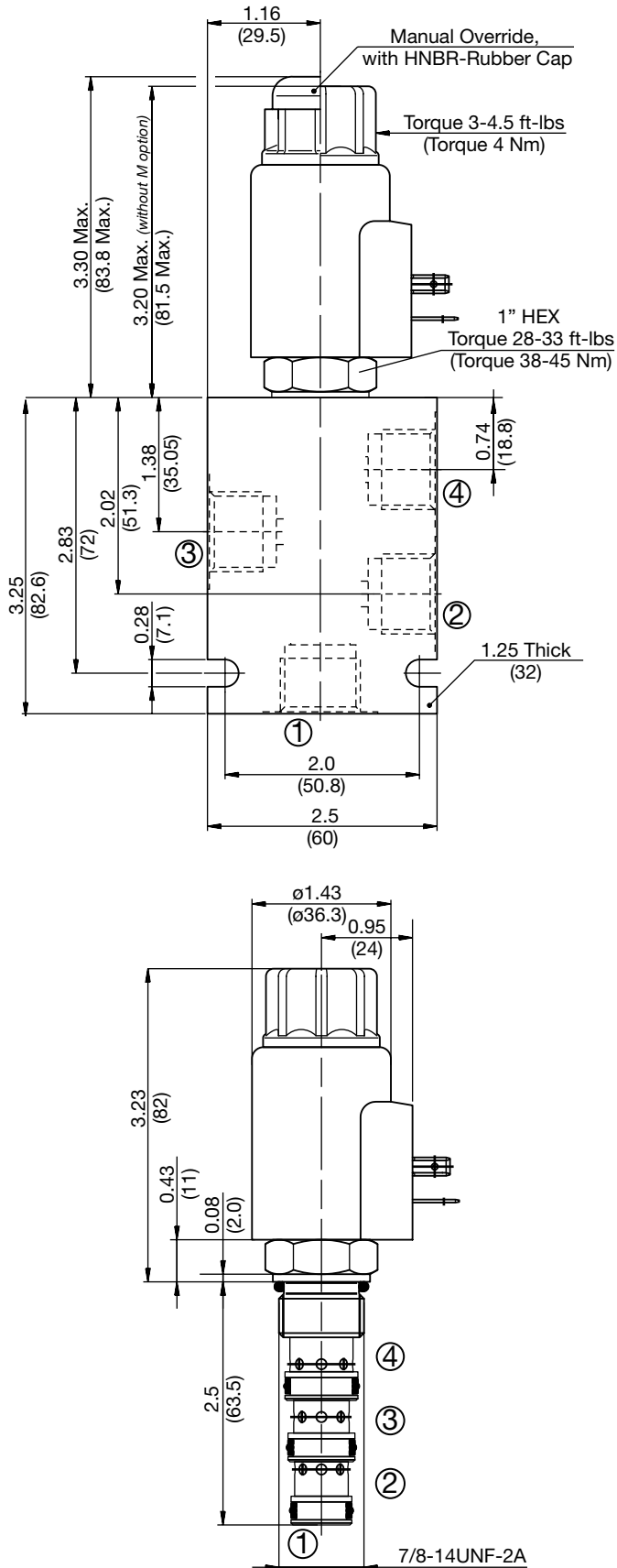

Model Code

WK10R-01 M-C-N-24 DN

- Valve Model** _____
- Override Option** _____
blank = No manual override
M = Manual override, push type
- Body & Ports** _____
C = Cartridge only
AS8 = SAE-8 Ports, aluminum body
SS8 = SAE-8 Ports, steel body
- Seals** _____
N = Buna-N
V = Viton®
- Coil Voltage** _____
0 = No coil, cartridge only
- DC** _____
12 = 12 VDC
24 = 24 VDC
36 = 36 VDC
110 = 110 VDC (only available with connector DG)
- AC** _____
24 = 24 VAC
115 = 115 VAC (AC coils internally full wave rectified)
230 = 230 VAC
- Coil Connector** _____
DC DG = EN 175301-803-A
DS = Dual spade (SAEJ858a)*
DL = Leadwires (2) - 18" long (46 cm)*
DW = WeatherPak™ on leadwires - 9.5" long (24 cm)*
DN = Deutsch™ DT04-2P, molded, axial (IP69K Rated)*
DT = Amp Junior Timer™, molded, radial mount*
- AC AG = EN 175301-803-A

Coil Model 50-1836

For other coil connector types consult factory

*Coils with internal diode are available, consult factory.

All measurements in inches (mm).
Subject to technical modifications

PN#02087369 / 10.19 / CHD1110-1389

Standard Line Bodies*

Code	Part No	Material	Pressure Rating	Weight
FH104-AS8	03038110	Aluminum, anodized	3500 psi (245 bar)	0.72 lbs (0.33 kg)
FH104-SS8	03037868	Steel, zinc plated	6000 psi (420 bar)	2.12 lbs (0.96 kg)

*Please refer to Line Bodies & Cavities section for details

SOLENOID VALVES

WK08X-01

Spool Type, Direct Acting

Up to 4.5 gpm (17 l/min) • 5000 psi (350 bar)

Hydraulic Symbol

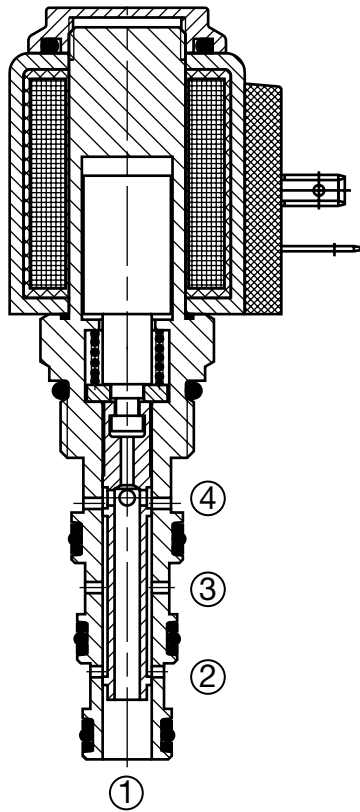
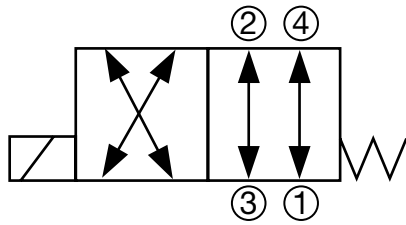

Description

A screw-in cartridge, solenoid operated, 4-way, 2 position, direct acting, spool type valve.

Operation

When de-energized the WK08X allows flow from port 2 to port 3 bi-directionally and port 1 to port 4 bi-directionally. When energized the spool shifts and allows flow from port 3 to port 4 bi-directionally and from port 2 to port 1 bi-directionally.

Operation of Manual Override Option: To override, remove the coil nut, turn the override knurled knob counterclockwise until it stops. The override will remain activated until the knob is turned clockwise to original position. The manual override option is intended for emergency use, not for continuous duty operation.

Features

- Screw type manual override

Specifications

Operating Pressure	5000 psi (350 bar)
Nominal Flow	4.5 gpm at 3600 psi (17 l/min at 250 bar)
Internal Leakage	5.5 cu in/min. at 3600 psi and 158 SUS (90 cc/min at 250 bar and 34 cSt)
Fluid Operating Temp. Range	-4° to 248°F (-20° to 120°C) (Consult factory for usage at temp. outside range.)
Ambient Temperature Range	-4° to 140°F (-20° to 60°C)
Coil Duty Rating	Continuous from 85% to 115% of nominal voltage
Current Draw @ 68°F (20°C)	1.5 A at 12VDC; 0.8 A at 24VDC
Min. Pull-in Voltage @ 68°F (20°C)	85% of nominal @ 5000 psi (350 bar)
Fluid Compatibility	Mineral-based or synthetics with lubricating properties
Viscosity	50 to 2000 SUS (7.4 to 420 cSt)
Filtration	21/19/16 or cleaner (per ISO 4406). Use with filter rated $\beta_{10} \geq 200$.
Installation	No orientation restrictions
Cavity	FC08-4 (see <i>Line Bodies & Cavities</i> section)
Cavity Tools	Rougher: 02580088 Finisher: 02580089
Cartridge Weight	0.42 Lbs. (0.19 kg)
Coil Weight	0.42 Lbs. (0.19 kg)
Cartridge Material	Steel with hardened work surfaces. Zinc-plated exposed surfaces. Buna N or Viton® o-rings. PTFE back-up rings.
Coil Material	Class N high temperature magnet wire, steel shell, polyamid encapsulation.
Seal Kits	Buna-N P/N: 03071272 Viton® P/N: 03071273

Performance

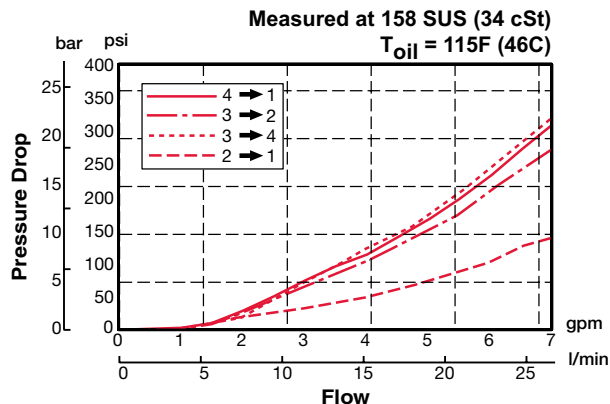

Dimensions

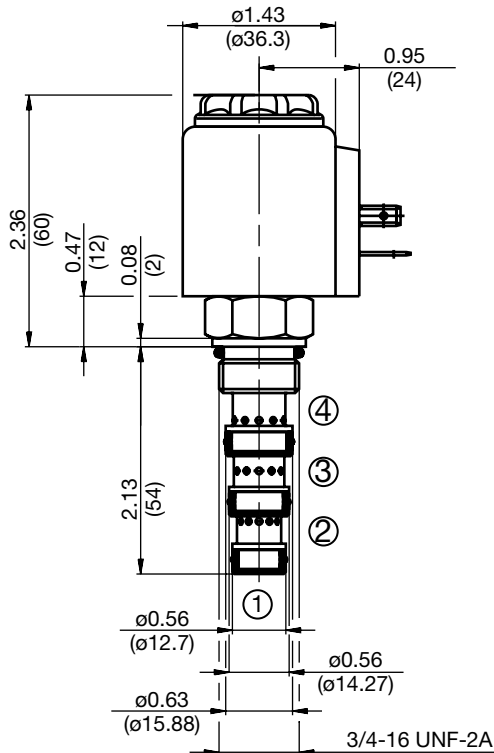
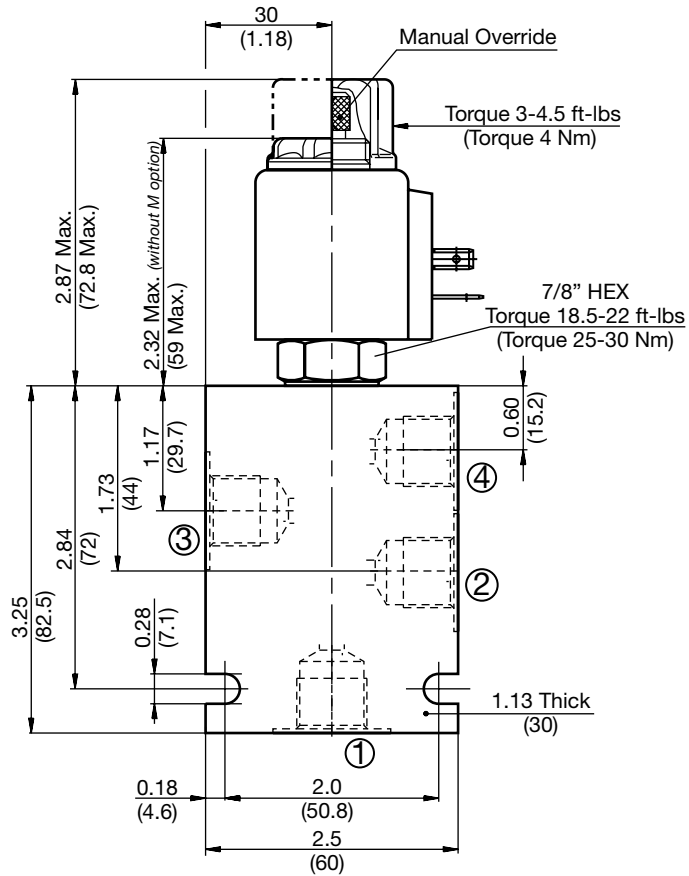

All measurements in inches (mm).
Subject to technical modifications

Model Code

WK08X-01 M-C-N-24 DN

Valve Model

Override Option

blank = No manual override
M = Manual override, screw type

Body & Ports

C = Cartridge only
AS6 = SAE-6 Ports, aluminum body
SS6 = SAE-6 Ports, steel body

Seals

N = Buna-N
V = Viton®

Coil Voltage

0 = No coil, cartridge only
DC 12 = 12 VDC
24 = 24 VDC
36 = 36 VDC
110 = 110 VDC (only available with connector DG)
AC 24 = 24 VAC
115 = 115 VAC (AC coils internally full wave rectified)
230 = 230 VAC

Coil Connector

DC DG = EN 175301-803-A
DS = Dual spade (SAEJ858a)*
DL = Leadwires (2) - 18" long (46 cm)*
DW = WeatherPak™ on leadwires - 9.5" long (24 cm)*
DN = Deutsch™ DT04-2P, molded, axial (IP69K Rated)*
DT = Amp Junior Timer™, molded, radial mount*
AC AG = EN 175301-803-A

Coil Model 40-1836

For other coil connector types consult factory

*Coils with internal diode are available, consult factory.

Standard Line Bodies*

Code	Part No	Material	Pressure Rating	Weight
FH084-AS6	03011404	Aluminum, anodized	3500 psi (245 bar)	0.72 lbs (0.33 kg)
FH084-SS6	00563381	Steel, zinc plated	6000 psi (420 bar)	2.12 lbs (0.96 kg)

*Please refer to Line Bodies & Cavities section for details

SOLENOID VALVES

WK10X-01

Spool Type, Direct Acting

Up to 8.4 gpm (32 l/min) • 5000 psi (350 bar)

Hydraulic Symbol

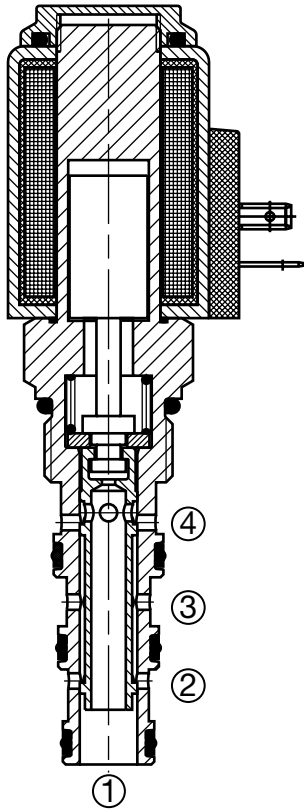
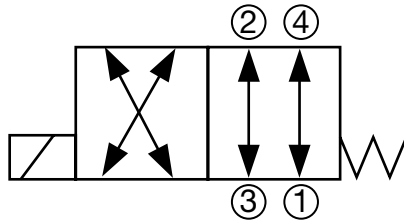

Description

A screw-in cartridge, solenoid operated, 4-way, 2 position, direct acting, spool type valve.

Operation

When de-energized the WK10X allows flow from port 2 to port 3 bi-directionally and port 1 to port 4 bi-directionally. When energized the spool shifts and allows flow from port 3 to port 4 bi-directionally and from port 2 to port 1 bi-directionally.

Operation of Manual Override Option: To override, remove the coil nut, turn the override knurled knob counterclockwise until it stops. The override will remain activated until the knob is turned clockwise to original position. The manual override option is intended for emergency use, not for continuous duty operation.

Features

- Screw type manual override

Specifications

Operating Pressure	5000 psi (350 bar)
Nominal Flow	8.4 gpm at 5000 psi (32 l/min at 350 bar)
Internal Leakage	6 cu in/min. at 3600 psi and 158 SUS (100 cc/min at 250 bar and 34 cSt)
Fluid Operating Temp. Range	-4° to 248°F (-20° to 120°C) (Consult factory for usage at temp. outside range.)
Ambient Temperature Range	-4° to 140°F (-20° to 60°C)
Coil Duty Rating	Continuous from 85% to 115% of nominal voltage
Current Draw @ 68°F (20°C)	2.22 A at 12VDC; 1.13 A at 24VDC
Min. Pull-in Voltage @ 68°F (20°C)	85% of nominal @ 5000 psi (350 bar)
Fluid Compatibility	Mineral-based or synthetics with lubricating properties
Viscosity	50 to 2000 SUS (7.4 to 420 cSt)
Filtration	21/19/16 or cleaner (per ISO 4406). Use with filter rated $\beta_{10} \geq 200$.
Installation	No orientation restrictions
Cavity	FC10-4 (see <i>Line Bodies & Cavities</i> section)
Cavity Tools	Rougher: 02580248 Finisher: 02580249
Cartridge Weight	0.55 Lbs. (0.25 kg)
Coil Weight	0.51 Lbs. (0.23 kg)
Cartridge Material	Steel with hardened work surfaces. Zinc-plated exposed surfaces. Buna N or Viton® o-rings. PTFE back-up rings.
Coil Material	Class N high temperature magnet wire, steel shell, polyamid encapsulation.
Seal Kits	Buna-N FS104-N P/N: 03051912 Viton® FS104-V P/N: 03071275

Performance

Measured at 158 SUS (34 cSt)
 $T_{oil} = 115^{\circ}\text{F}$ (46°C)

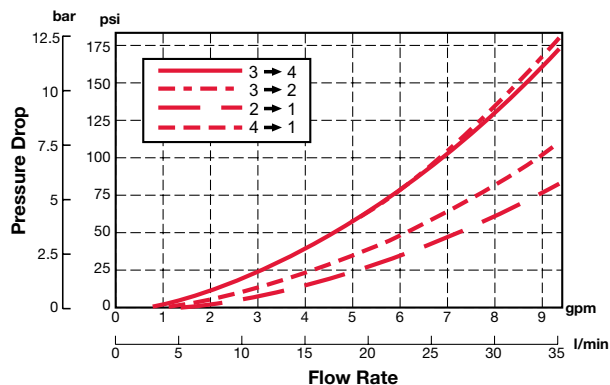

Dimensions

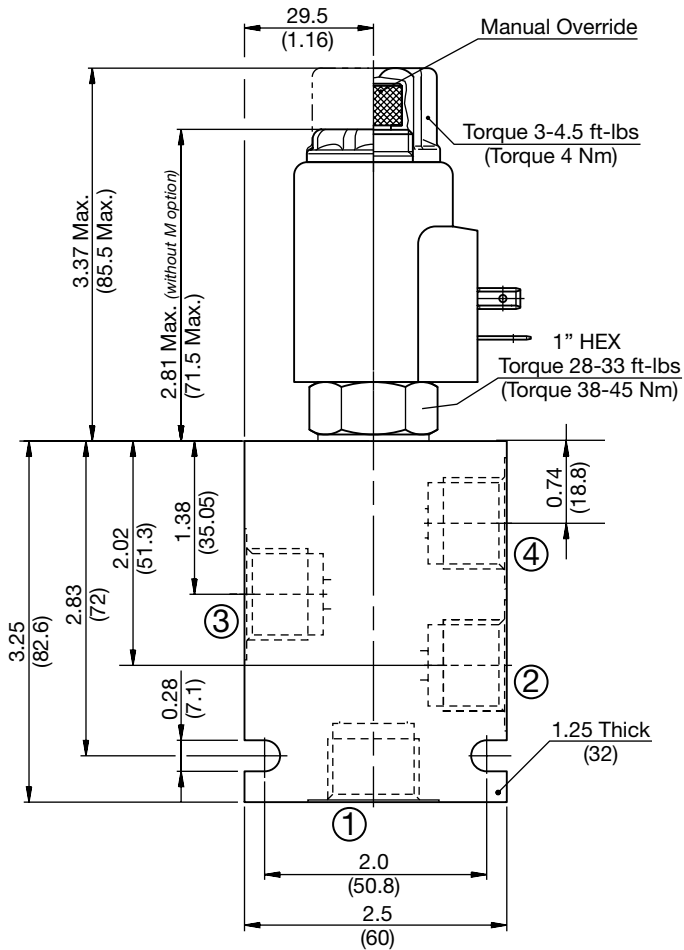

Model Code

WK10X-01 M-C-N-24 DN

- Valve Model** _____
- Override Option** _____
 blank = No manual override
 M = Manual override, screw type
- Body & Ports** _____
 C = Cartridge only
 AS8 = SAE-8 Ports, aluminum body
 SS8 = SAE-8 Ports, steel body
- Seals** _____
 N = Buna-N
 V = Viton®
- Coil Voltage** _____
 0 = No coil, cartridge only
- DC** _____
 12 = 12 VDC
 24 = 24 VDC
 36 = 36 VDC
 110 = 110 VDC (only available with connector DG)
- AC** _____
 24 = 24 VAC
 115 = 115 VAC (AC coils internally full wave rectified)
 230 = 230 VAC
- Coil Connector** _____
 DC DG = EN 175301-803
 DS = Dual spade (SAEJ858a)*
 DL = Leadwires (2) - 18" long (46 cm)*
 DW = WeatherPak™ on leadwires - 9.5" long (24 cm)*
 DN = Deutsch™ DT04-2P, molded, axial (IP69K Rated)*
 DT = Amp Junior Timer™, molded, radial mount*
- AC AG** = EN 175301-803
- Coil Model** 50-1836
 For other coil connector types consult factory
- *Coils with internal diode are available, consult factory.

All measurements in inches (mm).
 Subject to technical modifications

PN#02087369 / 10.19 / CHD1110-1389

Standard Line Bodies*

Code	Part No	Material	Pressure Rating	Weight
FH104-AS8	03038110	Aluminum, anodized	3500 psi (245 bar)	0.72 lbs (0.33 kg)
FH104-SS8	03037868	Steel, zinc plated	6000 psi (420 bar)	2.12 lbs (0.96 kg)

*Please refer to Line Bodies & Cavities section for details

SOLENOID VALVES

WK06Y-01

Spool Type, Direct Acting

Up to 2 gpm (7.6 l/min) • 5000 psi (350 bar)

Hydraulic Symbol

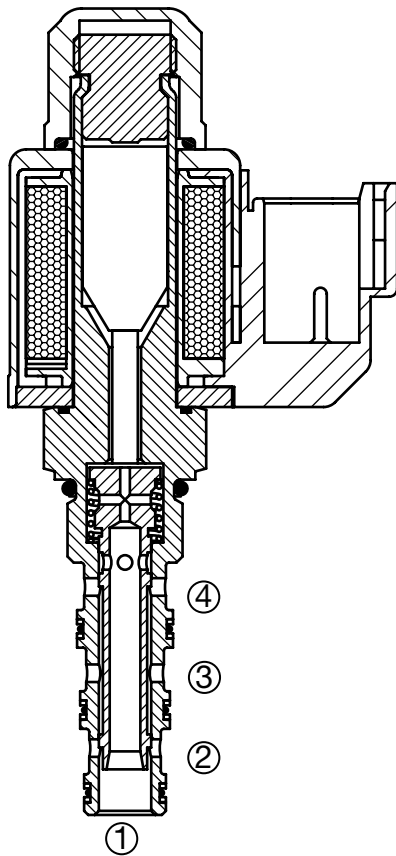
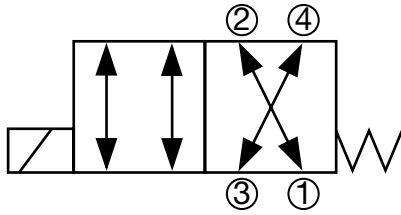

Description

A screw-in cartridge, solenoid operated, 4 way 2 position, direct acting, spool type valve.

Operation

When de-energized the WK06Y allows flow from port 2 to port 1 bi-directionally and port 3 to port 4 bi-directionally. When energized the spool shifts and opens flow from port 2 to port 3 bi-directionally and from port 4 to port 1

Specifications

Operating Pressure	5000 psi (350 bar)
Nominal Flow	2 gpm (7.6 l/min)
Nominal Pressure	Up to 5000 psi. (350 bar), 3000 psi (207 bar) max on tank (port 1)
Internal Leakage	6.0 cu in/min. at 3000 psi and 135 SUS (100 cc/min at 207 bar and 38 cSt)
Fluid Operating Temp. Range	-20° to 248°F (-29° to 120°C)
Ambient Temperature Range	-20° to 140°F (-29° to 60°C)
Coil Duty Rating	Continuous from 85% to 115% of nominal voltage
Current Draw at 68°F (20°C)	984 mA at 12VDC; 492 mA at 24VDC
Min. Pull-in Current to Operate Valve	70% of nominal amperage
Typical Response Time (Varies with Pressure and Flow)	On: 30 to 60 ms Off: 20 to 40 ms
Fluid Compatibility	Mineral-Based or Synthetics with lubricating properties.
Viscosity	50 to 2000 SUS (7.4 to 420 cSt)
Filtration	21/19/16 or cleaner per (ISO 4406)
Installation	No orientation restrictions
Cavity	FC06-4 (see Line Bodies & Cavities section)
Cavity Tools	Rougher: 02582057 Finisher: 02582058
Cartridge Weight	3.6 oz (102 grams)
Coil Weight	3.1 oz (88 grams)
Cartridge Material	Steel with hardened work surfaces. Zinc plated exposed surfaces. Buna N or Viton® o-rings. Solid thermoplastic polyester back-up rings.
Coil Material	Class N, 200°C high temperature magnet wire, steel shell, polyester encapsulation.
Seal Kits	Buna-N FS064-N P/N: 02610188 Viton® FS064-V P/N: 02610189

Performance

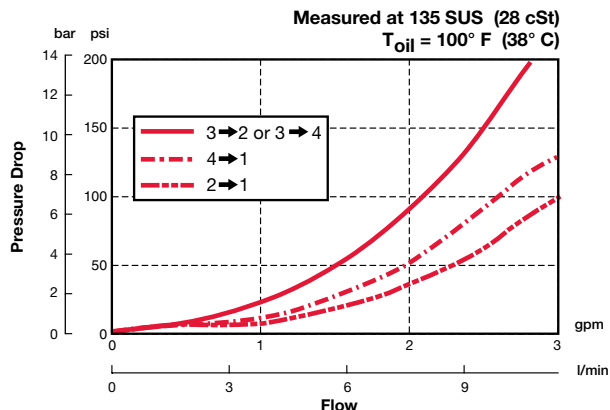

Dimensions

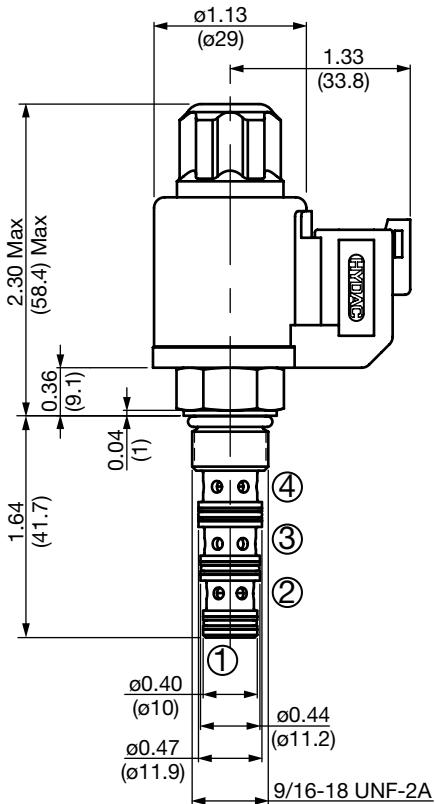
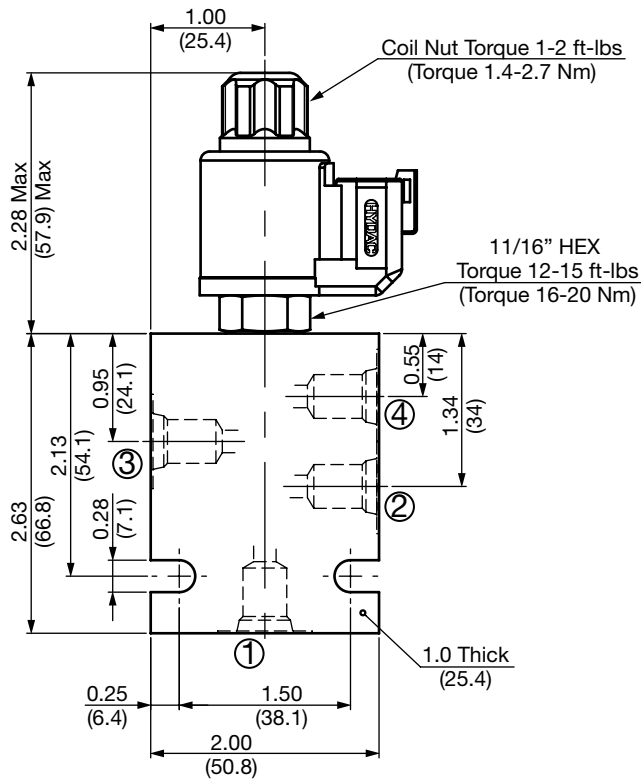

All measurements in inches (mm).
Subject to technical modifications

PN#02087369 / 10.19 / CHD1110-1389

Model Code

WK06Y-01 M-C-N-24 DN

Valve Model

Override Option

- blank = No manual override
- M = Manual override, push type
(for availability consult factory)

Body & Ports

- C = Cartridge only
- AS4 = SAE-4 Ports, aluminum body
- SS4 = SAE-4 Ports, steel body

Seals

- N = Buna-N
- V = Viton®

Coil Voltage

- 0 = No coil, cartridge only
- DC 12 = 12 VDC
- DC 24 = 24 VDC
- AC 115 = 105 VDC (only available with connector DG)
- AC 230 = 205 VDC (only available with connector DG)

(All model 32-1329 coils are DC. AC models require an external diode bridge mounted outside the coil)**

Coil Connector

- DG = EN 175301-803-B (IP65 Rated)**
- DC DL = Leadwires (2) - 18" long (46 cm) AWG18, TYPE UL 1815 (IP69K Rated)*
- DN = Deutsch DT04-2P integral molded (IP69K Rated)*

Use mating plug EN 175301-803-B without diode bridge for DC voltages P/N 02600570

Use mating plug EN 175301-803-B w/diode bridge for AC voltages P/N 02600582

Coil Model 32-1329

For other coil connector types consult factory

** Mating Plugs sold separately

*Coils with internal transient suppression diode are available, consult factory.

Operating Limits

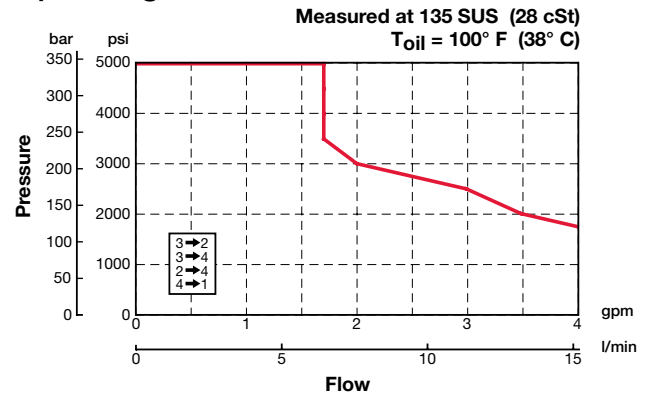

Standard Line Bodies*

Code	Part No	Material	Pressure Rating	Weight
FH064-AS4	02600462	Aluminum, anodized	3500 psi (245 bar)	0.43 lbs (0.20 kg)
FH064-SS4	02600461	Steel, zinc plated	6000 psi (420 bar)	1.25 lbs (0.57 kg)

*Please refer to Line Bodies & Cavities section for details

SOLENOID VALVES

WK08Y-01

Spool Type, Direct Acting

Up to 5 gpm (19 l/min) • 5000 psi (350 bar)

Hydraulic Symbol

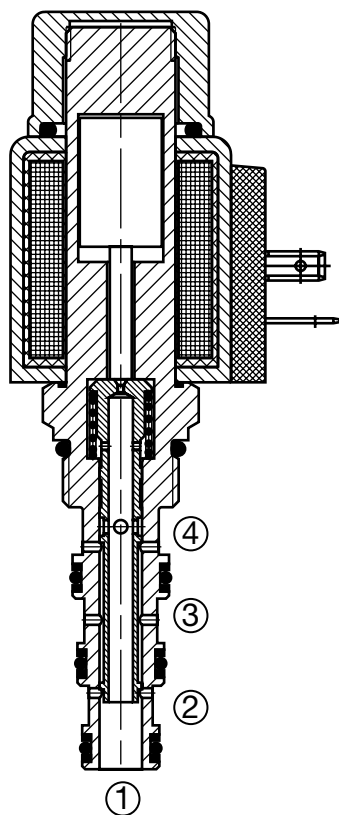
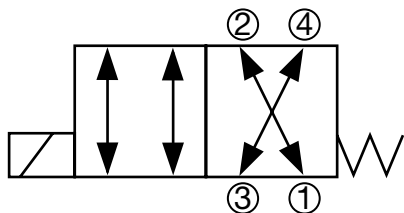

Description

A screw-in cartridge, solenoid operated, 4-way, 2 position, direct acting, spool type valve.

Operation

When de-energized the WK08Y allows flow from port 2 to port 1 bi-directionally and port 3 to port 4 bi-directionally. When energized the spool shifts and opens flow from port 2 to port 3 bi-directionally and from port 4 to port 1.

Operation of Manual Override Option: To override, push and hold the override button. The override is not detented. The manual override option is intended for emergency use, not for continuous duty operation.

Features

- Push type manual override button, protected by rubber cap

Specifications

Operating Pressure	5000 psi (350 bar)
Nominal Flow	5 gpm at 3600 psi (19 l/min at 250 bar)
Internal Leakage	5 cu in/min. at 3600 psi and 158 SUS (82 cc/min at 250 bar and 34 cSt)
Fluid Operating Temp. Range	-4° to 248°F (-20° to 120°C) <i>(Consult factory for usage at temp. outside range.)</i>
Ambient Temperature Range	-4° to 140°F (-20° to 60°C)
Coil Duty Rating	Continuous from 85% to 115% of nominal voltage
Current Draw @ 68°F (20°C)	1.5 A at 12VDC; 0.8 A at 24VDC
Min. Pull-in Voltage @ 68°F (20°C)	85% of nominal @ 5000 psi (350 bar)
Fluid Compatibility	Mineral-based or synthetics with lubricating properties
Viscosity	50 to 2000 SUS (7.4 to 420 cSt)
Filtration	21/19/16 or cleaner (per ISO 4406). Use with filter rated B10 ≥ 200.
Installation	No orientation restrictions
Cavity	FC08-4 (see <i>Line Bodies & Cavities</i> section)
Cavity Tools	Rougher: 02580088 Finisher: 02580089
Cartridge Weight	0.42 Lbs. (0.19 kg)
Coil Weight	0.42 Lbs. (0.19 kg)
Cartridge Material	Steel with hardened work surfaces. Zinc-plated exposed surfaces. Buna N or Viton® o-rings. PTFE back-up rings.
Coil Material	Class N high temperature magnet wire, steel shell, polyamid encapsulation.
Seal Kits	Buna-N P/N: 03071272 Viton® P/N: 03071273

Performance

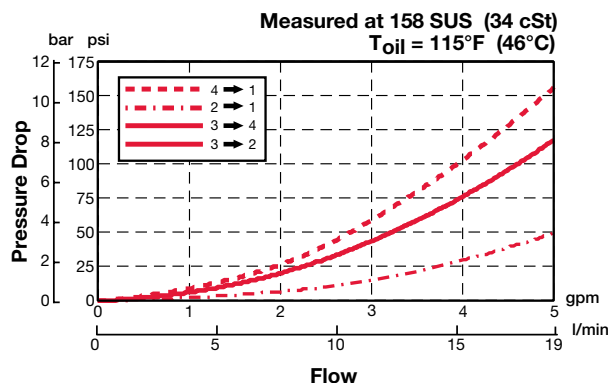

Dimensions

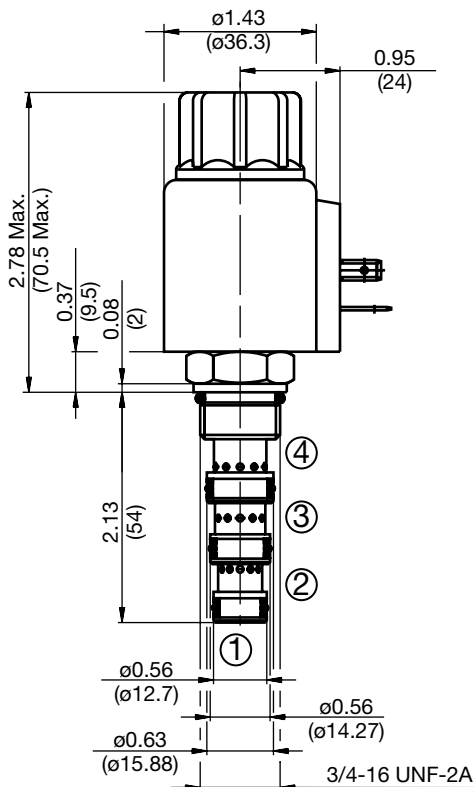
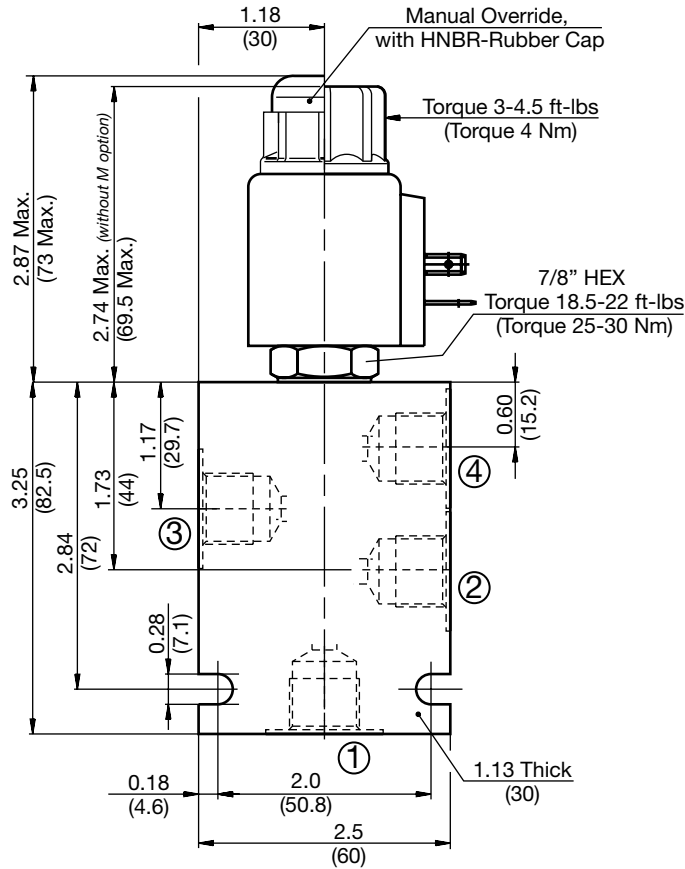

All measurements in inches (mm).
Subject to technical modifications

Model Code

WK08Y-01 M-C-N-24 DN

- Valve Model** _____
- Override Option** _____
blank = No manual override
M = Manual override, push type
- Body & Ports** _____
C = Cartridge only
AS6 = SAE-6 Ports, aluminum body
SS6 = SAE-6 Ports, steel body
- Seals** _____
N = Buna-N
V = Viton®
- Coil Voltage** _____
0 = No coil, cartridge only
- DC** _____
12 = 12 VDC
24 = 24 VDC
36 = 36 VDC
110 = 110 VDC (only available with connector DG)
- AC** _____
24 = 24 VAC
115 = 115 VAC (AC coils internally full wave rectified)
230 = 230 VAC
- Coil Connector** _____
DC DG = EN 175301-803-A
DS = Dual spade (SAEJ858a)*
DL = Leadwires (2) - 18" long (46 cm)*
DW = WeatherPak™ on leadwires - 9.5" long (24 cm)*
DN = Deutsch™ DT04-2P, molded, axial (IP69K Rated)*
DT = Amp Junior Timer™, molded, radial mount*
- AC AG** = EN 175301-803-A
- Coil Model** 40-1836
For other coil connector types consult factory
- *Coils with internal diode are available, consult factory.

Operating Limits

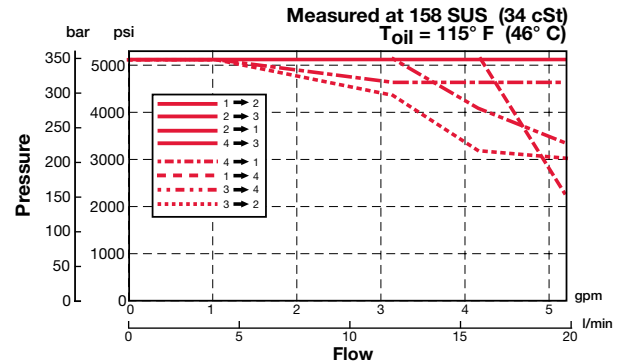

Standard Line Bodies*

Code	Part No	Material	Pressure Rating	Weight
FH084-AS6	03011404	Aluminum, anodized	3500 psi (245 bar)	0.72 lbs (0.33 kg)
FH084-SS6	00563381	Steel, zinc plated	6000 psi (420 bar)	2.12 lbs (0.96 kg)

*Please refer to Line Bodies & Cavities section for details

SOLENOID VALVES

WK10Y-01

Spool Type, Direct Acting

Up to 8.4 gpm (32 l/min) • 5000 psi (350 bar)

Hydraulic Symbol

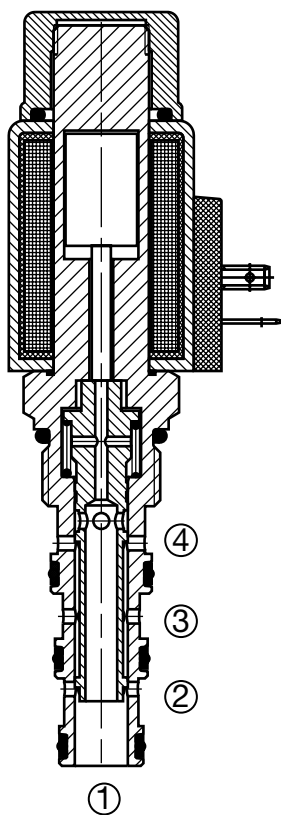
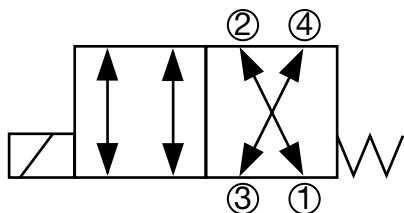

Description

A screw-in cartridge, solenoid operated, 4-way, 2 position, direct acting, spool type valve.

Operation

When de-energized the WK10Y allows flow from port 2 to port 1 bi-directionally and port 3 to port 4 bi-directionally. When energized the spool shifts and opens flow from port 2 to port 3 bi-directionally and from port 4 to port 1.

Operation of Manual Override Option: To override, push and hold the override button. The override is not detented. The manual override option is intended for emergency use, not for continuous duty operation.

Features

- Push type manual override button, protected by rubber cap

Specifications

Operating Pressure	5000 psi (350 bar)
Nominal Flow	8.4 gpm at 5000 psi (32 l/min at 350 bar)
Internal Leakage	7.3 cu in/min. at 3600 psi and 158 SUS (120 cc/min at 250 bar and 34 cSt)
Fluid Operating Temp. Range	-4° to 248°F (-20° to 120°C) <i>(Consult factory for usage at temp. outside range.)</i>
Ambient Temperature Range	-4° to 140°F (-20° to 60°C)
Coil Duty Rating	Continuous from 85% to 115% of nominal voltage
Current Draw @ 68°F (20°C)	2.22 A at 12VDC; 1.13 A at 24VDC
Min. Pull-in Voltage @ 68°F (20°C)	85% of nominal @ 5000 psi (350 bar)
Fluid Compatibility	Mineral-based or synthetics with lubricating properties
Viscosity	50 to 2000 SUS (7.4 to 420 cSt)
Filtration	21/19/16 or cleaner (per ISO 4406). Use with filter rated B10 ≥ 200.
Installation	No orientation restrictions
Cavity	FC10-4 (see <i>Line Bodies & Cavities</i> section)
Cavity Tools	Rougher: 02580248 Finisher: 02580249
Cartridge Weight	0.55 Lbs. (0.25 kg)
Coil Weight	0.51 Lbs. (0.23 kg)
Cartridge Material	Steel with hardened work surfaces. Zinc-plated exposed surfaces. Buna N or Viton® o-rings. PTFE back-up rings.
Coil Material	Class N high temperature magnet wire, steel shell, polyamid encapsulation.
Seal Kits	Buna-N P/N: 03051912 Viton® P/N: 03071275

Performance

Measured at 158 SUS (34 cSt)
T_{oil} = 115°F (46°C)

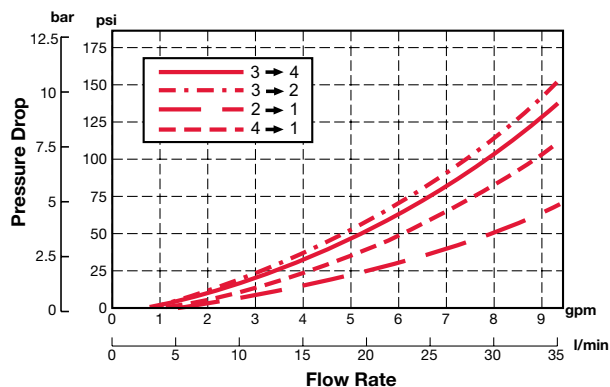

Dimensions

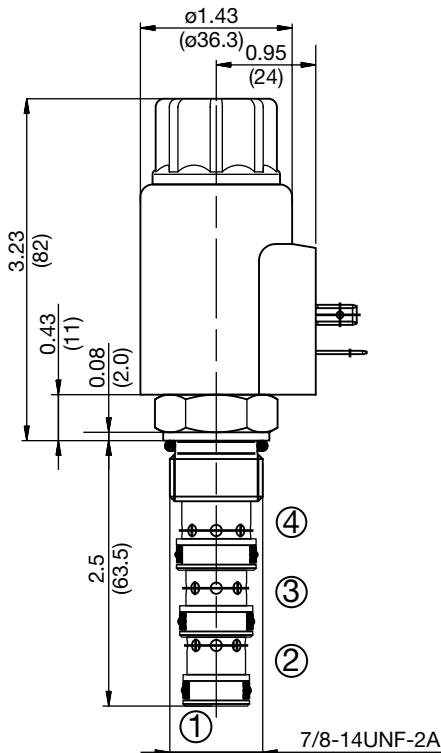
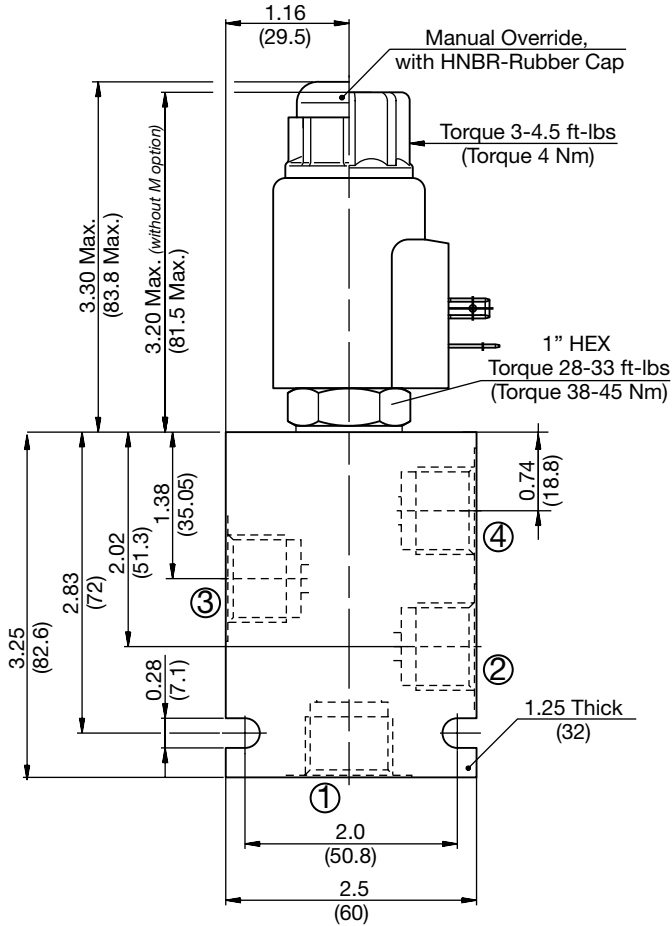

All measurements in inches (mm).
Subject to technical modifications

Model Code

WK10Y-01 M-C-N-24 DN

- Valve Model** _____
- Override Option** _____
blank = No manual override
M = Manual override, push type
- Body & Ports** _____
C = Cartridge only
AS8 = SAE-8 Ports, aluminum body
SS8 = SAE-8 Ports, steel body
- Seals** _____
N = Buna-N
V = Viton®
- Coil Voltage** _____
0 = No coil, cartridge only
DC 12 = 12 VDC
24 = 24 VDC
36 = 36 VDC
110 = 110 VDC (only available with connector DG)
AC 24 = 24 VAC
115 = 115 VAC (AC coils internally full wave rectified)
230 = 230 VAC
- Coil Connector** _____
DC DG = EN 175301-803-A
DS = Dual spade (SAEJ858a)*
DL = Leadwires (2) - 18" long (46 cm)*
DW = WeatherPak™ on leadwires - 9.5" long (24 cm)*
DN = Deutsch™ DT04-2P, molded, axial (IP69K Rated)*
DT = Amp Junior Timer™, molded, radial mount*
AC AG = DIN 175301-803-A

Coil Model 50-1836

For other coil connector types consult factory

*Coils with internal diode are available, consult factory.

Standard Line Bodies*

Code	Part No	Material	Pressure Rating	Weight
FH104-AS8	03038110	Aluminum, anodized	3500 psi (245 bar)	0.72 lbs (0.33 kg)
FH104-SS8	03037868	Steel, zinc plated	6000 psi (420 bar)	2.12 lbs (0.96 kg)

*Please refer to Line Bodies & Cavities section for details

SOLENOID VALVES

WK08Z-01

Spool Type, Direct Acting

Up to 4.5 gpm (17 l/min) • 5000 psi (350 bar)

Hydraulic Symbol

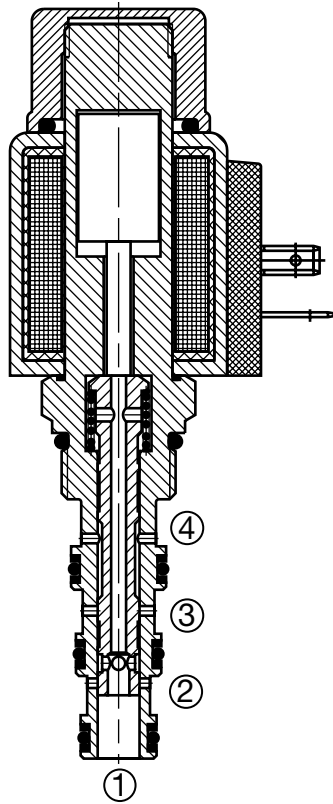
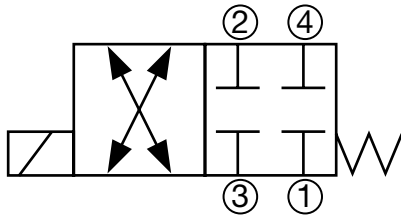

Description

A screw-in cartridge, solenoid operated, 4-way, 2 position, direct acting, spool type valve.

Operation

When de-energized the WK08Z blocks flow at all ports. When energized the spool shifts and allows flow from port 1 to port 2 bi-directionally and from port 3 to port 4 bi-directionally.

Operation of Manual Override Option: To override, push and hold the override button. The override is not detented. The manual override option is intended for emergency use, not for continuous duty operation.

Features

- Push type manual override button, protected by rubber cap

Specifications

Operating Pressure	5000 psi (350 bar)
Nominal Flow	4.5 gpm at 3600 psi (17 l/min at 250 bar) 2 gpm at 5000 psi (7.6 l/min at 350 bar)
Internal Leakage	5.5 cu in/min. at 3600 psi and 158 SUS (90 cc/min at 250 bar and 34 cSt)
Fluid Operating Temp. Range	-4° to 248°F (-20° to 120°C) (Consult factory for usage at temp. outside range.)
Ambient Temperature Range	-4° to 140°F (-20° to 60°C)
Coil Duty Rating	Continuous from 85% to 115% of nominal voltage
Current Draw @ 68°F (20°C)	1.5 A at 12VDC; 0.8 A at 24VDC
Min. Pull-in Voltage @ 68°F (20°C)	85% of nominal @ 5000 psi (350 bar)
Fluid Compatibility	Mineral-based or synthetics with lubricating properties
Viscosity	50 to 2000 SUS (7.4 to 420 cSt)
Filtration	21/19/16 or cleaner (per ISO 4406). Use with filter rated $\beta_{10} \geq 200$.
Installation	No orientation restrictions
Cavity	FC08-4 (see <i>Line Bodies & Cavities</i> section)
Cavity Tools	Rougher: 02580088 Finisher: 02580089
Cartridge Weight	0.42 Lbs. (0.19 kg)
Coil Weight	0.42 Lbs. (0.19 kg)
Cartridge Material	Steel with hardened work surfaces. Zinc-plated exposed surfaces. Buna N or Viton® o-rings. PTFE back-up rings.
Coil Material	Class N high temperature magnet wire, steel shell, polyamid encapsulation.
Seal Kits	Buna-N P/N: 03071272 Viton® P/N: 03071273

Performance

Measured at 158 SUS (34 cSt)
 $T_{oil} = 115^{\circ}F (46^{\circ}C)$

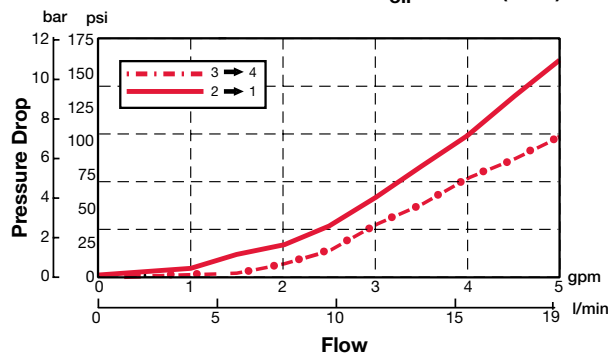

Dimensions

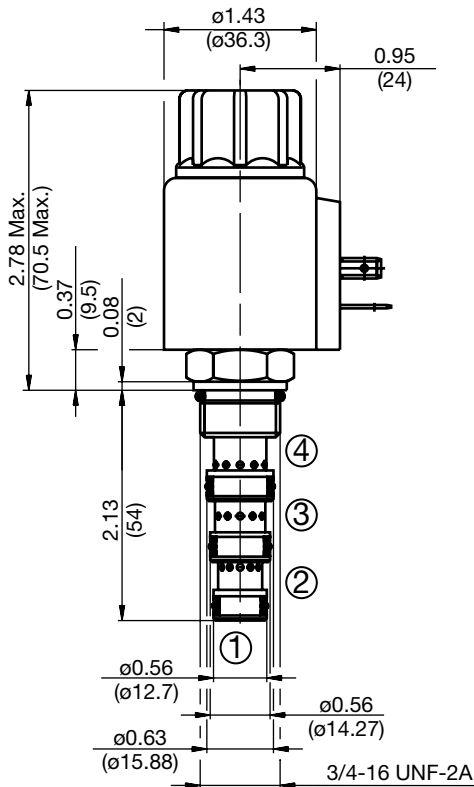
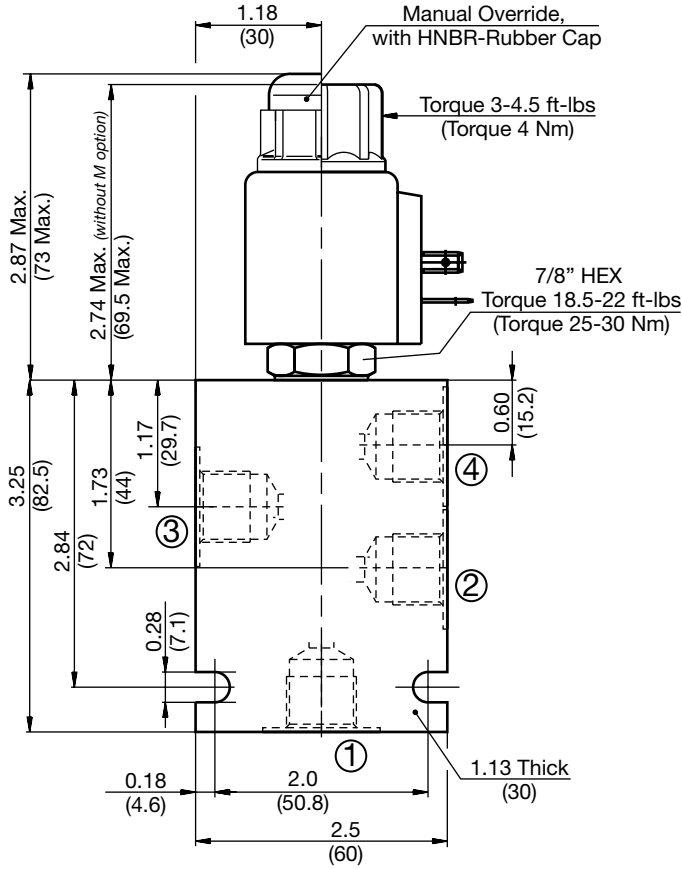

All measurements in inches (mm).
Subject to technical modifications

PN#02087369 / 10.19 / CHD1110-1389

Model Code

WK08Z-01 M-C-N-24 DN

Valve Model _____

Override Option _____
 blank = No manual override
 M = Manual override, push type

Body & Ports _____
 C = Cartridge only
 AS6 = SAE-6 Ports, aluminum body
 SS6 = SAE-6 Ports, steel body

Seals _____
 N = Buna-N
 V = Viton®

Coil Voltage _____
 0 = No coil, cartridge only

DC _____
 12 = 12 VDC
 24 = 24 VDC
 36 = 36 VDC
 110 = 110 VDC (only available with connector DG)

AC _____
 24 = 24 VAC
 115 = 115 VAC (AC coils internally full wave rectified)
 230 = 230 VAC

Coil Connector _____
 DC DG = EN 175301-803-A
 DS = Dual spade (SAEJ858a)*
 DL = Leadwires (2) - 18" long (46 cm)*
 DW = WeatherPak™ on leadwires - 9.5" long (24 cm)*
 DN = Deutsch™ DT04-2P, molded, axial (IP69K Rated)*
 DT = Amp Junior Timer™, molded, radial mount*

AC AG = EN 175301-803-A

Coil Model 40-1836
 For other coil connector types consult factory

*Coils with internal diode are available, consult factory.

Standard Line Bodies*

Code	Part No	Material	Pressure Rating	Weight
FH084-AS6	03011404	Aluminum, anodized	3500 psi (245 bar)	0.72 lbs (0.33 kg)
FH084-SS6	00563381	Steel, zinc plated	6000 psi (420 bar)	2.12 lbs (0.96 kg)

*Please refer to Line Bodies & Cavities section for details

SOLENOID VALVES

WK10Z-01

Spool Type, Direct Acting

Up to 8.4 gpm (32 l/min) • 5000 psi (350 bar)

Hydraulic Symbol

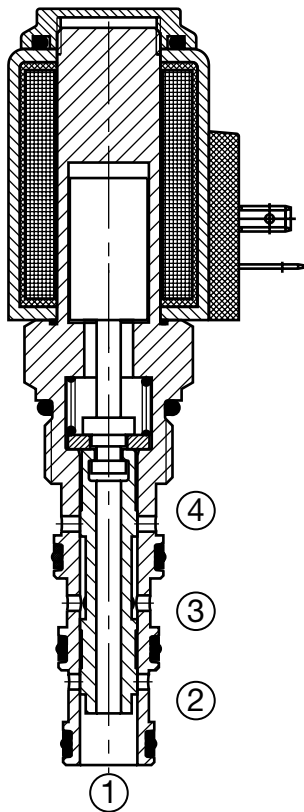
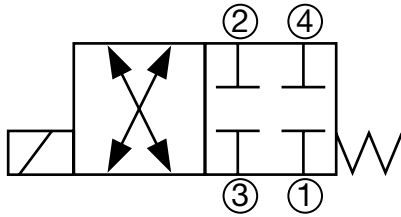

Description

A screw-in cartridge, solenoid operated, 4-way, 2 position, direct acting, spool type valve.

Operation

When de-energized the WK10Z blocks flow at all ports. When energized the spool shifts and allows flow from port 1 to port 2 bi-directionally and from port 3 to port 4 bi-directionally.

Operation of Manual Override Option: To override, remove the coil nut, turn the override knurled knob counterclockwise until it stops. The override will remain activated until the knob is turned clockwise to original position. The manual override option is intended for emergency use, not for continuous duty operation.

Features

- Screw type manual override

Specifications

Operating Pressure	5000 psi (350 bar)
Nominal Flow	8.4 gpm at 5000 psi (32 l/min at 350 bar)
Internal Leakage	6 cu in/min. at 3600 psi and 158 SUS (100 cc/min at 250 bar and 34 cSt)
Fluid Operating Temp. Range	-4° to 248°F (-20° to 120°C) (Consult factory for usage at temp. outside range.)
Ambient Temperature Range	-4° to 140°F (-20° to 60°C)
Coil Duty Rating	Continuous from 85% to 115% of nominal voltage
Current Draw @ 68°F (20°C)	1.5 A at 12VDC; 0.8 A at 24VDC
Min. Pull-in Voltage @ 68°F (20°C)	90% of nominal @ 5000 psi (350 bar)
Fluid Compatibility	Mineral-based or synthetics with lubricating properties
Viscosity	50 to 2000 SUS (7.4 to 420 cSt)
Filtration	21/19/16 or cleaner (per ISO 4406). Use with filter rated $\beta_{10} \geq 200$.
Installation	No orientation restrictions
Cavity	FC10-4 (see <i>Line Bodies & Cavities</i> section)
Cavity Tools	Rougher: 02580248 Finisher: 02580249
Cartridge Weight	0.64 Lbs. (0.29 kg)
Coil Weight	0.42 Lbs. (0.19 kg)
Cartridge Material	Steel with hardened work surfaces. Zinc-plated exposed surfaces. Buna N or Viton® o-rings. PTFE back-up rings.
Coil Material	Class N high temperature magnet wire, steel shell, polyamid encapsulation.
Seal Kits	Buna-N FS104-N P/N: 03051912 Viton® FS104-V P/N: 03071275

Performance

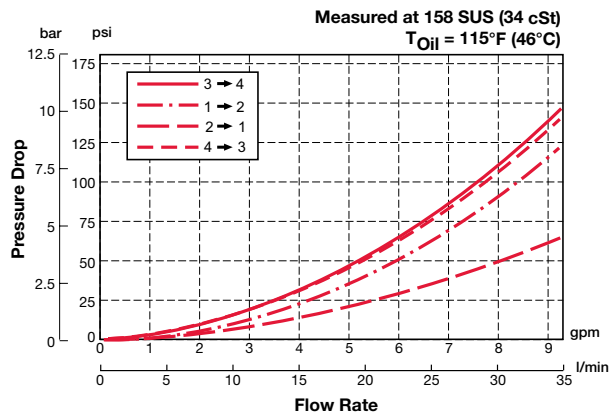

Dimensions

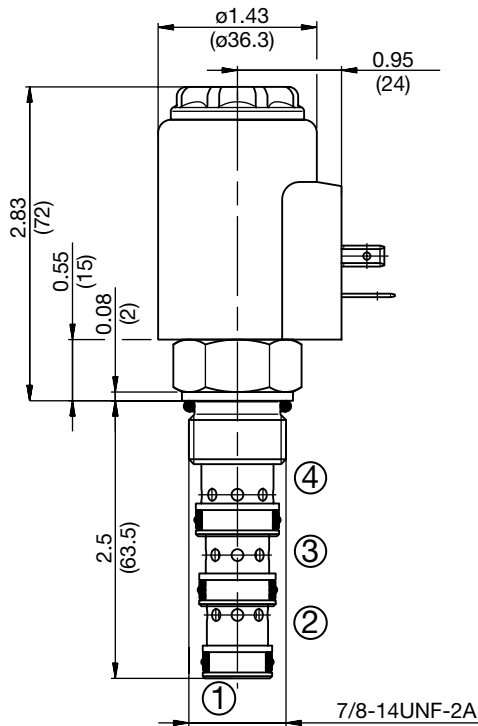
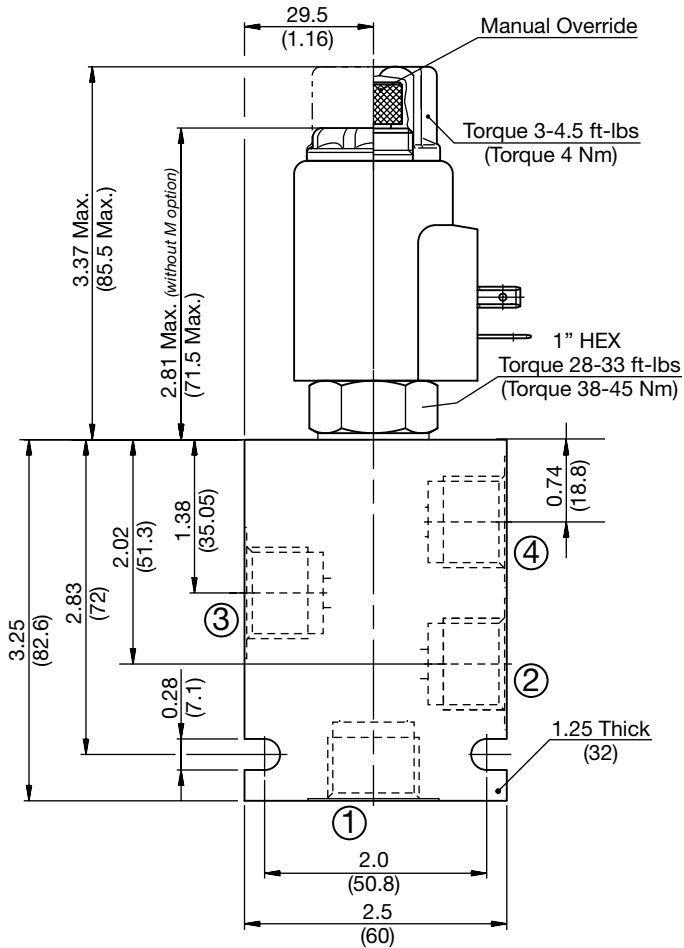

Model Code

WK10Z-01 M-C-N-24 DN

Valve Model

Override Option

- blank = No manual override
- M = Manual override, screw type

Body & Ports

- C = Cartridge only
- AS8 = SAE-8 Ports, aluminum body
- SS8 = SAE-8 Ports, steel body

Seals

- N = Buna-N
- V = Viton®

Coil Voltage

- 0 = No coil, cartridge only
- DC 12 = 12 VDC
- 24 = 24 VDC
- 36 = 36 VDC
- 110 = 110 VDC (only available with connector DG)
- AC 24 = 24 VAC
- 115 = 115 VAC (AC coils internally full wave rectified)
- 230 = 230 VAC

Coil Connector

- DC DG = EN 175301-803-A
- DS = Dual spade (SAEJ858a)*
- DL = Leadwires (2) - 18" long (46 cm)*
- DW = WeatherPak™ on leadwires - 9.5" long (24 cm)*
- DN = Deutsch™ DT04-2P, molded, axial (IP69K Rated)*
- DT = Amp Junior Timer™, molded, radial mount*
- AC AG = EN 175301-803-A

Coil Model 50-1836

For other coil connector types consult factory

*Coils with internal diode are available, consult factory.

All measurements in inches (mm).
Subject to technical modifications

PN#02087369 / 10.19 / CHD1110-1389

Standard Line Bodies*

Code	Part No	Material	Pressure Rating	Weight
FH104-AS8	03038110	Aluminum, anodized	3500 psi (245 bar)	0.72 lbs (0.33 kg)
FH104-SS8	03037868	Steel, zinc plated	6000 psi (420 bar)	2.12 lbs (0.96 kg)

*Please refer to Line Bodies & Cavities section for details

SOLENOID VALVES

WK06E-01

Spool Type, Direct Acting

Up to 3 gpm (11.4 l/min) • 5000 psi (350 bar)

Hydraulic Symbol

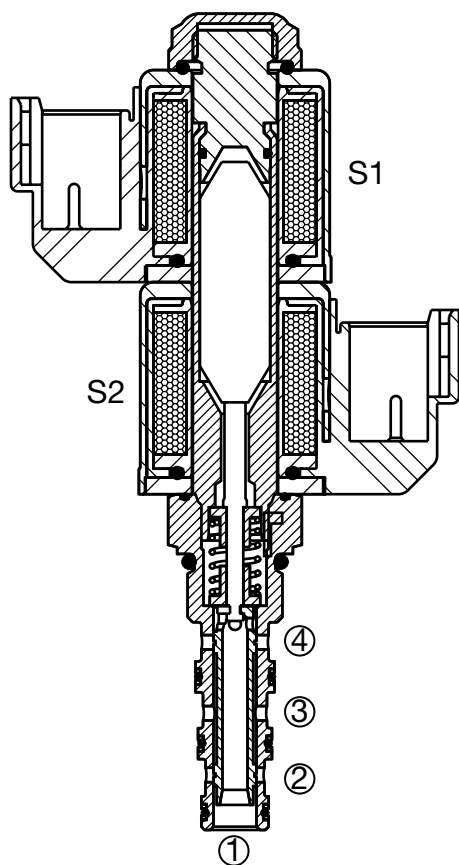
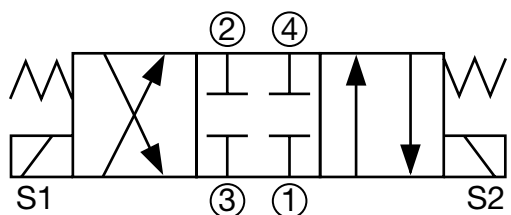

Description

A screw-in cartridge, solenoid operated, 4-way, 3 position, direct acting, spool type valve.

Operation

When de-energized the WK06E blocks flow at all ports. When coil S1 is energized the spool shifts and allows flow from port 2 to port 1 and from port 3 to port 4. When coil S2 is energized the spool shifts and allows flow from port 4 to port 1 and from port 3 to port 2.

Specifications

Operating Pressure	5000 psi (350 bar), 3000 psi (210 bar) Max Port 1
Nominal Flow	See Operating Limits
Internal Leakage	14.0 cu in/min. at 3000 psi and 135 SUS (230 cc/min at 207 bar and 28 cSt)
Fluid Operating Temp. Range	-20° to 248°F (-29° to 120°C)
Ambient Temperature Range	-20° to 140°F (-29° to 60°C)
Coil Duty Rating	Continuous from 85% to 115% of nominal voltage
Current Draw at 68°F (20°C)	984 mA at 12VDC; 492 mA at 24VDC
Min. Pull-in Current to Operate Valve	70% of nominal amperage
Fluid Compatibility	Mineral-Based or Synthetics with lubricating properties
Viscosity	50 to 2000 SUS (7.4 to 420 cSt)
Filtration	21/19/16 or cleaner per (ISO 4406)
Installation	No orientation restrictions
Cavity	FC06-4 (see <i>Line Bodies & Cavities</i> section)
Cavity Tools	Rougher: 02582057 Finisher: 02582058
Cartridge Weight	3.6 oz (102 grams)
Coil Weight	3.1 oz (88 grams) each (2 required)
Cartridge Material	Steel with hardened work surfaces. Zinc plated exposed surfaces. Buna N or Viton® o-rings. Solid thermoplastic polyester back-up rings.
Coil Material	Class N, 200°C high temperature magnet wire, steel shell, polyester encapsulation.
Seal Kits	Buna-N P/N: 02610188 Viton® P/N: 02610189

Performance

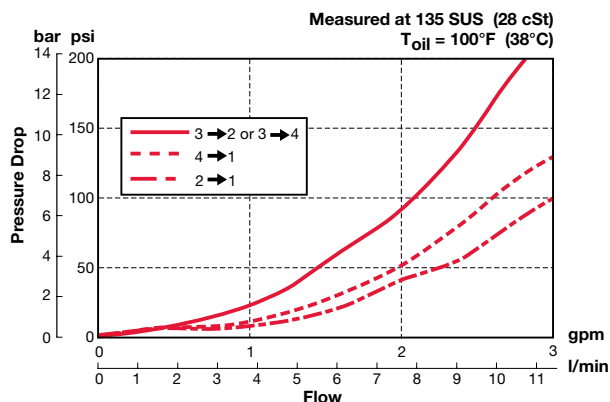

Dimensions

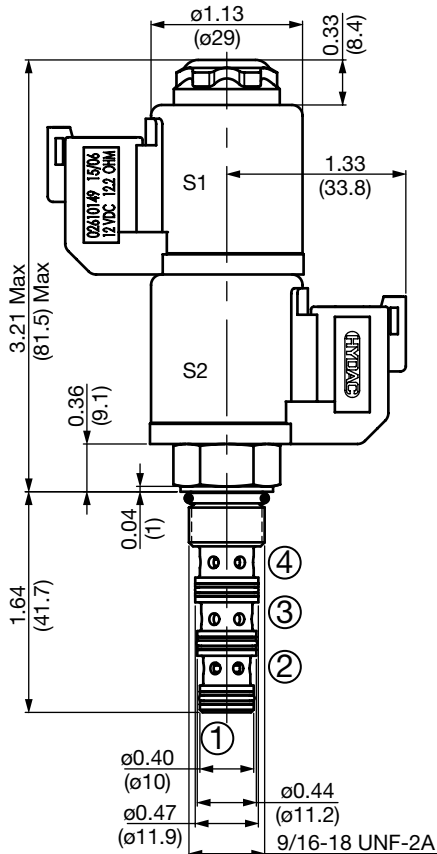
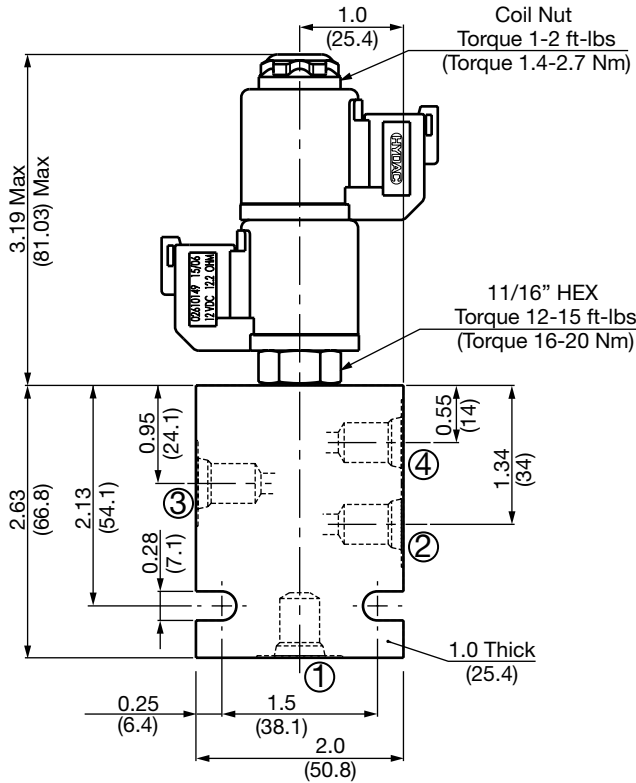

All measurements in inches (mm).
Subject to technical modifications

Model Code

WK06E-01 M-C-N-24 DN

Valve Model

Override Option

- blank = No manual override
- M = Manual override, not detented
- A = Manual override, detented

Body & Ports

- C = Cartridge only
- AS4 = SAE-4 Ports, aluminum Body
- SS4 = SAE-4 Ports, steel Body

Seals

- N = Buna-N
- V = Viton®

Coil Voltage

- 0 = No coil, cartridge only
- DC 12 = 12 VDC
- DC 24 = 24 VDC
- AC 115 = 105 VDC (only available with connector DG)
- AC 230 = 205 VDC (only available with connector DG)

(All model 32-1329 coils are DC. AC models require an external diode bridge mounted outside the coil)**

Coil Connector

- DC DG = EN 175301-803-B (IP65 Rated)**
- DC DL = Leadwires (2) - 18" long (46 cm) AWG18, TYPE UL 1815 (IP69K Rated)*
- DN = Deutsch DT04-2P intergral molded (IP69K Rated)*

Use mating plug EN 175301-803-B without diode bridge for DC voltages P/N 02600570

Use mating plug EN 175301-803-B w/diode bridge for AC voltages P/N 02600582

Coil Model 32-1329

For other coil connector types consult factory

** Mating Plugs sold separately

*Coils with internal transient suppression diode are available, consult factory.

Operating Limits

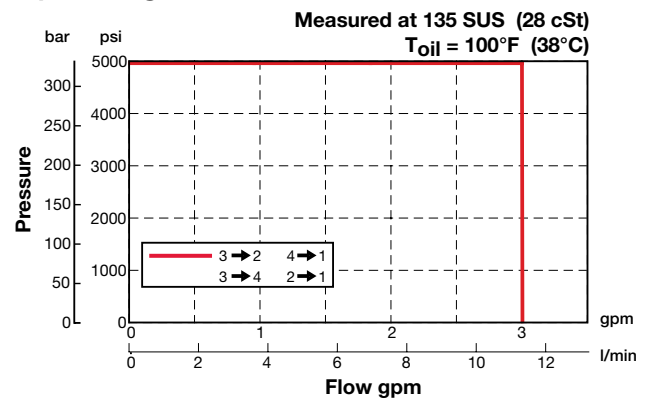

Standard Line Bodies*

Code	Part No	Material	Pressure Rating	Weight
FH064-AS4	02600462	Aluminum, anodized	3500 psi (245 bar)	0.41 lbs (0.19 kg)
FH064-SS4	02600461	Steel, zinc plated	6000 psi (420 bar)	1.22 lbs (0.55 kg)

*Please refer to Line Bodies & Cavities section for details

SOLENOID VALVES

WK08E-01

Spool Type, Direct Acting

Up to 5 gpm (19 l/min) • 5000 psi (350 bar)

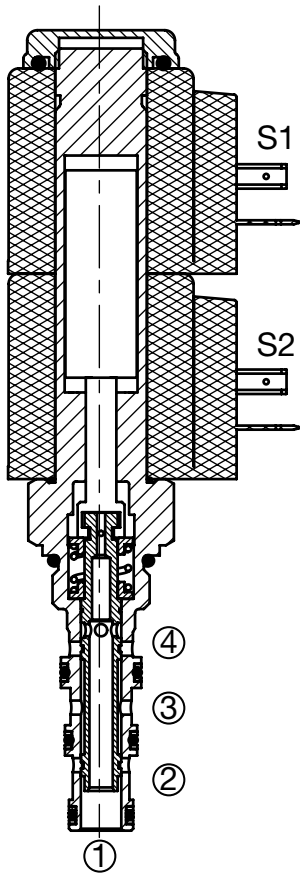

Hydraulic Symbol

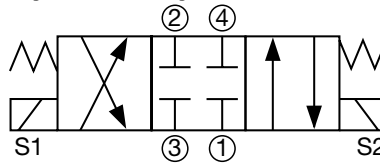

Description

A screw-in cartridge, solenoid operated, 4-way, 3 position, direct acting, spool type valve.

Operation

When de-energized the WK08E blocks flow at all ports. When coil S1 is energized the spool shifts and allows flow from port 1 to port 2 and from port 3 to port 4. When coil S2 is energized the spool shifts and allows flow from port 4 to port 1 and from port 3 to port 2.

Operation of Manual Override Option: To override, twist knurled screw and push or pull to shift spool.

Detented version - twist again after pushing/pulling to hold position.

Features

- Push/pull type manual override button, detented manual override option.
- High flow capacity

Specifications

Operating Pressure	5000 psi (350 bar)
Nominal Flow	5 gpm at 3000 psi (20 l/min@ 210 bar)
Internal Leakage	10 cu in/min. at 3000 psi and 158 SUS (160 cc/min at 210 bar and 34 cSt)
Fluid Operating Temp Range	-20° to 248°F (-29° to 120°C)
Ambient Temperature Range	-20° to 140°F (-29° to 60°C)
Coil Duty Rating	Continuous from 85% to 115% of nominal voltage
Current Draw at 68°F (20°C)	1.5 A at 12VDC; 0.8 A at 24VDC
Minimum Pull-in Current	75% of nominal amperage
Typical Response Time (Varies with Pressure and Flow)	On: 30 to 60 ms Off: 20 to 40 ms
Fluid Compatibility	Mineral-Based or Synthetics with lubricating properties
Viscosity	50 to 2000 SUS (7.4 to 420 cSt)
Filtration	21/19/16 or cleaner per (ISO 4406)
Installation	No orientation restrictions
Cavity	FC08-4 (see <i>Line Bodies & Cavities</i> section)
Cavity Tools	Rougher: 02580088 Finisher: 02580089
Cartridge Weight	0.6 lbs (0.27 kg)
Coil Weight	2 x 0.42 lbs (2 x 0.19 kg)
Cartridge Material	Steel with hardened work surfaces. Zinc plated solenoid tube surface. Buna N or Viton® o-rings Solid thermoplastic polyester back-up rings.
Coil Material	Class N high temperature magnet wire, steel shell, polyamid encapsulation.
Seal Kits	Buna-N FS084-N P/N: 03071272 Viton® FS084-V P/N: 03071273

Performance

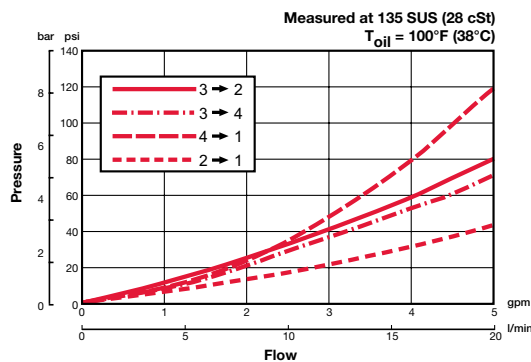

Operating Limits

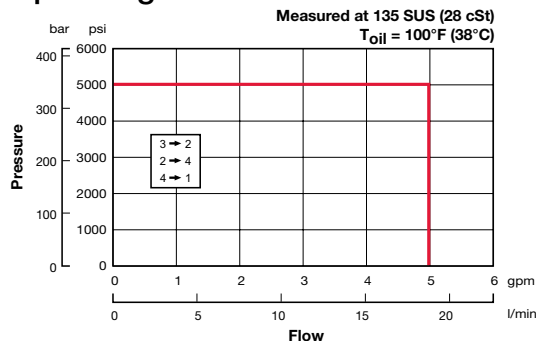

Dimensions

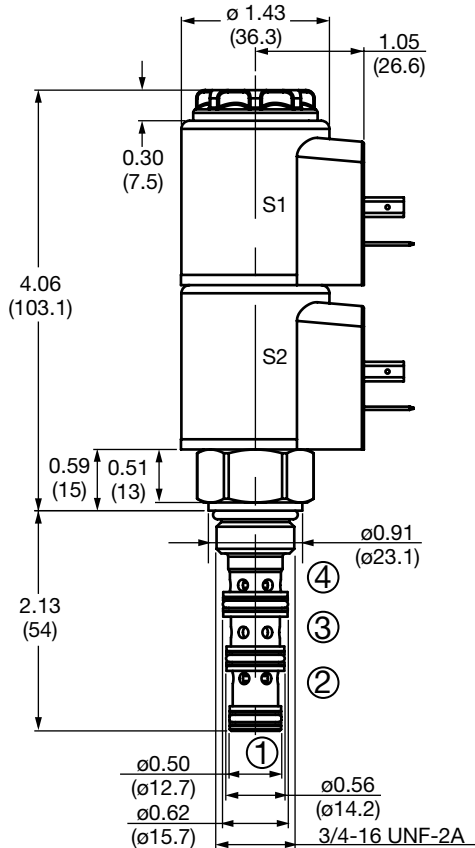
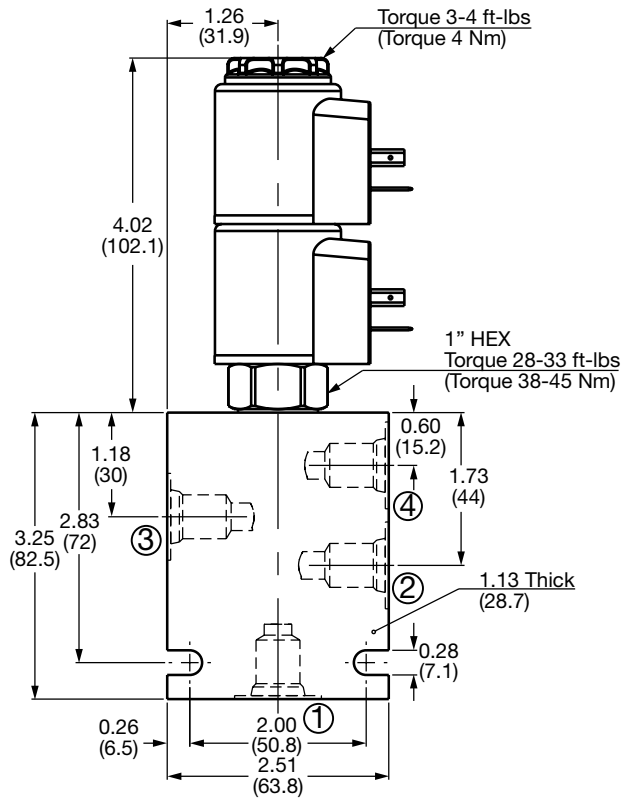

Model Code

WK08E-01-M-C-N-24 DN

- Valve Model** _____
- Override Option** _____
 (omit) = No manual override
 M = Push/pull type, not detented
 A = Push/pull type, detented
- Body & Ports** _____
 C = Cartridge only
 AS6 = SAE-6 ports, aluminum body
 SS6 = SAE-6 ports, steel body
- Seals** _____
 N = Buna-N
 V = Viton®
- Coil Voltage** _____
 0 = No coil, cartridge only
 DC 12 = 12 VDC
 24 = 24 VDC
 36 = 36 VDC
 110 = 110 VDC (only available with connector DG)
- AC** 24 = 24 VAC
 115 = 115 VAC
 230 = 230 VAC
- Coil Connector** _____
 DC DG = EN 175301-803-A
 DS = Dual spade (SAEJ858a)*
 DL = Leadwires (2) - 18" long (46 cm)*
 DW = WeatherPak™ on leadwires - 9.5" long (24 cm)*
 DN = Deutsch™ DT04-2P, molded, axial (IP69K Rated)*
 DT = Amp Junior Timer™, molded, radial mount*
- AC AG** = EN 175301-803-A
- Coil Model** 40-1836, 2 per assembly
 For other coil connector types consult factory
- *Coils with internal diode are available, consult factory.

Manual Override Options

Option M - Non Detented

Option A - Detented

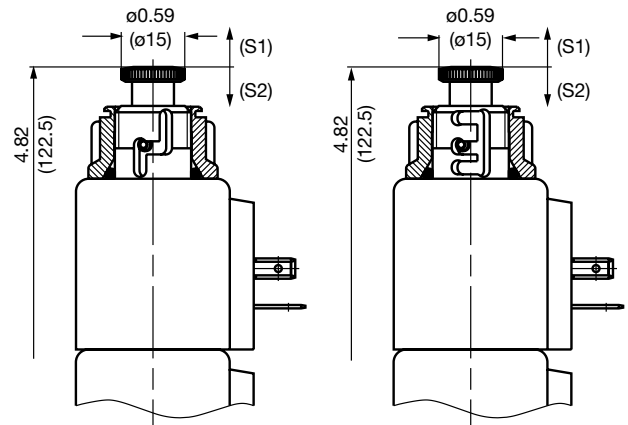

Standard Line Bodies*

Code	Part No	Material	Pressure Rating	Weight
FH084-AS6	03011404	Aluminum, anodized	3500 psi (245 bar)	0.72 lb (0.33 kg)
FH084-SS6	00563381	Steel, zinc plated	6000 psi (420 bar)	2.12 lb (0.96 kg)

*Please refer to Line Bodies & Cavities section for details

All measurements in inches (mm).
 Subject to technical modifications

SOLENOID VALVES

WK10E-01

Spool Type, Direct Acting

Up to 6 gpm (23 l/min) • 5000 psi (350 bar)

Hydraulic Symbol

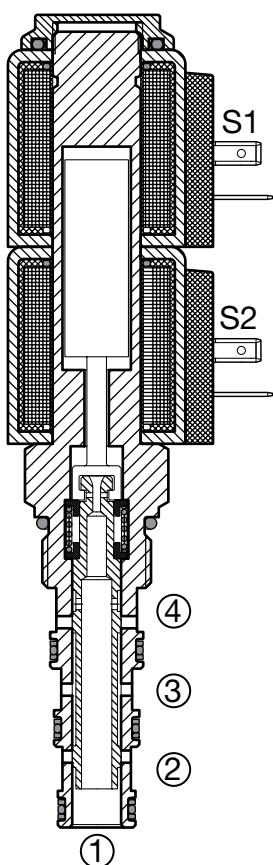
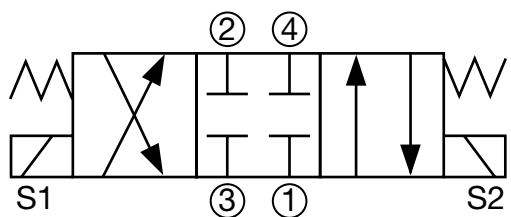

Description

A screw-in cartridge, solenoid operated, 4-way, 3 position, direct acting, spool type valve.

Operation

When de-energized the WK10E blocks flow at all ports. When coil S1 is energized the spool shifts and allows flow from port 1 to port 2 and from port 3 to port 4. When coil S2 is energized the spool shifts and allows flow from port 4 to port 1 and from port 3 to port 2.

Operation of Manual Override Option: To override, twist knurled screw and push or pull to shift spool.

Detented version - twist again after pushing/pulling to hold position.

Features

- Push/pull type manual override button, detented manual override option.

Specifications

Operating Pressure	5000 psi (350 bar)
Nominal Flow	6 gpm at 3000 psi (23 l/min at 210 bar) <i>Consult factory for flow rating above 3000 psi (210 bar)</i>
Internal Leakage	10 cu in/min. at 3000 psi and 158 SUS (160 cc/min at 210 bar and 34 cSt)
Fluid Operating Temp. Range	-4° to 248°F (-20° to 120°C) <i>(Consult factory for usage at temp. outside range.)</i>
Ambient Temperature Range	-4° to 140°F (-20° to 60°C)
Coil Duty Rating	Continuous from 85% to 115% of nominal voltage
Current Draw at 68°F (20°C)	1.5 A at 12VDC; 0.8 A at 24VDC
Minimum Pull-in Current	90% of nominal @ 5000 psi (350 bar)
Fluid Compatibility	Mineral-based or synthetics with lubricating properties
Viscosity	50 to 2000 SUS (7.4 to 420 cSt)
Filtration	21/19/16 or cleaner (per ISO 4406). Use with filter rated $\beta_{10} \geq 200$.
Installation	No orientation restrictions
Cavity	FC10-4 (see <i>Line Bodies & Cavities</i> section)
Cavity Tools	Rougher: 02580248 Finisher: 02580249
Cartridge Weight	0.64 lbs (0.29 kg)
Coil Weight	0.42 lbs (0.19 kg) - 2 coils required
Cartridge Material	Steel with hardened work surfaces. Zinc-plated exposed surfaces. Buna N or Viton® o-rings. PTFE back-up rings.
Coil Material	Class N high temperature magnet wire, steel shell, polyamid encapsulation.
Seal Kits	Buna-N FS104-N P/N: 03051912 Viton® FS104-V P/N: 03071275

Performance

Measured at 158 SUS (34 cSt)
Toil = 115° F (46° C)

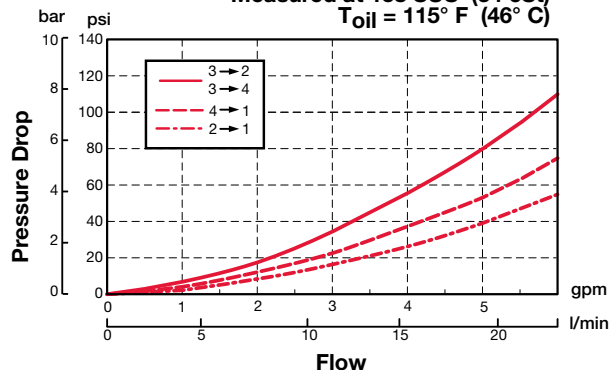

Dimensions

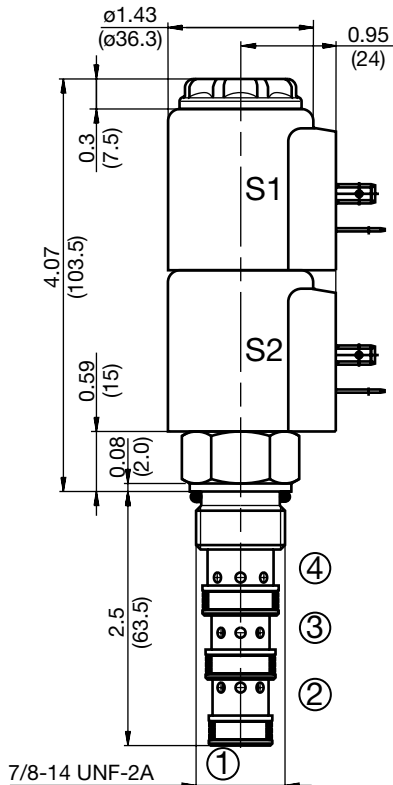
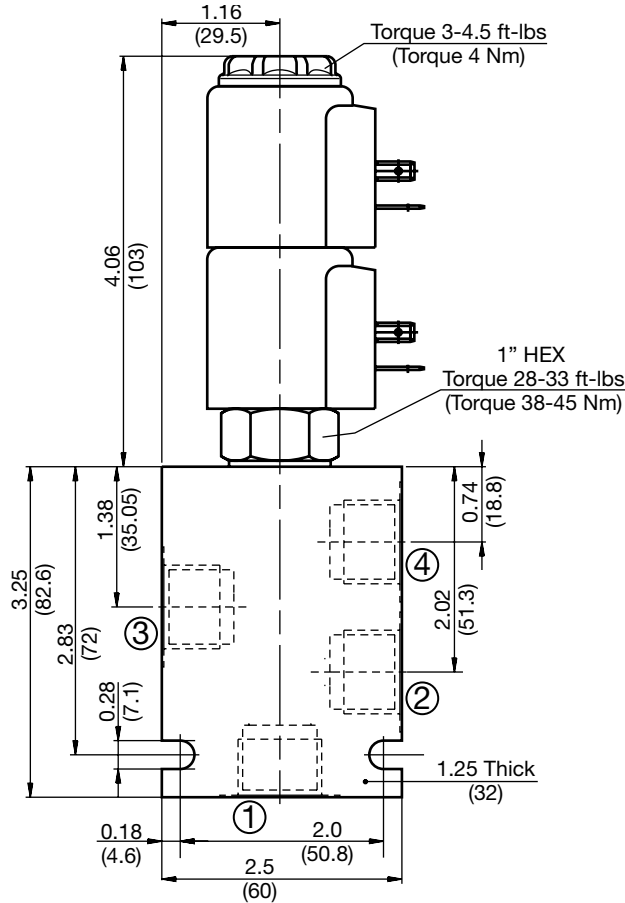

Model Code

WK10E-01-M-C-N-24 DN

Valve Model

Override Option

- (omit) = No manual override
- M = Push/pull type, not detented
- A = Push/pull type, detented

Body & Ports

- C = Cartridge only
- AS8 = SAE-8 ports, aluminum body
- SS8 = SAE-8 ports, steel body

Seals

- N = Buna-N
- V = Viton®

Coil Voltage

- 0 = No coil, cartridge only
- DC 12 = 12 VDC
- 24 = 24 VDC
- 36 = 36 VDC
- 110 = 110 VDC (only available with connector DG)
- AC 24 = 24 VAC
- 115 = 115 VAC
- 230 = 230 VAC

Coil Connector

- DC DG = EN 175301-803-A
- DS = Dual spade (SAEJ858a)*
- DL = Leadwires (2) - 18" long (46 cm)*
- DW = WeatherPak™ on leadwires - 9.5" long (24 cm)*
- DN = Deutsch™ DT04-2P, molded, axial (IP69K Rated)*
- DT = Amp Junior Timer™, molded, radial mount*

AC AG = EN 175301-803-A

Coil Model

40-1836, 2 per assembly

For other coil connector types consult factory

*Coils with internal diode are available, consult factory.

Manual Override Options

Option M - Non Detented

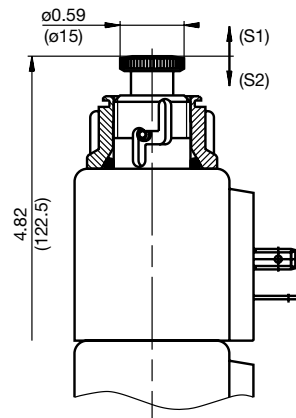

Option A - Detented

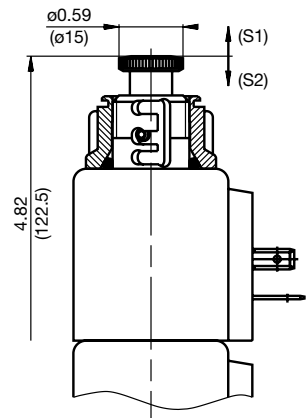

Standard Line Bodies*

Code	Part No	Material	Pressure Rating	Weight
FH104-AS8	03038110	Aluminum, anodized	3500 psi (245 bar)	0.72 lb (0.33 kg)
FH104-SS8	03037868	Steel, zinc plated	6000 psi (420 bar)	2.12 lb (0.96 kg)

*Please refer to Line Bodies & Cavities section for details

All measurements in inches (mm).
Subject to technical modifications

SOLENOID VALVES

WK06G-01

Spool Type, Direct Acting

Up to 2 gpm (7.6 l/min) • 5000 psi (350 bar)

Hydraulic Symbol

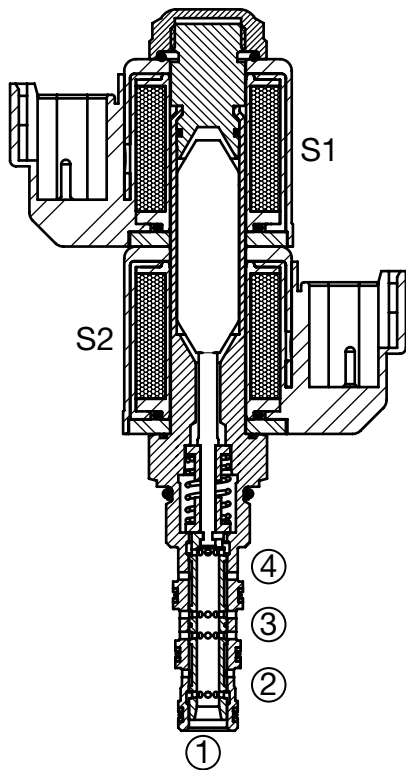
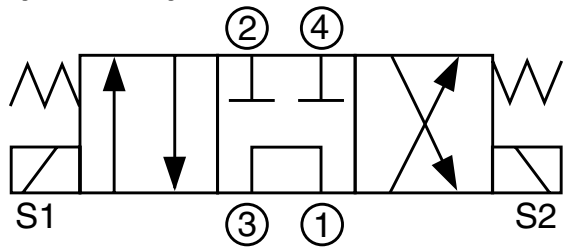

Description

A screw-in cartridge, solenoid operated, 4-way, 3 position, direct acting, spool type valve.

Operation

When de-energized the WK06G allows flow from port 3 to port 1, while blocking flow at ports 2 and 4. When coil S1 is energized the spool shifts and allows flow from port 3 to port 2 and from port 4 to port 1. When coil S2 is energized the spool shifts and allows flow from port 3 to port 4 and from port 2 to port 1.

Specifications

Operating Pressure	5000 psi (350 bar), 3000 psi (210 bar) Max Port 1
Nominal Flow	See Operating Limits
Internal Leakage	11.6 cu in/min. at 3000 psi and 135 SUS (190 cc/min at 207 bar and 28 cSt)
Fluid Operating Temp Range	-20° to 248°F (-29° to 120°C)
Ambient Temperature Range	-20° to 140°F (-29° to 60°C)
Coil Duty Rating	Continuous from 85% to 115% of nominal voltage
Current Draw at 68°F (20°C)	984 mA at 12VDC; 492 mA at 24VDC
Min. Pull-in Current to Operate Valve	70% of nominal amperage
Fluid Compatibility	Mineral-Based or Synthetics with lubricating properties
Viscosity	50 to 2000 SUS (7.4 to 420 cSt)
Filtration	21/19/16 or cleaner per (ISO 4406)
Installation	No orientation restrictions
Cavity	FC06-4 (see <i>Line Bodies & Cavities</i> section)
Cavity Tools	Rougher: 02582057 Finisher: 02582058
Cartridge Weight	3.6 oz (102 grams)
Coil Weight	3.1 oz (88 grams) each (2 required)
Cartridge Material	Steel with hardened work surfaces. Zinc plated exposed surfaces. Buna N or Viton® o-rings. Solid thermoplastic polyester back-up rings.
Coil Material	Class N, 200°C high temperature magnet wire, steel shell, polyester encapsulation.
Seal Kits	Buna-N P/N: 02610188 Viton® P/N: 02610189

Performance

Measured at 135 SUS (28 cSt)
T_{oil} = 100°F (38°C)

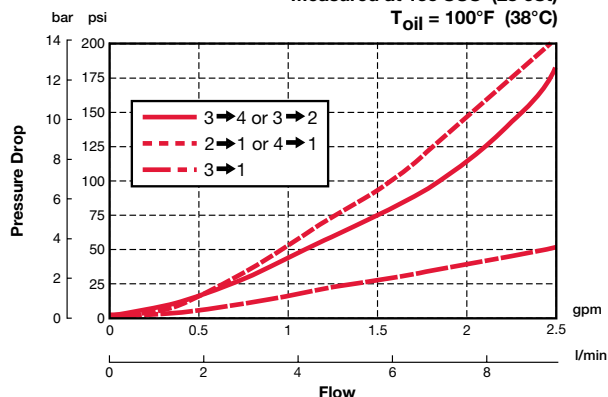

Dimensions

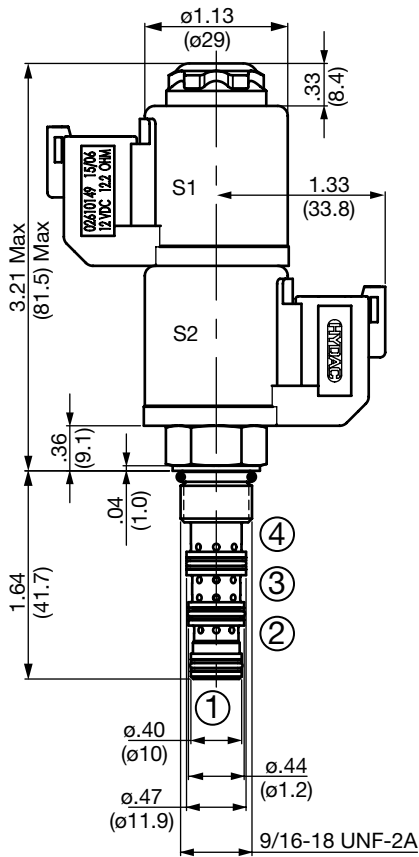
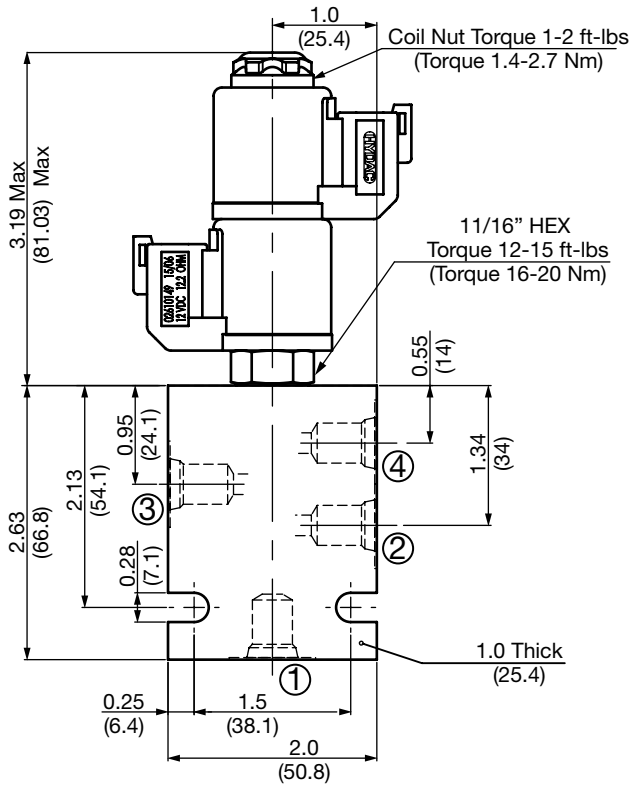

All measurements in inches (mm).
Subject to technical modifications

Model Code

WK06G-01 M-C-N-24 DN

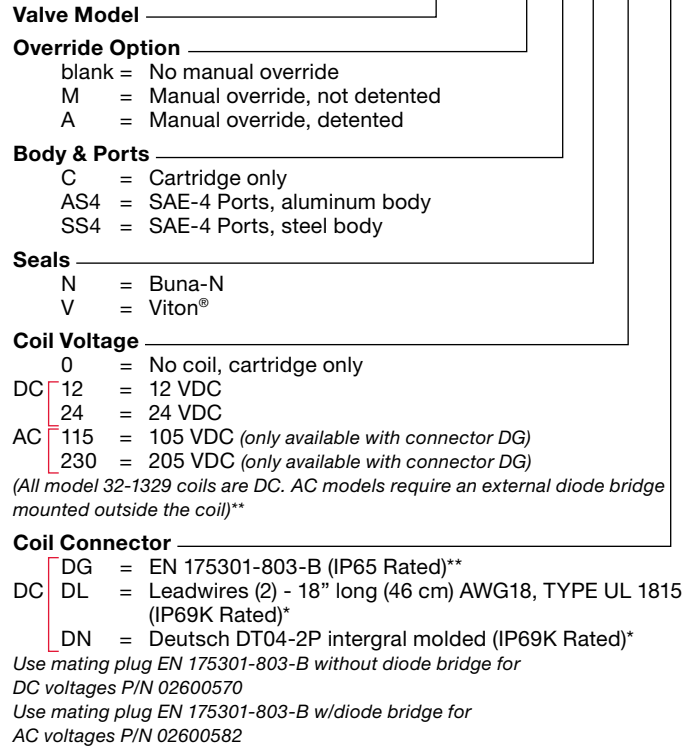

Coil Model 32-1329

For other coil connector types consult factory

** Mating Plugs sold separately

*Coils with internal transient suppression diode are available, consult factory.

Operating Limits

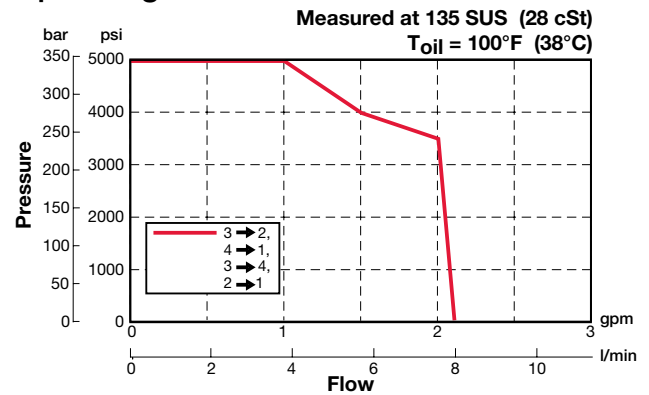

Standard Line Bodies*

Code	Part No	Material	Pressure Rating	Weight
FH064-AS4	02600462	Aluminum, anodized	3500 psi (245 bar)	0.41 lbs (0.19 kg)
FH064-SS4	02600461	Steel, zinc plated	6000 psi (420 bar)	1.22 lbs (0.55 kg)

*Please refer to Line Bodies & Cavities section for details

SOLENOID VALVES

WK10G-01

Spool Type, Direct Acting

Up to 6 gpm (23 l/min) • 5000 psi (350 bar)

Hydraulic Symbol

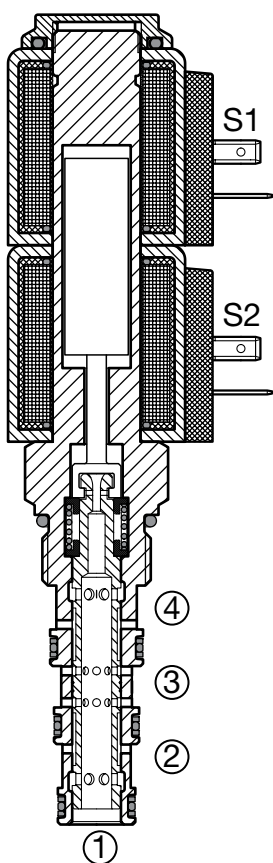
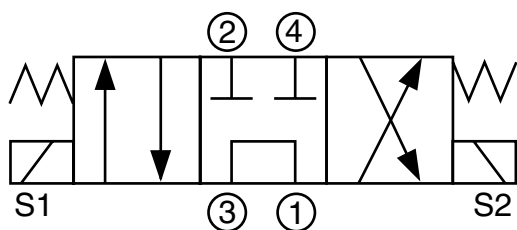

Description

A screw-in cartridge, solenoid operated, 4-way, 3 position, direct acting, spool type valve.

Operation

When de-energized the WK10G allows flow from port 3 to port 1, while blocking flow at ports 2 and 4. When coil S1 is energized the spool shifts and allows flow from port 3 to port 2 and from port 4 to port 1. When coil S2 is energized the spool shifts and allows flow from port 3 to port 4 and from port 2 to port 1.

Operation of Manual Override Option: To override, twist knurled screw and push or pull to shift spool.

Detented version - twist again after pushing/pulling to hold position.

Features

- Push/pull type manual override button, detented manual override option.

Specifications

Operating Pressure	5000 psi (350 bar)
Nominal Flow	6 gpm at 3000 psi (23 l/min at 210 bar) <i>Consult factory for flow rating above 3000 psi (210 bar)</i>
Internal Leakage	10 cu in/min. at 3000 psi and 158 SUS (160 cc/min at 210 bar and 34 cSt)
Fluid Operating Temp. Range	-4° to 248°F (-20° to 120°C) <i>(Consult factory for usage at temp. outside range.)</i>
Ambient Temperature Range	-4° to 140°F (-20° to 60°C)
Coil Duty Rating	Continuous from 85% to 115% of nominal voltage
Current Draw at 68°F (20°C)	1.5 A at 12VDC; 0.8 A at 24VDC
Minimum Pull-in Current	90% of nominal @ 5000 psi (350 bar)
Fluid Compatibility	Mineral-based or synthetics with lubricating properties
Viscosity	50 to 2000 SUS (7.4 to 420 cSt)
Filtration	21/19/16 or cleaner (per ISO 4406). Use with filter rated $\beta_{10} \geq 200$.
Installation	No orientation restrictions
Cavity	FC10-4 (see <i>Line Bodies & Cavities</i> section)
Cavity Tools	Rougher: 02580248 Finisher: 02580249
Cartridge Weight	0.64 lbs (0.29 kg)
Coil Weight	0.42 lbs (0.19 kg) - 2 coils required
Cartridge Material	Steel with hardened work surfaces. Zinc-plated exposed surfaces. Buna N or Viton® o-rings. PTFE back-up rings.
Coil Material	Class N high temperature magnet wire, steel shell, polyamide encapsulation.
Seal Kits	Buna-N FS104-N P/N: 03051912 Viton® FS104-V P/N: 03071275

Performance

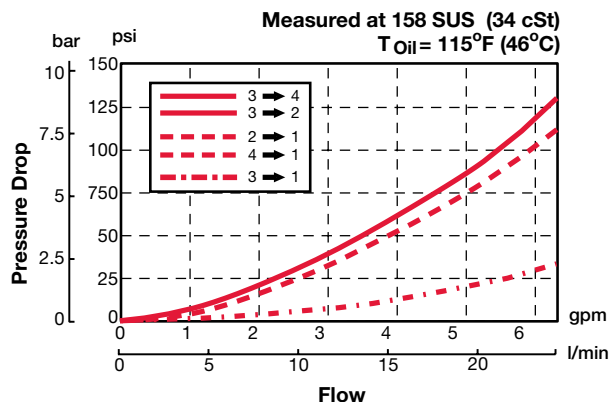

Dimensions

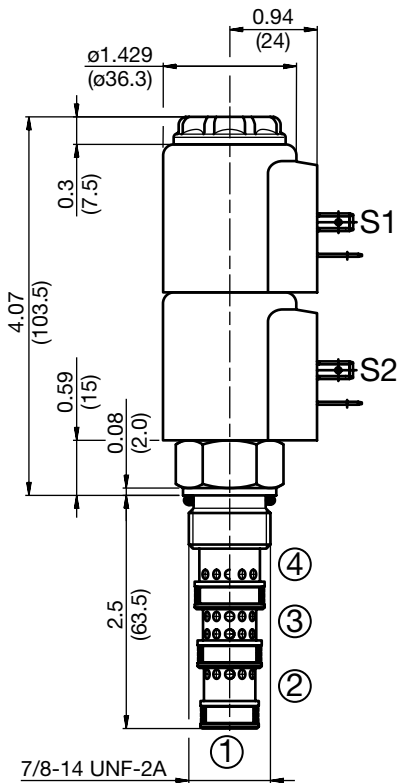
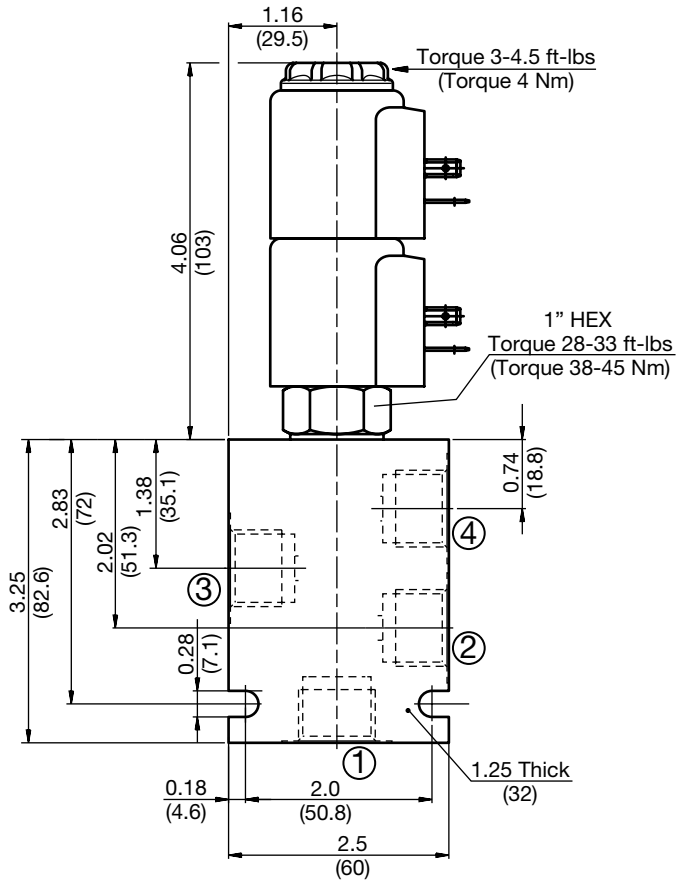

Model Code

WK10G-01-M-C-N-24 DN

Valve Model

Override Option

- (omit) = No manual override
- M = Push/pull type, not detented
- A = Push/pull type, detented

Body & Ports

- C = Cartridge only
- AS8 = SAE-8 ports, aluminum body
- SS8 = SAE-8 ports, steel body

Seals

- N = Buna-N
- V = Viton®

Coil Voltage

- 0 = No coil, cartridge only
- DC 12 = 12 VDC
- 24 = 24 VDC
- 36 = 36 VDC
- 110 = 110 VDC (only available with connector DG)
- AC 24 = 24 VAC
- 115 = 115 VAC
- 230 = 230 VAC

Coil Connector

- DC DG = EN 175301-803-A
- DS = Dual spade (SAEJ858a)*
- DL = Leadwires (2) - 18" long (46 cm)*
- DW = WeatherPak™ on leadwires - 9.5" long (24 cm)*
- DN = Deutsch™ DT04-2P, molded, axial (IP69K Rated)*
- DT = Amp Junior Timer™, molded, radial mount*

AC AG = EN 175301-803-A

Coil Model

40-1836, 2 per assembly

For other coil connector types consult factory

*Coils with internal diode are available, consult factory.

Manual Override Options

Option M - Non Detented

Option A - Detented

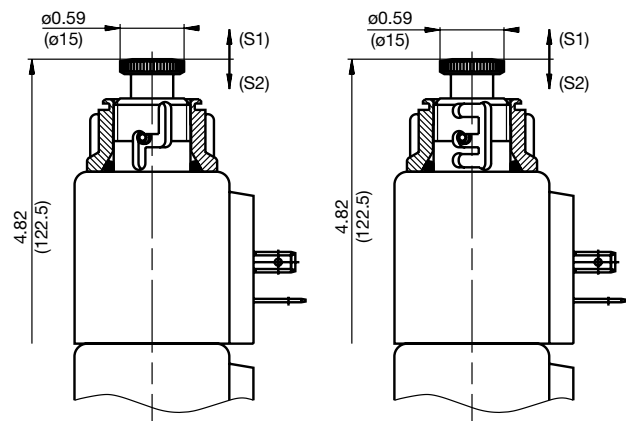

Standard Line Bodies*

Code	Part No	Material	Pressure Rating	Weight
FH104-AS8	03038110	Aluminum, anodized	3500 psi (245 bar)	0.72 lb (0.33 kg)
FH104-SS8	03037868	Steel, zinc plated	6000 psi (420 bar)	2.12 lb (0.96 kg)

*Please refer to Line Bodies & Cavities section for details

All measurements in inches (mm).
Subject to technical modifications

SOLENOID VALVES

WK06H-01

Spool Type, Direct Acting

Up to 2.4 gpm (9 l/min) • 5000 psi (350 bar)

Hydraulic Symbol

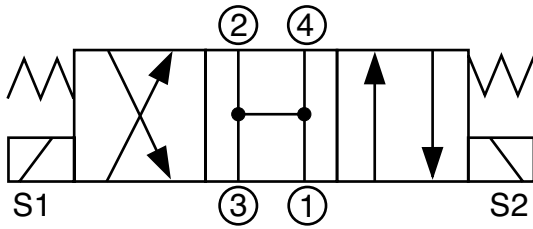

Description

A screw-in cartridge, solenoid operated, 4-way, 3 position, direct acting, spool type valve.

Operation

When de-energized the WK06H allows flow to all ports. When coil S1 is energized the spool shifts and allows flow from port 2 to port 1 and from port 3 to port 4. When coil S2 is energized the spool shifts and allows flow from port 4 to port 1 and from port 3 to port 2.

Specifications

Operating Pressure	5000 psi (350 bar), 3000 psi (210 bar) Max Port 1
Nominal Flow	See Operating Limits
Internal Leakage	6.0 cu in/min. at 3000 psi and 135 SUS (100 cc/min at 207 bar and 28 cSt)
Fluid Operating Temp Range	-20° to 248°F (-29° to 120°C)
Ambient Temperature Range	-20° to 140°F (-29° to 60°C)
Coil Duty Rating	Continuous from 85% to 115% of nominal voltage
Current Draw at 68°F (20°C)	984 mA at 12VDC; 492 mA at 24VDC
Min. Pull-in Current to Operate Valve	70% of nominal amperage
Fluid Compatibility	Mineral-Based or Synthetics with lubricating properties
Viscosity	50 to 2000 SUS (7.4 to 420 cSt)
Filtration	21/19/16 or cleaner per (ISO 4406)
Installation	No orientation restrictions
Cavity	FC06-4 (see <i>Line Bodies & Cavities</i> section)
Cavity Tools	Rougher: 02582057 Finisher: 02582058
Cartridge Weight	3.6 oz (102 grams)
Coil Weight	3.1 oz (88 grams) each (2 required)
Cartridge Material	Steel with hardened work surfaces. Zinc plated exposed surfaces. Buna N or Viton® o-rings. Solid thermoplastic polyester back-up rings.
Coil Material	Class N, 200°C high temperature magnet wire, steel shell, polyester encapsulation.
Seal Kits	Buna-N FS064-N P/N: 02610188 Viton® FS064-V P/N: 02610189

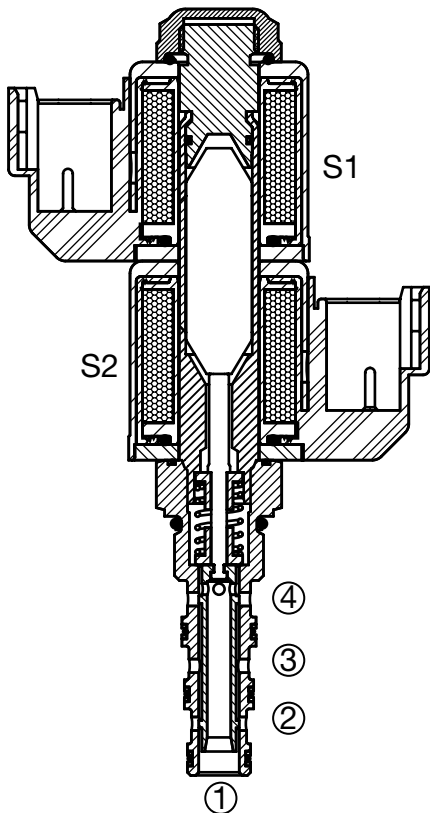

Performance

Measured at 135 SUS (28 cSt)
T_{oil} = 100° F (38°C)

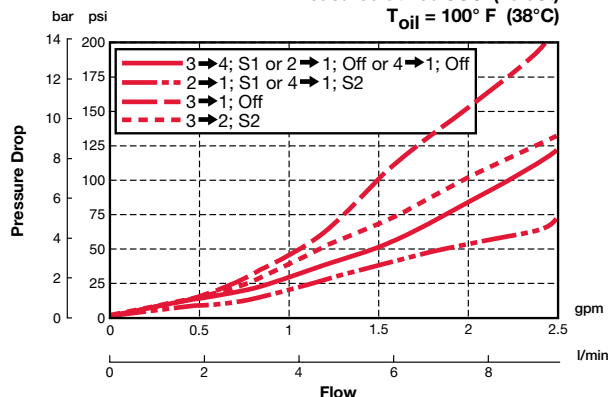

Dimensions

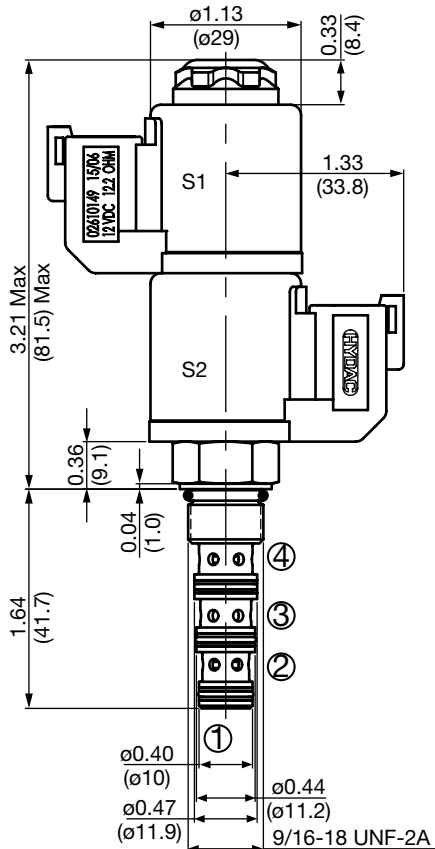
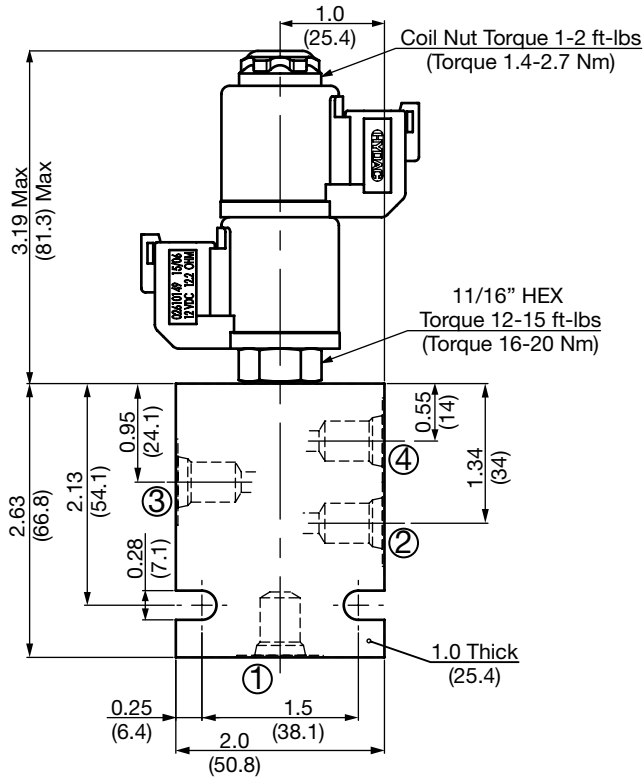

All measurements in inches (mm).
Subject to technical modifications

Model Code

WK06H-01 M-C-N-24 DN

Valve Model

Override Option

- blank = No manual override
- M = Manual override, not detented
- A = Manual override, detented

Body & Ports

- C = Cartridge only
- AS4 = SAE-4 Ports, aluminum body
- SS4 = SAE-4 Ports, steel body

Seals

- N = Buna-N
- V = Viton®

Coil Voltage

- 0 = No coil, cartridge only
- DC 12 = 12 VDC
- DC 24 = 24 VDC
- AC 115 = 105 VDC (only available with connector DG)
- AC 230 = 205 VDC (only available with connector DG)

(All model 32-1329 coils are DC. AC models require an external diode bridge mounted outside the coil)**

Coil Connector

- DG = EN 175301-803-B (IP65 Rated)**
- DC DL = Leadwires (2) - 18" long (46 cm) AWG18, TYPE UL 1815 (IP69K Rated)*
- DN = Deutsch DT04-2P intergral molded (IP69K Rated)*

Use mating plug EN 175301-803-B without diode bridge for DC voltages P/N 02600570

Use mating plug EN 175301-803-B w/diode bridge for AC voltages P/N 02600582

Coil Model 32-1329

For other coil connector types consult factory

** Mating Plugs sold separately

*Coils with internal transient suppression diode are available, consult factory.

Operating Limits

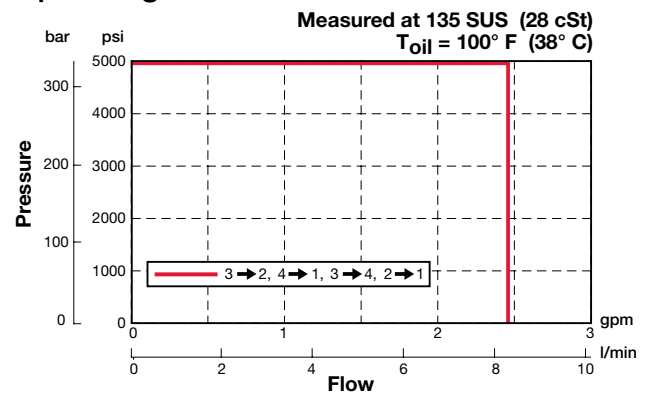

Standard Line Bodies*

Code	Part No	Material	Pressure Rating	Weight
FH064-AS4	02600462	Aluminum, anodized	3500 psi (245 bar)	0.41 lbs (0.19 kg)
FH064-SS4	02600461	Steel, zinc plated	6000 psi (420 bar)	1.22 lbs (0.55 kg)

*Please refer to Line Bodies & Cavities section for details

SOLENOID VALVES

WK10H-01

Spool Type, Direct Acting

Up to 6 gpm (23 l/min) • 5000 psi (350 bar)

Hydraulic Symbol

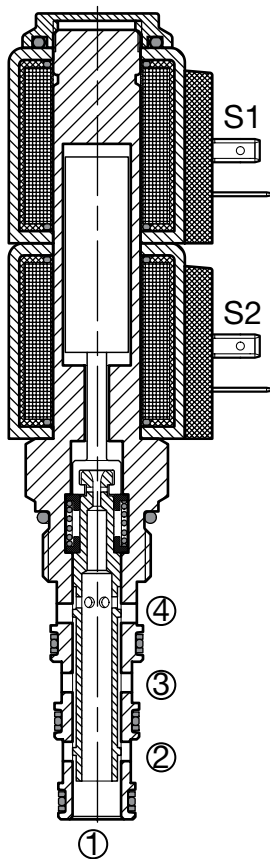
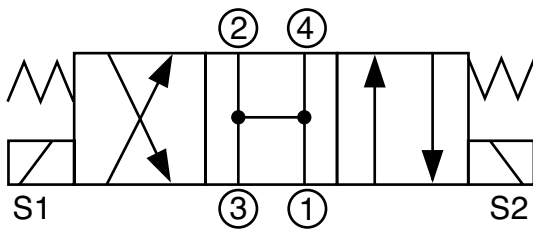

Description

A screw-in cartridge, solenoid operated, 4-way, 3 position, direct acting, spool type valve.

Operation

When de-energized the WK10H allows flow to all ports. When coil S1 is energized the spool shifts and allows flow from port 1 to port 2 and from port 3 to port 4. When coil S2 is energized the spool shifts and allows flow from port 4 to port 1 and from port 3 to port 2.

Operation of Manual Override Option: To override, twist knurled screw and push or pull to shift spool.

Detented version - twist again after pushing/pulling to hold position.

Features

- Push/pull type manual override button, detented manual override option.

Specifications

Operating Pressure	5000 psi (350 bar)
Nominal Flow	6 gpm at 3000 psi (23 l/min at 210 bar) <i>Consult factory for flow rating above 3000 psi (210 bar)</i>
Internal Leakage	10 cu in/min. at 3000 psi and 158 SUS (160 cc/min at 210 bar and 34 cSt)
Fluid Operating Temp. Range	-4° to 248°F (-20° to 120°C) <i>(Consult factory for usage at temp. outside range.)</i>
Ambient Temperature Range	-4° to 140°F (-20° to 60°C)
Coil Duty Rating	Continuous from 85% to 115% of nominal voltage
Current Draw at 68°F (20°C)	1.5 A at 12VDC; 0.8 A at 24VDC
Minimum Pull-in Current	85% of nominal @ 5000 psi (350 bar)
Fluid Compatibility	Mineral-based or synthetics with lubricating properties
Viscosity	50 to 2000 SUS (7.4 to 420 cSt)
Filtration	21/19/16 or cleaner (per ISO 4406). Use with filter rated $\beta_{10} \geq 200$.
Installation	No orientation restrictions
Cavity	FC10-4 (see <i>Line Bodies & Cavities</i> section)
Cavity Tools	Rougher: 02580248 Finisher: 02580249
Cartridge Weight	0.64 lbs (0.29 kg)
Coil Weight	0.42 lbs (0.19 kg) - 2 coils required
Cartridge Material	Steel with hardened work surfaces. Zinc-plated exposed surfaces. Buna N or Viton® o-rings. PTFE back-up rings.
Coil Material	Class N high temperature magnet wire, steel shell, polyamid encapsulation.
Seal Kits	Buna-N FS104-N P/N: 03051912 Viton® FS104-V P/N: 03071275

Performance

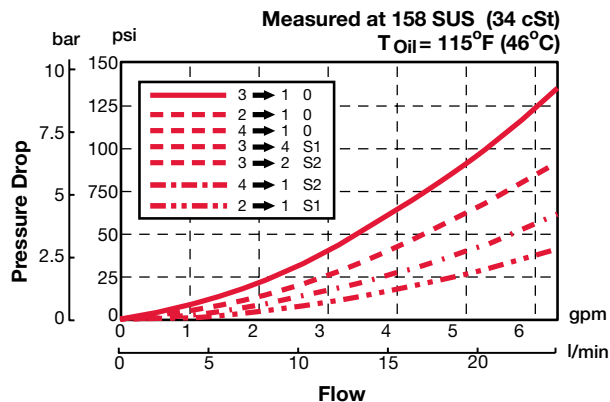

Dimensions

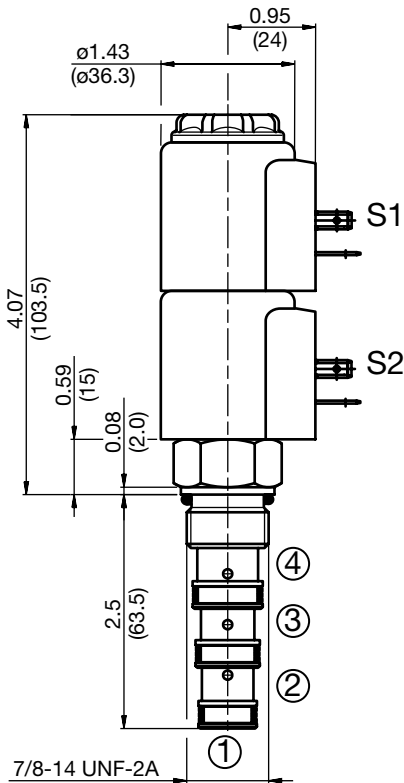
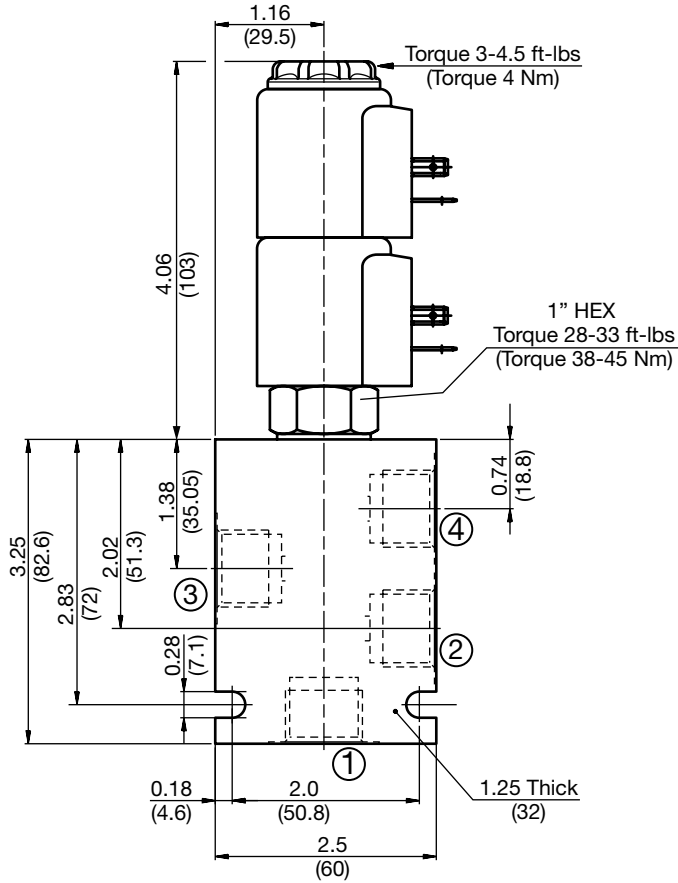

Model Code

WK10H-01-M-C-N-24 DN

Valve Model

Override Option

- (omit) = No manual override
- M = Push/pull type, not detented
- A = Push/pull type, detented

Body & Ports

- C = Cartridge only
- AS8 = SAE-8 ports, aluminum body
- SS8 = SAE-8 ports, steel body

Seals

- N = Buna-N
- V = Viton®

Coil Voltage

- 0 = No coil, cartridge only
- DC 12 = 12 VDC
- 24 = 24 VDC
- 36 = 36 VDC
- 110 = 110 VDC (only available with connector DG)
- AC 24 = 24 VAC
- 115 = 115 VAC
- 230 = 230 VAC

Coil Connector

- DC DG = EN 175301-803-A
- DS = Dual spade (SAEJ858a)*
- DL = Leadwires (2) - 18" long (46 cm)*
- DW = WeatherPak™ on leadwires - 9.5" long (24 cm)*
- DN = Deutsch™ DT04-2P, molded, axial (IP69K Rated)*
- DT = Amp Junior Timer™, molded, radial mount*

AC AG = EN 175301-803-A

Coil Model 40-1836, 2 per assembly

For other coil connector types consult factory

*Coils with internal diode are available, consult factory.

Manual Override Options

Option M - Non Detented

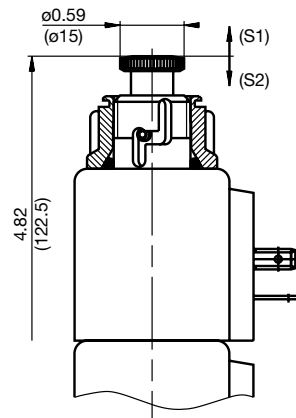

Option A - Detented

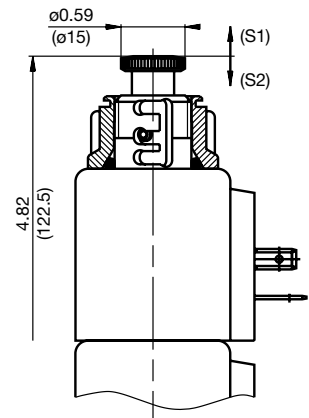

Standard Line Bodies*

Code	Part No	Material	Pressure Rating	Weight
FH104-AS8	03038110	Aluminum, anodized	3500 psi (245 bar)	0.72 lb (0.33 kg)
FH104-SS8	03037868	Steel, zinc plated	6000 psi (420 bar)	2.12 lb (0.96 kg)

*Please refer to Line Bodies & Cavities section for details

All measurements in inches (mm).
Subject to technical modifications

SOLENOID VALVES

WK06J-01

Spool Type, Direct Acting

Up to 3 gpm (11.4 l/min) • 5000 psi (350 bar)

Hydraulic Symbol

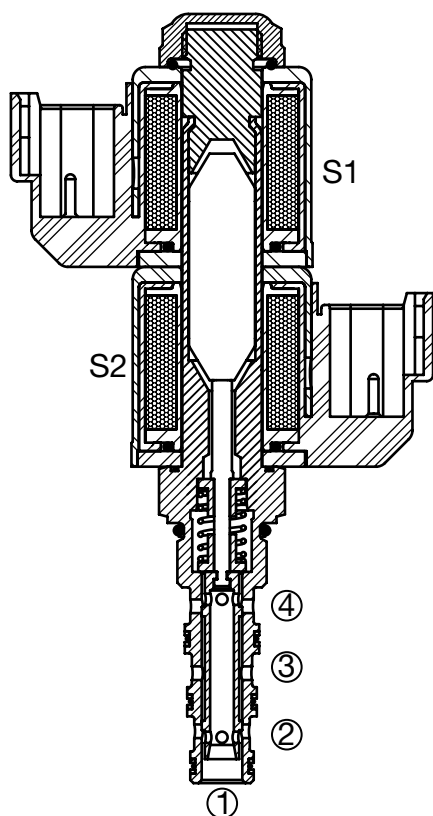
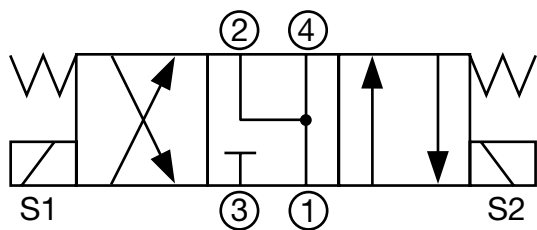

Description

A screw-in cartridge, solenoid operated, 4-way, 3 position, direct acting, spool type valve.

Operation

When de-energized the WK06J allows flow from cylinder ports 2 and 4 to port 1, port 3 is blocked. When coil S1 is energized the spool shifts and allows flow from port 2 to port 1 and from port 3 to port 4. When coil S2 is energized the spool shifts and allows flow from port 4 to port 1 and from port 3 to port 2.

Specifications

Operating Pressure	5000 psi (350 bar), 3000 psi (210 bar) Max Port 1		
Nominal Flow	See Operating Limits		
Internal Leakage	11.6 cu in/min. at 3000 psi and 158 SUS (190 cc/min at 250 bar and 34 cSt)		
Fluid Operating Temp. Range	-20° to 248°F (-29° to 120° C)		
Ambient Temperature Range	-20° to +140°F (-29° to +60°C)		
Coil Duty Rating	Continuous from 85% to 115% of nominal voltage		
Current Draw at 68°F (20°C)	984 mA at 12VDC; 492 mA at 24VDC		
Min. Pull-in Current to Operate Valve	70% of nominal amperage		
Fluid Compatibility	Mineral-Based or Synthetics with lubricating properties		
Viscosity	50 to 2000 SUS (7.4 to 420 cSt)		
Filtration	21/19/16 or cleaner per (ISO 4406)		
Installation	No orientation restrictions		
Cavity	FC06-4 (see <i>Line Bodies & Cavities</i> section)		
Cavity Tools	Rougher: 02582057 Finisher: 02582058		
Cartridge Weight	3.6 oz (102 grams)		
Coil Weight	3.1 oz (88 grams) each (2 required)		
Cartridge Material	Steel with hardened work surfaces. Zinc plated exposed surfaces. Buna N or Viton® o-rings. Solid thermoplastic polyester back-up rings.		
Coil Material	Class N, 200°C high temperature magnet wire, steel shell, polyester encapsulation.		
Seal Kits	Buna-N	FS064-N	P/N: 02610188
	Viton®	FS064-V	P/N: 02610189

Performance

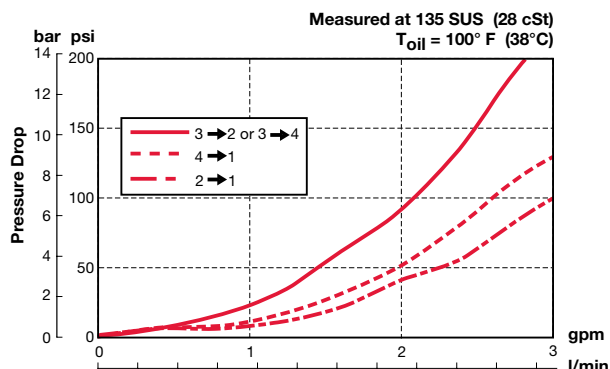

Dimensions

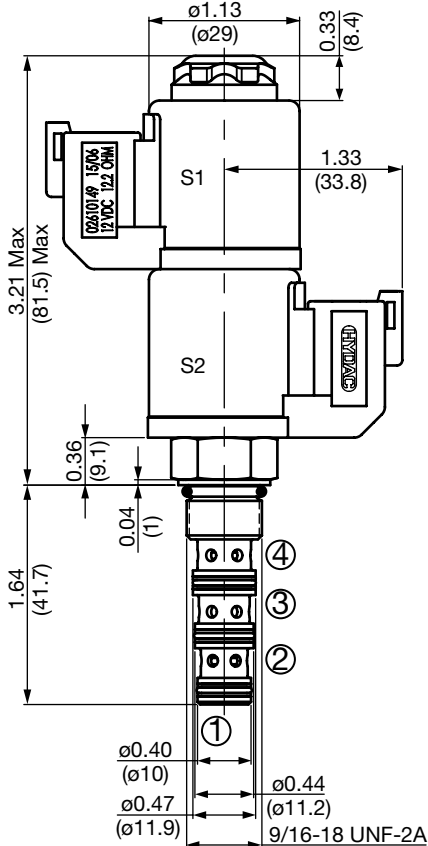
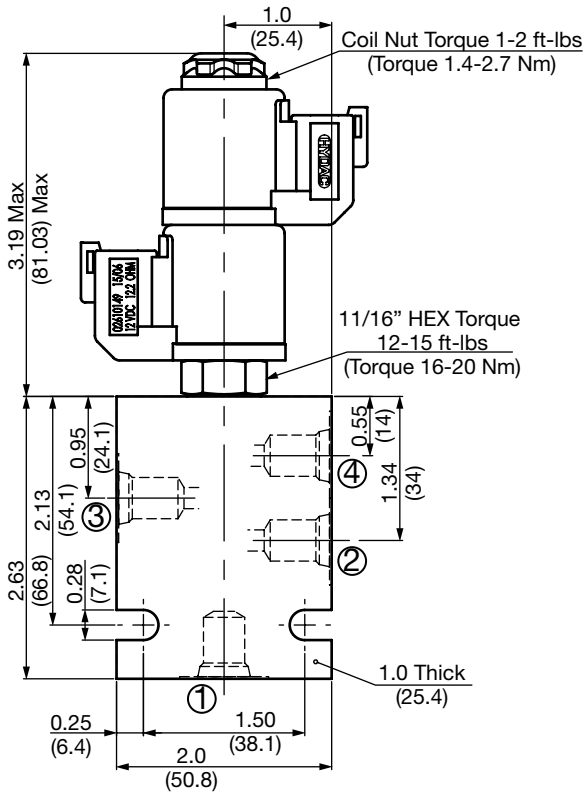

All measurements in inches (mm).
Subject to technical modifications

PN#02087369 / 10.19 / CHD1110-1389

Model Code

WK06J-01 M-C-N-24 DN

Valve Model

Override Option

- blank = No manual override
- M = Manual override, not detented
- A = Manual override, detented

Body & Ports

- C = Cartridge only
- AS4 = SAE-4 Ports, aluminum body
- SS4 = SAE-4 Ports, steel body

Seals

- N = Buna-N
- V = Viton®

Coil Voltage

- 0 = No coil, cartridge only
- DC 12 = 12 VDC
- 24 = 24 VDC
- AC 115 = 105 VDC (only available with connector DG)
- 230 = 205 VDC (only available with connector DG)

(All model 32-1329 coils are DC. AC models require an external diode bridge mounted outside the coil)**

Coil Connector

- DG = EN 175301-803-B (IP65 Rated)**
- DC DL = Leadwires (2) - 18" long (46 cm) AWG18, TYPE UL 1815 (IP69K Rated)*
- DN = Deutsch DT04-2P intergral molded (IP69K Rated)*

Use mating plug EN 175301-803-B without diode bridge for DC voltages P/N 02600570

Use mating plug EN 175301-803-B w/diode bridge for AC voltages P/N 02600582

Coil Model 32-1329

For other coil connector types consult factory

** Mating Plugs sold separately

*Coils with internal transient suppression diode are available, consult factory.

Operating Limits

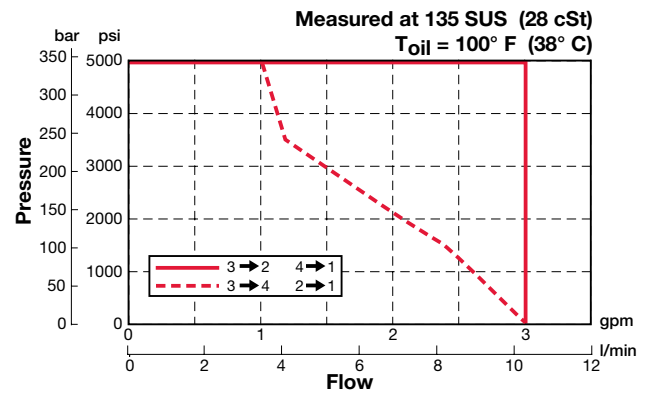

Standard Line Bodies*

Code	Part No	Material	Pressure Rating	Weight
FH064-AS4	02600462	Aluminum, anodized	3500 psi (245 bar)	0.41 lbs (0.19 kg)
FH064-SS4	02600461	Steel, zinc plated	6000 psi (420 bar)	1.22 lbs (0.55 kg)

*Please refer to Line Bodies & Cavities section for details

SOLENOID VALVES

WK08J-01

Spool Type, Direct Acting

Up to 5 gpm (19 l/min) • 5000 psi (350 bar)

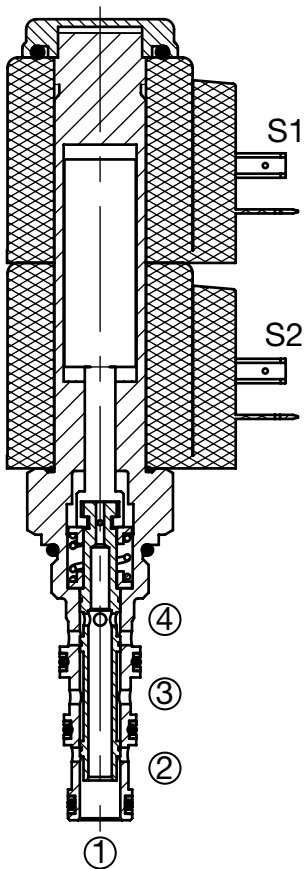

Hydraulic Symbol

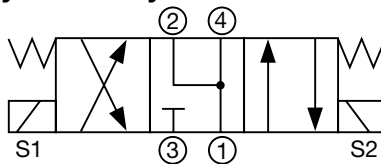

Description

A screw-in cartridge, solenoid operated, 4-way, 3 position, direct acting, spool type valve.

Operation

When de-energized the WK08J allows flow from cylinder ports 2 and 4 to port 1, port 3 is blocked. When coil S1 is energized the spool shifts and allows flow from port 2 to port 1 and from port 3 to port 4. When coil S2 is energized the spool shifts and allows flow from port 4 to port 1 and from port 3 to port 2.

Operation of Manual Override Option: To override, twist knurled screw and push or pull to shift spool.

Detented version - twist again after pushing/pulling to hold position.

Features

- Push/pull type manual override button, detented manual override option.
- High flow capacity

Specifications

Operating Pressure	5000 psi (350 bar)
Nominal Flow	5 gpm at 3000 psi (20 l/min@ 210 bar)
Internal Leakage	10 cu in/min. at 3000 psi and 158 SUS (160 cc/min at 210 bar and 34 cSt)
Fluid Operating Temp Range	-20° to 248°F (-29° to 120°C)
Ambient Temperature Range	-20° to 140°F (-29° to 60°C)
Coil Duty Rating	Continuous from 85% to 115% of nominal voltage
Current Draw at 68°F (20°C)	1.5 A at 12VDC; 0.8 A at 24VDC
Minimum Pull-in Current	75% of nominal amperage
Typical Response Time (Varies with Pressure and Flow)	On: 30 to 60 ms Off: 20 to 40 ms
Fluid Compatibility	Mineral-Based or Synthetics with lubricating properties
Viscosity	50 to 2000 SUS (7.4 to 420 cSt)
Filtration	21/19/16 or cleaner per (ISO 4406)
Installation	No orientation restrictions
Cavity	FC08-4 (see Line Bodies & Cavities section)
Cavity Tools	Rougher: 02580088 Finisher: 02580089
Cartridge Weight	0.6 lbs (0.27 kg)
Coil Weight	2 x 0.42 lbs (2 x 0.19 kg)
Cartridge Material	Steel with hardened work surfaces. Zinc plated solenoid tube surface. Buna N or Viton® o-rings. Solid thermoplastic polyester back-up rings.
Coil Material	Class N high temperature magnet wire, steel shell, polyamid encapsulation.
Seal Kits	Buna-N FS084-N P/N: 03071272 Viton® FS084-V P/N: 03071273

Performance

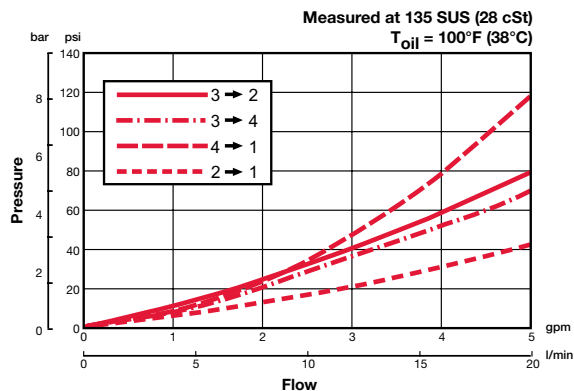

Operating Limits

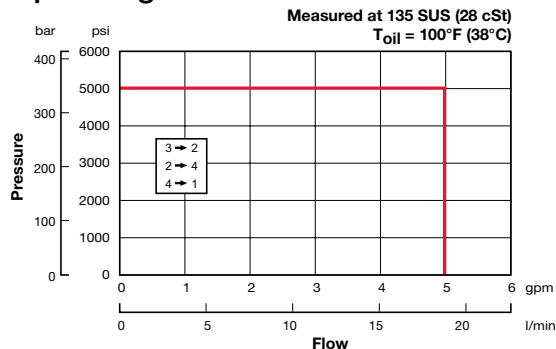

Dimensions

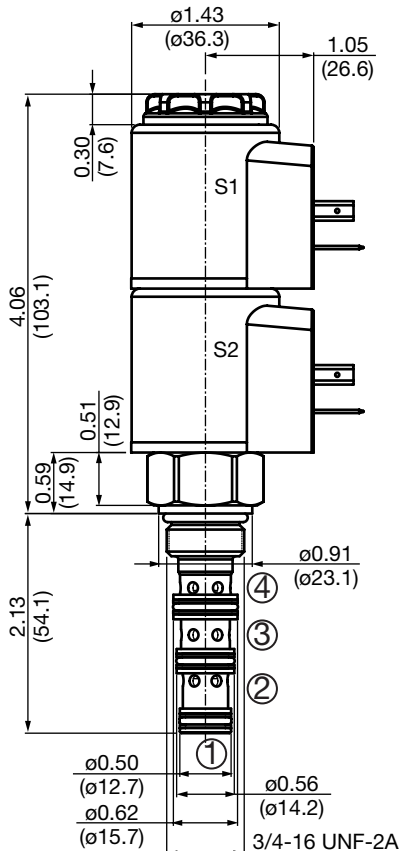
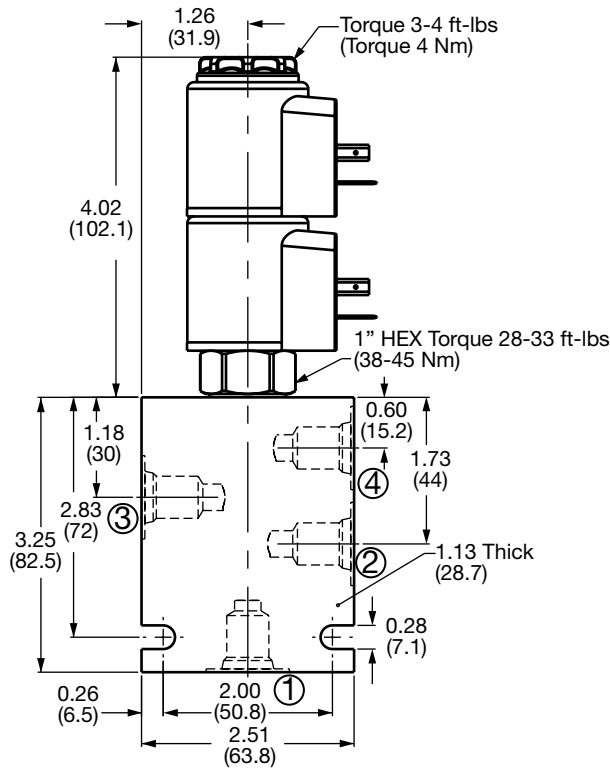

All measurements in inches (mm).
Subject to technical modifications

Model Code

WK08J-01-M-C-N-24 DN

Valve Model

Override Option

- (omit) = No manual override
- M = Push/pull type, not detented
- A = Push/pull type, detented

Body & Ports

- C = Cartridge only
- AS6 = SAE-6 ports, aluminum body
- SS6 = SAE-6 ports, steel body

Seals

- N = Buna-N
- V = Viton®

Coil Voltage

- 0 = No coil, cartridge only
- DC 12 = 12 VDC
- 24 = 24 VDC
- 36 = 36 VDC
- 110 = 110 VDC (only available with connector DG)
- AC 24 = 24 VAC
- 115 = 115 VAC
- 230 = 230 VAC

Coil Connector

- DC DG = EN 175301-803-A
- DS = Dual spade (SAEJ858a)*
- DL = Leadwires (2) - 18" long (46 cm)*
- DW = WeatherPak™ on leadwires - 9.5" long (24 cm)*
- DN = Deutsch™ DT04-2P, molded, axial (IP69K Rated)*
- DT = Amp Junior Timer™, molded, radial mount*

AC AG = EN 175301-803-A

Coil Model 40-1836, 2 per assembly

For other coil connector types consult factory

*Coils with internal diode are available, consult factory

Manual Override Options

Option M - Non Detented

Option A - Detented

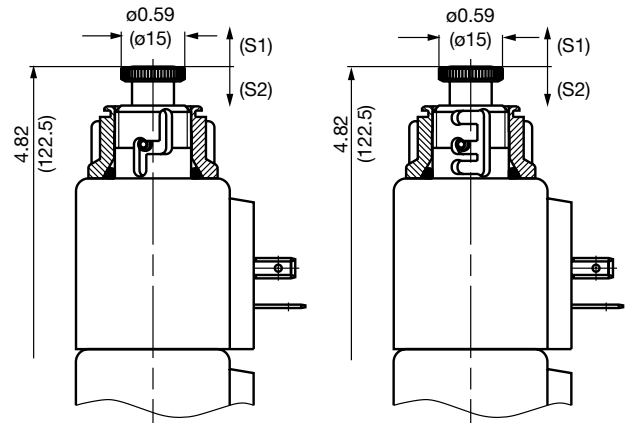

Standard Line Bodies*

Code	Part No	Material	Pressure Rating	Weight
FH084-AS6	03011404	Aluminum, anodized	3500 psi (245 bar)	0.72 lb (0.33 kg)
FH084-SS6	00563381	Steel, zinc plated	6000 psi (420 bar)	2.12 lb (0.96 kg)

*Please refer to Line Bodies & Cavities section for details

SOLENOID VALVES

WK10J-01

Spool Type, Direct Acting

Up to 6 gpm (23 l/min) • 5000 psi (350 bar)

Hydraulic Symbol

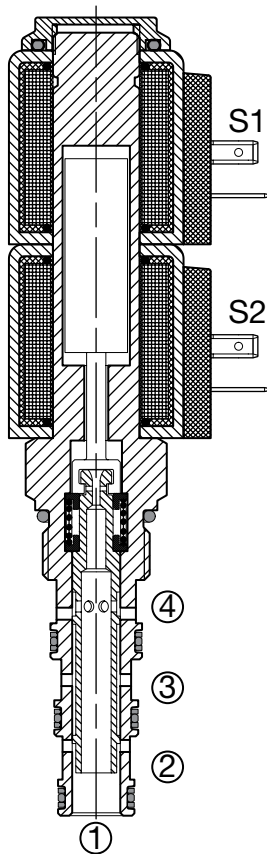
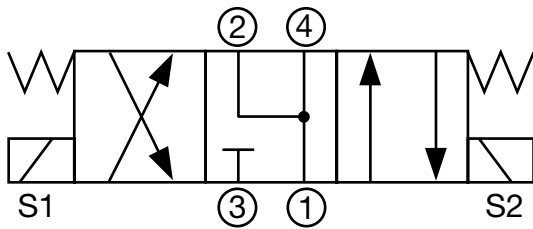

Description

A screw-in cartridge, solenoid operated, 4-way, 3 position, direct acting, spool type valve.

Operation

When de-energized the WK10J allows flow from cylinder ports 2 and 4 to port 1, port 3 is blocked. When coil S1 is energized the spool shifts and allows flow from port 1 to port 2 and from port 3 to port 4. When coil S2 is energized the spool shifts and allows flow from port 4 to port 1 and from port 3 to port 2.

Operation of Manual Override Option: To override, twist knurled screw and push or pull to shift spool.

Detented version - twist again after pushing/pulling to hold position.

Features

- Push/pull type manual override button, detented manual override option.

Specifications

Operating Pressure	5000 psi (350 bar)
Nominal Flow	6 gpm at 3000 psi (23 l/min at 210 bar) <i>Consult factory for flow rating above 3000 psi (210 bar)</i>
Internal Leakage	10 cu in/min. at 3000 psi and 158 SUS (160 cc/min at 210 bar and 34 cSt)
Fluid Operating Temp. Range	-4° to 248°F (-20° to 120°C) <i>(Consult factory for usage at temp. outside range.)</i>
Ambient Temperature Range	-4° to 140°F (-20° to 60°C)
Coil Duty Rating	Continuous from 85% to 115% of nominal voltage
Current Draw at 68°F (20°C)	1.5 A at 12VDC; 0.8 A at 24VDC
Minimum Pull-in Current	90% of nominal @ 5000 psi (350 bar)
Fluid Compatibility	Mineral-based or synthetics with lubricating properties
Viscosity	50 to 2000 SUS (7.4 to 420 cSt)
Filtration	21/19/16 or cleaner (per ISO 4406). Use with filter rated $\beta_{10} \geq 200$.
Installation	No orientation restrictions
Cavity	FC10-4 (see <i>Line Bodies & Cavities</i> section)
Cavity Tools	Rougher: 02580248 Finisher: 02580249
Cartridge Weight	0.64 lbs (0.29 kg)
Coil Weight	0.42 lbs (0.19 kg) - 2 coils required
Cartridge Material	Steel with hardened work surfaces. Zinc-plated exposed surfaces. Buna N or Viton® o-rings. PTFE back-up rings.
Coil Material	Class H high temperature magnetwire, steel shell, polyamide encapsulation.
Seal Kits	Buna-N FS104-N P/N: 03051912 Viton® FS104-V P/N: 03071275

Performance

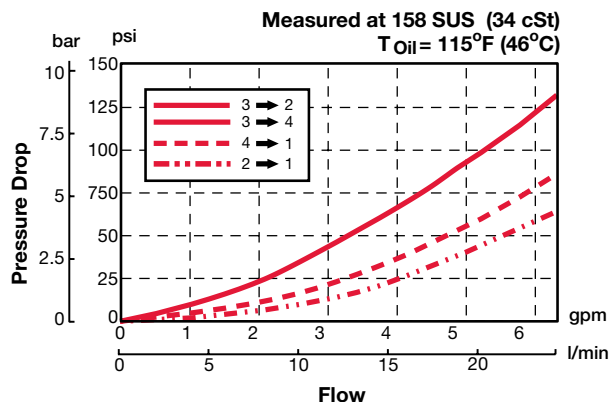

Dimensions

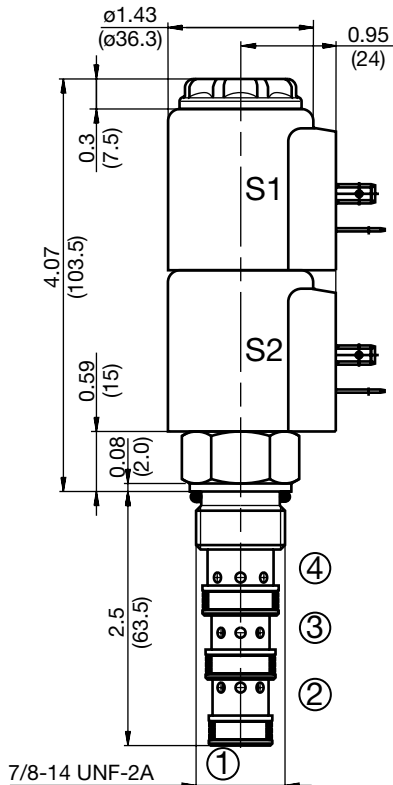
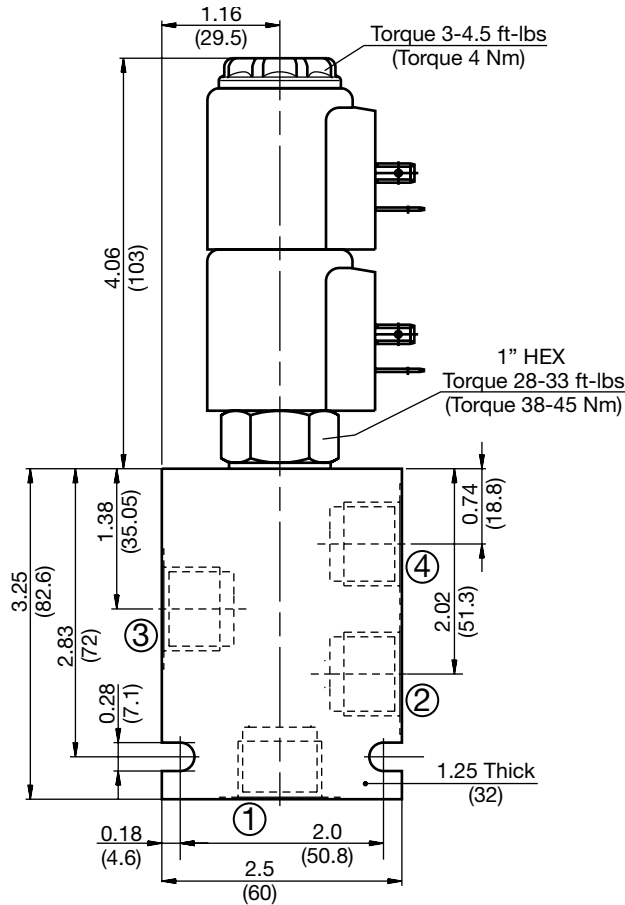

Model Code

WK10J-01-M-C-N-24 DN

Valve Model

Override Option

- (omit) = No manual override
- M = Push/pull type, not detented
- A = Push/pull type, detented

Body & Ports

- C = Cartridge only
- AS8 = SAE-8 ports, aluminum body
- SS8 = SAE-8 ports, steel body

Seals

- N = Buna-N
- V = Viton®

Coil Voltage

- 0 = No coil, cartridge only
- DC 12 = 12 VDC
- 24 = 24 VDC
- 36 = 36 VDC
- 110 = 110 VDC (only available with connector DG)
- AC 24 = 24 VAC
- 115 = 115 VAC
- 230 = 230 VAC

Coil Connector

- DC DG = EN 175301-803-A
- DS = Dual spade (SAEJ858a)*
- DL = Leadwires (2) - 18" long (46 cm)*
- DW = WeatherPak™ on leadwires - 9.5" long (24 cm)*
- DN = Deutsch™ DT04-2P, molded, axial (IP69K Rated)*
- DT = Amp Junior Timer™, molded, radial mount*

AC AG = EN 175301-803-A

Coil Model

40-1836, 2 per assembly

For other coil connector types consult factory

*Coils with internal diode are available, consult factory.

Manual Override Options

Option M - Non Detented

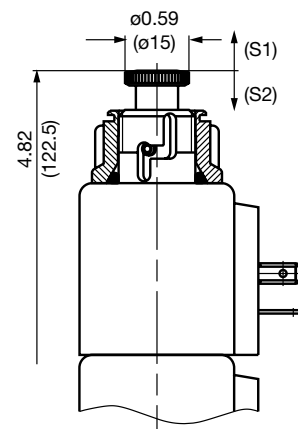

Option A - Detented

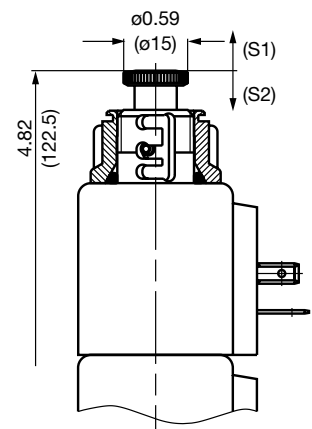

Standard Line Bodies*

Code	Part No	Material	Pressure Rating	Weight
FH104-AS8	03038110	Aluminum, anodized	3500 psi (245 bar)	0.72 lb (0.33 kg)
FH104-SS8	03037868	Steel, zinc plated	6000 psi (420 bar)	2.12 lb (0.96 kg)

*Please refer to Line Bodies & Cavities section for details

All measurements in inches (mm).
Subject to technical modifications

SOLENOID VALVES

WK10T-01

Spool Type, Direct Acting

Up to 6 gpm (23 l/min) • 5000 psi (350 bar)

Hydraulic Symbol

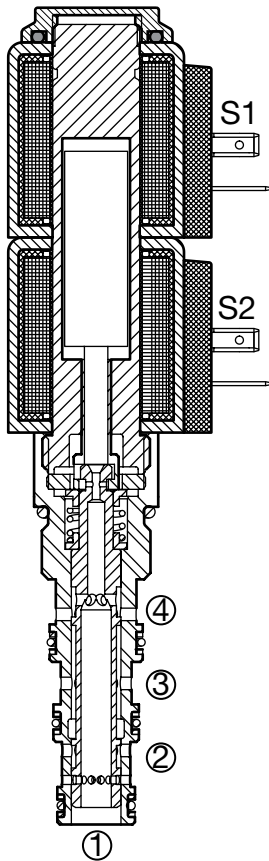
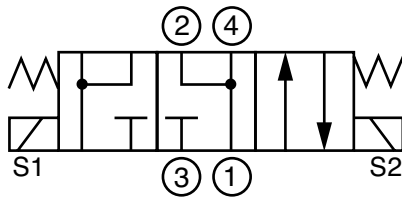

Description

A screw-in cartridge, solenoid operated, 4-way, 3 position, direct acting, spool type valve.

Operation

When de-energized the WK10T allows flow from cylinder ports 2 and 4 to port 1, port 3 is blocked. When coil S1 is energized the spool shifts and allows flow from port 3 to port 2 and port 4. When coil S2 is energized the spool shifts and allows flow from port 3 to port 2 and from port 4 to port 1.

Operation of Manual Override Option: To override, twist knurled screw and push or pull to shift spool.

Detented version - twist again after pushing/pulling to hold position.

Features

- Push/pull type manual override button, detented manual override option.

Specifications

Operating Pressure	5000 psi (350 bar)
Nominal Flow	6 gpm at 3000 psi (23 l/min at 210 bar) <i>Consult factory for flow rating above 3000 psi (210 bar)</i>
Internal Leakage	10 cu in/min. at 3000 psi and 158 SUS (160 cc/min at 210 bar and 34 cSt)
Fluid Operating Temp. Range	-4° to 248°F (-20° to 120°C) <i>(Consult factory for usage at temp. outside range.)</i>
Ambient Temperature Range	-4° to 140°F (-20° to 60°C)
Coil Duty Rating	Continuous from 85% to 115% of nominal voltage
Current Draw at 68°F (20°C)	1.5 A at 12VDC; 0.8 A at 24VDC
Minimum Pull-in Current	85% of nominal @ 5000 psi (350 bar)
Fluid Compatibility	Mineral-based or synthetics with lubricating properties
Viscosity	50 to 2000 SUS (7.4 to 420 cSt)
Filtration	21/19/16 or cleaner (per ISO 4406). Use with filter rated $\beta_{10} \geq 200$.
Installation	No orientation restrictions
Cavity	FC10-4 (see <i>Line Bodies & Cavities</i> section)
Cavity Tools	Rougher: 02580248 Finisher: 02580249
Cartridge Weight	0.64 lbs (0.29 kg)
Coil Weight	0.42 lbs (0.19 kg) - 2 coils required
Cartridge Material	Steel with hardened work surfaces. Zinc-plated exposed surfaces. Buna N or Viton® o-rings. PTFE back-up rings.
Coil Material	Class N high temperature magnet wire, steel shell, polyamid encapsulation.
Seal Kits	Buna-N FS104-N P/N: 03051912 Viton® FS104-V P/N: 03071275

Performance

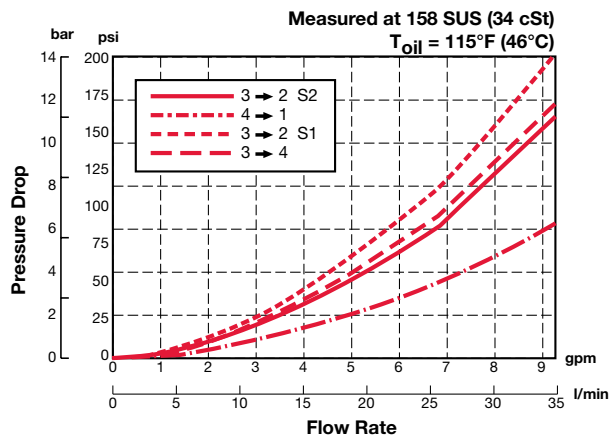

Dimensions

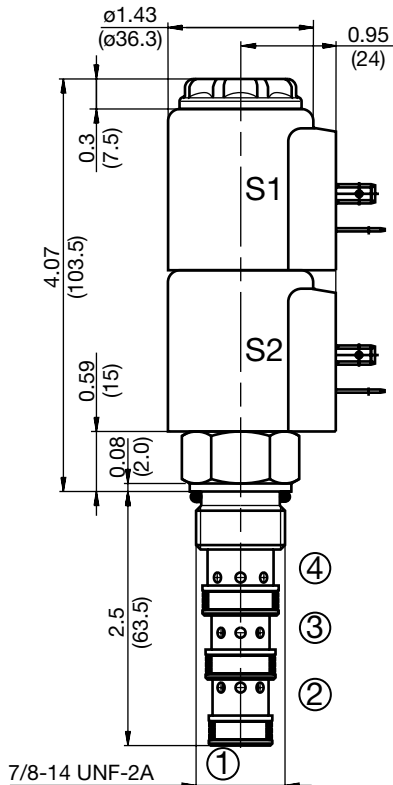
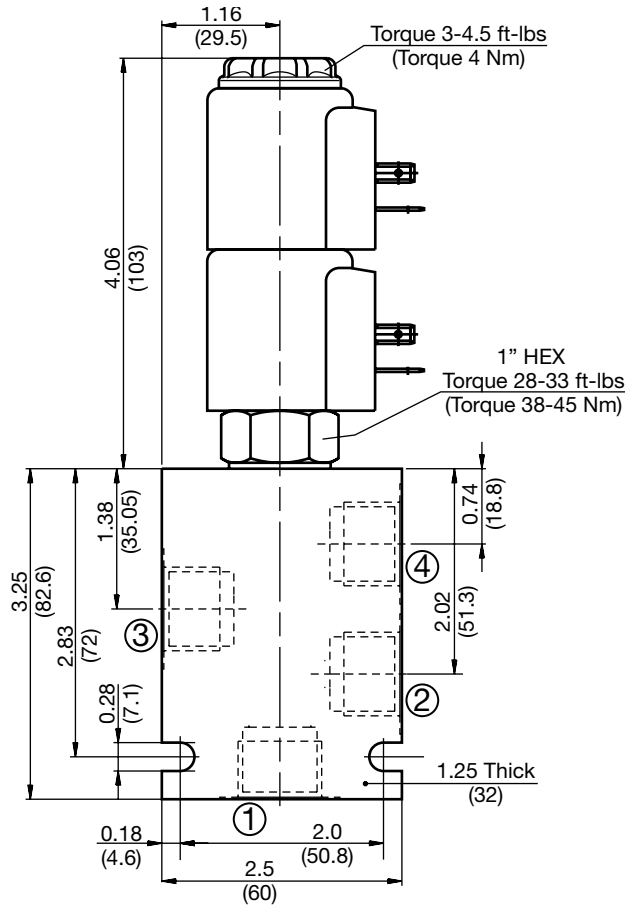

Model Code

WK10T-01-M-C-N-24 DN

Valve Model

Override Option

- (omit) = No manual override
- M = Push/pull type, not detented
- A = Push/pull type, detented

Body & Ports

- C = Cartridge only
- AS8 = SAE-8 ports, aluminum body
- SS8 = SAE-8 ports, steel body

Seals

- N = Buna-N
- V = Viton®

Coil Voltage

- 0 = No coil, cartridge only
- DC 12 = 12 VDC
- 24 = 24 VDC
- 36 = 36 VDC
- 110 = 110 VDC (only available with connector DG)
- AC 24 = 24 VAC
- 115 = 115 VAC
- 230 = 230 VAC

Coil Connector

- DC DG = EN 175301-803-A
- DS = Dual spade (SAEJ858a)*
- DL = Leadwires (2) - 18" long (46 cm)*
- DW = WeatherPak™ on leadwires - 9.5" long (24 cm)*
- DN = Deutsch™ DT04-2P, molded, axial (IP69K Rated)*
- DT = Amp Junior Timer™, molded, radial mount*

AC AG = EN 175301-803-A

Coil Model

40-1836, 2 per assembly

For other coil connector types consult factory

*Coils with internal diode are available, consult factory.

Manual Override Options

Option M - Non Detented

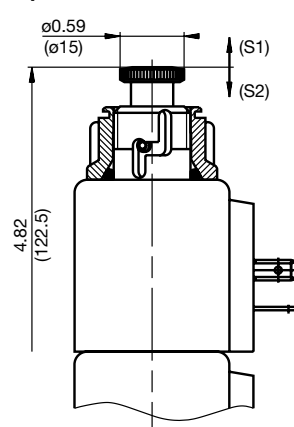

Option A - Detented

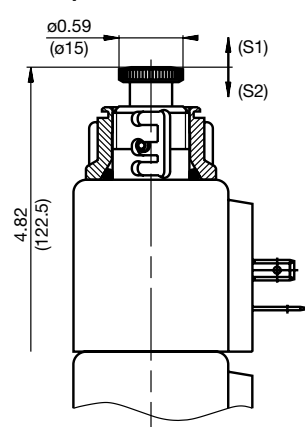

Standard Line Bodies*

Code	Part No	Material	Pressure Rating	Weight
FH104-AS8	03038110	Aluminum, anodized	3500 psi (245 bar)	0.72 lb (0.33 kg)
FH104-SS8	03037868	Steel, zinc plated	6000 psi (420 bar)	2.12 lb (0.96 kg)

*Please refer to Line Bodies & Cavities section for details

All measurements in inches (mm).
Subject to technical modifications

SOLENOID VALVES

Notes

A large grid of empty cells for taking notes.



G1

Overview

HYDAC offers several functions of the Directional Control Cartridges.

- **HYDAC Manually** operated 2 position, 2- way normally closed, spring return, directional valve features poppet design. It offers bi-directional load holding and low internal leakage. Models are available for flows up to 5 gpm (20 lpm) with pressure rating up to 3600 psi (250 bar)
- **HYDAC Piloted** 3-way hydraulically operated spool type directional valve used for functions requiring remote pilot actuation. Models are available for flow rates up to 70 gpm (265 lpm) with pressure rating up to 5000 psi (350 bar).

Features

- Hardened spool or poppet to ensure extended service life.
- All external surfaces zinc-plated



DIRECTIONAL CONTROL VALVES

WS08WM-01

Poppet Bi-directional, Push to Operate, Manually Operated

Up to 5 gpm (20 l/min) • 3600 psi (250 bar)

Hydraulic Symbol

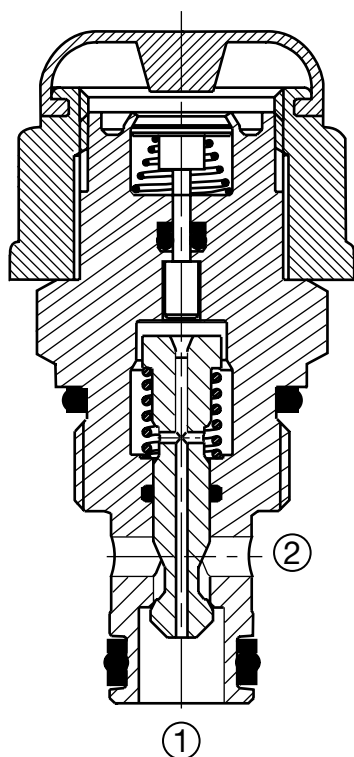
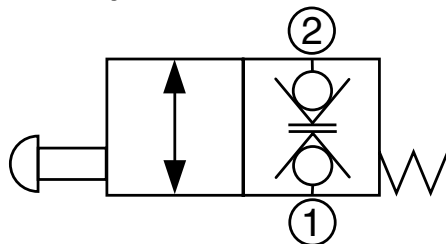

Description

A screw-in cartridge, manually operated, 2-way, 2 position, normally closed, direct acting, poppet type, intended for use as a bi-directional load holding device in hydraulic circuits requiring manual operation and low internal leakage.

Operation

The WS08WM-01 blocks flow, leakfree, in both directions until an operator pushes the button against the bias spring and opens the flow path between port 2 to port 1 bi-directionally. The flow path will be open as long as the plastic button is pushed down.

Features

- Both ports could be fully pressurized
- Easy to operate manually
- Spring return
- Push type manual override button, protected by rubber cap

Specifications

Operating Pressure	3600 psi (250 bar)
Nominal Flow	5 gpm (20 l/min)
Internal Leakage	Leaktight, less than 5 drops/min. at 3600 psi (0.25 cc/min at 250 bar)
Required Push Force	9 to 15 Lbs (40 to 70 N) depending on operating pressure
Fluid Operating Temp Range	-4° to 248°F (-20° to 120°C) <i>(Consult factory for usage at temp. outside range.)</i>
Ambient Temperature Range	-4° to 140°F (-20° to 60°C)
Fluid Compatibility	Mineral-Based or synthetics with lubricating properties.
Viscosity	50 to 2000 SUS (7.4 to 420 cSt)
Filtration	21/19/16 or cleaner per (ISO 4406) Use with filter rated $\beta_{10} \geq 200$
Installation	No orientation restrictions
Cavity	FC08-2 (see <i>Line Bodies & Cavities</i> section)
Cavity Tools	Rougher: 02580090 Finisher: 02580091
Cartridge Weight	0.19 lbs (0.09 kg)
Cartridge Material	Steel with hardened work surfaces. Zinc plated exposed surfaces. Buna N or Viton® o-rings. PTFE back-up rings.
Seal Kits	Buna-N FS082-N P/N: 03033920 Viton® FS082-V P/N: 03051756

Performance

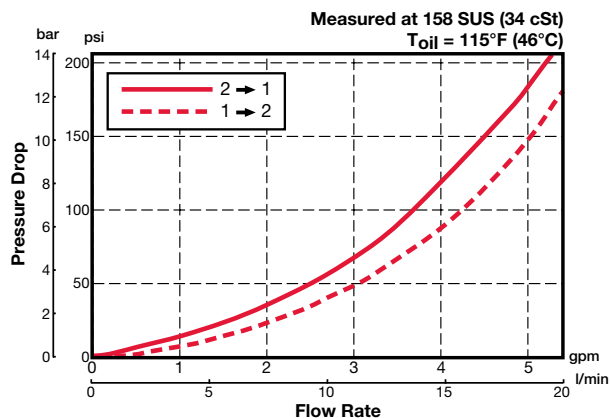

DIRECTIONAL CONTROL VALVES

Dimensions

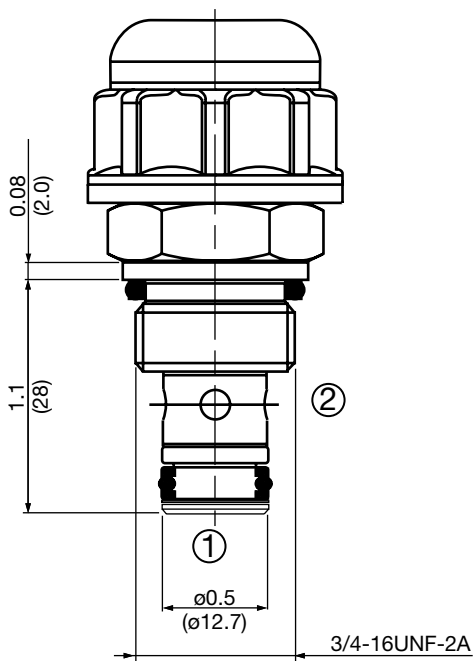
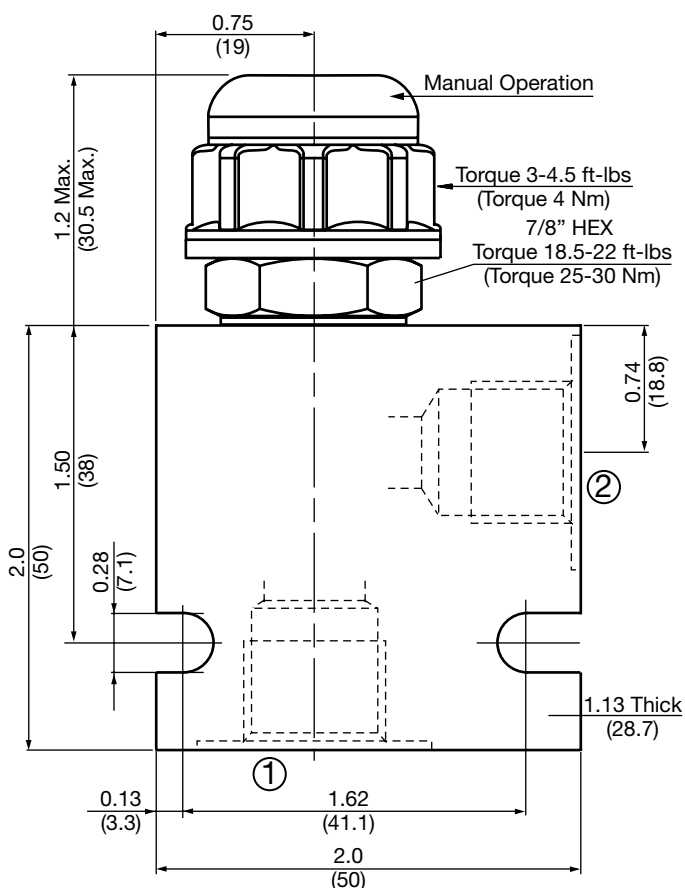

All measurements in inches (mm).
*Subject to technical modifications

Model Code

WS08WM-01-C-N

Valve Model

Body & Ports

- C = Cartridge only
- AS6 = SAE-6 ports, aluminum Body
- SS6 = SAE-6 ports, steel Body

Seals

- N = Buna-N
- V = Viton®

Standard Line Bodies*

Code	Part No	Material	Pressure Rating	Weight
FH082-AS6	03011409	Aluminum, anodized	3500 psi (245 bar)	0.34 lbs (0.15 kg)
FH082-SS6	00560917	Steel, zinc plated	6000 psi (420 bar)	1.0 lbs (0.45 kg)

*Please refer to Line Bodies & Cavities section for details

DIRECTIONAL CONTROL VALVES

HPM45SE-01

Piloted 3-Way Spool, Hydraulically Operated

70 gpm (265 lpm) • 5000 psi (350 bar)

Hydraulic Symbol

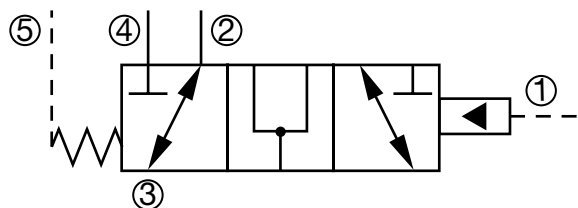

Description

A screw-in cartridge valve, spool type, hydraulically pilot operated directional valve for three way functions requiring remote pilot actuation.

Operation

When pilot pressure is applied to port 1, the spool begins to shift redirecting the flow from port 3 to port 2 to port 3 to port 4. Pressure at port 5 is additive to the spring bias.

Features

- Hardened spool and body to ensure extended service life and low leakage
- All external surfaces zinc-plated

Specifications

Operating Pressure	5000 psi (350 bar)
Nominal Flow	70 gpm (265 l/min) at 100 psi (7 bar) ΔP
Fluid Operating Temp. Range	-20° to 248°F (-29° to 120°C)
Ambient Temperature Range	-20° to 248°F (-29° to 120°C)
Fluid Compatibility	Mineral-Based or synthetics with lubricating properties.
Viscosity	50 to 2000 SUS (7.4 to 420 cSt)
Filtration	21/19/16 or cleaner per (ISO 4406)
Installation	No orientation restrictions
Cavity	FCM45-5 (see <i>Line Bodies & Cavities section</i>)
Cavity Tools	Rougher: 02582020 Finisher: 02582021
Cartridge Weight	2.31 lbs (1.05 kg)
Cartridge Material	Steel with hardened work surfaces. Zinc plated exposed surfaces. Buna N or Viton® o-rings. PTFE back-up rings.
Seal Kits	Buna-N P/N: 02610313 Viton® P/N: 02610314

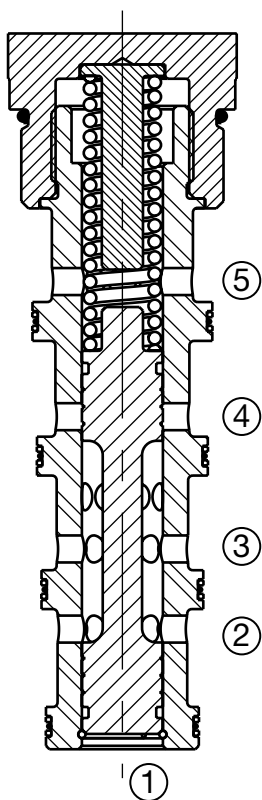

Performance

Measured at 135 SUS (28 cSt)
T_{oil} = 100°F (38°C)

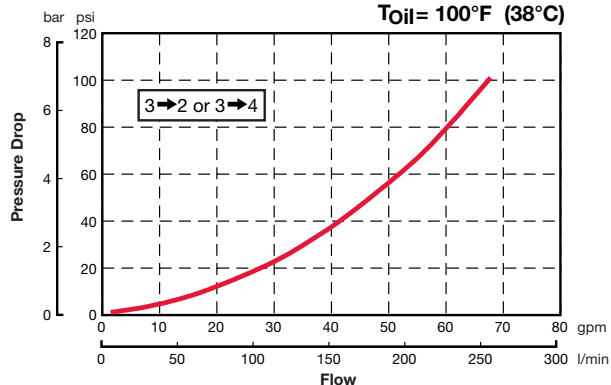

DIRECTIONAL CONTROL VALVES

Dimensions

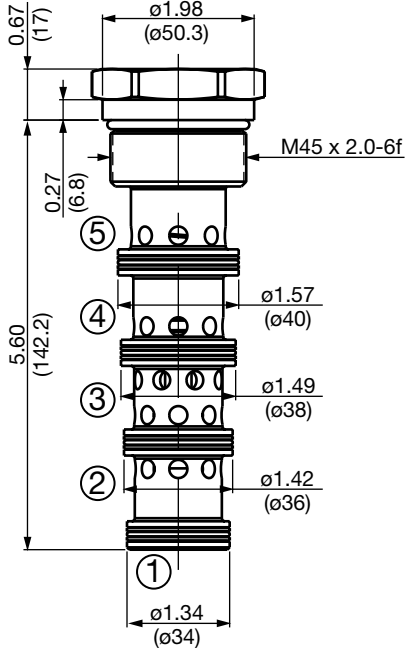
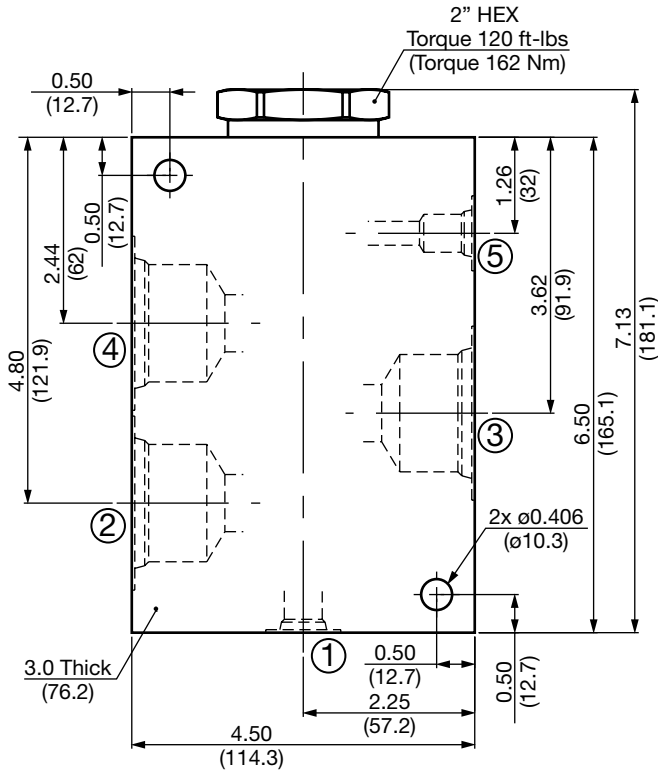

Model Code

HPM45SE-01-SS20-N-150

Valve Model

Body & Ports

- C = Cartridge only
- AS20 = SAE-20 Ports, Aluminum Body
- SS20 = SAE-20 Ports, Steel Body
(Ports 1 & 5 = SAE-6)

Seals

- N = Buna-N
- V = Viton®

Bias Spring*

- 150 = 150 psi

*Consult factory for alternative bias springs.

All measurements in inches (mm).
*Subject to technical modifications

Standard Line Bodies*

Code	Part No	Material	Pressure Rating	Weight
FHM455-AS20	02600747	Aluminum, anodized	3500 psi (245 bar)	5.88 lbs (2.66 kg)
FHM455-SS20	02600563	Steel, zinc plated	5000 psi (350 bar)	17.13 lbs (7.77 kg)

*Please refer to Line Bodies & Cavities section for details

DIRECTIONAL CONTROL VALVES

Notes

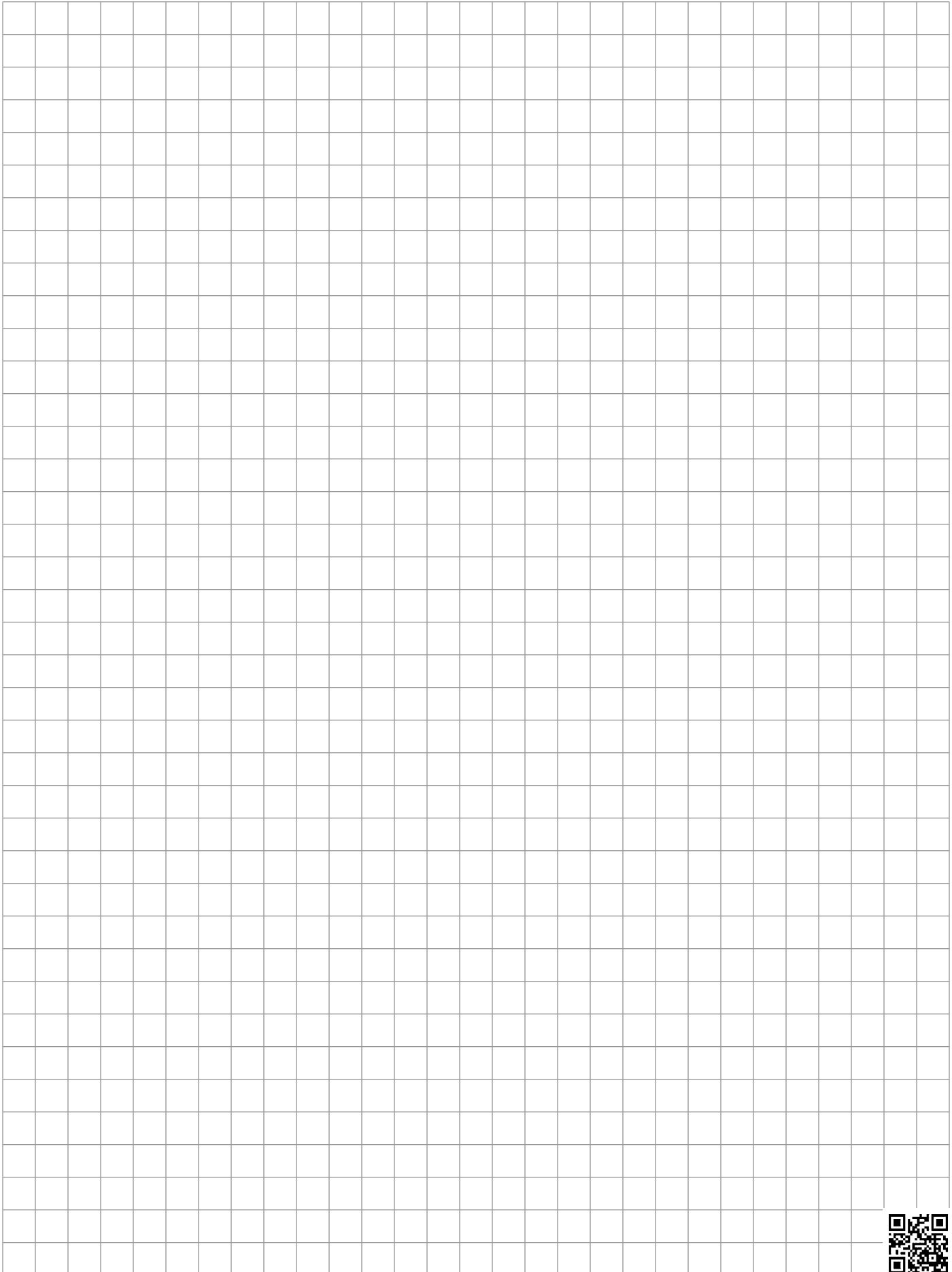
A large grid of graph paper for taking notes, consisting of 20 columns and 30 rows of small squares. A solid red vertical bar is located on the left edge of the page, partially overlapping the grid.

H1

Overview

HYDAC offers a wide range of **Electrically Operated Proportional Pressure Relief Valves and Pressure Reducing/Relieving Valves**.

These proportional valves vary the output pressure in response to a variable electric input.

HYDAC electrically controlled, pilot operated proportional pressure relief valves are available with pressure ranges up to 5000 psi (350 bar). Models are available for flow rates up to 79 gpm (300 lpm).

HYDAC electrically controlled, direct acting and pilot operated proportional pressure reducing/relieving valves are available with pressure ranges from 200 psi (14 bar) up to 5000 psi (350 bar). Models are available for flow rates up to 16 gpm (60 lpm). Pressure control valves can be used to regulate the pressure applied to hydraulic actuators.

Electric current controls with PWM are recommended to be used for **HYDAC Proportional Valves**.

Features

- Wet armature construction
- Hardened operating parts to ensure minimal wear and extend service life
- One piece cartridge body design to maximize reliability
- Screen on pilot orifice to enhance safety
- Excellent stability throughout flow range
- Proportional water/weather resistant coils rated up to IP69K
- Continuous duty rated coils
- Optional coil voltages and molded-in connectors
- Air bleed screws
- All exposed cartridge surfaces zinc-plated to resist corrosion
- Industry common cavity
- Compact size
- Wide voltage range
- Cartridges are voltage interchangeable
- Low pressure drop



PROPORTIONAL VALVES

PDB08P-01

Pressure Relief, Pilot Operated, Spool Type

16 gpm (60 l/min) • 5000 psi (350 bar)

Hydraulic Symbol

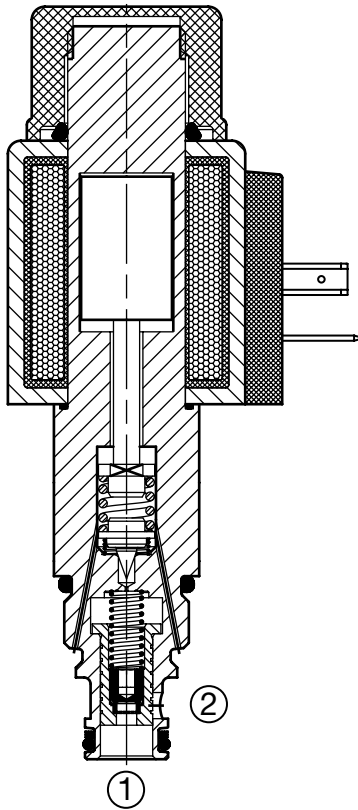
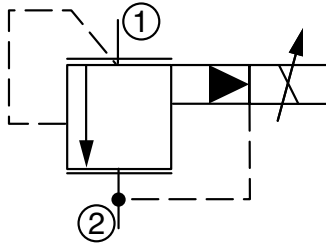

Description

A screw-in cartridge, pilot operated, spool type, pressure relief valve, intended for use as a pressure limiting device. This valve can be infinitely adjusted across a specified range using a variable electric input. Pressure output is proportional to DC current input.

Operation

The PDB08P-01 blocks flow from port 1 to port 2 until sufficient pressure is reached at port 1 to open the pilot stage by offsetting the electrically induced solenoid force. The pilot stage opens and allows flow from the back of the main piston to port 2. The resulting pressure imbalance causes the main spool to move against the return spring and allows flow from port 1 to port 2.

Electrical current increase will increase the relief pressure setting. With no current applied to the solenoid, the valve will relieve at approximately 75 psi.

Features

- Excellent stability throughout flow range
- 12 and 24 volt proportional waterproof coils
- Screen on pilot orifice to enhance safety
- Manual override option

Specifications

Operating Pressure	5000 psi (350 bar) max at port 2
Nominal Flow	16 gpm (60 l/min)
Maximum Pilot Flow	3.75 cu in/min. (0.5 l/min)
Relieving Pressure Ranges (0 to maximum control current)	75 to 870 psi (5 to 60 bar) 75 to 3300 psi (5 to 230 bar) 75 to 5000 psi (5 to 350 bar)
Maximum Control Current	2.1 amps for 12VDC coil (2.2 Ohms) 1.05 amps for 24VDC coil (8.8 Ohms)
Dither Frequency	160 to 250 Hz
Hysteresis With Dither	2-4% of maximum control current
Typical Step Response Time	ON: approx 50 ms, OFF: approx. 30 ms
Repeatability	<= 1.5% of maximum pressure range
Reversal Span	<= 2% of maximum
Response Sensitivity	<= 1% of maximum control current
Ambient Temperature Range	-4° to 140°F (-20° to 60°C)
Fluid Operating Temp. Range	-4° to 248°F (-20° to 120°C) (Consult factory for usage at temp. outside range.)
Fluid Compatibility	Mineral-based or synthetics with lubricating properties
Viscosity	50 to 2000 SUS (7.4 to 420 cSt)
Filtration	18/16/13 or cleaner (per ISO 4406) Use with filter rated $\beta_3 \geq 200$.
Installation	No orientation restrictions
Cavity	FC08-2 (see Line Bodies & Cavities section)
Cavity Tools	Rougher: 02580090 Finisher: 02580091
Cartridge Weight	0.44 Lbs. (0.20 kg)
Coil Weight	0.42 Lbs. (0.19 kg)
Cartridge Material	Steel with hardened work surfaces. Zinc-plated exposed surfaces. Buna N or Viton® o-rings, and PTFE back-up rings.
Coil Material	Class N high temperature magnet wire steel shell, polyamid encapsulation
Seal Kits	Buna-N P/N: 03033920 Viton® P/N: 03031756

Performance

Measured at 158 SUS (34 cSt)
T_{oil} = 115°F (46°C)

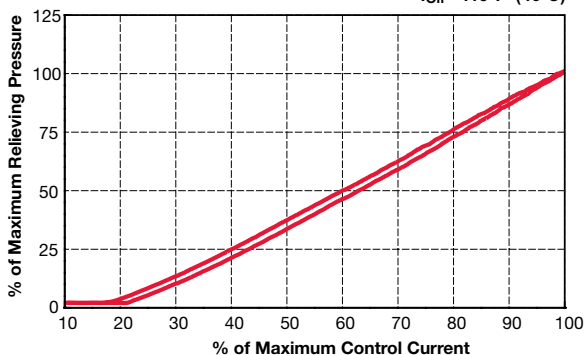

Dimensions

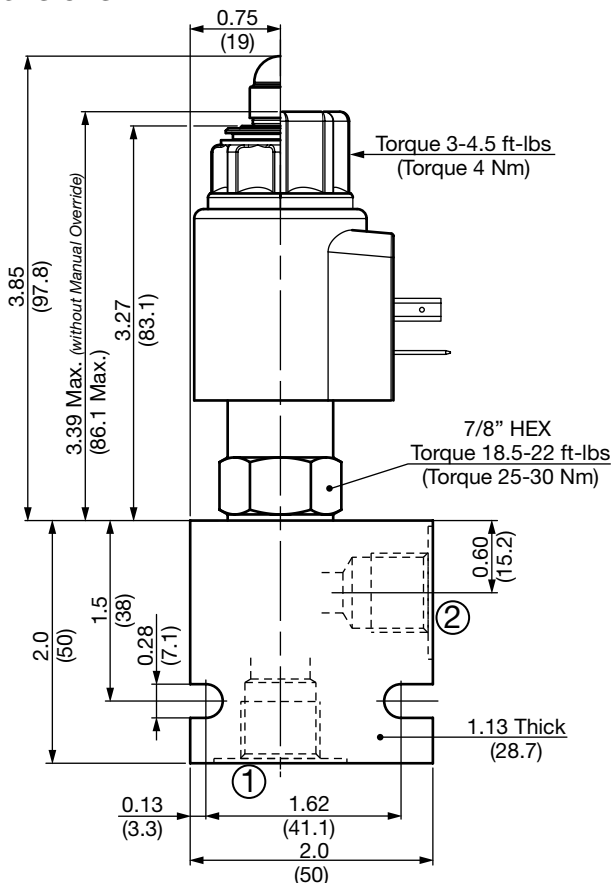

Manual Override
(Emergency pressure adjustment)
Torque 7.4-8.1 ft-lbs
(Torque 10-11 Nm)

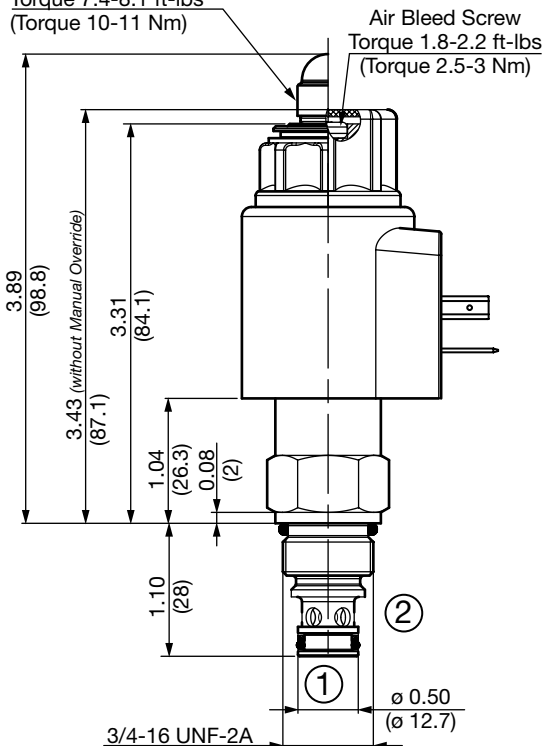

All measurements in inches (mm).
Subject to technical modifications

Model Code

PDB08P-01-M-C-N-330-24 PG 8.8

Valve Model	_____
Override Options	_____
(omit) = No manual override	
M = Manual override	
Body & Ports	_____
C = Cartridge only	
AS6 = SAE-6 ports, aluminum body	
SS6 = SAE-6 ports, steel body	
Seals	_____
N = Buna-N	
V = Viton®	
Pressure Range	_____
87 = 75 to 870 psi (5 to 60 bar)	
330 = 75 to 3300 psi (5 to 230 bar)	
500 = 75 to 5000 psi (5 to 350 bar)	
Coil Voltage	_____
0 = No coil, cartridge only	
12 = 12 VDC	
24 = 24 VDC	
Coil Connector	_____
PG = EN 175301-803-A	
PL = Leadwires (2) - 18" long (46 cm)	
PN = Deutsch™ DT04-2P, molded, axial (IP69K Rated)	
PT = Amp Junior Timer™, molded, radial mount	
Coil Resistance	_____
2.2 = 2.2 Ohms (12 VDC)	
8.8 = 8.8 Ohms (24 VDC)	
Coil Model	P-40-1836
<i>For other coil connector types consult factory</i>	

Performance

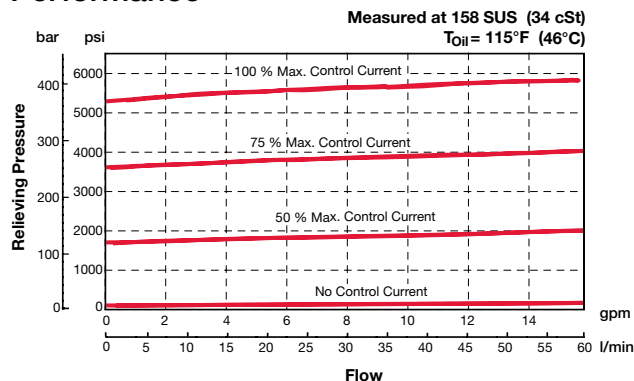

Standard Line Bodies*

Code	Part No	Material	Pressure Rating	Weight
FH082-AS6	03011409	Aluminum, anodized	3500 psi (245 bar)	0.34 lb (0.15 kg)
FH082-SS6	00560917	Steel, zinc plated	6000 psi (420 bar)	1.0 lb (0.45 kg)

*Please refer to Line Bodies & Cavities section for details

PROPORTIONAL VALVES

PDB10P-01

Pressure Relief, Pilot Operated, Spool Type

31 gpm (120 l/min) • 5000 psi (350 bar)

Hydraulic Symbol

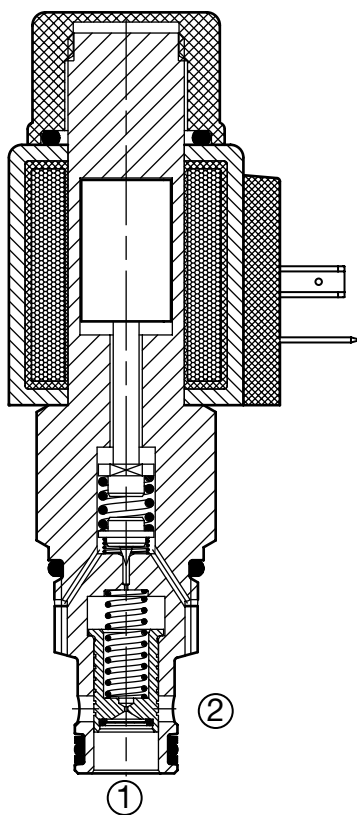
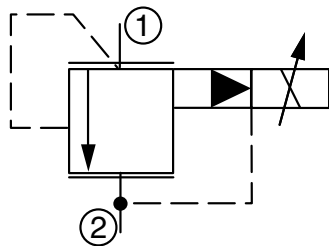

Description

A screw-in cartridge, pilot operated, spool type, pressure relief valve, intended for use as a pressure limiting device. This valve can be infinitely adjusted across a specified range using a variable electric input. Pressure output is proportional to DC current input.

Operation

The PDB10P-01 blocks flow from port 1 to port 2 until sufficient pressure is reached at port 1 to open the pilot stage by offsetting the electrically induced solenoid force. The pilot stage opens and allows flow from the back of the main piston to port 2. The resulting pressure imbalance causes the main spool to move against the return spring and allows flow from port 1 to port 2.

Electrical current increase will increase the relief pressure setting. With no current applied to the solenoid, the valve will relieve at approximately 75 psi.

Features

- Excellent stability throughout flow range
- 12 and 24 volt proportional waterproof coils
- Screen on pilot orifice to enhance safety
- Manual override option

Specifications

Operating Pressure	5000 psi (350 bar) max at port 2
Nominal Flow	31 gpm (120 l/min)
Maximum Pilot Flow	3.75 cu in/min. (0.5 l/min)
Relieving Pressure Ranges (0 to maximum control current)	75 to 870 psi (5 to 60 bar) 75 to 3300 psi (5 to 230 bar) 75 to 5000 psi (5 to 350 bar)
Maximum Control Current	2.1 amps for 12VDC coil (2.2 Ohms) 1.05 amps for 24VDC coil (8.8 Ohms)
Dither Frequency	160 to 250 Hz
Hysteresis With Dither	2-4% of maximum control current
Typical Step Response Time	ON: approx 50 ms, OFF: approx. 30 ms
Repeatability	<= 1.5% of maximum pressure range
Reversal Span	<= 2% of maximum
Response Sensitivity	<= 1% of maximum control current
Ambient Temperature Range	-4° to 140°F (-20° to 60°C)
Fluid Operating Temp. Range	-4° to 248°F (-20° to 120°C) (Consult factory for usage at temp. outside range.)
Fluid Compatibility	Mineral-based or synthetics with lubricating properties
Viscosity	50 to 2000 SUS (7.4 to 420 cSt)
Filtration	18/16/13 or cleaner (per ISO 4406) Use with filter rated $\beta_3 \geq 200$.
Installation	No orientation restrictions
Cavity	FC10-2 (see Line Bodies & Cavities section)
Cavity Tools	Rougher: 02580274 Finisher: 02580247
Cartridge Weight	0.57 Lbs. (0.26 kg)
Coil Weight	0.42 Lbs. (0.19 kg)
Cartridge Material	Steel with hardened work surfaces. Zinc-plated exposed surfaces. Buna N or Viton® o-rings, and PTFE back-up rings.
Coil Material	Class N high temperature magnet wire steel shell, polyamid encapsulation
Seal Kits	Buna-N P/N: 03033872 Viton® P/N: 03051757

Performance

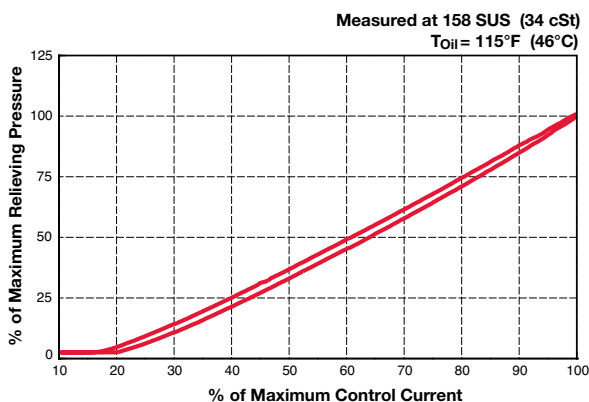

Dimensions

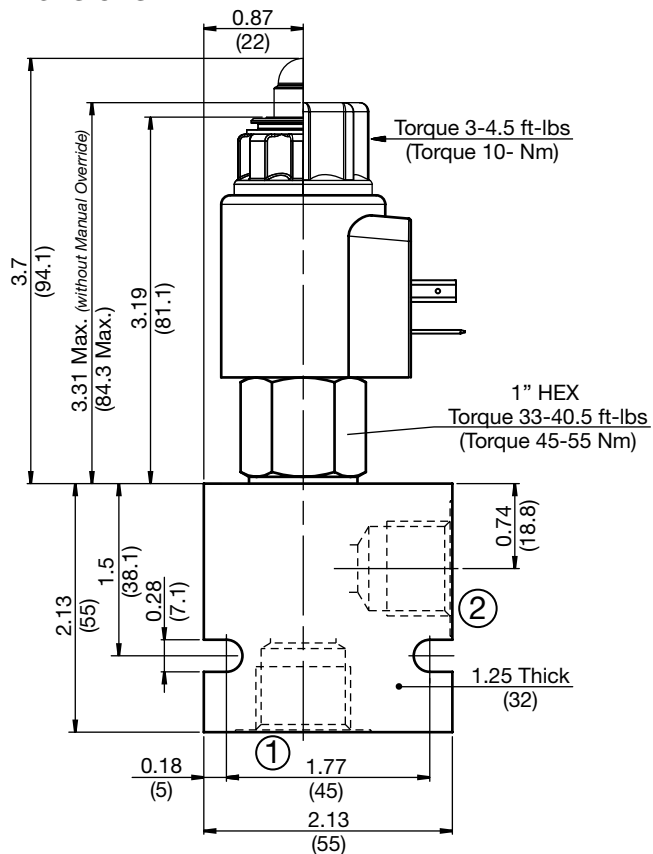

Manual Override (Emergency pressure adjustment)

Torque 7.4-8.1 ft-lbs
(Torque 10-11 Nm)

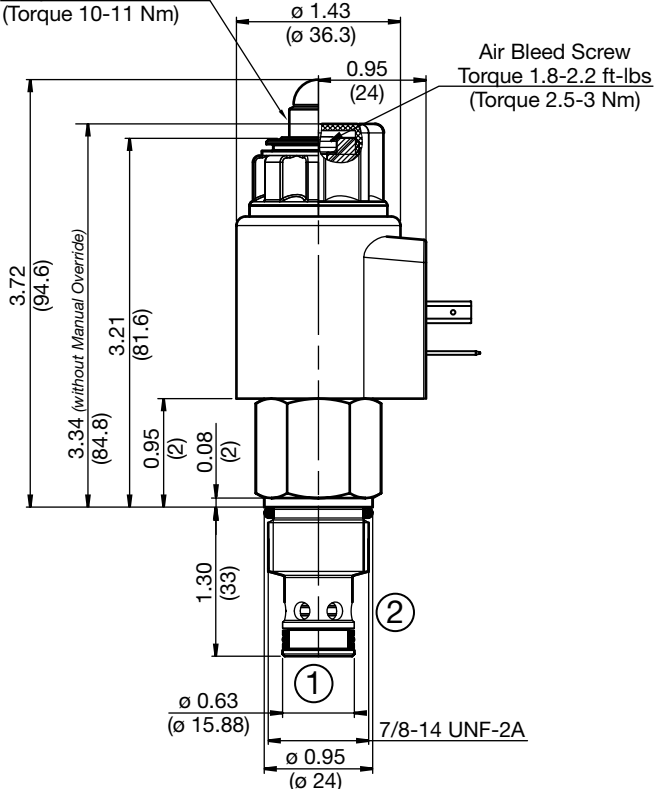

All measurements in inches (mm).
Subject to technical modifications

Model Code

PDB10P-01-M-C-N-330-24 PG 8.8

Valve Model

Override Options

- (omit) = No manual override
- M = Manual override

Body & Ports

- C = Cartridge only
- AS8 = SAE-8 ports, aluminum body
- SS8 = SAE-8 ports, steel body

Seals

- N = Buna-N
- V = Viton®

Pressure Range

- 87 = 75 to 870 psi (5 to 60 bar)
- 330 = 75 to 3300 psi (5 to 230 bar)
- 500 = 75 to 5000 psi (5 to 350 bar)

Coil Voltage

- 0 = No coil, cartridge only
- 12 = 12 VDC
- 24 = 24 VDC

Coil Connector

- PG = EN 175301-803-A
- PL = Leadwires (2) - 18" long (46 cm)
- PN = Deutsch™ DT04-2P, molded, axial (IP69K Rated)
- PT = Amp Junior Timer™, molded, radial mount

Coil Resistance

- 2.2 = 2.2 Ohms (12 VDC)
- 8.8 = 8.8 Ohms (24 VDC)

Coil Model

P-40-1836
For other coil connector types consult factory

Performance

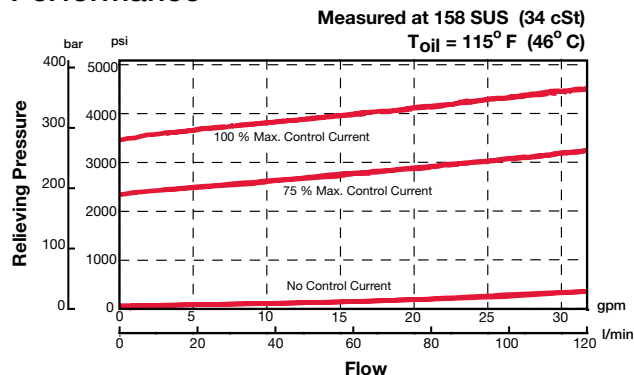

Standard Line Bodies*

Code	Part No	Material	Pressure Rating	Weight
FH102-AS8	03037778	Aluminum, anodized	3500 psi (245 bar)	0.40 lb (0.18 kg)
FH102-SS8	03037612	Steel, zinc plated	6000 psi (420 bar)	1.16 lb (0.53 kg)

*Please refer to Line Bodies & Cavities section for details

PROPORTIONAL VALVES

PDB12P-01

Pressure Relief, Pilot Operated, Spool Type

53 gpm (200 l/min) • 5000 psi (350 bar)

Hydraulic Symbol

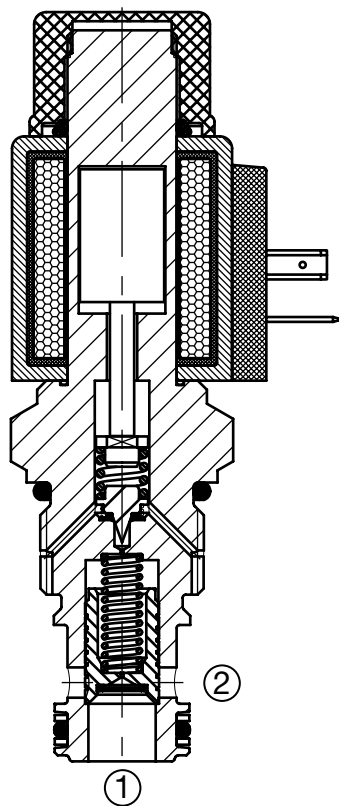
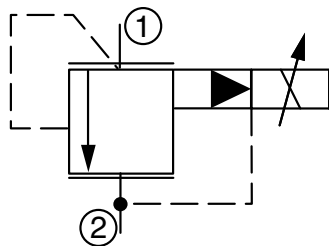

Description

A screw-in cartridge, pilot operated, spool type, pressure relief valve, intended for use as a pressure limiting device. This valve can be infinitely adjusted across a specified range using a variable electric input. Pressure output is proportional to DC current input.

Operation

The PDB12P-01 blocks flow from port 1 to port 2 until sufficient pressure is reached at port 1 to open the pilot stage by offsetting the electrically induced solenoid force. The pilot stage opens and allows flow from the back of the main piston to port 2. The resulting pressure imbalance causes the main spool to move against the return spring and allows flow from port 1 to port 2.

Electrical current increase will increase the relief pressure setting. With no current applied to the solenoid, the valve will relieve at approximately 25 psi.

Features

- Excellent stability throughout flow range
- 12 and 24 volt proportional waterproof coils
- Screen on pilot orifice to enhance safety
- Manual override option

Specifications

Operating Pressure	5000 psi (350 bar) max at port 2
Nominal Flow	53 gpm (200 l/min)
Maximum Pilot Flow	3.75 cu in/min. (0.5 l/min)
Relieving Pressure Ranges (0 to maximum control current)	75 to 870 psi (5 to 60 bar) 75 to 3300 psi (5 to 230 bar) 75 to 5000 psi (5 to 350 bar)
Maximum Control Current	2.1 amps for 12VDC coil (2.2 Ohms) 1.05 amps for 24VDC coil (8.8 Ohms)
Dither Frequency	160 to 250 Hz
Hysteresis With Dither	2-4% of maximum control current
Typical Step Response Time	ON: approx 50 ms, OFF: approx. 30 ms
Repeatability	<= 1.5% of maximum pressure range
Reversal Span	<= 2% of maximum
Response Sensitivity	<= 1% of maximum control current
Ambient Temperature Range	-4° to 140°F (-20° to 60°C)
Fluid Operating Temp. Range	-4° to 248°F (-20° to 120°C) (Consult factory for usage at temp. outside range.)
Fluid Compatibility	Mineral-based or synthetics with lubricating properties
Viscosity	50 to 2000 SUS (7.4 to 420 cSt)
Filtration	18/16/13 or cleaner (per ISO 4406) Use with filter rated $\beta_3 \geq 200$.
Installation	No orientation restrictions
Cavity	FC12-2 (see Line Bodies & Cavities section)
Cavity Tools	Rougher: 02580668 Finisher: 02580667
Cartridge Weight	0.70 Lbs. (0.32 kg)
Coil Weight	0.42 Lbs. (0.19 kg)
Cartridge Material	Steel with hardened work surfaces. Zinc-plated exposed surfaces. Buna N or Viton® o-rings, and PTFE back-up rings.
Coil Material	Class H high temperature magnetwire steel shell, polyamid encapsulation
Seal Kits	Buna-N P/N: 03071298 Viton® P/N: 03071299

Performance

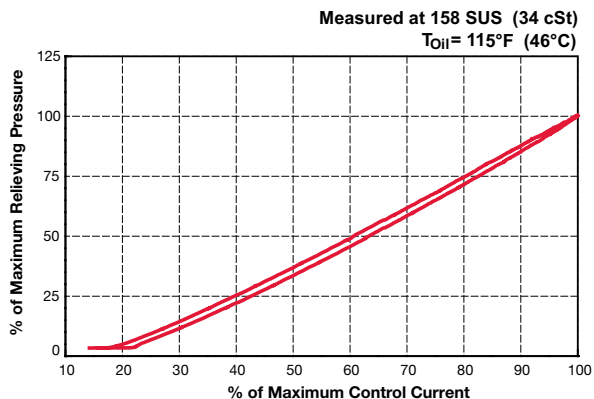

Dimensions

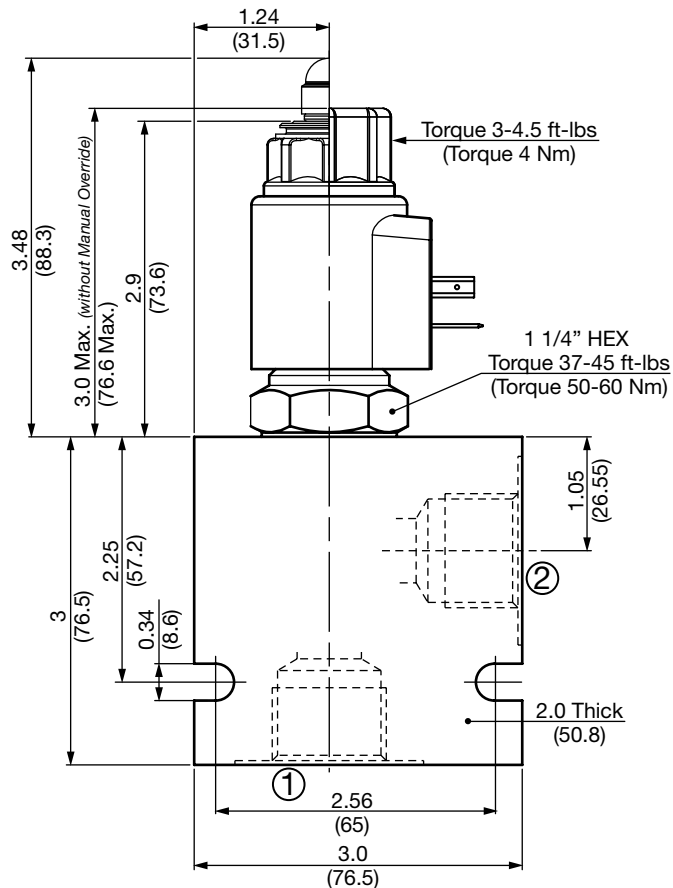

Manual Override (Emergency pressure adjustment)

Torque 7.4-8.1 ft-lbs
(Torque 10-11 Nm)

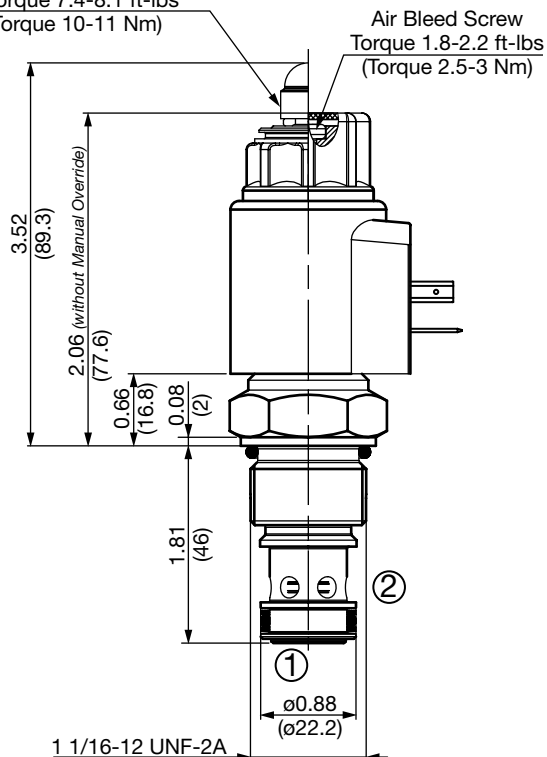

All measurements in inches (mm).
Subject to technical modifications

Model Code

PDB12P-01-M-C-N-330-24 PG 8.8

Valve Model

Override Options

(omit) = No manual override
M = Manual override

Body & Ports

C = Cartridge only
AS12 = SAE-12 ports, aluminum body
SS12 = SAE-12 ports, steel body

Seals

N = Buna-N
V = Viton®

Pressure Range

87 = 75 to 870 psi (5 to 60 bar)
330 = 75 to 3300 psi (5 to 230 bar)
500 = 75 to 5000 psi (5 to 350 bar)

Coil Voltage

0 = No coil, cartridge only
12 = 12 VDC
24 = 24 VDC

Coil Connector

PG = DIN 175301-803
PL = Leadwires (2) - 18" long (46 cm)
PN = Deutsch™ DT04-2P, molded, axial (IP69K Rated)
PT = Amp Junior Timer™, molded, radial mount

Coil Resistance

2.2 = 2.2 Ohms (12 VDC)
8.8 = 8.8 Ohms (24 VDC)

Coil Model

P-40-1836
For other coil connector types consult factory

Performance

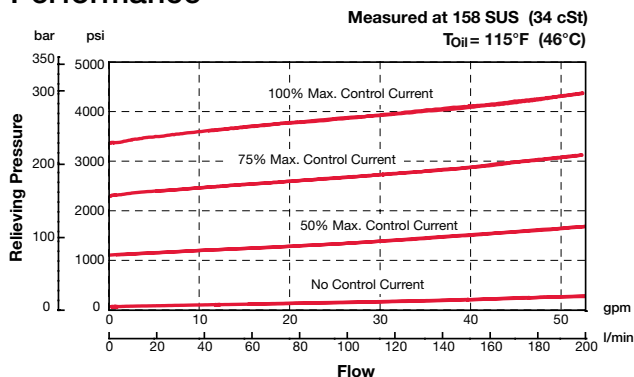

Standard Line Bodies*

Code	Part No	Material	Pressure Rating	Weight
FH122-AS12	03053845	Aluminum, anodized	3500 psi (245 bar)	0.40 lb (0.18 kg)
FH122-SS12	03053772	Steel, zinc plated	6000 psi (420 bar)	1.16 lb (0.53 kg)

*Please refer to Line Bodies & Cavities section for details

PROPORTIONAL VALVES

PDB16P-01

Pressure Relief, Pilot Operated, Spool Type

79 gpm (300 l/min) • 5000 psi (350 bar)

Hydraulic Symbol

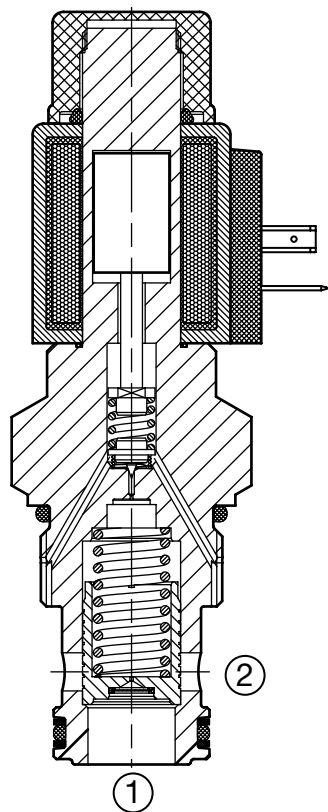
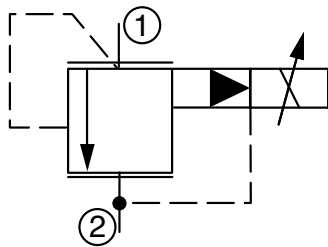

Description

A screw-in cartridge, pilot operated, spool type, pressure relief valve, intended for use as a pressure limiting device. This valve can be infinitely adjusted across a specified range using a variable electric input. Pressure output is proportional to DC current input.

Operation

The PDB16P-01 blocks flow from port 1 to port 2 until sufficient pressure is reached at port 1 to open the pilot stage by offsetting the electrically induced solenoid force. The pilot stage opens and allows flow from the back of the main piston to port 2. The resulting pressure imbalance causes the main spool to move against the return spring and allows flow from port 1 to port 2.

Electrical current increase will increase the relief pressure setting. With no current applied to the solenoid, the valve will relieve at approximately 90 psi.

Features

- Excellent stability throughout flow range
- 12 and 24 volt proportional waterproof coils
- Screen on pilot orifice to enhance safety
- Manual override option

Specifications

Operating Pressure	5000 psi (350 bar) max at port 2
Nominal Flow	79 gpm (300 l/min)
Maximum Pilot Flow	3.75 cu in/min. (0.5 l/min)
Relieving Pressure Ranges (0 to maximum control current)	90 to 870 psi (6 to 60 bar) 90 to 3300 psi (6 to 230 bar) 90 to 5000 psi (6 to 350 bar)
Maximum Control Current	2.1 amps for 12VDC coil (2.2 Ohms) 1.05 amps for 24VDC coil (8.8 Ohms)
Dither Frequency	160 to 250 Hz
Hysteresis With Dither	2-4% of maximum control current
Typical Step Response Time	ON: approx 50 ms, OFF: approx. 30 ms
Repeatability	<= 1.5% of maximum pressure range
Reversal Span	<= 2% of maximum
Response Sensitivity	<= 1% of maximum control current
Ambient Temperature Range	-4° to 140°F (-20° to 60°C)
Fluid Operating Temp. Range	-4° to 248°F (-20° to 120°C) (Consult factory for usage at temp. outside range.)
Fluid Compatibility	Mineral-based or synthetics with lubricating properties
Viscosity	50 to 2000 SUS (7.4 to 420 cSt)
Filtration	18/16/13 or cleaner (per ISO 4406) Use with filter rated $\beta_3 \geq 200$.
Installation	No orientation restrictions
Cavity	FC16-2 (see Line Bodies & Cavities section)
Cavity Tools	Rougher: 02580251 Finisher: 02580250
Cartridge Weight	1.23 Lbs. (0.56 kg)
Coil Weight	0.51 Lbs. (0.23 kg)
Cartridge Material	Steel with hardened work surfaces. Zinc-plated exposed surfaces. Buna N or Viton® o-rings, and PTFE back-up rings.
Coil Material	Class N high temperature magnet wire steel shell, polyamid encapsulation
Seal Kits	Buna-N P/N: 03052427 Viton® P/N: 03051758

Performance

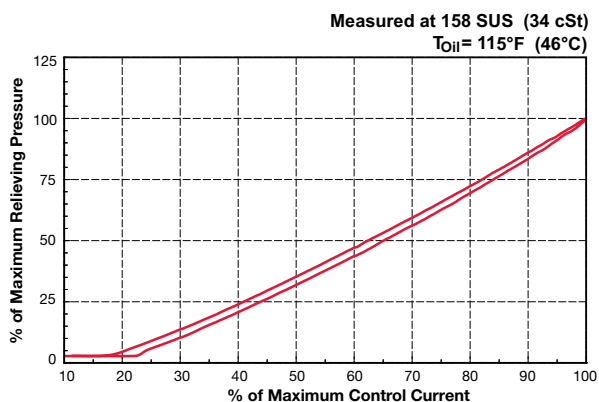

Dimensions

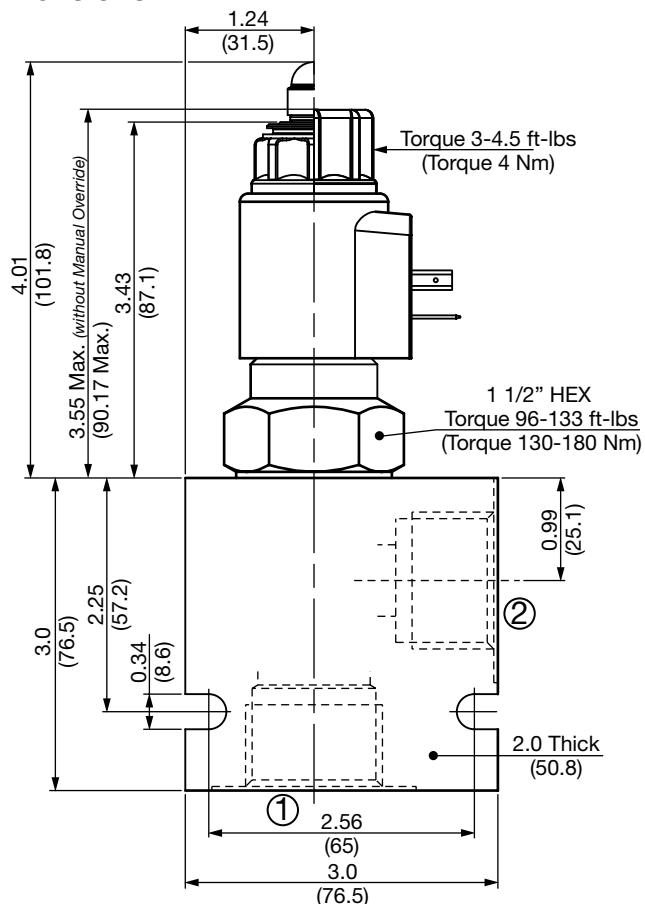

Manual Override

(Emergency pressure adjustment)

Torque 7.4-8.1 ft-lbs

(Torque 10-11 Nm)

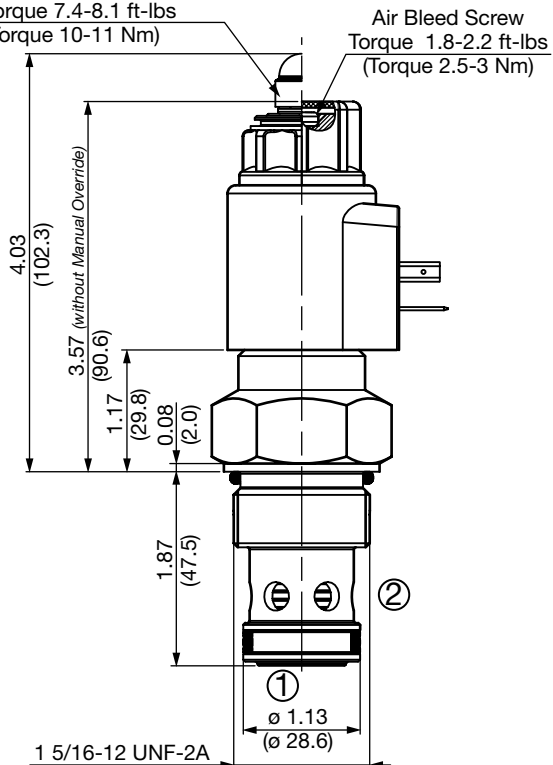

Model Code

PDB16P-01-M-C-N-330-24 PG 8.8

Valve Model

Override Options

(omit) = No manual override
M = Manual override

Body & Ports

C = Cartridge only
AS16 = SAE-16 ports, aluminum body
SS16 = SAE-16 ports, steel body

Seals

N = Buna-N
V = Viton®

Pressure Range

87 = 90 to 870 psi (6 to 60 bar)
330 = 90 to 3300 psi (6 to 230 bar)
500 = 90 to 5000 psi (6 to 350 bar)

Coil Voltage

0 = No coil, cartridge only
12 = 12 VDC
24 = 24 VDC

Coil Connector

PG = EN 175301-803-A
PL = Leadwires (2) - 18" long (46 cm)
PN = Deutsch™ DT04-2P, molded, axial (IP69K Rated)
PT = Amp Junior Timer™, molded, radial mount

Coil Resistance

2.2 = 2.2 Ohms (12 VDC)
8.8 = 8.8 Ohms (24 VDC)

Coil Model

P-40-1836
For other coil connector types consult factory

Performance

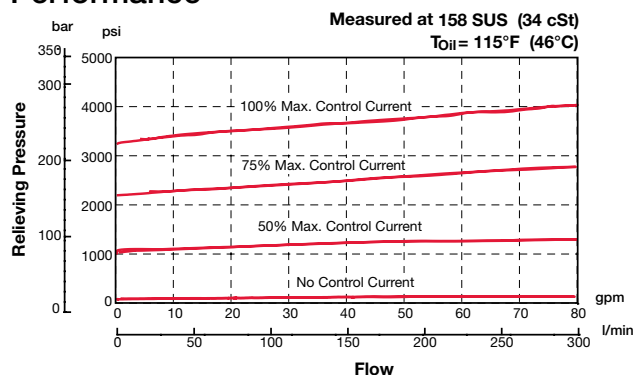

Standard Line Bodies*

Code	Part No	Material	Pressure Rating	Weight
FH162-AS16	03037195	Aluminum, anodized	3500 psi (245 bar)	1.2 lb (0.55 kg)
FH162-SS16	03032655	Steel, zinc plated	6000 psi (420 bar)	3.56 lb (1.62 kg)

*Please refer to Line Bodies & Cavities section for details

All measurements in inches (mm).
Subject to technical modifications

PROPORTIONAL VALVES

PDR08-01

Pressure Reducing/Relieving Direct Acting, Spool Type

3 gpm (12 l/min) • 5000 psi (350 bar)

Hydraulic Symbol

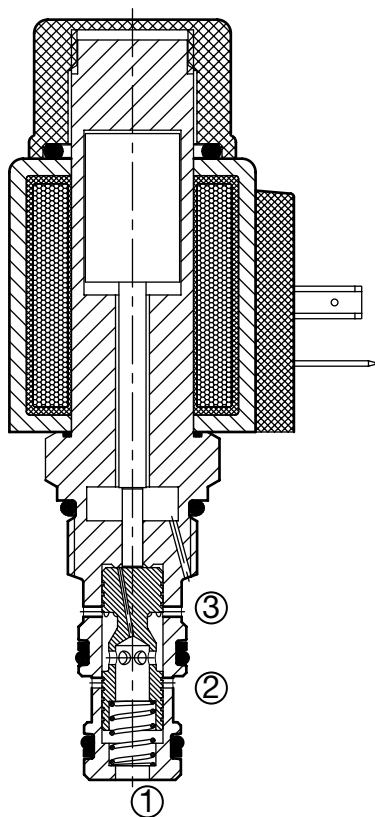
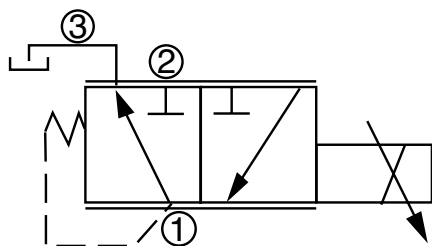

Description

A screw-in cartridge, direct acting, spool type, pressure reducing/relieving valve, intended for use as a pressure control device, which can proportionally control the reduced pressure across the specified range using variable electrical input signal. Reduced pressure output is proportional to DC current input. This valve maintains a constant reduced pressure regardless of pressure variations in the primary system. In addition to the reducing function, this valve also provides a relief function from the reduced pressure port to the tank port if pressure in the secondary circuit exceeds the set pressure.

Operation

When de-energized the PDR08-01 allows flow from port 1 (*reduced pressure port*) to port 3 (*tank*). Port 2 (*inlet*) is blocked. When current signal is applied, the solenoid armature moves the control spool and sets the control (*reduced*) pressure at port 1. Increasing the current applied will increase the reduced pressure proportionally. Port 3 is vented to tank. Back pressure on port 3 is directly additive to the pressure setting.

Specifications

Operating Pressure	5000 psi (350 bar) max at port 2
Nominal Flow	3 gpm (12 l/min)
Flow Path	De-energized: Free flow, 1 to 3 Energized: Reduced, 2 to 1; Relieving, 1 to 3
Internal Leakage	3.75 cu in/min. at 5000 psi and 158 SUS (55 cc/min at 350 bar and 34 cSt)
Reducing/Relieving Pressure Ranges (0 to maximum control current)	0 to 200 psi (0 to 14 bar) 0 to 300 psi (0 to 20 bar) 0 to 500 psi (0 to 35 bar) 0 to 700 psi (0 to 48 bar) 0 to 1100 psi (0 to 75 bar) 0 to 2000 psi (0 to 138 bar)
Maximum Control Current	2.1 amps for 12VDC coil (2.2 Ohms) 1.05 amps for 24VDC coil (8.8 Ohms)
Dither Frequency	160 to 250 Hz
Hysteresis With Dither	2-4% of maximum control current
Typical Step Response Time	ON: approx 40 ms, OFF: approx. 30 ms
Repeatability	<= 2% of maximum pressure range
Reversal Span	<= 2% of maximum
Response Sensitivity	<= 1% of maximum control current
Ambient Temperature Range	-4° to 140°F (-20° to +60°C)
Fluid Operating Temp. Range	-4° to 248°F (-20° to +120°C) (Consult factory for usage at temp. outside range.)
Fluid Compatibility	Mineral-based or synthetics with lubricating properties
Viscosity	50 to 2000 SUS (7.4 to 420 cSt)
Filtration	21/19/16 or cleaner (per ISO 4406). Use with filter rated $\beta_3 \geq 200$.
Installation	No orientation restrictions
Cavity	FC08-3 (see <i>Line Bodies & Cavities</i> section)
Cavity Tools	Rougher: 02580086 Finisher: 02580087
Cartridge Weight	0.38 Lbs. (0.17 kg)
Coil Weight	0.42 Lbs. (0.19 kg)
Cartridge Material	Steel with hardened work surfaces. Zinc-plated exposed surfaces. Buna N or Viton® o-rings, and PTFE back-up rings.
Coil Material	Class N high temperature magnet wire steel shell, polyamid encapsulation
Seal Kits	Buna-N P/N: 03054795 Viton® P/N: 02591059

Performance

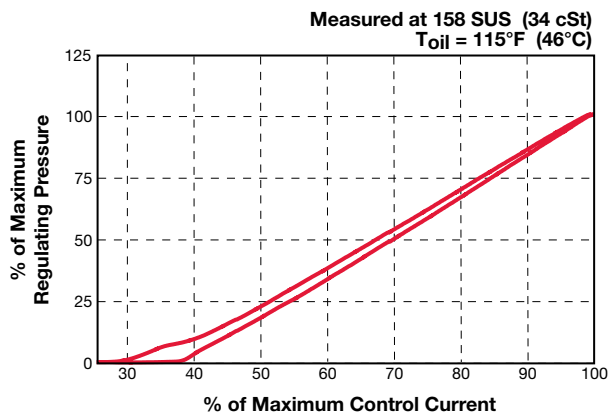

Dimensions

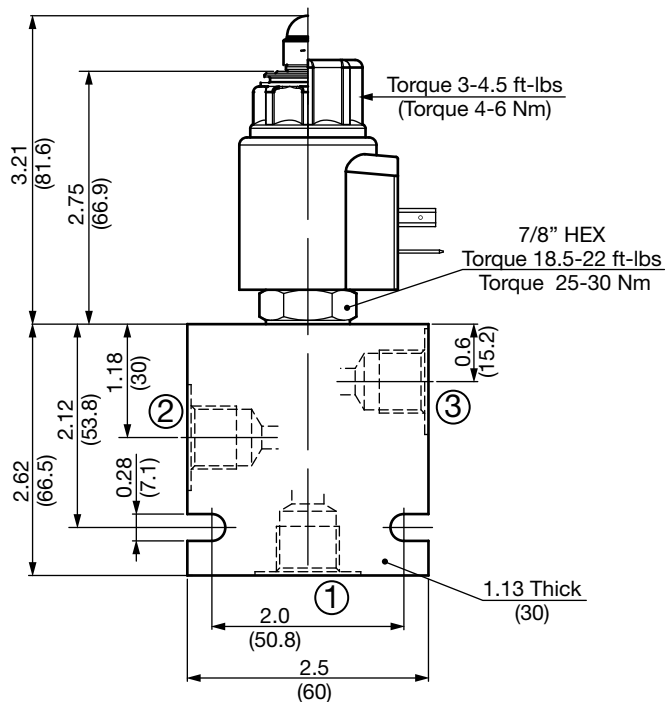

Manual Override
(Emergency pressure adjustment)
Torque 7.4-8.1 ft-lbs
(Torque 10-11 Nm)

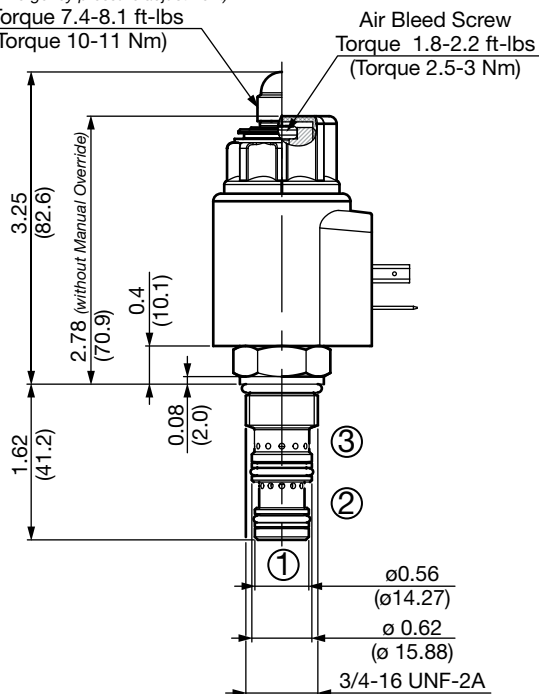

All measurements in inches (mm).
Subject to technical modifications

Standard Line Bodies*

Code	Part No	Material	Pressure Rating	Weight
FH083-AS6	03011424	Aluminum, anodized	3500 psi (245 bar)	0.58 lb (0.26 kg)
FH083-SS6	00560920	Steel, zinc plated	6000 psi (420 bar)	1.70 lb (0.77 kg)

*Please refer to Line Bodies & Cavities section for details

Model Code

PDR08-01-M-C-N-110-24 PG 8.8

Valve Model

Override Options

(omit) = No manual override
M = Manual override

Body & Ports

C = Cartridge only
AS6 = SAE-6 ports, aluminum body
SS6 = SAE-6 ports, steel body

Seals

N = Buna-N
V = Viton®

Pressure Range

20 = 0 to 200 psi (0 to 14 bar)
30 = 0 to 300 psi (0 to 20 bar)
50 = 0 to 500 psi (0 to 35 bar)
70 = 0 to 700 psi (0 to 48 bar)
110 = 0 to 1100 psi (0 to 75 bar)
200 = 0 to 2000 psi (0 to 138 bar)

Coil Voltage

0 = No coil, cartridge only
12 = 12 VDC
24 = 24 VDC

Coil Connector

PG = EN 175301-803-A
PL = Leadwires (2) - 18" long (46 cm)
PN = Deutsch™ DT04-2P, molded, axial (IP69K Rated)
PT = Amp Junior Timer™, molded, radial mount

Coil Resistance

2.2 = 2.2 Ohms (12 VDC)
8.8 = 8.8 Ohms (24 VDC)

Coil Model

P-40-1836
For other coil connector types consult factory

Performance

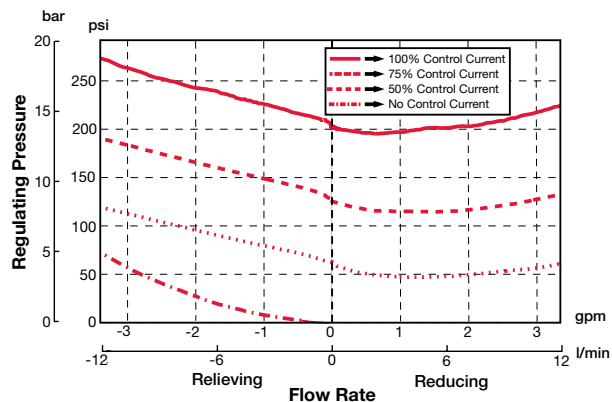
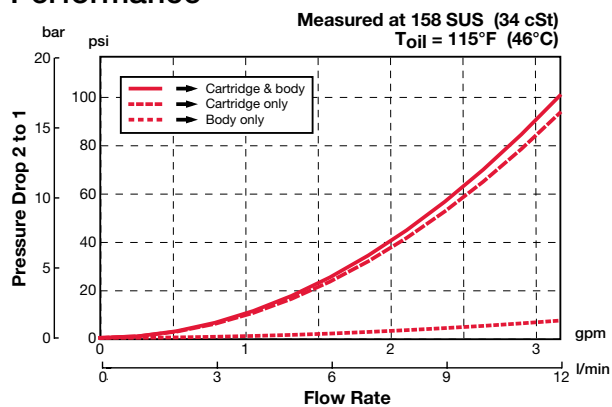

PROPORTIONAL VALVES

PDR08P-01

Pressure Reducing/Relieving Pilot Operated, Spool Type

16 gpm (60 l/min) • 5000 psi (350 bar)

Hydraulic Symbol

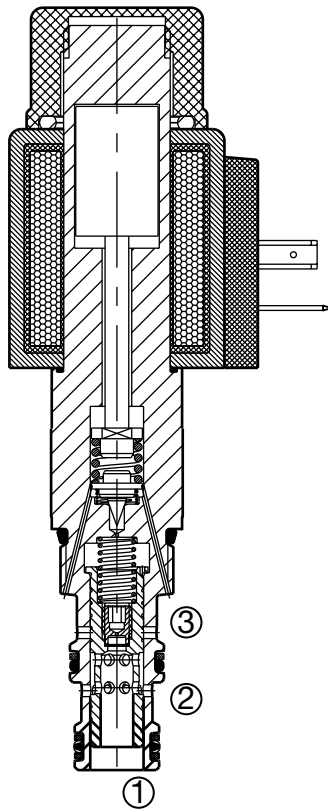
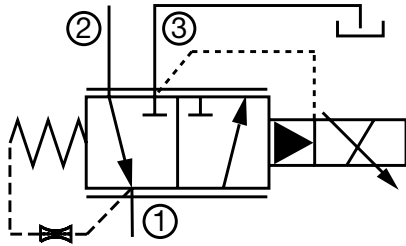

Description

A screw-in cartridge, pilot operated, spool type, pressure reducing/relieving valve, intended for use as a pressure control device, which can proportionally control the reduced pressure across the specified range using a variable electrical input signal. Reduced pressure output is proportional to DC current input. This valve maintains a constant reduced pressure regardless of pressure variations in the primary system. In addition to the reducing function, this valve also provides a relief function from the reduced pressure port to the tank port, if pressure in the secondary circuit exceeds the set pressure.

Operation

The PDR08P-01 allows flow from port 2 to port 1 until sufficient pressure is reached at port 1 to open the pilot section by offsetting the electrically induced solenoid force. Increasing electrical current will increase the control (reduced) pressure at port 1. Any pressure on port 3 is additive to the pressure setting. With no current applied to the solenoid, the valve will maintain pressure at approximately 75 psi, regardless of the pressure at port 2.

Features

- Screen on pilot orifice to enhance safety
- 12 and 24 volt proportional waterproof coils
- Manual override option

Specifications

Operating Pressure	5000 psi (350 bar) max at port 2
Nominal Flow	16 gpm (60 l/min)
Flow Path	De-energized: 1 to 2 & 2 to 1 Energized: 2 to 1; Relieving: 1 to 3
Maximum Pilot Flow	3.75 cu in/min. at 5000 psi (0.5 l/min at 350 bar)
Reducing/Relieving Pressure Ranges	75 to 870 psi (5 to 60 bar) 75 to 3300 psi (5 to 230 bar) 75 to 5500 psi (5 to 350 bar)
Maximum Control Current	2.1 amps for 12VDC coil (2.2 Ohms) 1.05 amps for 24VDC coil (8.8 Ohms)
Dither Frequency	160 to 250 Hz
Hysteresis With Dither	2-4% of maximum control current
Typical Step Response Time	ON: approx 60 ms, OFF: approx. 40 ms
Repeatability	<= 1.5% of maximum pressure range
Reversal Span	<= 2% of maximum
Response Sensitivity	<= 1% of maximum control current
Ambient Temperature Range	-4° to 140°F (-20° to 60°C)
Fluid Operating Temp. Range	-4° to 248°F (-20° to 120°C) <i>(Consult factory for usage at temp. outside range.)</i>
Fluid Compatibility	Mineral-based or synthetics with lubricating properties
Viscosity	50 to 2000 SUS (7.4 to 420 cSt)
Filtration	18/16/13 or cleaner (per ISO 4406) Use with filter rated $\beta_3 \geq 200$.
Installation	No orientation restrictions
Cavity	FC08-3 (see <i>Line Bodies & Cavities</i> section)
Cavity Tools	Rougher: 02580086 Finisher: 02580087
Cartridge Weight	0.57 Lbs. (0.26 kg)
Coil Weight	0.42 Lbs. (0.19 kg)
Cartridge Material	Steel with hardened work surfaces. Zinc-plated exposed surfaces. Buna N or Viton® o-rings, and PTFE back-up rings.
Coil Material	Class N high temperature magnet wire steel shell, polyamid encapsulation
Seal Kits	Buna-N P/N: 03054795 Viton® P/N: 02591059

Performance

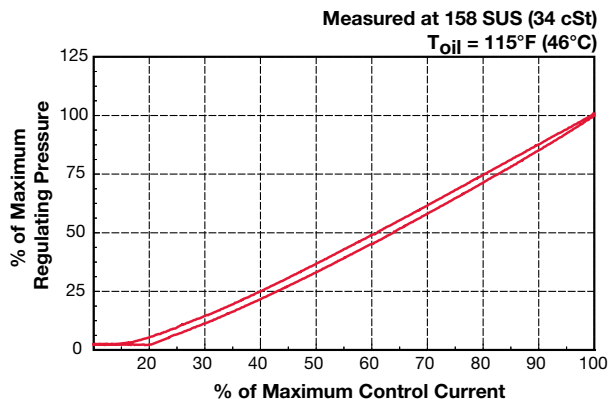

Dimensions

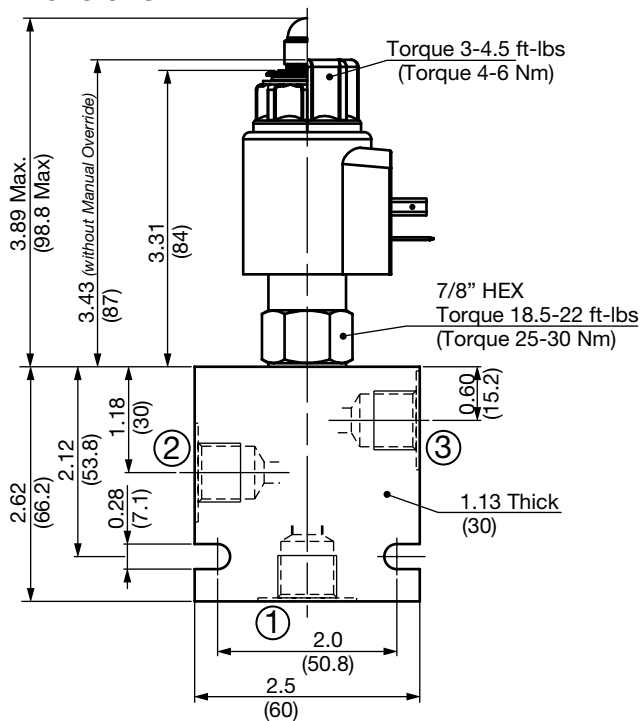

Manual Override (Emergency pressure adjustment)

Torque 7.4-8.1 ft-lbs
(Torque 10-11 Nm)

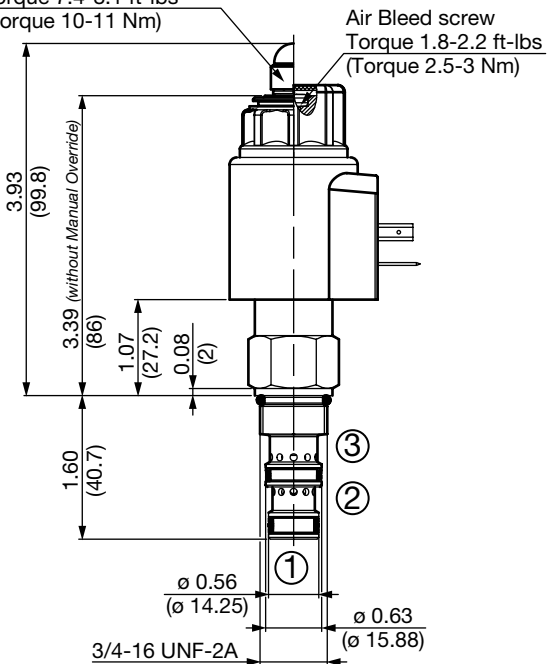

All measurements in inches (mm).
Subject to technical modifications

Standard Line Bodies*

Code	Part No	Material	Pressure Rating	Weight
FH083-AS6	03011424	Aluminum, anodized	3500 psi (245 bar)	0.58 lb (0.26 kg)
FH083-SS6	00560920	Steel, zinc plated	6000 psi (420 bar)	1.70 lb (0.77 kg)

*Please refer to Line Bodies & Cavities section for details

Model Code

PDR08P-01-M-C-N-330-24 PG 8.8

Valve Model

Override Options

(omit) = No manual override
M = Manual override

Body & Ports

C = Cartridge only
AS6 = SAE-6 ports, aluminum body
SS6 = SAE-6 ports, steel body

Seals

N = Buna-N
V = Viton®

Pressure Range

87 = 75 to 870 psi (5 to 60 bar)
330 = 75 to 3300 psi (5 to 230 bar)
500 = 75 to 5000 psi (5 to 350 bar)

Coil Voltage

0 = No coil, cartridge only
12 = 12 VDC
24 = 24 VDC

Coil Connector

PG = EN 175301-803-A
PL = Leadwires (2) - 18" long (46 cm)
PN = Deutsch™ DT04-2P, molded, axial (IP69K Rated)
PT = Amp Junior Timer™, molded, radial mount

Coil Resistance

2.2 = 2.2 Ohms (12 VDC)
8.8 = 8.8 Ohms (24 VDC)

Coil Model

P-40-1836
For other coil connector types consult factory

Performance

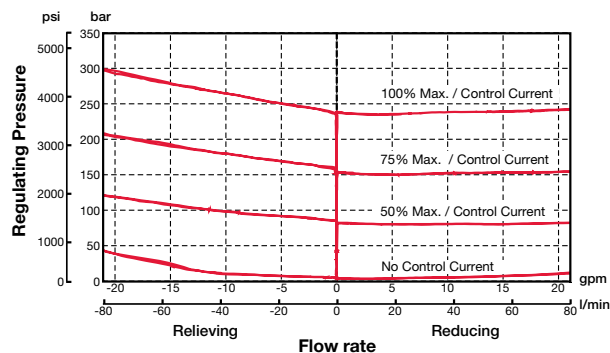
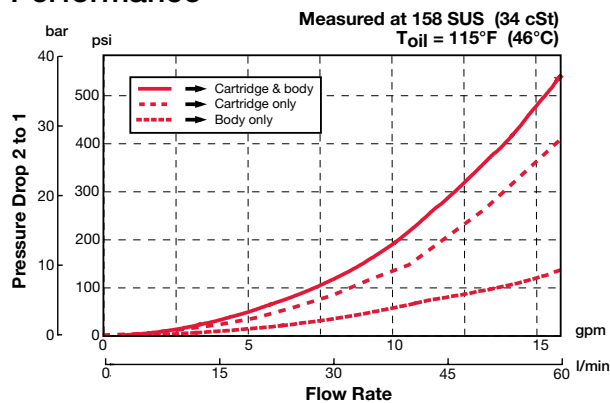

PROPORTIONAL VALVES

PDR10P-01

Pressure Reducing/Relieving, Pilot Operated, Spool Type

21 gpm (80 l/min) • 5000 psi (350 bar)

Hydraulic Symbol

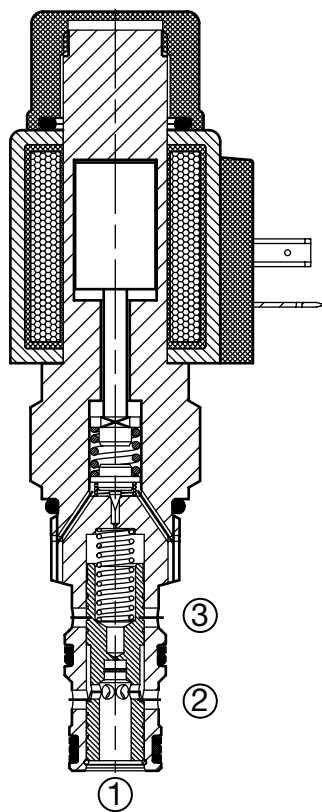
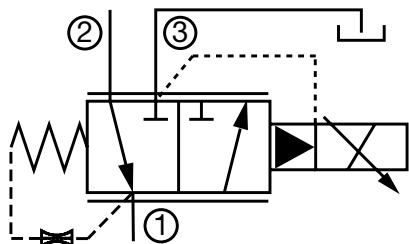

Description

A screw-in cartridge, pilot operated, spool type, pressure relieving/reducing valve, intended for use as a pressure control device, which can proportionally control the reduced pressure across the specified range using a variable electrical input signal. Reduced pressure output is proportional to DC current input. This valve maintains a constant reduced pressure regardless of pressure variations in the primary system. In addition to the reducing function, this valve also provides a relief function from the reduced pressure port to the tank port, if pressure in the secondary circuit exceeds the set pressure.

Operation

The PDR10P-01 allows flow from port 2 to port 1 until sufficient pressure is reached at port 1 to open the pilot section by offsetting the electrically induced solenoid force. Increasing electrical current will increase the control (reduced) pressure at port 1. Any pressure on port 3 is additive to the pressure setting. With no current applied to the solenoid, the valve will maintain pressure at approximately 90 psi, regardless of the pressure at port 2.

Features

- Screen on pilot orifice to enhance safety
- 12 and 24 volt proportional waterproof coils
- Manual override option

Specifications

Operating Pressure	5000 psi (350 bar) max at port 2
Nominal Flow	21 gpm (80 l/min)
Flow Path	De-energized: 1 to 2 & 2 to 1 Energized: 2 to 1; Relieving: 1 to 3
Maximum Pilot Flow	3.75 cu in/min. at 5000 psi (0.5 l/min at 350 bar)
Reducing/Relieving Pressure Ranges (0 to maximum control current)	90 to 870 psi (6 to 60 bar) 90 to 2600 psi (6 to 180 bar) 90 to 3300 psi (6 to 230 bar) 90 to 5000 psi (6 to 350 bar)
Maximum Control Current	2.1 amps for 12VDC coil (2.2 Ohms) 1.05 amps for 24VDC coil (8.8 Ohms)
Dither Frequency	160 to 250 Hz
Hysteresis With Dither	2-4% of maximum control current
Typical Step Response Time	ON: approx 60 ms, OFF: approx. 40 ms
Repeatability	<= 1.5% of maximum pressure range
Reversal Span	<= 2% of maximum
Response Sensitivity	<= 1% of maximum control current
Ambient Temperature Range	-4° to 140°F (-20° to +60°C)
Fluid Operating Temp. Range	-4° to 248°F (-20° to +120°C) (Consult factory for usage at temp. outside range.)
Fluid Compatibility	Mineral-based or synthetics with lubricating properties
Viscosity	50 to 2000 SUS (7.4 to 420 cSt)
Filtration	18/16/13 or cleaner (per ISO 4406) Use with filter rated $\beta_3 \geq 200$.
Installation	No orientation restrictions
Cavity	FC10-3 (see Line Bodies & Cavities section)
Cavity Tools	Rougher: 02580092 Finisher: 02580093
Cartridge Weight	0.57 Lbs. (0.26 kg)
Coil Weight	0.51 Lbs. (0.23 kg)
Cartridge Material	Steel with hardened work surfaces. Zinc-plated exposed surfaces. Buna N or Viton® o-rings, and PTFE back-up rings.
Coil Material	Class N high temperature magnet wire steel shell, polyamid encapsulation
Seal Kits	Buna-N P/N: 03071274 Viton® P/N: 03049443

Performance

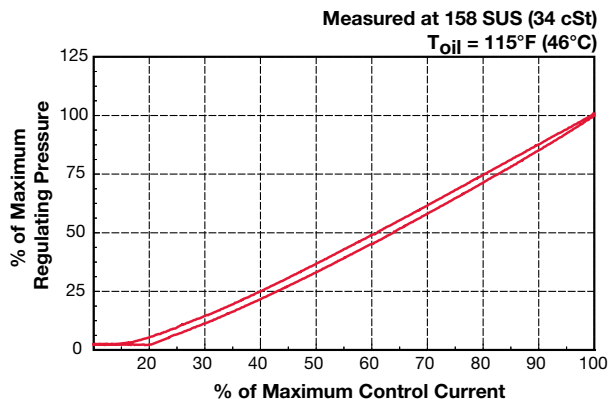

Dimensions

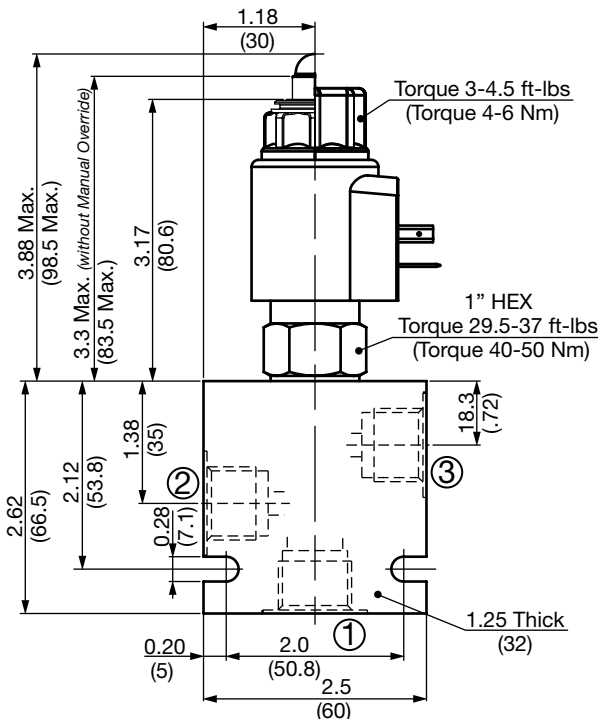

Manual Override
(Emergency pressure adjustment)
Torque 7.4-8.1 ft-lbs
(Torque 10-11 Nm)

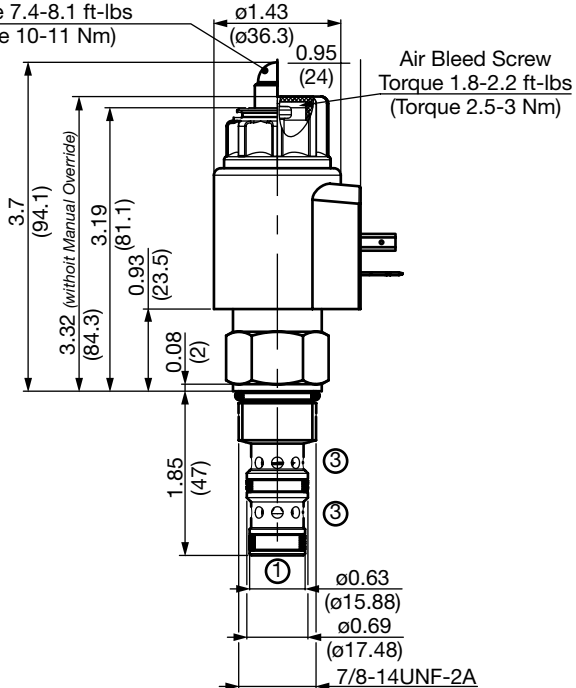

All measurements in inches (mm).
Subject to technical modifications

Standard Line Bodies*

Code	Part No	Material	Pressure Rating	Weight
FH103-AS8	03038095	Aluminum, anodized	3500 psi (245 bar)	0.60 lb (0.27 kg)
FH103-SS8	03037704	Steel, zinc plated	6000 psi (420 bar)	1.74 lb (0.79 kg)

*Please refer to Line Bodies & Cavities section for details

Model Code

PDR10P-01-M-C-N-330-24 PG 8.8

Valve Model

Override Options

- (omit) = No manual override
- M = Manual override

Body & Ports

- C = Cartridge only
- AS8 = SAE-8 ports, aluminum body
- SS8 = SAE-8 ports, steel body

Seals

- N = Buna-N
- V = Viton®

Pressure Range

- 87 = 90 to 870 psi (6 to 60 bar)
- 260 = 90 to 2600 psi (6 to 180 bar)
- 330 = 90 to 3300 psi (6 to 230 bar)
- 500 = 90 to 5000 psi (6 to 350 bar)

Coil Voltage

- 0 = No coil, cartridge only
- 12 = 12 VDC
- 24 = 24 VDC

Coil Connector

- PG = EN 175301-803-A
- PL = Leadwires (2) - 18" long (46 cm)
- PN = Deutsch™ DT04-2P, molded, axial (IP69K Rated)
- PT = Amp Junior Timer™, molded, radial mount

Coil Resistance

- 2.2 = 2.2 Ohms (12 VDC)
- 8.8 = 8.8 Ohms (24 VDC)

Coil Model

P-40-1836
For other coil connector types consult factory

Performance

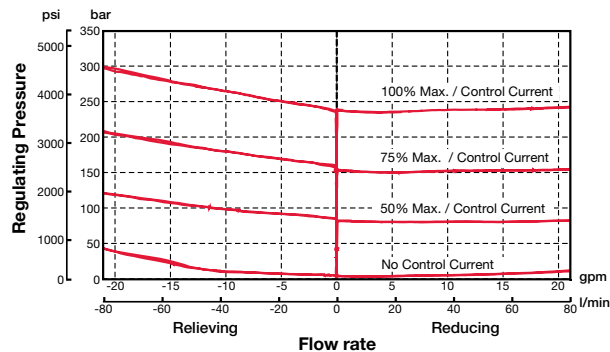
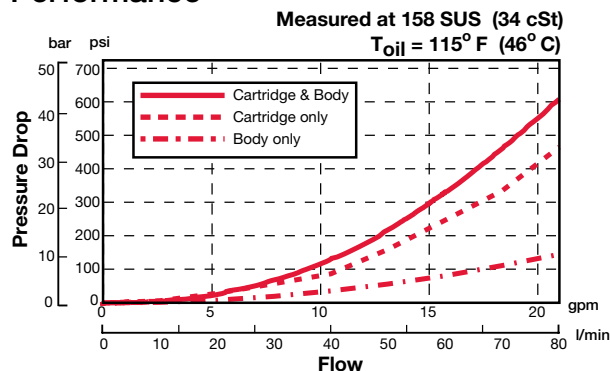

PROPORTIONAL VALVES

Notes

A large grid for taking notes, consisting of 20 columns and 40 rows. The grid is empty and occupies most of the page.

1 Overview

HYDAC offers two types of the Hand Pump valves.

- MP10-01 screw in cartridge valve, push type
- MP10-02 screw in cartridge valve, push type with the collar to bolt mount to the block for orientation

Features

- Built in suction and outlet checks provide for compact device in one cavity
- Heavy duty construction
- Handle rotates 360 deg
- All external cartridge surfaces zinc plated to resist corrosion
- Industry common cavity

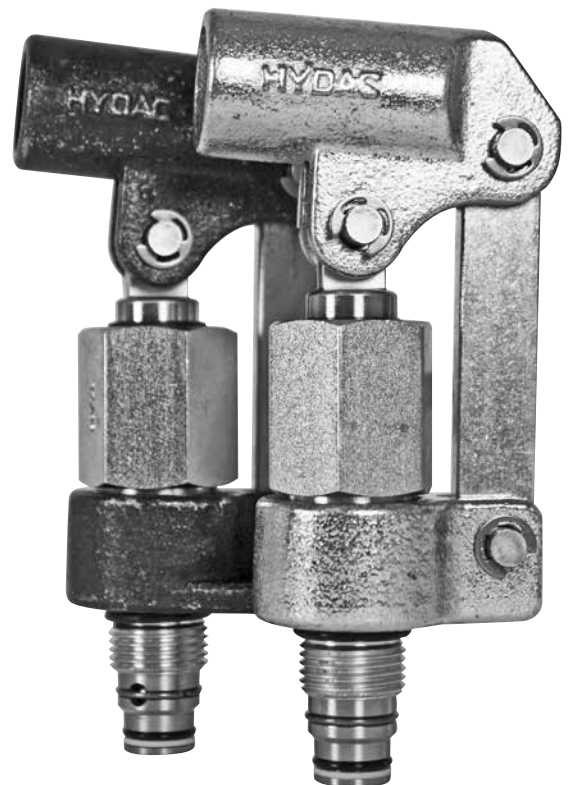

HAND PUMPS

MP10-01

Push Type

3000 psi (207 bar)

Hydraulic Symbol

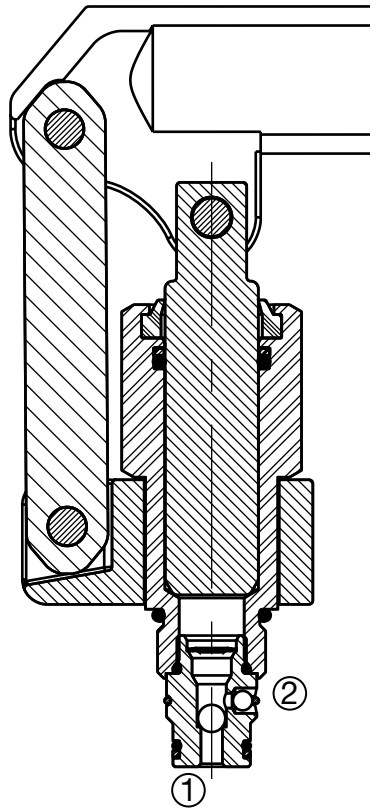
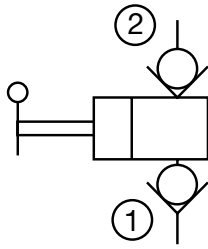

Description

A screw-in cartridge, push type hand pump with two built-in check valves

Operation

The MP10-01 provides hydraulic flow up to 0.45 cu. in. (7.5 cc) per stroke, at 3000 psi (207 bar). Internal suction and outlet checks provide a compact device. See performance Chart for handle torque requirements.

Features

- Hardened parts for long life
- Heavy duty construction
- Handle rotates 350°
- Push linkage standard
- All external surfaces zinc-plated
- Industry common cavity
- Handle socket sized for 1/2" (0.840 O.D.) pipe
- Arc angle 45°

Specifications

Operating Pressure	3000 psi (207 bar)		
Nominal Flow per 45° Stroke	0.46 cubic inches (7.5cc)		
Leakage	5 drops per minute (<i>Outlet Check</i>)		
Suction Pressure	11 in. Hg (5.4 psi) less than atmospheric pressure		
Fluid Operating Temp. Range	-20° to 248°F (-29° to 120°C)		
Fluid Compatibility	Mineral-based or synthetics with lubricating properties		
Viscosity	50 to 2000 SUS (7.4 to 420 cSt)		
Filtration	21/19/16 or cleaner per (ISO 4406)		
Installation	No orientation restrictions		
Cavity	FC10-2 (<i>see Line Bodies & Cavities section</i>)		
Cavity Tools	Rougher: 02580274 Finisher: 02580247		
Cartridge Weight	1.75 lbs (0.80 kg)		
Cartridge Material	Steel with hardened work surfaces. Zinc plated exposed surfaces. Buna N or Viton® o-rings. Solid thermoplastic polyester back-up rings.		
Seal Kits	Buna-N	FS102-N	P/N: 03033872
	Viton®	FS102-V	P/N: 03051757

Performance

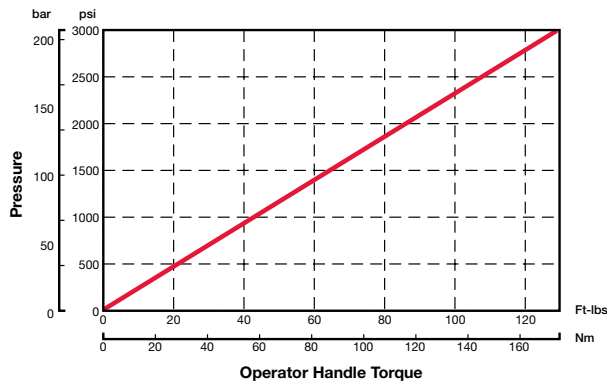

Dimensions

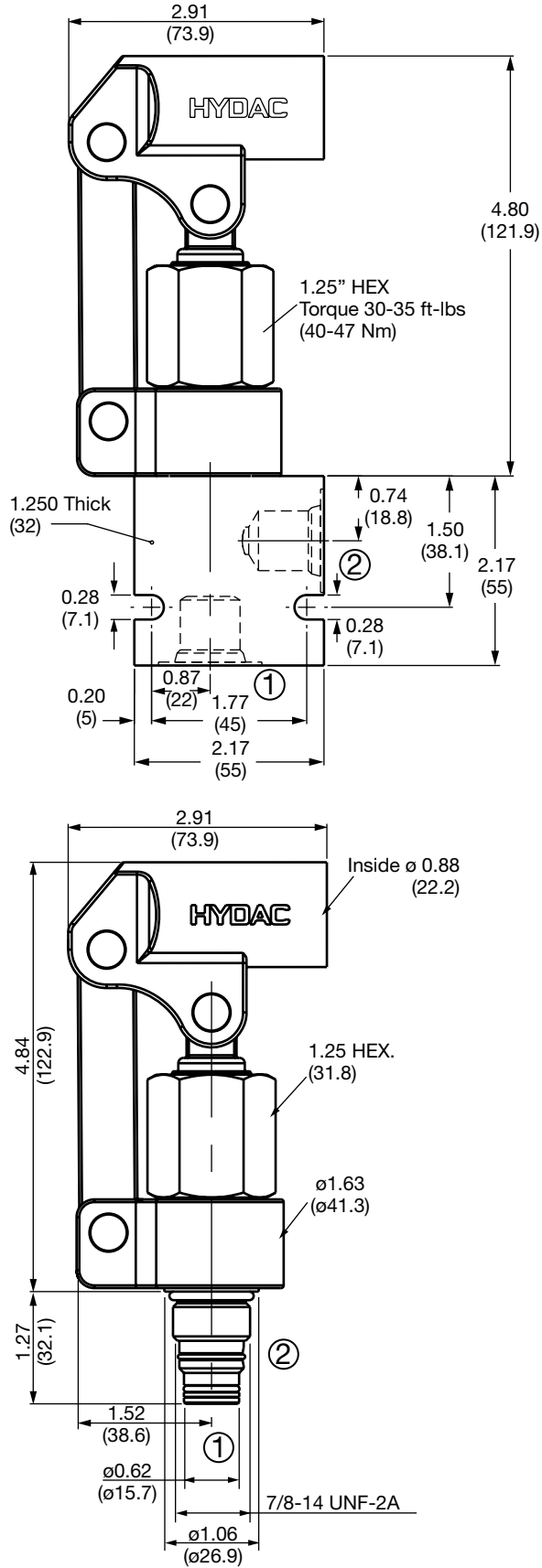

Model Code

MP10-01-AS8-N

Valve Model _____

Body & Ports _____

- C = Cartridge only
- AS8 = SAE-8 ports, aluminum body
- SS8 = SAE-8 ports, steel body

Seals _____

- N = Buna-N
- V = Viton™

All measurements in inches (mm).
Subject to technical modifications

PN#02087369 / 10.19 / CHD1110-1389

Standard Line Bodies*

Code	Part No	Material	Pressure Rating	Weight
FH102-AS8	03037778	Aluminum, anodized	3500 psi (245 bar)	0.40 lb (0.18 kg)
FH102-SS8	03037612	Steel, zinc plated	6000 psi (420 bar)	1.16 lb (0.53 kg)

*Please refer to Line Bodies & Cavities section for details

HAND PUMPS

MP10-02

Push Type

3000 psi (207 bar)

Hydraulic Symbol

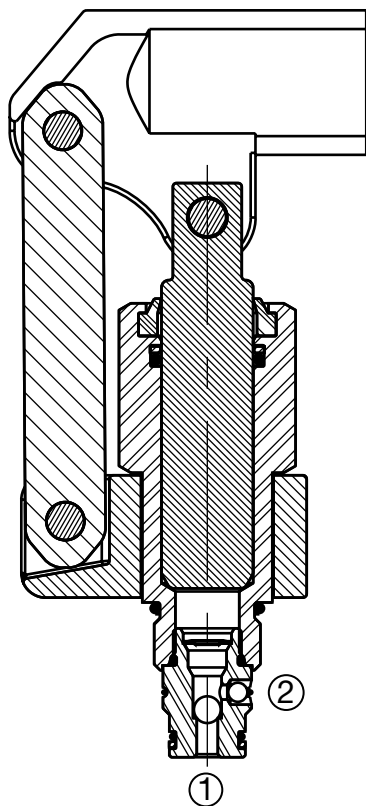
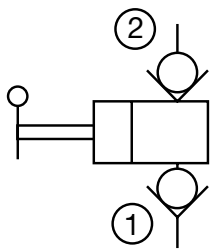

Description

A screw-in cartridge, push type hand pump with two built-in check valves

Operation

The MP10-02 provides hydraulic flow up to 0.45 cu. in. (7.5 cc) per stroke, at 3000 psi (207 bar). Internal suction and outlet checks provide a compact device. See performance Chart for handle torque requirements.

Features

- Hardened parts for long life
- Heavy duty construction
- Handle rotates 360° and can be fixed
- Push linkage standard
- Optional collar to bolt mount to the block for orientation
- All external surfaces zinc-plated
- Industry common cavity
- Arc angle 45°
- Handle socket sized for 1/2" (0.840 O.D.) pipe

Specifications

Operating Pressure	3000 psi (207 bar)	
Nominal Flow per 45° Stroke	0.46 cubic inches (7.5cc)	
Leakage	5 drops per minute (<i>Outlet Check</i>)	
Suction Pressure	11 in. Hg (5.4 psi) less than atmospheric pressure	
Fluid Operating Temp. Range	-20° to 248°F (-29° to 120°C)	
Fluid Compatibility	Mineral-based or synthetics with lubricating properties	
Viscosity	50 to 2000 SUS (7.4 to 420 cSt)	
Filtration	21/19/16 or cleaner per (ISO 4406)	
Installation	No orientation restrictions	
Cavity	FC10-2 (<i>see Line Bodies & Cavities section</i>)	
Cavity Tools	Rougher:	02580274
	Finisher:	02580247
Cartridge Weight	1.80 lbs (0.82 kg)	
Cartridge Material	Steel with hardened work surfaces. Zinc plated exposed surfaces. Buna N or Viton® o-rings. Solid thermoplastic polyester back-up rings.	
Seal Kits	Buna-N	FS102-N P/N: 03033872
	Viton®	FS102-V P/N: 03051757

Performance

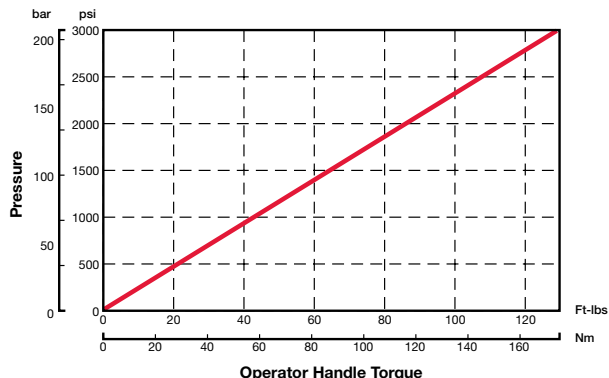

Dimensions

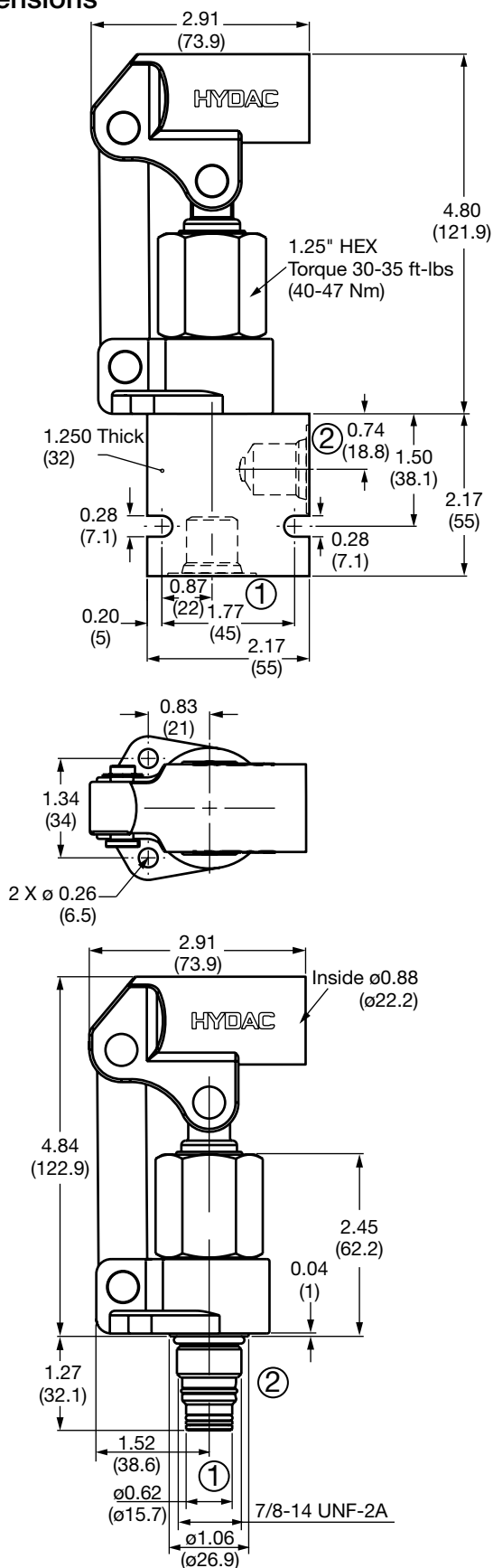

Model Code

MP10-02-AS8-N

Valve Model _____

Body & Ports _____

- C = Cartridge only
- AS8 = SAE-8 ports, aluminum body
- SS8 = SAE-8 ports, steel body

Seals _____

- N = Buna-N
- V = Viton™

All measurements in inches (mm).
*Subject to technical modifications

Standard Line Bodies*

Code	Part No	Material	Pressure Rating	Weight
FH102-AS8	03037778	Aluminum, anodized	3500 psi (245 bar)	0.40 lb (0.18 kg)
FH102-SS8	03037612	Steel, zinc plated	6000 psi (420 bar)	1.16 lb (0.53 kg)

*Please refer to Line Bodies & Cavities section for details

HAND PUMPS

Notes

A large grid of graph paper, consisting of 24 columns and 34 rows, intended for taking notes.



J1

Features and Benefits

Maximum Power - Minimum Space

Perfectly layered wound coil packs more copper into smaller space. Perfect winding eliminates crossed wires and the potential for short-circuits. More copper windings ensure maximum solenoid force per current input.

Continuous High Temperature Operation

All HYDAC coils use high quality 'Class N' wire to ensure that coils can be continuously operated in extreme high temperatures and over-voltage without failure.

Resistance to Thermal Shock

HYDAC coils have passed what are commonly referred to as 'thermal shock dunk tests'. This involves heating the coil to an extreme temperature for a period of time, then immersing in very cold salt water. The cycle is repeated and coil operation checked for signs of degradation.

All Weather Resistant

Encapsulated and internally sealed, the rugged steel shell construction prevents ingress of water. HYDAC coils have passed numerous 'salt-spray tests'. No external sealing or waterproofing kits are needed.

IP Rated

HYDAC coils are rated from IP65 to IP69K. The quality of connector selected determines the IP rating. Deutsch DT04-2P achieves IP69K, while a DIN 43650 interface achieves IP65.

Physically Robust

Thick steel shell protects coil from physical damage. Zinc plating protects the shell from corrosion.

Coils are DC wound

All HYDAC coils are DC wound. AC designated coils from size 8, 10, 12, and 16 valves are internally full wave rectified. This results in a more reliable coil since inrush cycles are eliminated. There is no 'buzz' or 'hum' normally associated with 'true AC' coils. AC coils can operate on 50-60Hz supply. DC and AC coils are fully interchangeable. Coils for size 6 cartridges do not have built-in rectifiers and require external rectifications of the AC signals.

Suppression Diodes

DC coils are available with an internal, bi-directional, transient voltage suppression diode. This can help protect the end users control circuit from induction voltages. Using a bi-directional diode means the coil is not polarity sensitive.

Symmetric Coil Construction

HYDAC coils can be installed face up or face down on the valve with no reduction in performance.

Note: UL 583 listed coils available. Consult factory.

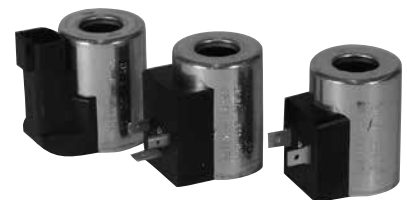

SOLENOID COILS

Solenoid Coils - Size 8, 10, 12 & 16 Cartridges Valves

Coil Materials

Class N high temperature magnetwire (200°C). Zinc plated steel shell. Polyamide encapsulation, black.

Coil Information

- Special voltages and terminations are available for OEM applications; consult factory
- AC service coils are internally rectified and can be used in 50 Hz or 60 Hz power lines. The rectifiers used in these coils may require protection from high voltage surges in some electrical circuits containing highly inductive or capacitive components. These include certain types of motors, solenoids, relays and transformers.
- AC voltage transient surges over 600 volts may require a voltage surge suppressor (MOV varistor) to be placed in parallel to the coil, as shown on the surge suppressor circuit diagram below.

Coil Accessories: DIN Plug

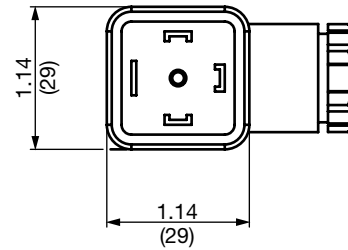
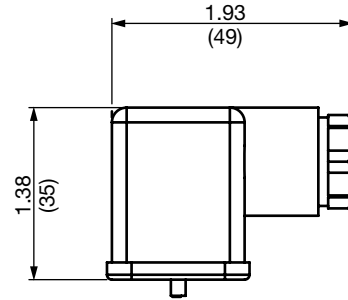

Voltage	Suggested Varistor Part No.*	Joule Rating
115	150LA10A	45
230	250LA40A	130

*Available from electronics supplier

AC Voltage Diode Bridge Rectification Circuit Diagram

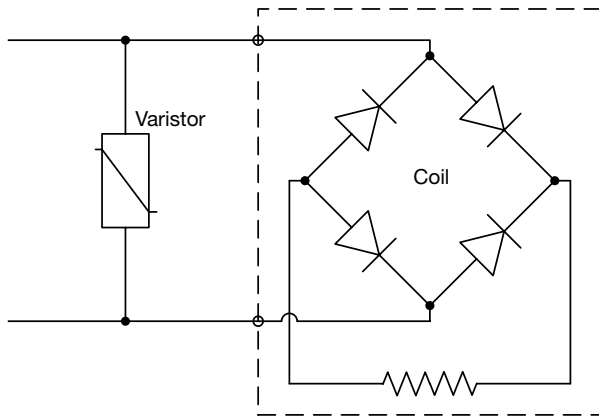

EN 175301-803-A
Part Number: 00394287
 All measurements in inches (mm).

DC Coils Transient Voltage Suppressor Bi-directional Diode (optional) Diagram

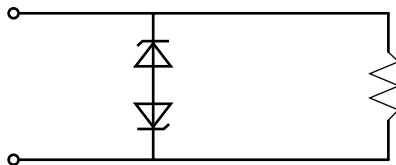

- Bi-directional suppression diode protects coil winding from induction voltages

Quick Reference

Coils suitable for Valve Models

Coils Type 40-1836 and 50-1836

Poppet Valves

COIL 40-1836	COIL 50-1836
WS08Z-01	WS10W-01
WS08Z-01J	
WS08Z-30	
WS08ZR-01	
WS08ZR-01J	
WS08ZR-30	
WS081Z-01	
WS081ZR-01	
WS10Z-01	
WS10ZR-01	
WS12Z-01	
WS12ZR-01	
WS16Z-01	
WS16ZR-01	
WS08Y-01	
WS08Y-30	
WS08YR-01	
WS08YR-30	
WS081Y-01	
WS081YR-01	
WS10Y-01	
WS10YR-01	
WS12Y-01	
WS12YR-01	
WS16Y-01	
WS16YR-01	
WS08W-01	
WS08W-30	
WS08D-51	
WS08V-01	

Spool Valves

COIL 40-1836	COIL 50-1836
WK08W-01	WK10W-01
WK081W-01	WK10V-01
WK08V-01	WK10L-01
WK081V-01	WK10C-01
WK07L-01	WK10D-01
WK08L-01	WK10Y-01
WK08C-01	WK10X-01
WK08D-01	WK10A-01
WK08Y-01	WK10Z-01
WK08X-01	WK10K-01
WK08A-01	WK10N-01
WK08Z-01	WK10P-01
WK08K-01	WK10R-01
WK08P-01	
WK08R-01	
WK08E-01	
WK08J-01	
WK10E-01	
WK10G-01	
WK10H-01	
WK10J-01	
WK10T-01	

Coils Type P40-1836 and P50-1836

Proportional Valves

COIL P40-1836	COIL P50-1836
PDR08-01	PDR08-11
PDR08P-01	PDR08-20
PDR10P-01	PDR08-50
PDB08P-01	
PDB10P-01	
PDB12P-01	
PDB16P-01	

SOLENOID COILS

Type 40-1836 (40 mm height) Rating & Specifications

Solenoid Coils Ratings

Duty rating	Continuous from 85% to 115% of nominal voltage
Max Coil Temperature	320°F (160°C)
Power Rating	18 watts @ nominal voltage
Encapsulant	Polyamide, black
Magnet Wire	U.L. class H, 353°F (180°C)
Coil Shell	Steel, Zinc plated
Transient Voltage Suppressor Diode for DC coils	Bi-directional, maximum clamping voltage - 68 volts

Solenoid Coils Winding Specifications

Nominal Voltage (V)	Resistance at 20°C (Ω)	Nominal Current (A)
10 VDC	5.4	1.85
12 VDC	8	1.5
24 VDC	30	0.8
36 VDC	65	0.55
48 VDC	116	0.41
110 VAC	607	0.18
24 VAC	24.8	0.85
115 VAC	500	0.2
230 VAC	2137	0.096

Connectors & Part Numbers (Commonly used)

Voltage	Connector Type					
	DIN G	Dual Spade S	Leadwires L	Weather Pack W	Deutsch N	Amp Jr Timer T
10VDC	3003128	3013042	3003135	3003131	3012601	3008291
12VDC	3000489	3000973*	3002244*	3003124*	3012600*	3008275*
24VDC	3000249	3000247*	3003119*	3003088*	3012599*	3008279*
36VDC	3003151	3003043*	3003140*	3003144*	3012602*	3008283*
48VDC	3003155	3013044*	3003149*	3003147*	3012603*	3008287*
110VDC	3003142					
24VAC	3003122					
115VAC	3003156					
230VAC	3002594					

*Diode version available, contact your HYDAC representative.

For other voltages and connectors contact your HYDAC representative.

Type 50-1836 (50 mm height) Rating & Specifications

Solenoid Coils Ratings

Duty rating	Continuous from 85% to 115% of nominal voltage
Max Coil Temperature	320°F (160°C)
Power Rating	27 watts @ nominal voltage
Encapsulant	Polyamide, black
Magnet Wire	U.L. class H, 353°F (180°C)
Coil Shell	Steel, Zinc plated
Transient Voltage Suppressor Diode for DC coils	Bi-directional, maximum clamping voltage - 68 volts

Solenoid Coils Winding Specifications

Nominal Voltage (V)	Resistance at 20°C (Ω)	Nominal Current (A)
10 VDC	3.7	2.7
12 VDC	5.4	2.22
24 VDC	21.2	1.13
36 VDC	48	0.75
48 VDC	86	0.56
110 VAC	440	0.25
24 VAC	18	1.33
115 VAC	363	0.3
230 VAC	1680	0.14

Connectors & Part Numbers (Commonly used)

Voltage	Connector Type					
	DIN G	Dual Spade S	Leadwires L	Weather Pack W	Deutsch N	Amp Jr Timer T
10VDC	3091543	3091594	3003135	3091646	3091664*	3091640
12VDC	915151	3002163*	3091633	3013032*	3091665*	3001033*
24VDC	915142	3002151*	3003119	3091658*	3091667*	3001503*
36VDC	3091590	3091629	3003140	3091661	3091669*	3091642
48VDC	3091591	3091631	3003149	3091662	3091670*	3001507
110VDC	3091592					
24VDC	3091593					
115VAC	3019735					
230VAC	3019736					

*Diode version available, contact your HYDAC representative.
For other voltages and connectors contact your HYDAC representative.

SOLENOID COILS

Type P40-1836 & P50-1836 Rating & Specifications

Proportional Coils Ratings

Duty rating	Continuous
Max Coil Temperature	320°F (160°C)
Encapsulant	Polyamide, black
Magnet Wire	U.L. class H, 353°F (180°C)
Coil Shell	Steel, Zinc plated

Proportional Coils Winding Specifications

Nominal Voltage (V)	Resistance at 20°C (Ω)	Nominal Current (A)
12 VDC Type 40	2.20	2.1
24 VDC Type 40	8.80	1.05
12 VDC Type 50	4.10	1.75
24 VDC Type 50	18.00	0.85

Connectors & Part Numbers (Commonly used)

Voltage/Type	Connector Type			
	DIN G	Leadwires L	Deutsch N	Amp Jr Timer T
12VDC TYPE 40	3109230	3109947	3110056	3162388
24VDC TYPE 40	3109229	3110048	3110057	3162390
12VDC TYPE 50	3179976	3179980	3179990	3120939
24VDC TYPE 50	3179953	3179985	3179991	3120938

Coil Type 40 Dimensions

AG-DG-40-1836
PG-40-1836

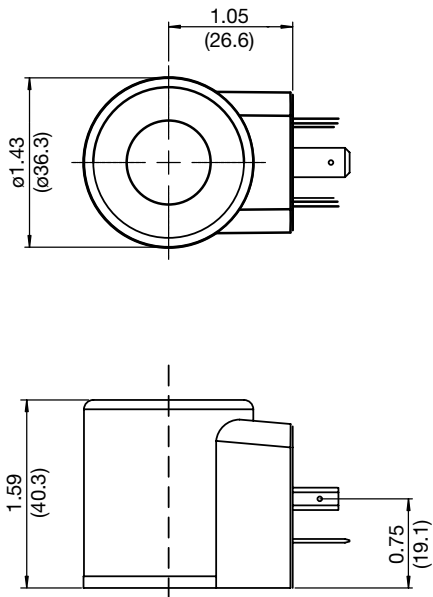

Din 175301

DL-40-1836
PL-40-1836

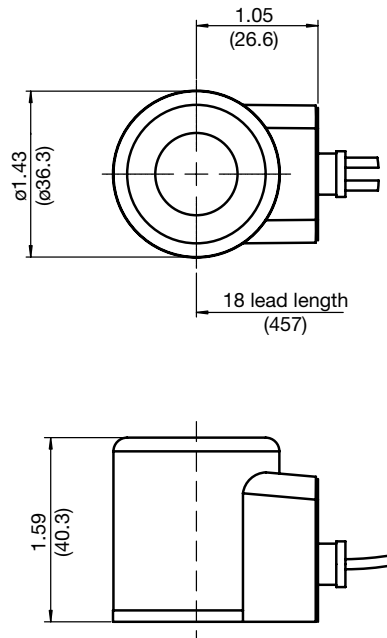

Dual Leads

DN-40-1836
PN-40-1836

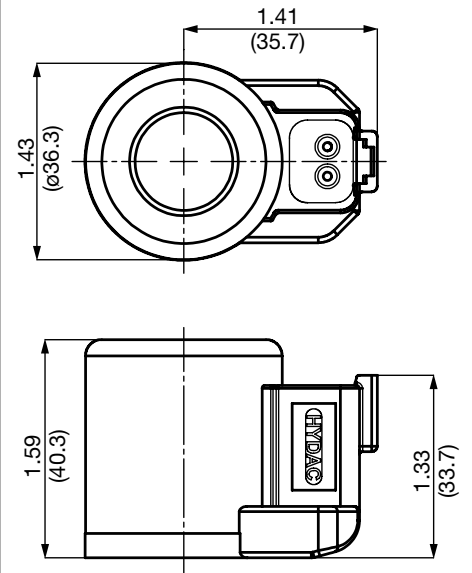

Deutsch™ DT04-2p

DS-40-1836

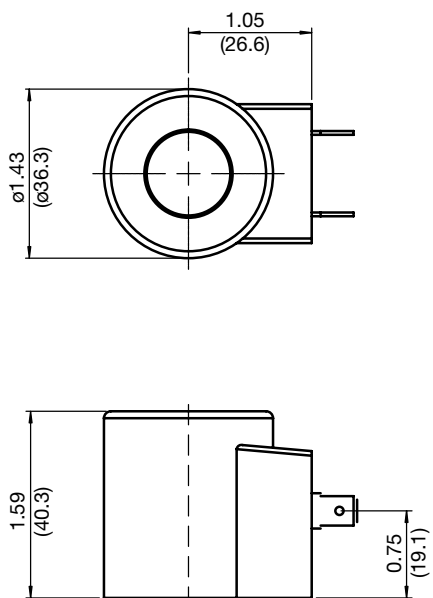

Dual 1/4" Spades

DT-40-1836
PT-40-1836

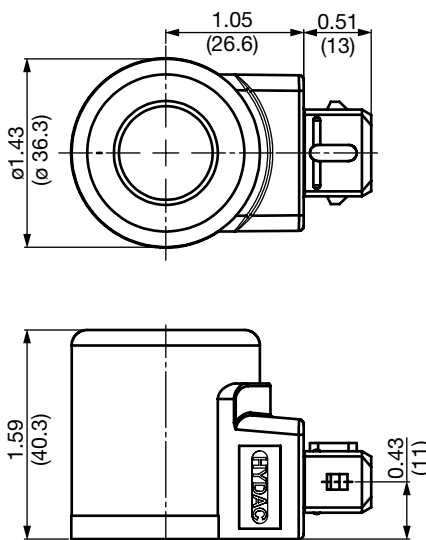

Amp Jr. Timer™

DW-40-1836

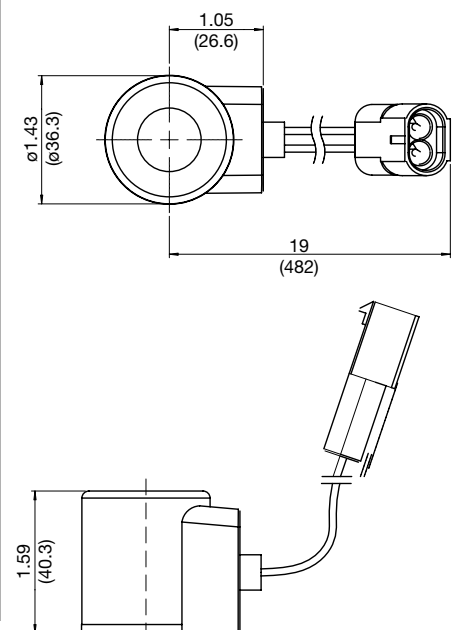

WeatherPak™ 12010973

All measurements in inches (mm).

SOLENOID COILS

Coil Type 50 Dimensions

AG-DG-50-1836
PG-50-1836

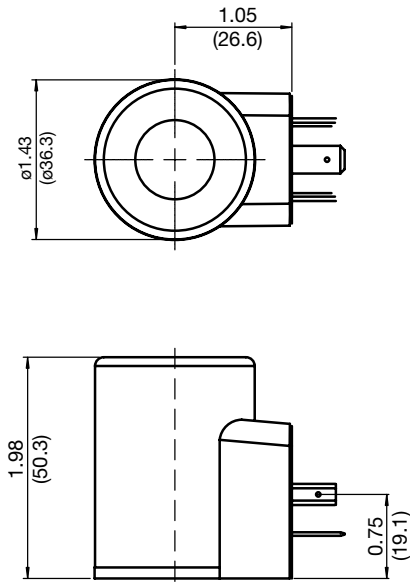

Din 175301

DL-50-1836
PL-50-1836

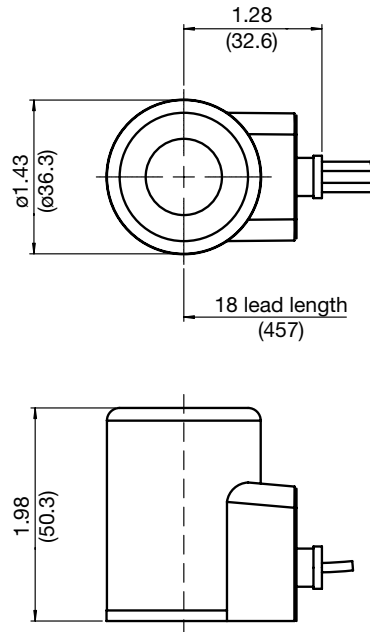

Dual Leads

DN-50-1836
PN-50-1836

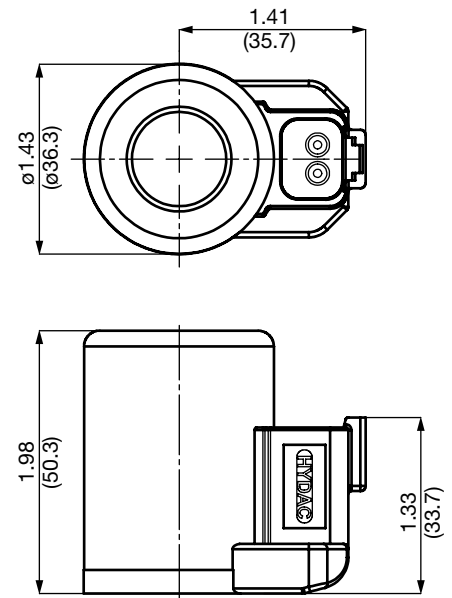

Deutsch™ DT04-2p

DS-50-1836

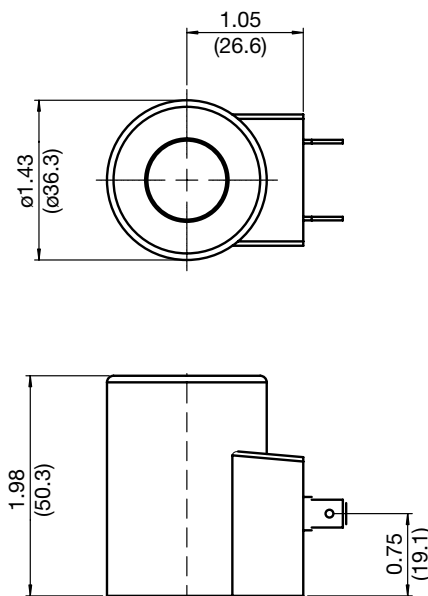

Dual 1/4" Spades

DT-50-1836
PT-50-1836

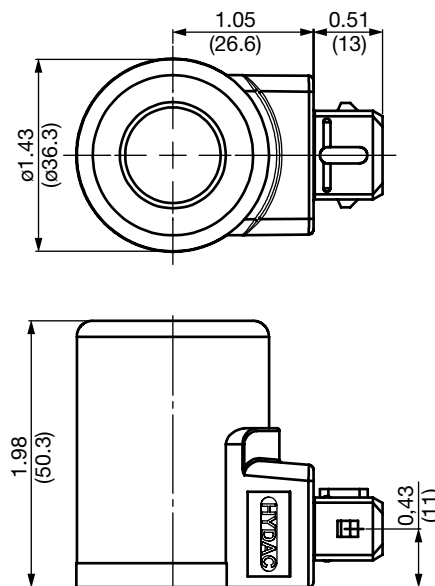

Amp Jr. Timer™

DW-50-1836

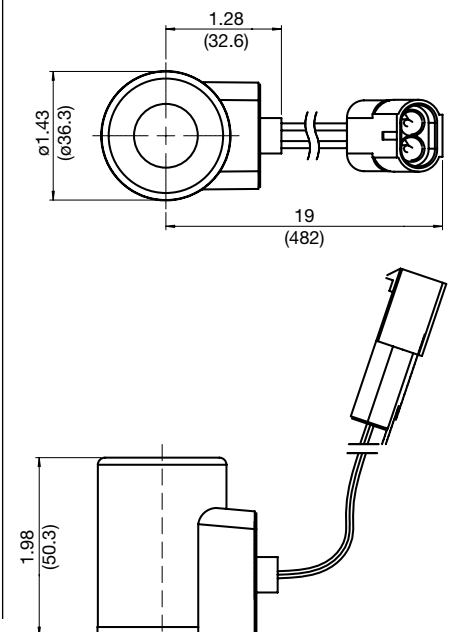

WeatherPak™ 12010973

All measurements in inches (mm).

Solenoid Coils - Size 6 Cartridges Valves

Type 32-1329 (32 mm height) Rating & Specifications

Solenoid Coils Ratings

Duty rating	Continuous from 85% to 115% of nominal voltage
Max Coil Temperature	320°F (160°C)
Power Rating	12 Watts @ Nominal Voltage
Encapsulant	Thermoplastic, Black
Magnet Wire	U.L. Class N, 392°F (200°C)
Coil Shell	Steel, Zinc plated
Transient Voltage Suppressor Diode for DC coils*	Bi-directional, maximum clamping voltage- 68 volts

Solenoid Coils Winding Specifications

Nominal Voltage (V)	Resistance at 20°C (Ω)	Nominal Current (A)
12 VDC	12.2	0.98
24 VDC	48.7	0.49
105 VDC	980	0.11
205 VDC	3700	0.06

Connectors & Part Numbers (Commonly used)

Nominal Voltage (V)	Connector Type			
	DIN DG	Leadwires DL	Weather-Pack DW	Deutsch DN
12 VDC	02610160*	02610151*	02610287*	02610149*
24 VDC	02610161*	02610162*	02610288*	02610150*
105 VDC	02610156	Not Available	Not Available	Not Available
205 VDC	02610159	Not Available	Not Available	Not Available
120 VAC	Coil 02610156 & Plug 02600582			
230 VAC	Coil 02610159 & Plug 02600582			

*Diode version available, contact your HYDAC representative.
 For other voltages and connectors contact your HYDAC representative
 All coil for DC coils; for AC voltage use rectifier plugs.
Note: UL 583 listed coils available. Consult factory.

Coil Accessories: DIN Plugs

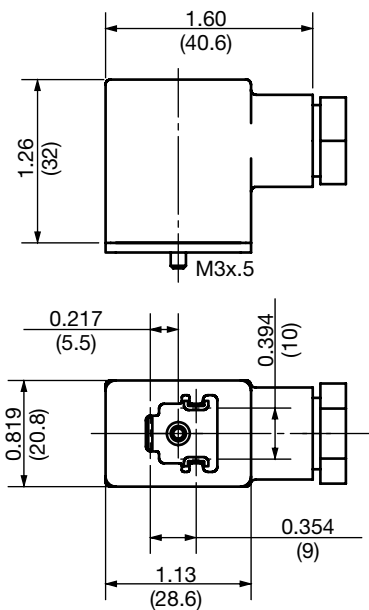

Circuit Diagram: Rectifier Plug

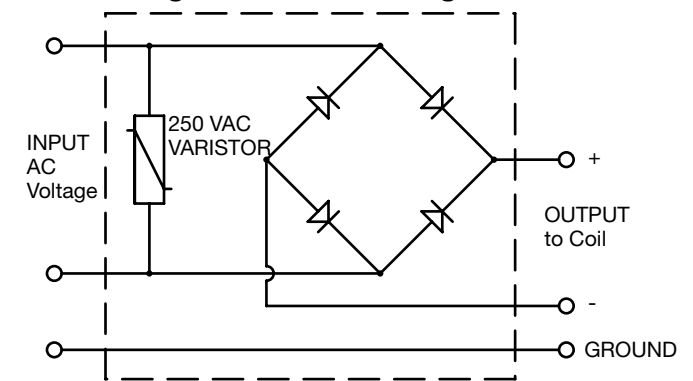

Part Number: 02600582

Type: EN 175301-803-B
Part Number: 02600570 - without diode bridge; use with DC Coils
Part Number: 02600582 - with diode bridge; use for applying AC input to DC coils

All measurements in inches (mm).

SOLENOID COILS

Coil Type 32 Dimensions

DN-32-1329

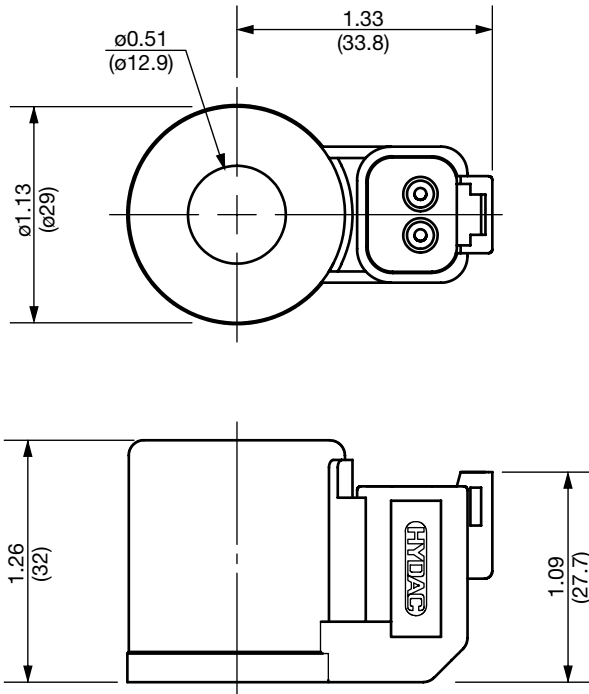

Deutsch™ DT04-2p

DL-32-1329

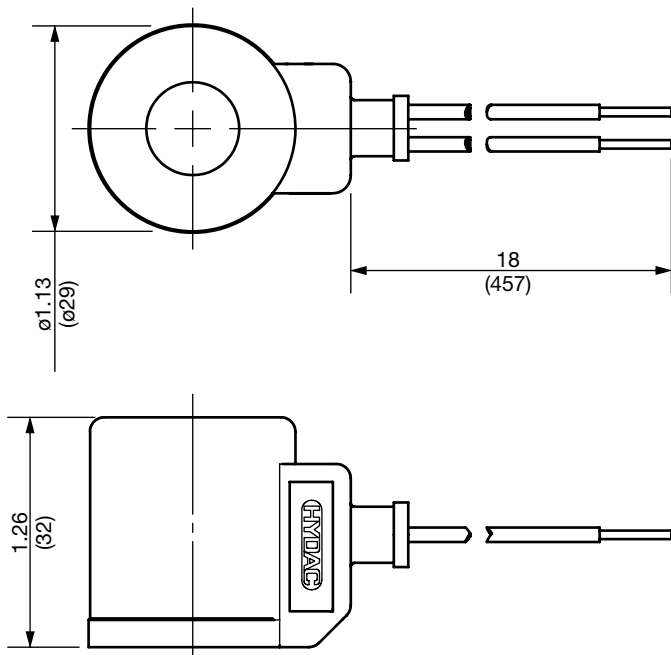

Dual Leads

DG-32-1329

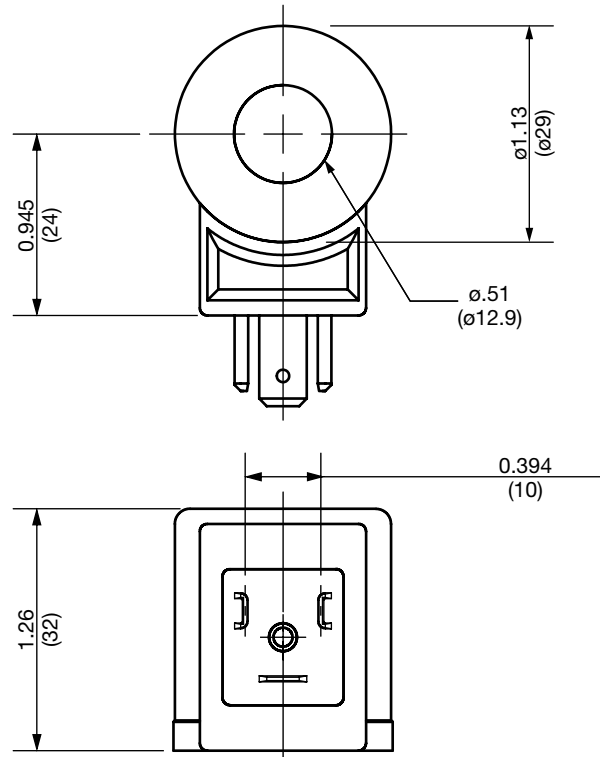

DIN 43650 Form B

All measurements in inches (mm).

K1

Overview

Description

As important as the performance of the valve itself is the proper installation of the cartridge into a correctly made manifold or body. HYDAC's full range of cartridge valves can be used in custom manifold applications, or for in-line installation via our selection of cartridge line bodies. These next few pages provide the detail required for designers, machine shops or users to create successful HYDAC cartridge valve installations. Whether using form tools to make a custom manifold, or quickly plumbing a valve and line body assembly, the HYDAC cartridge cavity system enables versatile and reliable valve applications. Performance and dimensional information for a specific valve can be found on individual cartridge data sheets.

Cavities

Cavity drawings are provided as a tool for HYDAC customers who desire to produce their own custom manifolds. Manufacturing to the drawings enclosed ensures correct cavity fit and proper cartridge function at maximum performance limits.

Line Bodies

HYDAC line bodies provide a cost effective method for compact, easy installation of any HYDAC cartridge. Using authentic HYDAC bodies - with each cavity and port machined to our own exacting standards - ensures safe, high-performance function of cartridge valves plumbed "in-line."

Standard line bodies are available for each cavity size in both clear anodized aluminum (3500 psi max. pressure) or clear zinc-plated steel (6000 psi max. pressure) are offered with SAE O-ring boss ports. When ordering alternate port configurations, please contact the factory.



LINE BODIES & CAVITIES

Model Code

FH 082 - A S 6

SERIES					
FH	=	Line Body			
CAVITY					
062	=	FC06-2			
063	=	FC06-3			
064	=	FC06-4			
082	=	FC08-2			
083	=	FC08-3			
084	=	FC08-4			
102	=	FC10-2			
103	=	FC10-3			
10S3	=	FC10-S3			
104	=	FC10-4			
122	=	FC12-2			
123	=	FC12-3			
124	=	FC12-4			
162	=	FC16-2			
163	=	FC16-3			
16S3	=	FC16-S3			
164	=	FC16-4			
M455	=	FCM45-5			
MATERIAL					
A	=	Anodized Aluminum			
S	=	Zinc Plated Steel			
THREAD					
N	=	NPT			
S	=	SAE			
B	=	BSPP			

PORT SIZE					
2	=	1/4" NPT			
4	=	SAE-4 (7/16-20 UNF) (standard for size 06 only)			
2	=	BSPP G1/4			
3	=	3/8" NPT			
6	=	SAE-6 (9/16-18 UNF) (standard for size 08 only)			
3	=	BSPP G3/8			
4	=	1/2" NPT			
8	=	SAE-8 (3/4-16 UNF) (standard for size 10 only)			
4	=	BSPP G1/2			
6	=	3/4" NPT			
12	=	SAE-12 (1-1/16-12) (standard for size 12 only)			
6	=	BSPP G3/4			
8	=	1" NPT			
16	=	SAE-16 (1-5/16-12) (standard for size 16 only)			
8	=	BSPP G1			
*	=	Special			

Model Codes Containing RED are non-standard items - Minimum quantities may apply. Contact HYDAC for information and availability

Line Bodies

Code	Part Number	Material	Ports Size	Pressure Rating	Weight
FH062-AS4	02600491	Aluminum, clear anodized	SAE-4	3500 psi (245 bar)	0.33 lbs (0.15 kg)
FH062-SS4	02600490	Steel, zinc plated	SAE-4	6000 psi (420 bar)	0.97 lbs (0.44 kg)
FH063-AS4	02600492	Aluminum, clear anodized	SAE-4	3500 psi (245 bar)	0.37 lbs (0.17 kg)
FH063-SS4	02600493	Steel, zinc plated	SAE-4	6000 psi (420 bar)	1.07 lbs (0.49 kg)
FH064-AS4	02600462	Aluminum, clear anodized	SAE-4	3500 psi (245 bar)	0.43 lbs (0.20 kg)
FH064-SS4	02600461	Steel, zinc plated	SAE-4	6000 psi (420 bar)	1.25 lbs (0.57 kg)
FH082-AS6	03011409	Aluminum, clear anodized	SAE-6	3500 psi (245 bar)	0.34 lbs (0.15 kg)
FH082-SS6	00560917	Steel, zinc plated	SAE-6	6000 psi (420 bar)	1.00 lbs (0.45 kg)
FH083-AS6	03011424	Aluminum, clear anodized	SAE-6	3500 psi (245 bar)	0.58 lbs (0.26 kg)
FH083-SS6	00560920	Steel, zinc plated	SAE-6	6000 psi (420 bar)	1.70 lbs (0.77 kg)
FH084-AS6	03011404	Aluminum, clear anodized	SAE-6	3500 psi (245 bar)	0.72 lbs (0.33 kg)
FH084-SS6	00563381	Steel, zinc plated	SAE-6	6000 psi (420 bar)	2.10 lbs (0.95 kg)
FH102-AS8	03037778	Aluminum, clear anodized	SAE-8	3500 psi (245 bar)	0.40 lbs (0.18 kg)
FH102-SS8	03037612	Steel, zinc plated	SAE-8	6000 psi (420 bar)	1.16 lbs (0.53 kg)
FH103-AS8	03038095	Aluminum, clear anodized	SAE-8	3500 psi (245 bar)	0.60 lbs (0.27 kg)
FH103-SS8	03037704	Steel, zinc plated	SAE-8	6000 psi (420 bar)	1.74 lbs (0.79 kg)
FH10S3-AS8	02582076	Aluminum, clear anodized	SAE-8	3500 psi (245 bar)	0.60 lbs (0.27 kg)
FH10S3-SS8	02582077	Steel, zinc plated	SAE-8	6000 psi (420 bar)	1.74 lbs (0.79 kg)
FH104-AS8	03038110	Aluminum, clear anodized	SAE-8	3500 psi (245 bar)	0.72 lbs (0.33 kg)
FH104-SS8	03037868	Steel, zinc plated	SAE-8	6000 psi (420 bar)	2.12 lbs (0.96 kg)
FH122-AS12	03053845	Aluminum, clear anodized	SAE-12	3500 psi (245 bar)	1.39 lbs (0.63 kg)
FH122-SS12	03053772	Steel, zinc plated	SAE-12	6000 psi (420 bar)	4.16 lbs (1.89 kg)
FH162-AS16	03037195	Aluminum, clear anodized	SAE-16	3500 psi (245 bar)	1.20 lbs (0.55 kg)
FH162-SS16	03032655	Steel, zinc plated	SAE-16	6000 psi (420 bar)	3.56 lbs (1.62 kg)
FH163-AS16	03037210	Aluminum, clear anodized	SAE-16	3500 psi (245 bar)	2.34 lbs (1.06 kg)
FH163-SS16	03036285	Steel, zinc plated	SAE-16	6000 psi (420 bar)	6.80 lbs (3.09 kg)
FH16S3-AS16	02582078	Aluminum, clear anodized	SAE-16	3500 psi (245 bar)	2.34 lbs (1.06 kg)
FH16S3-SS16	02582079	Steel, zinc plated	SAE-16	6000 psi (420 bar)	6.80 lbs (3.09 kg)
FH164-AS16	03037214	Aluminum, clear anodized	SAE-16	3500 psi (245 bar)	3.00 lbs (1.36 kg)
FH164-SS16	03035672	Steel, zinc plated	SAE-16	6000 psi (420 bar)	8.8 lbs (4.00 kg)
FHM455-AS20	02600747	Aluminum, clear anodized	SAE-20	3500 psi (245 bar)	5.88 lbs (2.66 kg)
FHM455-SS20	02600563	Steel, zinc plated	SAE-20	5000 psi (350 bar)	17.13 lbs (7.77 kg)

LINE BODIES & CAVITIES

Dimensions

2-way Line Body

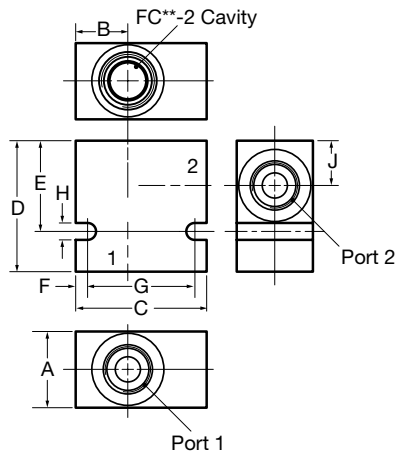

	FH06-2	FH08-2	FH10-2	FH12-2	FH16-2
A	1.0 (25.4)	1.13 (30)*	1.25 (32)*	2 (50)*	2 (50)*
B	1.0 (25.4)	0.748 (19)	0.866 (22)	1.24 (31.5)	1.24 (31.5)
C	2.0 (50.8)	2.0 (50.8)	2.19 (55)*	3 (75)*	3 (75)*
D	2.0 (50.8)	2.0 (50.8)	2.13 (55)*	3 (75)*	3 (75)*
E	1.5 (38.1)	1.5 (38)	1.5 (38)	2.252 (57.2)	2.252 (57.2)
F	0.25 (6.4)	0.13 (3.3)	0.2 (5)	0.197 (5)	0.197 (5)
G	1.5 (38.1)	1.62 (41.1)	1.75 (45)	2.559 (65)	2.559 (65)
H	0.28 (7.1)	0.28 (7.1)	0.28 (7.1)	0.339 (8.6)	0.339 (8.6)
J	0.55 (14.0)	0.61 (15.5)	0.74 (18.8)	0.989 (25.1)	0.989 (25.13)

dimensions are in inches (mm)

3-way Line Body

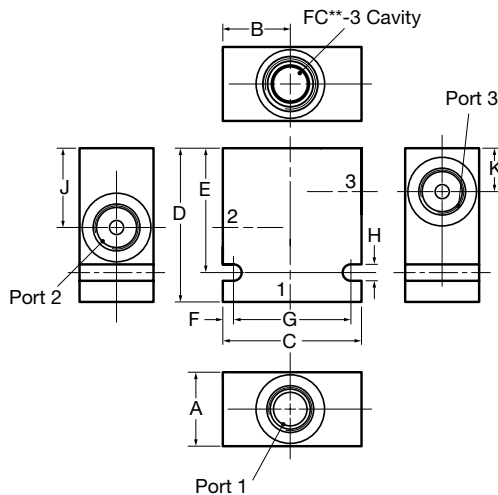

	FH06-3	FH08-3	FH10-3	FH10-S3	FH12-3
A	1.0 (25.4)	1.13 (30)*	1.25 (32)*	1.25 (30)	2.0 (50)*
B	1.0 (25.4)	1.25 (30)	1.16 (29.5)	1.25 (30)	2.0 (50)
C	2.0 (50.8)	2.5 (60)*	2.5 (60)*	2.50 (60)	4 (100)*
D	2.25 (57.2)	2.62 (66.5)	2.62 (66.5)	2.75 (69.9)	4.02 (102)
E	1.75 (44.5)	2.12 (53.8)	2.12 (53.8)	2.25 (57.2)	3.39 (86)
F	0.25 (6.4)	0.18 (4.6)	0.197 (5)	0.25 (6.4)	0.197 (5)
G	1.5 (38.1)	2 (50.8)	2 (50.8)	2.00 (50.8)	3.54 (90)
H	0.28 (7.1)	0.28 (7.1)	0.28 (7.1)	0.282 (7.16)	0.34 (8.6)
J	0.95 (24.1)	1.17 (29.7)	1.38 (35)	1.248 (31.70)	2.14 (54.4)
K	0.55 (14.0)	0.60 (15.2)	0.72 (18.3)	0.582 (14.78)	1.17 (29.75)

	FH16-S3	FH16-3
A	2.00 (50.8)	2 (50)*
B	2.00 (50.8)	2.5 (50.8)
C	3.50 (88.9)	4 (100)*
D	3.50 (88.9)	4.02 (102)
E	2.875 (73.03)	3.39 (86)
F	0.23 (5.8)	0.197 (5)
G	3.04 (77.22)	3.54 (90)
H	0.34 (8.6)	0.34 (8.6)
J	1.506 (38.25)	2.18 (55.4)
K	0.695 (17.65)	1.02 (25.9)

dimensions are in inches (mm)

*Note: Dimensions determined by manufacturing location (USA or Europe)

4-way Line Body

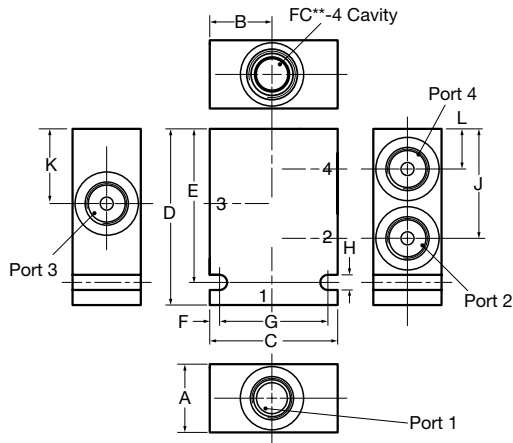

	FH06-4	FH08-4	FH10-4	FH12-4	FH16-4
A	1.0 (25.4)	1.13 (30)*	1.25 (32)*	2.0 (50)*	2.0 (50)*
B	1.0 (25.4)	1.25 (31.75)	1.16 (29.5)	2.0 (50)*	2.0 (50)*
C	2.0 (50.8)	2.5 (60)*	2.5 (60)*	4 (100)*	4 (100)*
D	2.63 (66.8)	3.25 (82.5)	3.25 (82.6)	5.2 (132)	5.2 (132)
E	2.13 (54.1)	2.83 (72)	2.83 (72)	4.49 (114)	4.49 (114)
F	0.25 (6.4)	.18 (4.6)	.18 (4.6)	.197 (5)	.197 (5)
G	1.5 (38.1)	2 (50.8)	2 (50.8)	3.54 (90)	3.54 (90)
H	0.28 (7.1)	.28 (7.1)	.28 (7.1)	.34 (8.6)	.34 (8.6)
J	1.34 (34.0)	1.73 (44)	2.02 (51.3)	3.1 (78.8)	3.24 (82.25)
K	0.95 (24.1)	1.17 (29.7)	1.38 (35.05)	2.14 (54.4)	2.18 (55.4)
L	0.55 (14.0)	.60 (15.2)	.74 (18.8)	1.17 (29.75)	1.02 (25.9)

dimensions are in inches (mm)

5-way Line Body

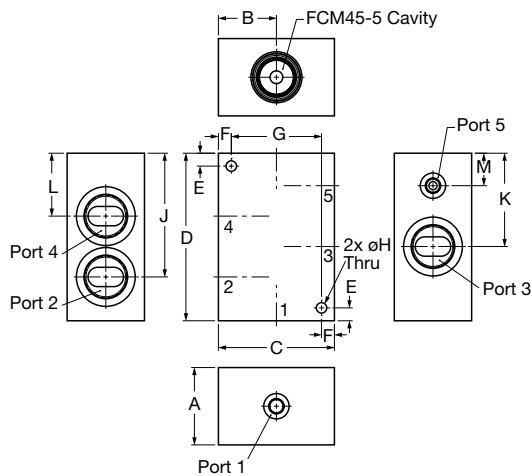

	FHM45-5
A	1.5 (38.1)
B	2.25 (57.2)
C	4.5 (114.5)
D	6.5 (165.1)
E	0.5 (12.7)
F	0.5 (12.7)
G	3.5 (88.9)
H	0.406 (10.3)
J	4.8 (121.9)
K	3.62 (91.9)
L	2.44 (61.9)
M	1.26 (32)

dimensions are in inches (mm)

*Note: Dimensions determined by manufacturing location (USA or Europe)

LINE BODIES & CAVITIES

2-way Cavities Size 6: FC06-2

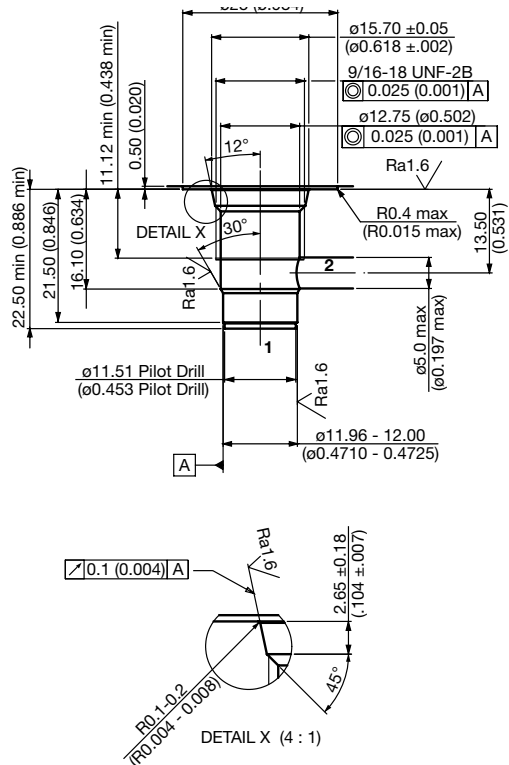

02582031
MILLIMETER (INCH)
Technical modifications reserved

FORM TOOLS
Rougher: 02582046
Finisher: 02582047

Size 6: FC06-S

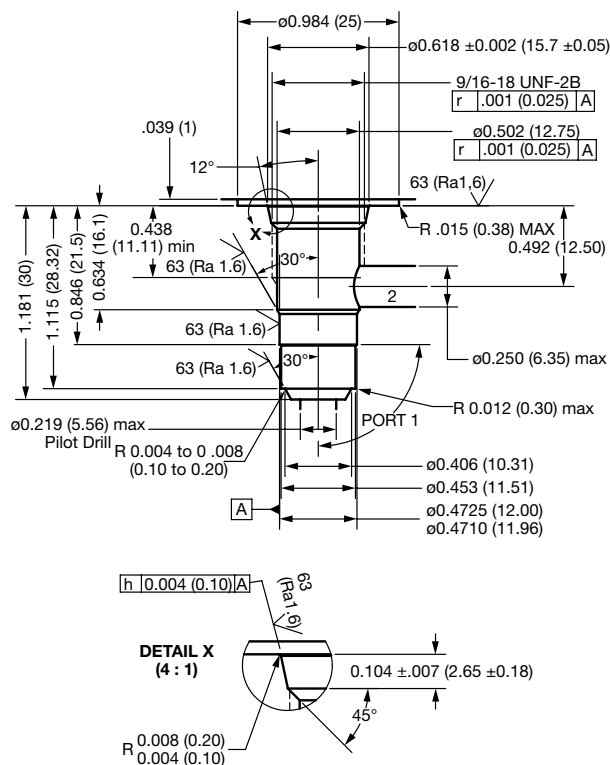

02587218
MILLIMETER (INCH)
Technical modifications reserved

FORM TOOLS
Rougher: 02587284
Finisher: 02587285

Size 8: FC08-2

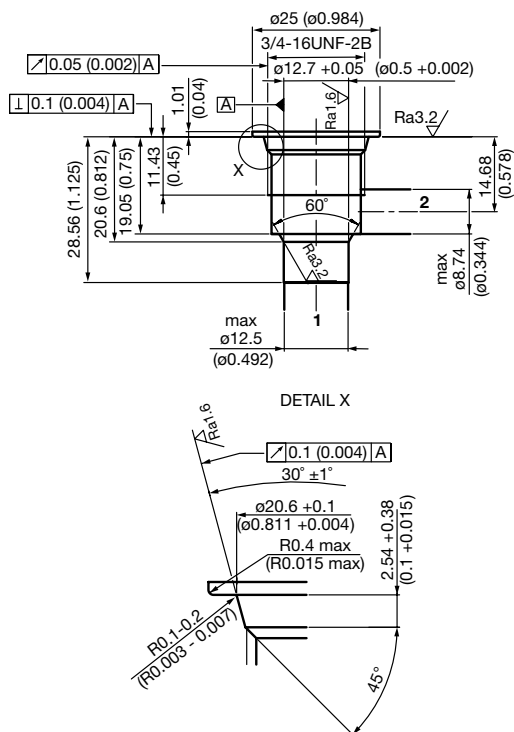

00555686
MILLIMETER (INCH)
Technical modifications reserved

FORM TOOLS
Rougher: 02580090
Finisher: 02580091

Size 10: FC10-2

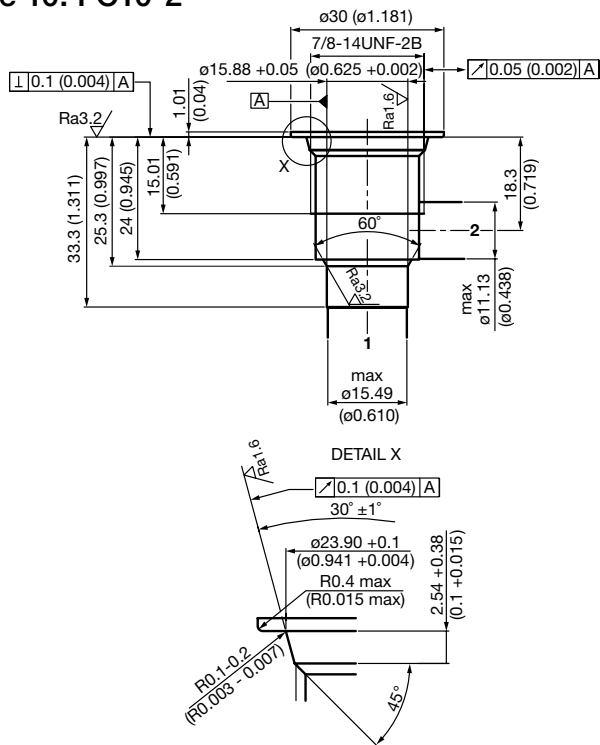

00555688
MILLIMETER (INCH)
Technical modifications reserved

FORM TOOLS
Rougher: 02580274
Finisher: 02580247

Size 12: FC12-2

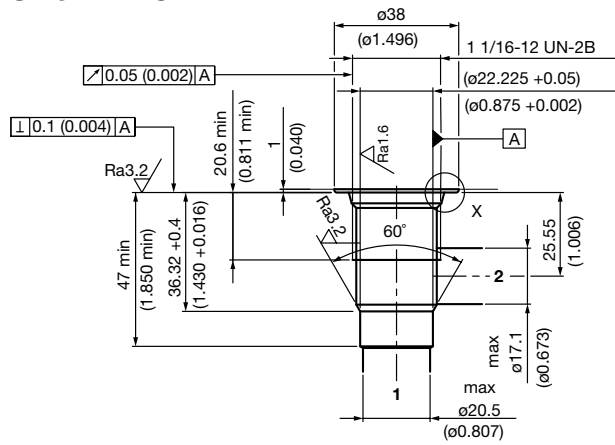

DETAIL X

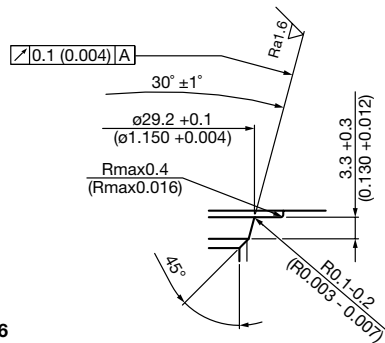

03046486
MILLIMETER (INCH)
Technical modifications reserved

FORM TOOLS
Rougher: 02580668
Finisher: 02580667

Size 16: FC16-2

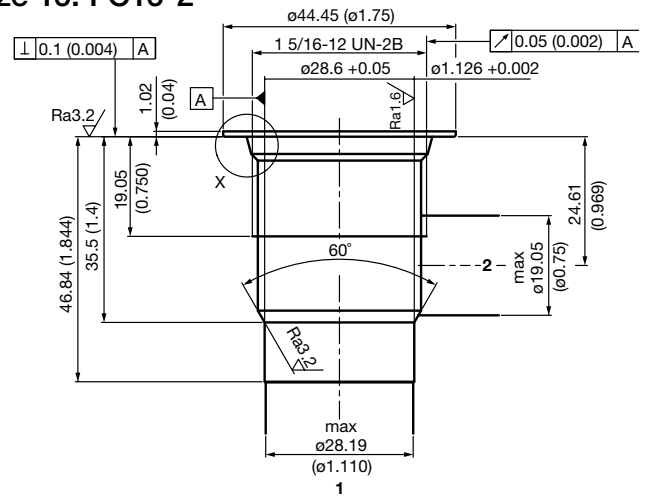

DETAIL X

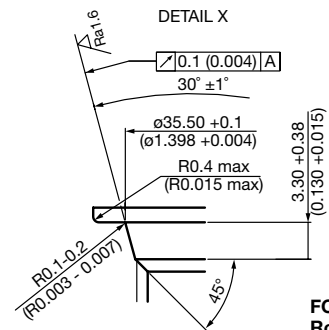

00555690
MILLIMETER (INCH)
Technical modifications reserved

FORM TOOLS
Rougher: 02580250
Finisher: 02582075

LINE BODIES & CAVITIES

3-way Cavities Size 6: FC06-3

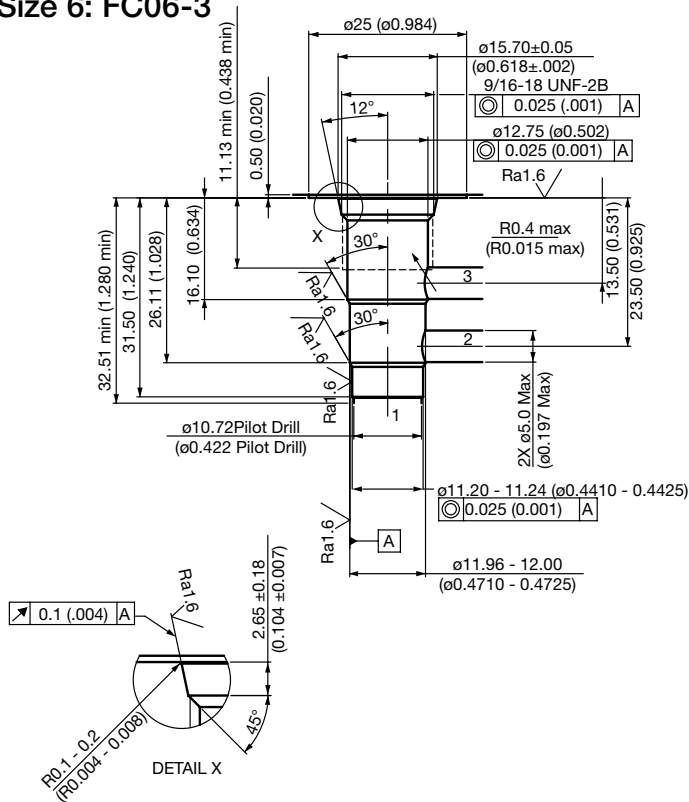

02582045
MILLIMETER (INCH)
Technical modifications reserved

FORM TOOLS
Rougher: 02582050
Finisher: 02582051

Size 8: FC08-3

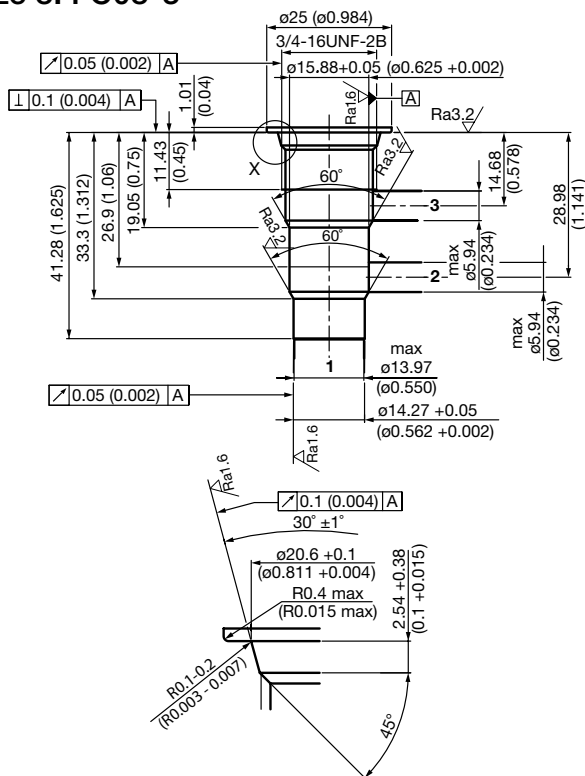

00555691
MILLIMETER (INCH)
Technical modifications reserved

FORM TOOLS
Rougher: 02580086
Finisher: 02580087

Size 10: FC10-3

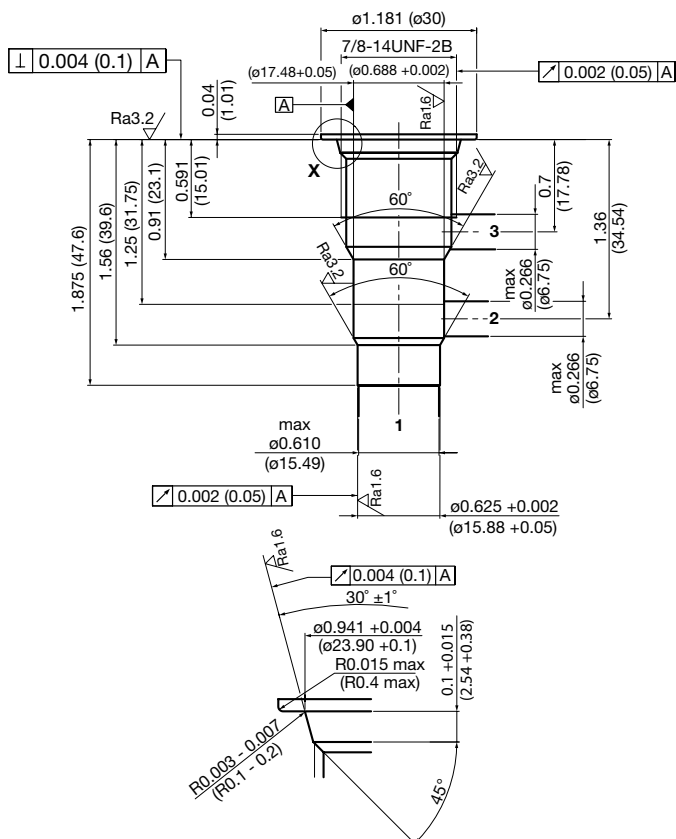

00555692
MILLIMETER (INCH)
Technical modifications reserved

FORM TOOLS
Rougher: 02580092
Finisher: 02580093

Size 10: FC10-S3

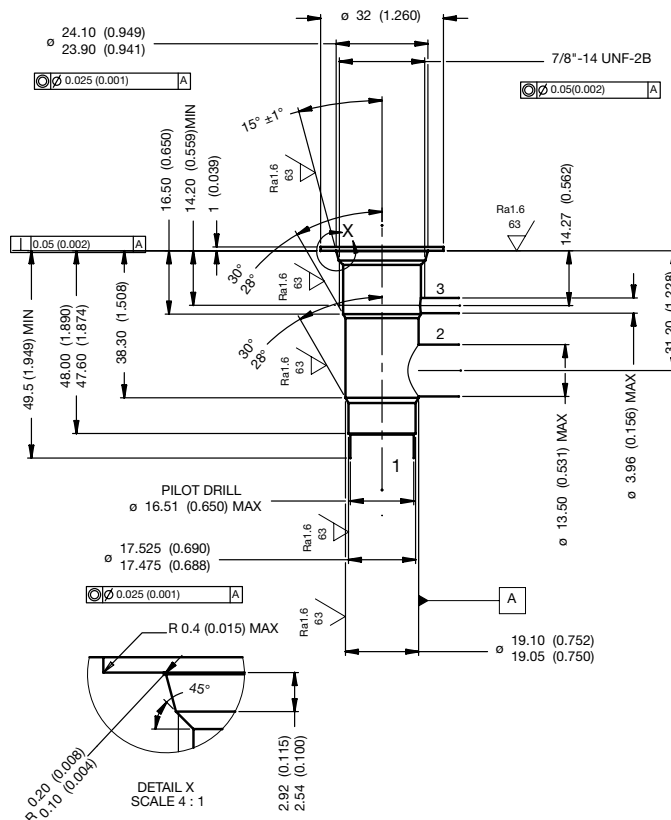

02581793
MILLIMETER (INCH)
Technical modifications reserved

FORM TOOLS
Rougher: 02581794
Finisher: 02581795

Size 12: FC12-3

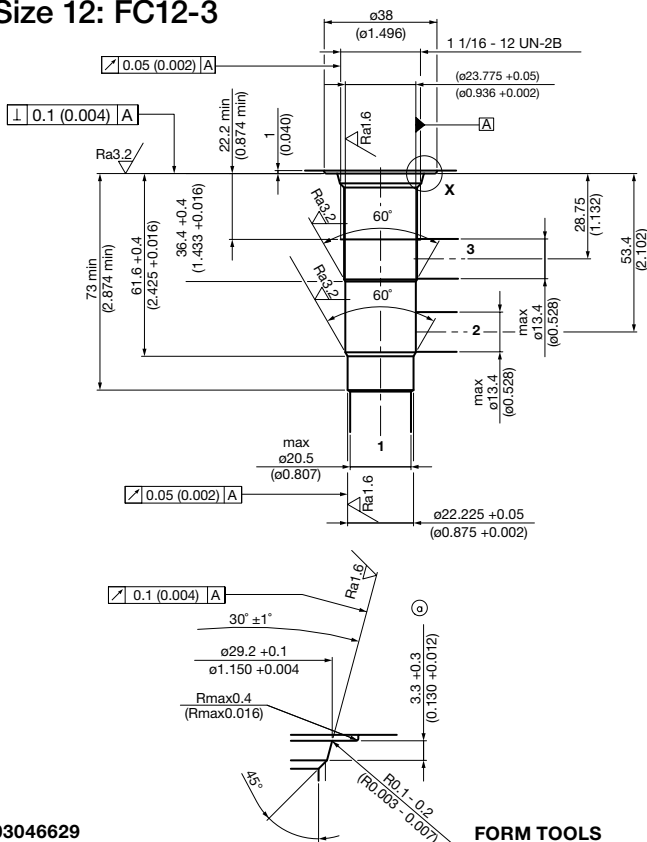

03046629
MILLIMETER (INCH)
Technical modifications reserved

FORM TOOLS
Rougher: 02582074
Finisher: 02582075

Size 16: FC16-3

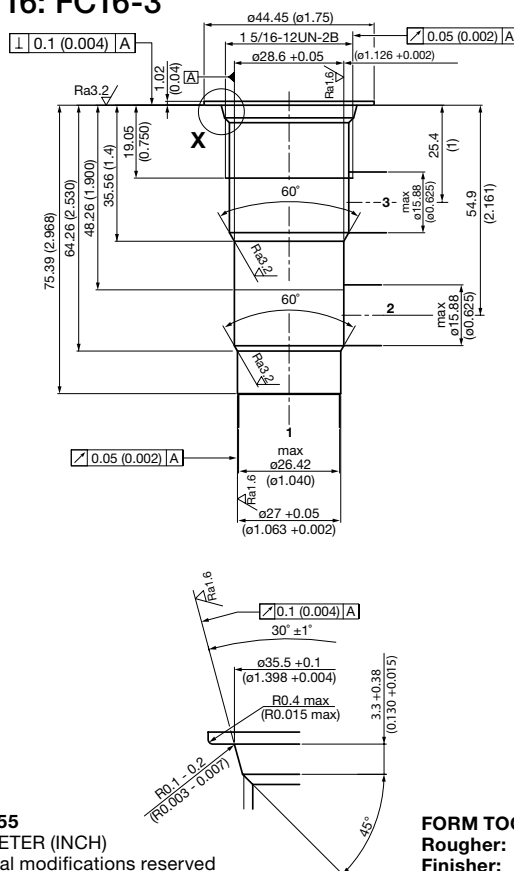

00561755
MILLIMETER (INCH)
Technical modifications reserved

FORM TOOLS
Rougher: 02580094
Finisher: 02580095

Size 16: FC16-S3

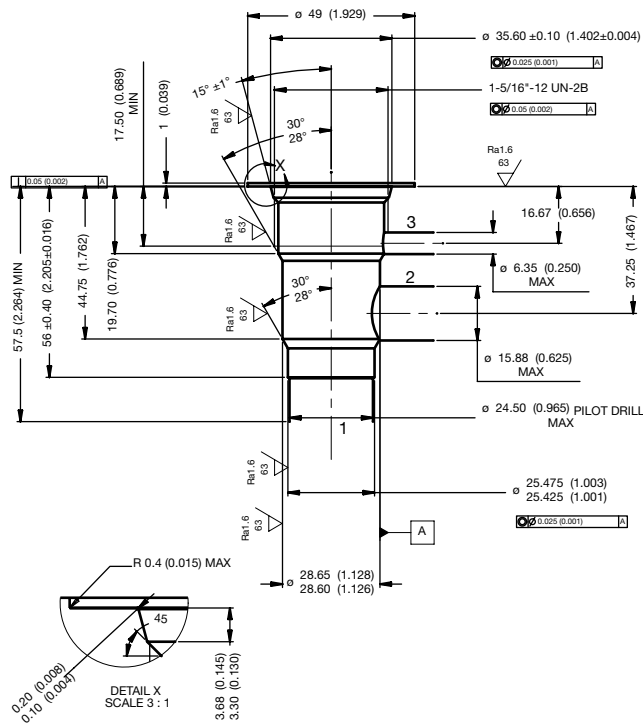

02581796
MILLIMETER (INCH)
Technical modifications reserved

FORM TOOLS
Rougher: 02581797
Finisher: 02581798

LINE BODIES & CAVITIES

4-way Cavities Size 6: FC06-4

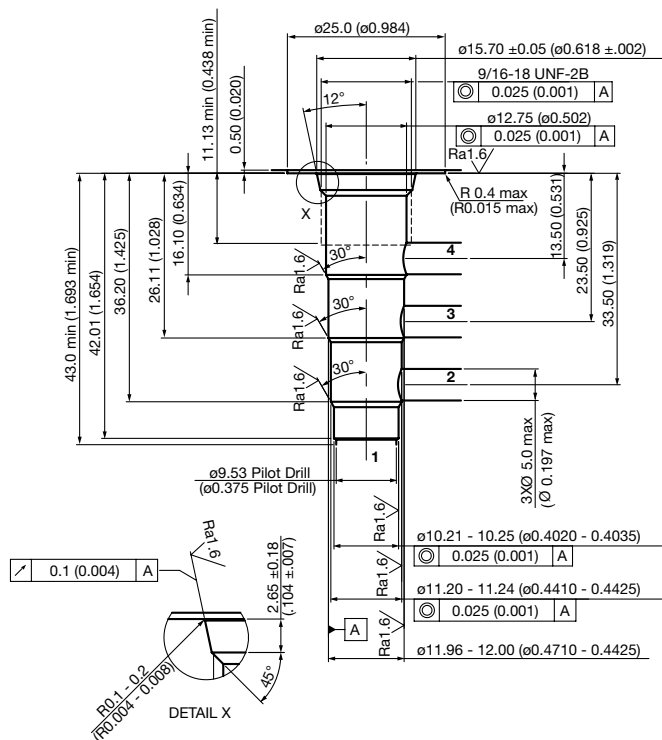

02581970
MILLIMETER (INCH)
Technical modifications reserved

FORM TOOLS
Rougher: 02582057
Finisher: 02582058

Size 8: FC08-4

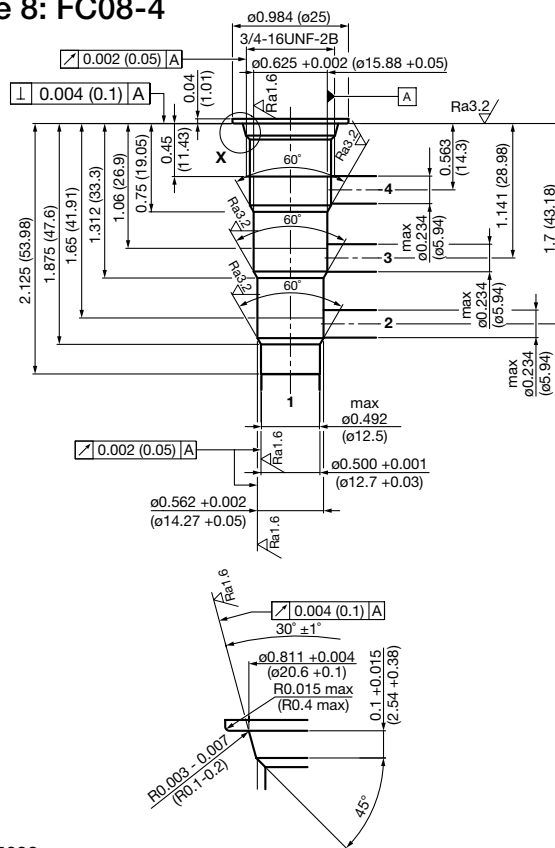

00555693
MILLIMETER (INCH)
Technical modifications reserved

FORM TOOLS
Rougher: 02580088
Finisher: 02580089

Size 10: FC10-4

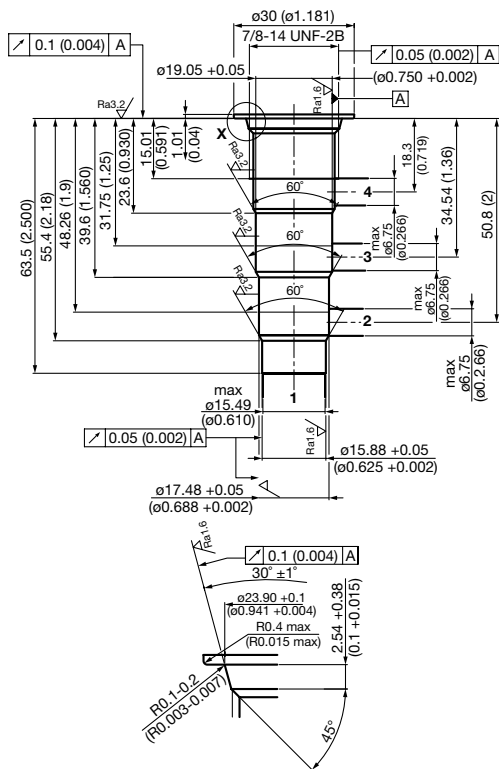

00555694
MILLIMETER (INCH)
Technical modifications reserved

FORM TOOLS
Rougher: 02580248
Finisher: 02580249

Size 12: FC12-4

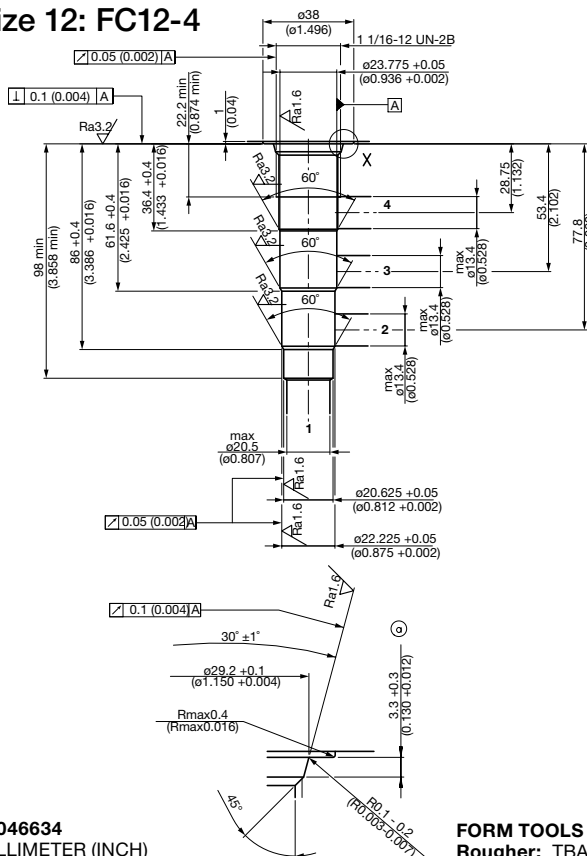

03046634
MILLIMETER (INCH)
Technical modifications reserved

FORM TOOLS
Rougher: TBA
Finisher: TBA

Size 16: FC16-4

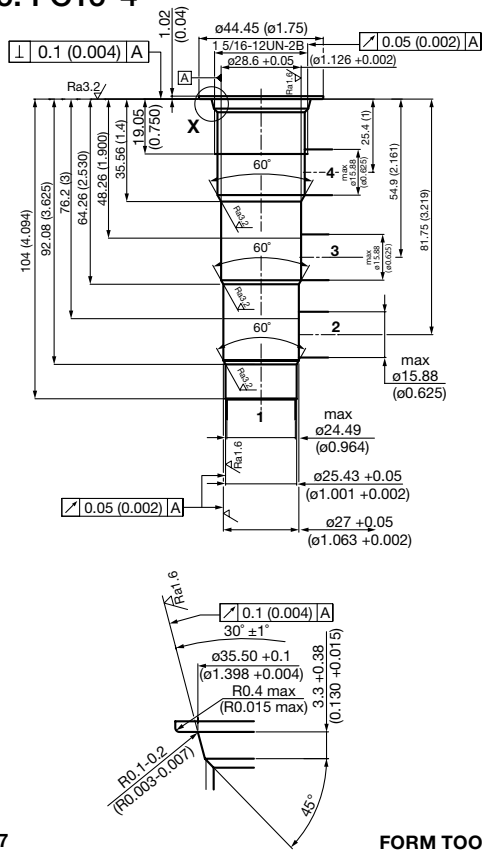

00562367
MILLIMETER (INCH)
Technical modifications reserved

FORM TOOLS
Rougher: 02580252
Finisher: 02580253

5-way Cavities Size M45: FCM45-5

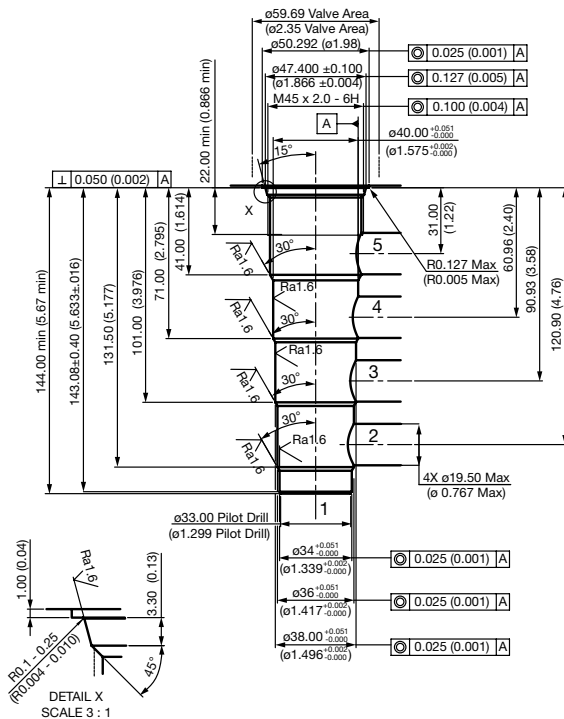

02582019
MILLIMETER (INCH)
Technical modifications reserved

FORM TOOLS
Rougher: 02582020
Finisher: 02582021

LINE BODIES & CAVITIES

Notes

A large grid of graph paper for taking notes, consisting of 20 columns and 30 rows of small squares.

L1

MANIFOLD ACCESSORIES

Size 06 Single Pilot Piston Assembly

Required Housing Bore

ø9.53 (0.375mm)

Standard Piston with Scarf Cut Ring

02610216

Scarf Cut Ring

Part No. 02600583
(material PTFE)

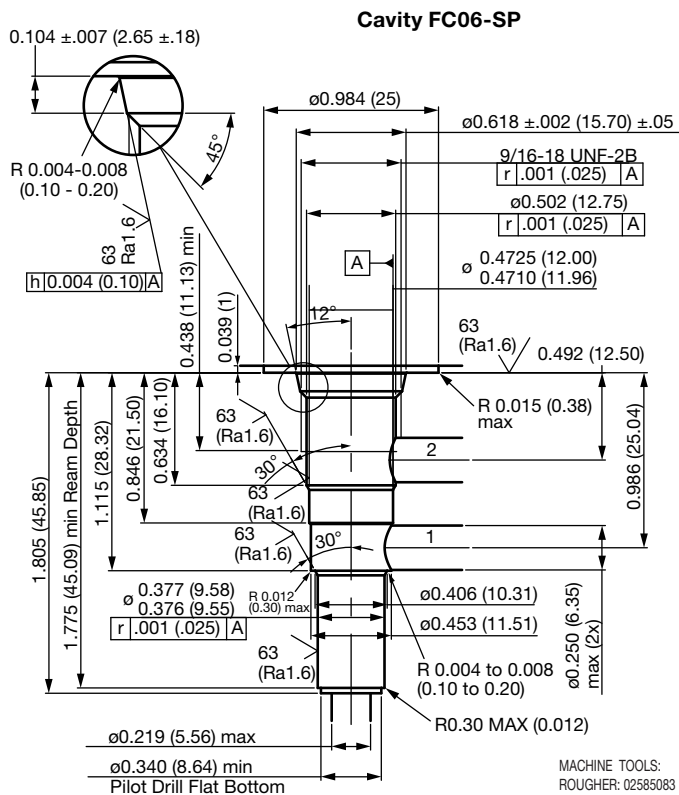
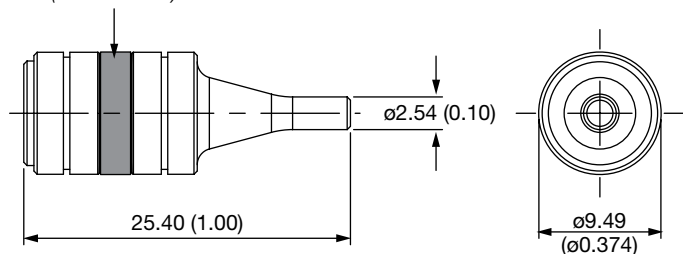

Size 06 Dual Pilot Piston Assembly

Required Housing Bore

ø9.53 (0.375mm)

Standard Piston with Scarf Cut Ring

02610217

Scarf Cut Ring

Part No. 02600583
(material PTFE)

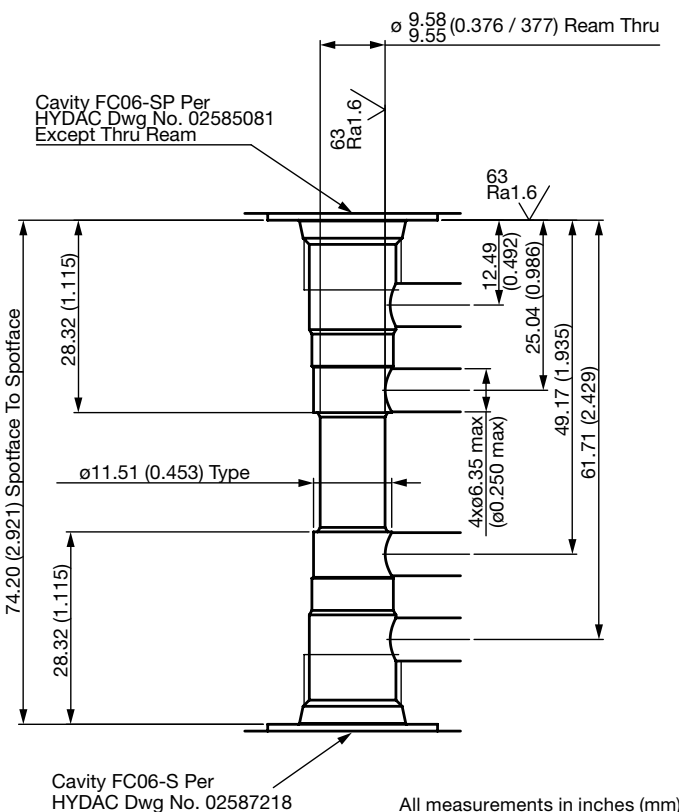
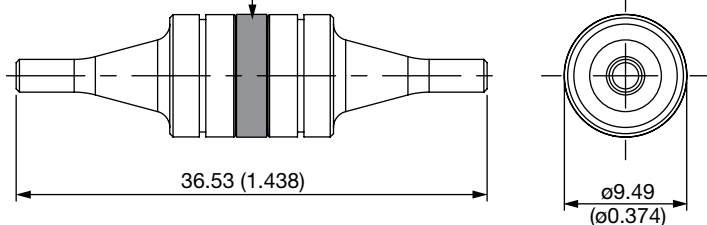

Sealed pistons should not be used with check valves that have <30 psi crack pressure.

Size 08 Single Pilot Piston Assembly

For use on RVS08A-01 Single Pilot Operated Check Valve Assembly

Cavity FC08-SP

Required Housing Bore
0.50" (12.7mm)

With Buna-N Seals
02610067

With Viton® Seals
02610068

With PTFE Ring (standard)
02610069

Note: Sealed models have a central O-ring.

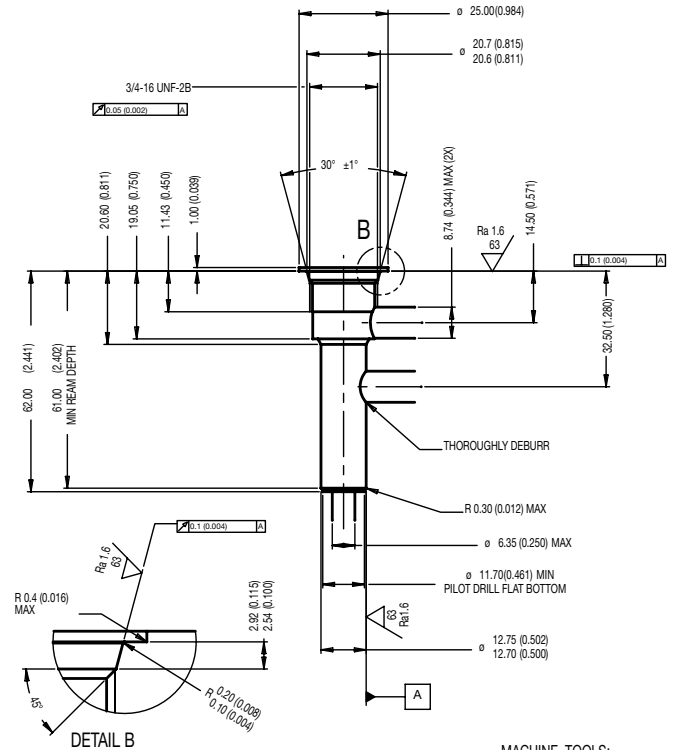
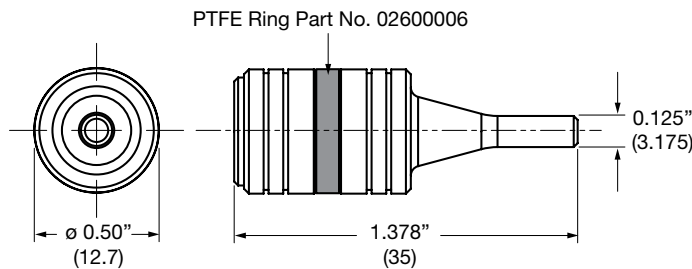

MACHINE TOOLS:
ROUGHER: 02581744
FINISHER: 02581745

Size 08 Dual Pilot Piston Assembly

For use on RVS08A-01 Dual Pilot Operated Check Valve Assembly

Required Housing Bore
0.50" (12.7mm)

With Buna-N Seals
02610070

With Viton® Seals
02610071

With PTFE Ring (standard)
02610072

Note: Sealed models have a central O-ring.

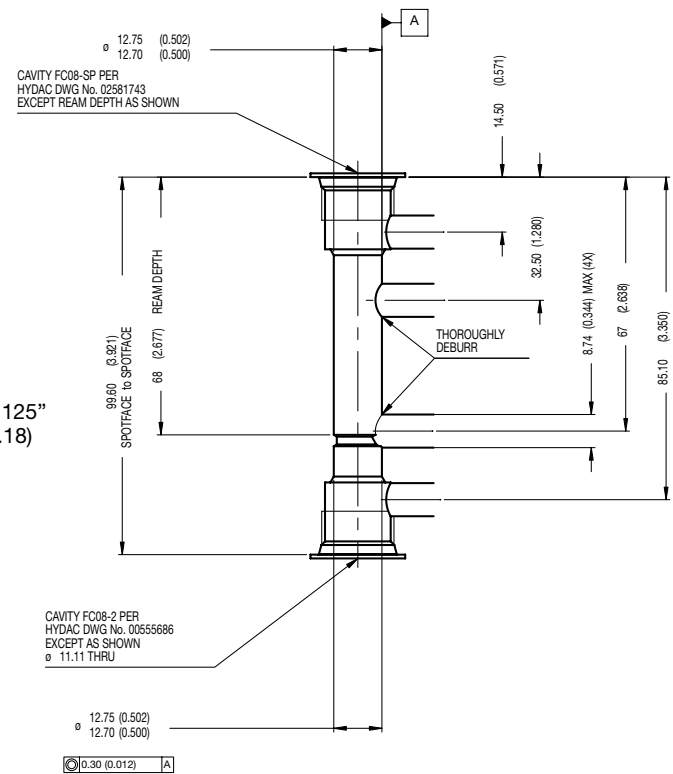
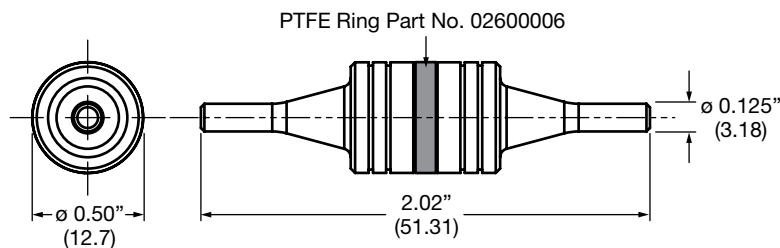

Sealed pistons should not be used with check valves that have <30 psi crack pressure.

All measurements in inches (mm)

MANIFOLD ACCESSORIES

Size 10 Single Pilot Piston Assembly

For use on RVS10A-01 Single Pilot Operated Check Valve Assembly

Cavity FC10-SP

Required Housing Bore
0.625" (15.88mm)

With Buna-N Seals
02610073

With Viton® Seals
02610074

With PTFE Ring (standard)
02610075

Note: Sealed models have a central O-ring.

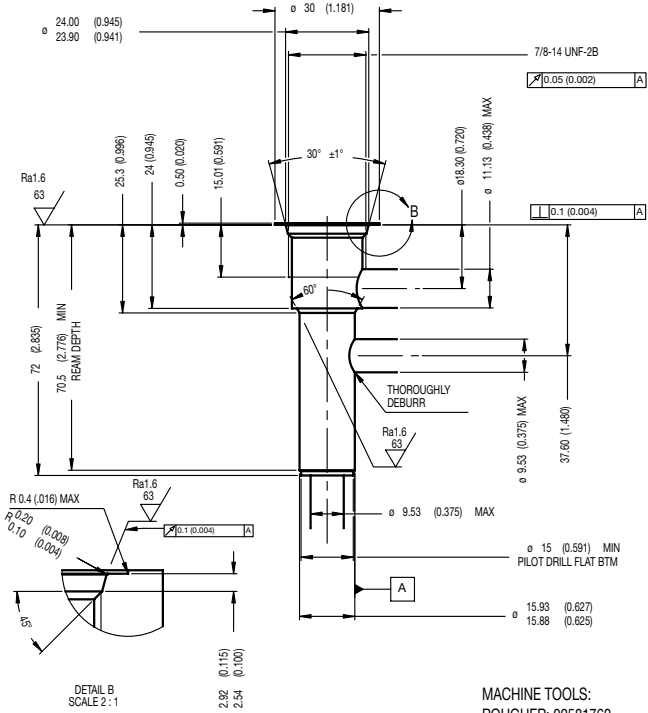
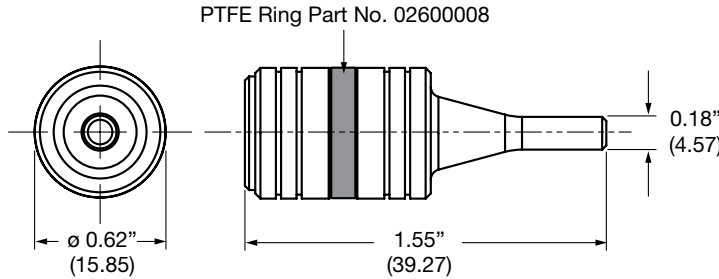

Size 10 Dual Pilot Piston Assembly

For use on RVS10A-01 Dual Pilot Operated Check Valve Assembly

Required Housing Bore
0.625" (15.88mm)

With Buna-N Seals
02610064

With Viton® Seals
02610065

With PTFE Ring (standard)
02610066

Note: Sealed models have a central O-ring.

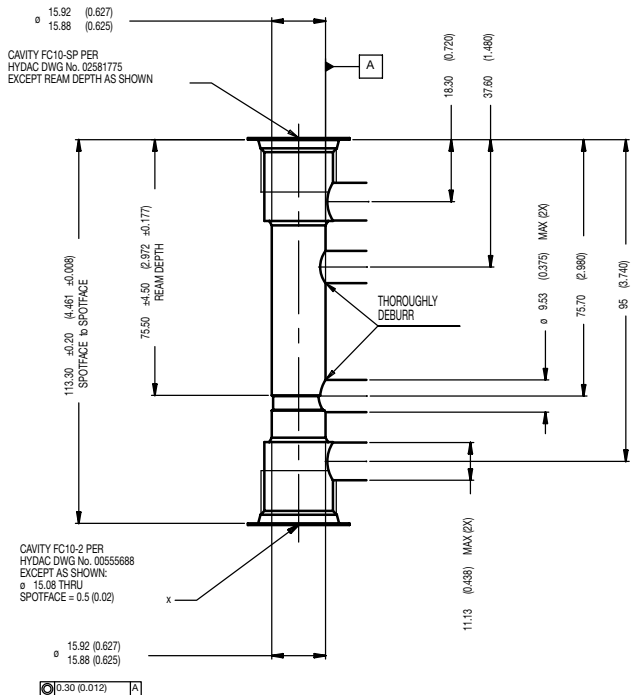
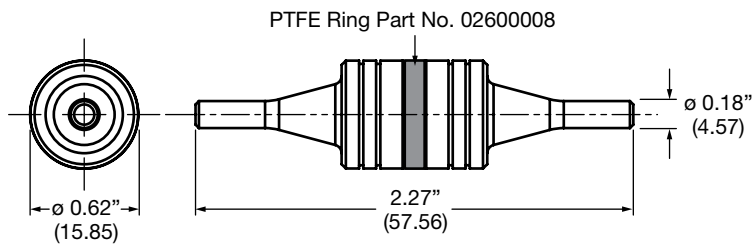

Sealed pistons should not be used with check valves that have <30 psi crack pressure.

All measurements in inches (mm)

Cavity Plugs

Material: Steel, Zinc-plated

Hydraulic Symbol

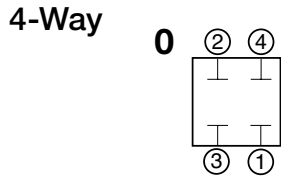
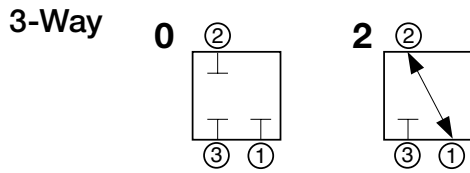
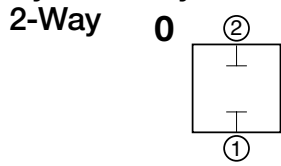

Model Code

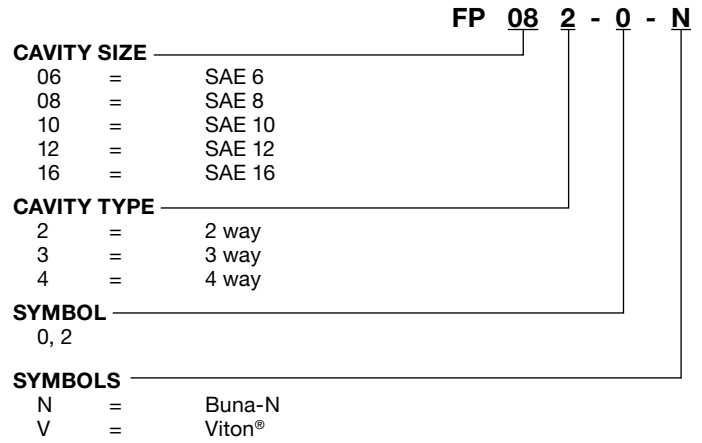

2-Way Cavity

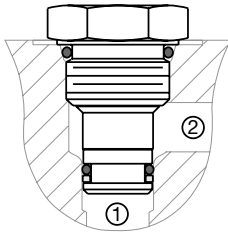

Part Number	Model Code
02610219	FP062-0-N
02610241	FP062-0-V
03012753	FP082-0-N
03012707	FP082-0-V
03014157	FP102-0-N
30314161	FP102-0-V
03064028	FP122-0-N
03064017	FP122-0-V
03056431	FP162-0-N
03056432	FP162-0-V

3-Way Cavity

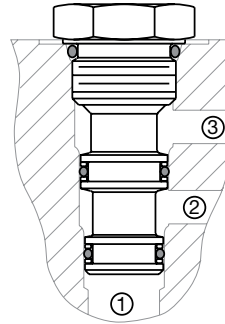

Part Number	Model Code
02610220	FP063-0-N
02610248	FP063-0-V
03012754	FP083-0-N
03012734	FP083-0-V
03022548	FP083-2-N
03022549	FP083-2-V
03014158	FP103-0-N
03014173	FP103-0-V
3158484	FP103-2-N
02610315	FP103-2-V
03082862	FP123-0-N
03081863	FP123-0-V
02610316	FP123-2-N
02610317	FP123-2-V
03056433	FP163-0-N
03056434	FP163-0-V
02610318	FP163-2-N
02610319	FP163-2-V

4-Way Cavity

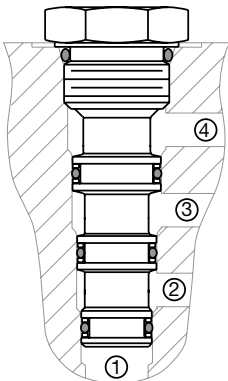

Part Number	Model Code
02610221	FP064-0-N
02610249	FP064-0-V
03012756	FP084-0-N
03012712	FP084-0-V
03014159	FP104-0-N
03014174	FP104-0-V
03082863	FP124-0-N
03088932	FP124-0-V
03082864	FP164-0-N
03088931	FP164-0-V

MANIFOLD ACCESSORIES

Notes



M1

MISCELLANEOUS PARTS

Seal Kits

O-Ring / Backup Ring

Includes all External, Wetted O-Rings & Back-up Rings

Cavity Size	Type	Seal Kit Buna-N		Seal Kit Viton	
		Model Code	Part No.	Model Code	Part No.
06	2-way	FS062-N	02610184	FS062-V	02610185
	3-way	FS063-N	02610186	FS063-V	02610187
	4-way	FS064-N	02610188	FS064-V	02610189
08	2-way	FS082-N	03033920	FS082-V	03051756
	3-way	FS083-N	03054795	FS083-V	02591059
	4-way	FS084-N	03071272	FS084-V	03071273
10	2-way	FS102-N	03033872	FS102-V	03051757
	3-way	FS103-N	03071274	FS103-V	03049443
		FS10S3-N	02610278	FS10S3-V	02610279
4-way	FS104-N	03051912	FS104-V	03071275	
12	2-way	FS122-N	03071298	FS122-V	03071299
16	2-way	FS162-N	03052427	FS162-V	03051758
	3-way	FS163-N	03071303	FS163-V	03071304
		FS16S3-N	02610198	FS16S3-V	02610199
4-way	FS164-N	03181644	FS164-V	03181675	
M45	5-way	FSM455-N	02610313	FSM455-V	02610314

Solenoid Valve Replacement Nuts

Coil Nut Kits For Size 6 *(parts shipped loose in bags)*

Model Code	Part Number
COIL NUT KIT <i>(Plastic Nut & O-Ring)</i> Used on push/pull type valves without manual override: WK06E, WK06G, WK06H, WK06J, WK06Z	02610299
COIL NUT KIT <i>(Plastic Nut & O-Ring)</i> Used on push type valves without manual override: WK06C, WK06W, WK06Y, WS06Y	02610300

Solenoid Valve Replacement Nuts

Coil Nut Kits For Sizes 8, 10, 12 & 16 *(parts shipped loose in bags)*

Model Code	Part Number
COIL NUT KIT <i>(Plastic Nut & O-Ring)</i> Used on push type valves without manual override: WS_W, WS_V, WS_Y, WS_YR, WK_A, WK_C, WK08D, WK08K, WK08L, WK10L, WK_N, WK_R, WK_Y, WK_V, WK08Z	02593441
COIL NUT KIT <i>(Plastic Nut Rubber Cap & O-Ring)</i> Used on push type valves with manual override: WS_W, WS_V, WS_Y, WS_YR, WK_A, WK_C, WK08D, WK08K, WK08L, WK10L, WK_N, WK_R, WK_Y, WK_V, WK08Z	02590791
COIL NUT KIT <i>(Plastic Nut & O-Ring)</i> Used on push/pull type valves without manual override: WS_Z, WK10E, WK10G, WK10H, WK10J, WK10T, WK07L, WK10D, WK10K, WK_P, WK_X, WK10Z, WK_W, WK08E, WK08J	02593026
COIL NUT KIT <i>(Plastic Nut & O-Ring)</i> Used on push/pull type valves with manual override: WS_Z, WK10E, WK10G, WK10H, WK10J, WK10T, WK07L, WK10D, WK10K, WK_P, WK_X, WK10Z, WK_W, WK08E, WK08J	02590809

Pressure, Flow Control and Counterbalance Valve Adjustment Kits

Direct Acting Pressure Control, Flow Control, and Counterbalance Valves

Model Code	Part Number
H-adjust kit, hand knob adjustment kit to convert standard option V, screw adjust valve, to option H, hand-knob model.	02591592
F-adjust kit, fixed/tamper resistant adjustment kit to convert standard option V, screw adjust valve, to option F, fixed/tamper-resistant model.	02591593
K-adjust kit, covered adjustment kit to convert standard option V, screw adjust valve, to option K, fixed/covered nut model.	03056129

Pilot Operated Pressure Control Valves

Model Code	Part Number
H-adjust kit, hand knob adjustment, pilot valve kit to convert standard option V, screw adjust valve, to option H, hand-knob model.	02592932
F-adjust kit, fixed/tamper resistant adjustment, pilot valve kit to convert standard option V, screw adjust valve, to option F, fixed/tamper-resistant model.	02593440
K-adjust kit, covered adjustment, pilot valve kit to convert standard option V, screw adjust valve, to option K, fixed/covered nut model.	03149319

Form Tools

Description

Cavity form tools, necessary for correctly manufacturing HYDAC cavities, are available for purchase. Each cavity has a separate roughing and finishing tool. Roughing tools are made of high-speed steel (HSS). Finishing tools are made of carbide. They are suitable for machining in both aluminum and steel material.

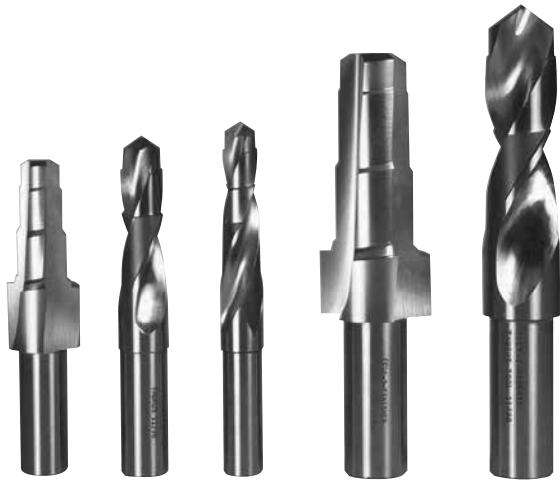

Cavity	Rougher Part No. High Speed Steel (HSS)	Shank \varnothing inch	Finisher Part No. Carbide	Shank \varnothing inch
FC06-2	02582046	0.500	02582047	0.500
FC06-3	02582050	0.750	02582051	0.750
FC06-4	02582057	0.750	02582058	0.750
FC08-2	02580090	0.625	02580091	0.750
FC08-3	02580086	0.625	02580087	0.750
FC08-4	02580088	0.625	02580089	0.750
FC10-2	02580274	0.750	02580247	0.750
FC10-3	02580092	0.750	02580093	0.750
FC10-S3	02581794	0.750	02581795	0.750
FC10-4	02580248	0.750	02580249	0.750
FC12-2	02580668	1.000	02580667	1.000
FC12-3	02582074	1.000	02582075	1.000
FC16-2	02580250	1.000	02580251	1.000
FC16-3	02580094	1.000	02580095	1.000
FC16-S3	02581797	1.000	02581798	1.000
FC16-4	02580252	1.000	02580253	1.000
FCM45-5	02582020	1.000	02582021	1.000



CONTACT DATA

COMPANY: _____ PRIMARY CONTACT: _____

PH: _____ FAX: _____ E-MAIL: _____

PROJECT NAME: _____ OEM: _____

DATE SUBMITTED: _____ REQUIRED DATES: Quotation: _____

Prototype: _____

Production: _____

ATTACHED INFO: Circuit Drawing Dimensional Drawing

Function Sequence Other: _____

QUANTITIES / INVENTORY

QUANTITIES TO BE QUOTED _____ PROTOTYPE: _____

PRODUCTION: _____

ORDER FREQUENCY: AS REQUIRED Est. Quantity & Frequency: _____

BLANKET ORDER Qty./Release _____ Monthly Quarterly

Semi-Ann Annual

SPECIAL STOCKING REQUIREMENTS: _____

TECHNICAL SUMMARY

DUTY CYCLE: : Continuous Intermittent

Describe cycle: _____

FLOW & PRESSURE: GPM: _____ PSI: _____ (operating)

(Include ALL different flows and pressures (max. intermittent)

- main supply + functions)

ELECTRICAL: Voltage: DC AC Operating _____ Max _____ Min _____

Connection Type: _____ (see valve data sheet for options)

TEMPERATURE: Oil Operating Temp. Range: _____ Ambient Temp. Range: _____

FLUID: : Petroleum Based Other: _____ Viscosity @ Op. Temp.: _____

SEAL MATERIAL: Buna-N Viton Other: _____

BLOCK MATERIAL: Aluminum (6061) Steel Other: _____

DESIGN RESTRICTIONS: Overall Dim. (Envelope) Cartridge Location

(CAD drawing, or sketch, should be included) Mounting Hole Location Port Location

FINISH PROCESS

SURFACE FINISH: Anodize Zinc Plate (Color and appearance specifics should be supplied in detail.)

Phosphate Paint

TESTING: : No Testing Data Logged Performance

Functions Only Special - Specs. Included

DOCUMENTATION

BLOCK ASSEMBLY DRAWING: Standard - supplied for prototype approval

Req'd w/Quote

(extends time to quote, factory agreement required in advance)

TEST COMPLIANCE: No Doc. Req'd Pass/Fail Doc. Individ. Test Results

DESIGN RESTRICTIONS

Overall dimensions, mounting requirements, unusual field conditions/forces etc.:
(Specifics should be supplied in detail.)

Valves		
Model Code	Qty.	Position
_____	_____	_____
_____	_____	_____
_____	_____	_____
_____	_____	_____
_____	_____	_____
_____	_____	_____
_____	_____	_____
_____	_____	_____
_____	_____	_____
_____	_____	_____

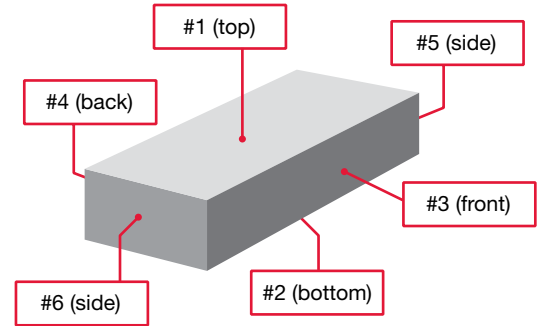

Ports			
Size / Type	Qty.	Labels	Position
_____	_____	_____	_____
_____	_____	_____	_____
_____	_____	_____	_____
_____	_____	_____	_____
_____	_____	_____	_____
_____	_____	_____	_____

HYDRAULIC CIRCUIT

Please draw your hydraulic circuit or attach existing print out.

Ordering HYDAC Literature...

HYDAC literature is available for ordering via our website, www.hydac-na.com then click on the **Downloads** button to proceed with ordering printed copies **(digital versions excluded)* or email us at HYD.catalog@hydac-na.com using the appropriate Part Number (PN) and name. Other brochures, manuals and technical documents are also available when ordering from our website.



Overview Brochure
PN02088157



Filters Catalog
PN02081318



Accumulators Catalog
PN02068195



Electronics Catalog*
(online only)



Compact Hydraulics
Catalog - PN02087369



Standard Coolers
Catalog - PN02085359

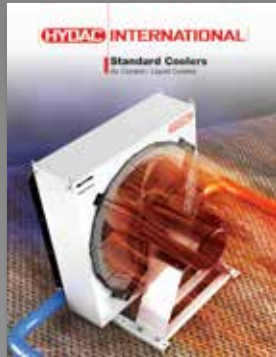

Filter Systems Catalog
PN02075860

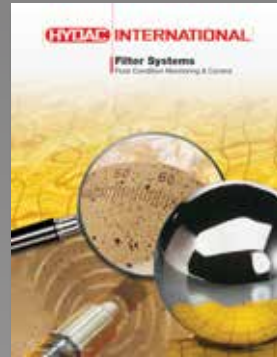

Control Technology*
Catalog (online only)

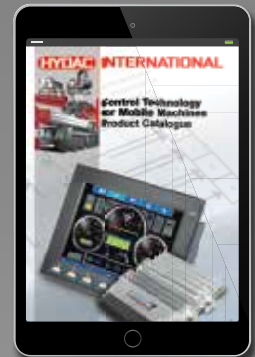

Accessories Catalog
PN02080105



Mobile Valves Brochure
PN02092408

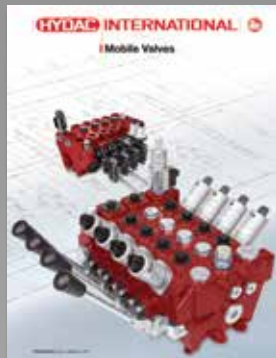

Hydraulic Cylinders
Brochure (Release: TBD)



Process Technology*
Catalog (online only)



*These catalogs are digital file versions only.

Various market and product brochures are also available for ordering.



HYDAC TECHNOLOGY CORPORATION
HYDAC CORPORATION

2260 City Line Road
Bethlehem, PA 18017
+1.610.266.0100

HYD.catalog@hydac-na.com
www.hydac-na.com



PN#02087369 / 10.19 / CHD1110-1389