

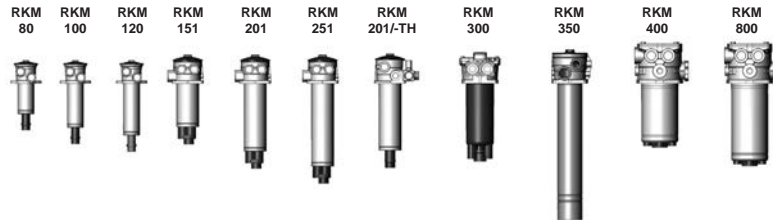

Return line and Suction Boost Filter RKM up to 850 l/min, up to 10 bar



1. TECHNICAL SPECIFICATIONS

1.1 FILTER HOUSING

Construction

The filter housings are designed in accordance with international regulations. They consist of a filter head, filter bowl and a screw-on or bolt-on cover plate.

Standard equipment:

- with bypass valve
- with back-pressure valve
- without anti-cavitation valve

Application

RKM return line & suction boost filters are ideally suited for use in equipment with two or more circuits. In particular this filter is the "first choice" for mobile machinery using hydrostatic drives (e.g. wheel loaders, fork-lift trucks, harvesting machines), if the return flow is greater than the flow required on the suction side under operating conditions.

Function

The return flow of the operating hydraulics is supplied to the filter via one or several inlets "A" and is cleaned by the filter element (full flow return line filtration). A pressure of 0.5 bar (standard) is applied inside the element by the back-pressure valve "V1".

This ensures that the filtered return line flow is available to the hydrostatic feed pumps connected in "B" ports (full flow suction boost filtration). The risk of cavitation is significantly reduced. The excess flow is drained to the tank via port "T". A bypass valve "V2" (standard = 2.5 bar) is fitted to relieve excessive back-pressures in the element (important on cold starts when viscosity is high). This valve arrangement ensures that only finely filtered oil is available to the suction port during operation (exception: RKM 350).

With optional valve "V3", oil can be drawn from the tank for short periods, e.g. initial filling, venting after changing element.

1.2 FILTER ELEMENTS

The filter elements used in RKM filters are notable for low back-pressures, especially at high viscosities (e.g. cold starts).

1.3 FILTER SPECIFICATIONS

Nominal pressure	10 bar
Temperature range	-30 °C to +100 °C (short-term: -40 °C)
Material of filter head	Aluminium
Material of filter bowl	Steel (all RKM except RKM 300) Polyamide (RKM 300)
Material of cover plate	Polyamide (RKM 80 to 251, 350) Aluminium (RKM 300, 400, 800)
Type of clogging indicator	VMF – Connection thread G 1/8
Pressure setting of the clogging indicator	-0.2 bar (vacuum pressure) 2 bar (back-pressure) (others on request)
Bypass cracking pressure (V2)	2.5 bar (others on request)
Setting for back-pressure valve (V1)	0.5 bar (others on request)

HYDAC filter elements are validated and their quality is constantly monitored according to the following standards:

- ISO 2941, ISO 2942, ISO 2943, ISO 3724, ISO 3968, ISO 11170, ISO 16889

Filter elements are available with the following pressure stability values:

Mobilemicron® (MM): 10 bar

1.4 SEALS

Perbunan (=NBR)

1.5 MOUNTING

Tank-top filter

1.6 SPECIAL MODELS AND ACCESSORIES

- with bleed valve
- with multiport head (only RKM 80 to 251; see point 2.4)
- with integral thermal bypass valve (only RKM 151, 201, 251; see point 2.5)
- with anti-cavitation valve (V3)

1.7 SPARE PARTS

See Original Spare Parts List

1.8 CERTIFICATES AND APPROVALS

On request

1.9 COMPATIBILITY WITH HYDRAULIC FLUIDS ISO 2943

- Hydraulic oils H to HLPD DIN 51524
- Lubrication oils DIN 51517, API, ACEA, DIN 51515, ISO 6743
- Compressor oils DIN 51506
- Biodegradable operating fluids VDMA 24568 HETG, HEES, HEPG
- Fire-resistant fluids HFA, HFB, HFC und HFD
- Operating fluids with high water content (>50% water content) on request

1.10 IMPORTANT INFORMATION

- Filter housings must be earthed.
- When using electrical clogging indicators, the electrical power supply to the system must be switched off before removing the clogging indicator connector.

Symbol for hydraulic systems

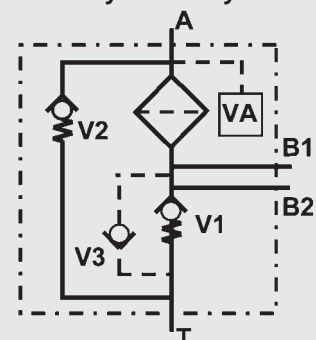

VA = clogging indicator

2. MODEL CODE (also order example)

RKM MM 300 B T F 10 W 0 . X /-NR-EV

2.1 COMPLETE FILTER

Filter type

RKM

Filter material of element

MM Mobilemicron

Size of filter or element

RKM: 80, 100, 120, 151, 201, 251, 300, 350, 400, 800

Operating pressure

B = 10 bar

V = 7 bar (for RKM with clogging indicator up to max. 7 bar operating pressure)

Type and size of suction line

Type	Connection	Filter size									
		80	100	120	151	201	251	300	350	400	800
T	2 x CS1¼				•	•	•	•			
V	2 x G1				•	•	•				
X	1 x G1	•	•	•					•		
Y	1 x G¾	•	•	•							
Z	to customer spec.	•	•	•	•*	•*	•*			•	•

Type and size of return line

Type	Connection	Filter size									
		80	100	120	151	201	251	300	350	400	800
C	1 x G¾	•	•	•							
D	1 x G1	•	•	•							
E	1 x G1¼				•	•	•				
F	1 x CS1½							•			
G	1 x G1½								•		
Z	to customer spec.	•°	•°	•°	•*°	•*°	•*°			•	•

° only in conjunction with multiport head

* only in conjunction with thermal bypass valve

Filtration rating in µm

MM: 8, 10, 15

Type of clogging indicator

W without port for clogging indicator

Y plastic blanking plug in indicator port

A steel blanking plug in indicator port

F pressure switch

K return line & vacuum pressure gauge

R return line pressure gauge

UF vacuum switch

for other clogging indicators see brochure no. 7.050../..

Type code

0 no indicator

1-5 see point 2.6

Modification number

X the latest version is always supplied

Supplementary details

no details = standard (without anti-cavitation valve; seals NBR; bypass valve 2.5 bar; back-pressure valve 0.5 bar)

B3-CV3.5 bypass valve with 3 bar cracking pressure and back-pressure valve with 3.5 bar cracking pressure (only RKM 350)

B6-CV3 bypass valve with 6 bar cracking pressure and back-pressure valve with 3 bar cracking pressure (only RKM 100, 300)

ES vent plug

EV air bleed valve

NR anti-cavitation valve (not on RKM 350)

NRF125 anti-cavitation valve and coarse strainer 125 µm (not on RKM 350)

ND pressure release valve in back-pressure valve

UT filter suitable for use when immersed horizontally in oil

V FPM seals

xxxx only RKM 80 to 251 (see point 2.4)

xxxxxxx only RKM 400 and 800 (see point 2.4)

THxx only RKM 151, 201, 251 (see point 2.5)

for symbols see point 2.7

2.2 REPLACEMENT ELEMENT

0300 RK 010 MM /-V

Size

0080, 0100, 0120, 0151, 0201, 0251, 0300, 0350, 0400, 0800

Type

RK

Filtration rating in µm

MM 008, 010, 015

Filter material

MM

Supplementary details

V FPM seal

2.3 REPLACEMENT CLOGGING INDICATOR

VMF 2 E . X

The return line indicator monitors the level of contamination in the element.

The vacuum indicator monitors the suction side pressure.

Type

VMF thread G 1/8

Pressure setting

0.2 -0.2 bar (vacuum pressure)

2 2 bar (back-pressure)

} others on request

Type of clogging indicator (see Point 2.1)

Modification number

X the latest version is always supplied

Supplementary details

V only for types B, BM, LE, LZ and C /-EX2G (all other clogging indicators have FPM seals as standard)

2.4 PORT CONFIGURATION RKM 80 TO 251 MULTIPORT HEAD AND RKM 400 AND 800

Since there are numerous options for machining the ports on the multiport head and the head of the RKM 400/800, the general code BZZ is selected here. In order to determine the position and size of the ports, a 5-digit or a 9-digit code is added as a supplementary detail. This is determined using the table below. Unused ports are indicated by a "0".

R = return port; S = suction port

Port configuration RKM 80, 100, 120 Multiport

Position in code	1	2	3	4	5
Connection	R1	R2	R3	S1	S2
G 1/2		(B)	(B)	B	B
G 3/4	(C)	C	C	(C)	(C)
G1	D				
Port plugged	0	0	0	0	0
Special port	Z	Z	Z	Z	Z

Example: RKM MM 100 BZZ 15 W 1.0 /-CBBCC

Port configuration RKM 151, 201, 251 Multiport

Position in code	1	2	3	4	5
Port	R1	R2	R3	S1	S2
G 3/4		(C)	(C)	C	C
G 1	D	D	D	(D)	(D)
G 1 1/4	(E)				
Port plugged	0	0	0	0	0
Special port	Z	Z	Z	Z	Z

Example: RKM MM 201 BZZ 15 W 1.0 /-ECCDD

Port configuration RKM 400 and 800

Position in code	1	2	3	4	5	6	7	8	9
Port	R1	R2	R3	S4	S5	S6	S7	S8	S9
SAE DN 50	(1)								
SAE DN 65	2								
G1		1	1	A	A	1	1	A	A
G1 1/4		2	(2)	B	B	(2)	(2)	B	B
G1 1/2		3	3	(C)	(C)	3	3	C	C
Port plugged		(0)	0	0	0	0	0	(0)	(0)
Special port		Z	Z	Z	Z	Z	Z	Z	Z

Example: RKM MM 400 BZZ 15 A 1.0 /-102CC2200

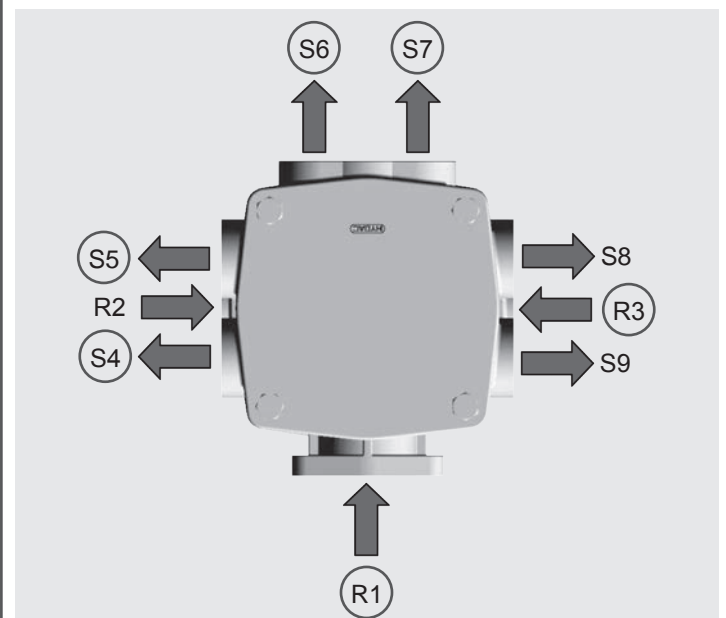
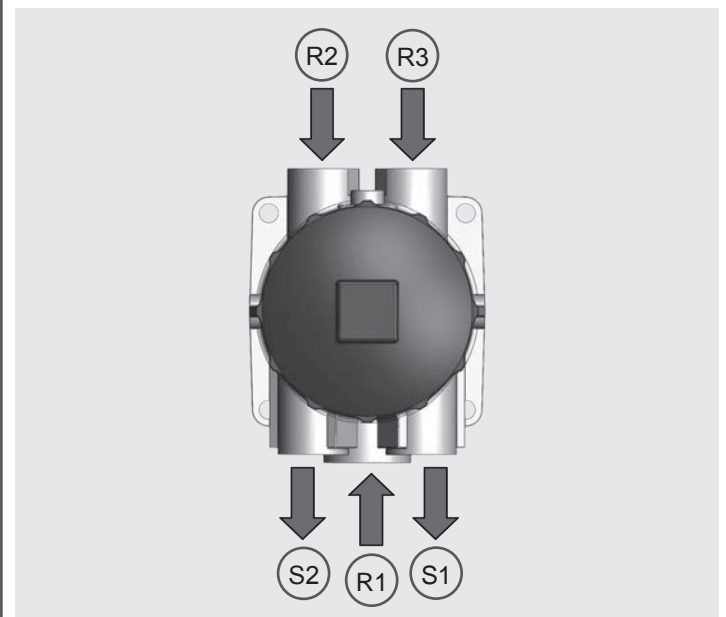
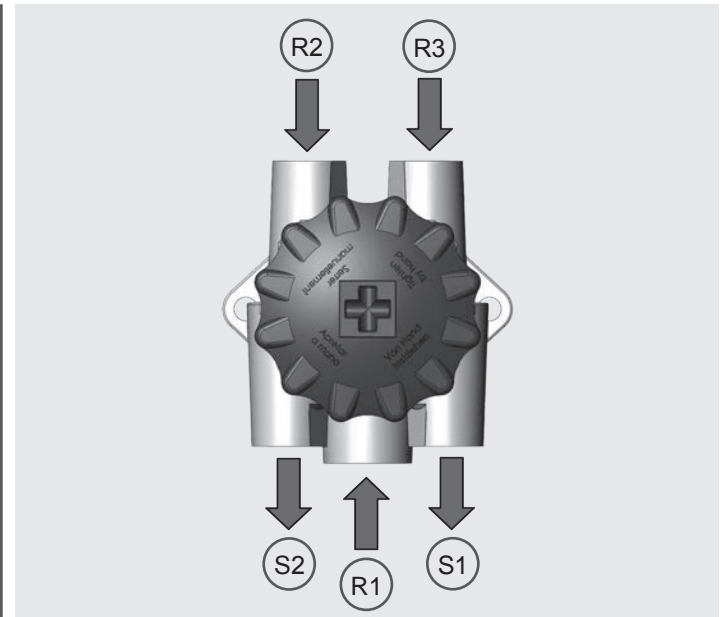

2.5 PORT CONFIGURATION RKM 151, 201, 251 WITH THERMAL BYPASS VALVE

The part flow which requires cooling can be directed via separate ports via the thermal valve. During a cold start, the spool of the thermal valve shuts off the flow to the cooler so that the fluid flows directly through the filter element. The position of the spool is regulated by the oil temperature. From approx. 50-60 °C the inlet to the cooler is completely open (diagram 1).

Alternative connection option according to diagram 2: A hose connects the inlet line of the cooler to the thermal valve. The connection configuration is determined by agreement with the customer.

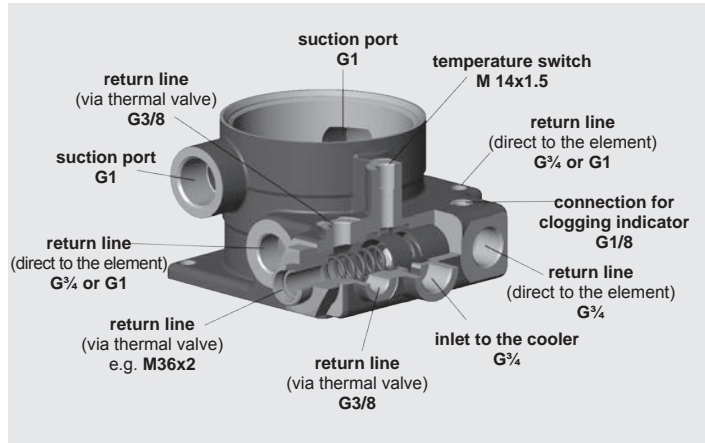

Diagram 1

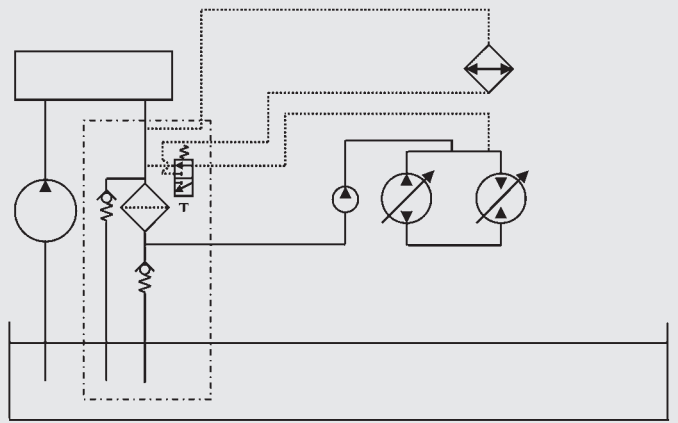
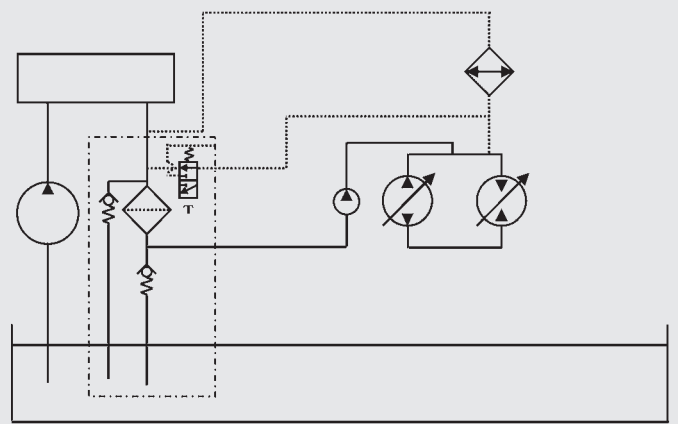
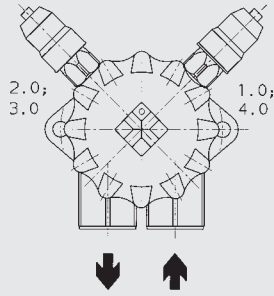

Diagram 2



2.6 TYPE CODE

RKM 80, 100, 120



RKM 151, 201, 251

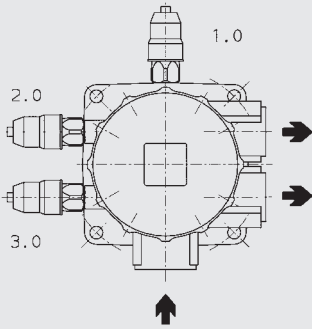

RKM 300

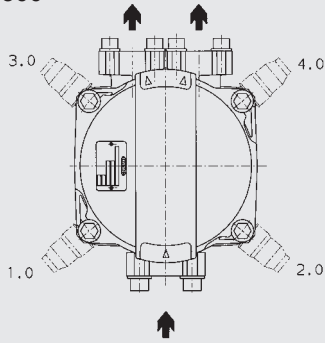

RKM 400, 800

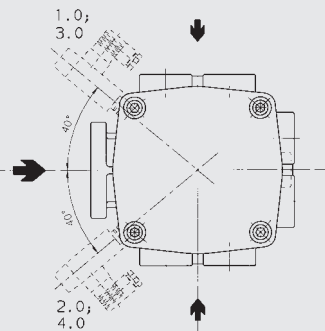

Type code	Type of clogging indicator	Measuring
1.X	Return line	Before filter element
2.X	Return line	Before filter element
3.X	Vacuum	After filter element
4.X	Vacuum	After filter element
5.X	2 indicators: Return line & vacuum	Before & after element

Type code	Type of clogging indicator	Measuring
1.X	Return line	Before filter element
2.X	Return line	Before filter element
3.X	Vacuum	After filter element
5.X	2 indicators: Return line & vacuum	Before & after element

Type code	Type of clogging indicator	Measuring
1.X	Return line	Before filter element
2.X	Return line	Before filter element
3.X	Vacuum	After filter element
4.X	Vacuum	After filter element
5.X	2 indicators: Return line & vacuum	Before & after element

Type code	Type of clogging indicator	Measuring
1.X	Return line	Before filter element
2.X	Return line	Before filter element
3.X	Vacuum	After filter element
4.X	Vacuum	After filter element
5.X	2 indicators: Return line & vacuum	Before & after element

Other indicator configurations on request!

2.7 SYMBOLS

/-NR

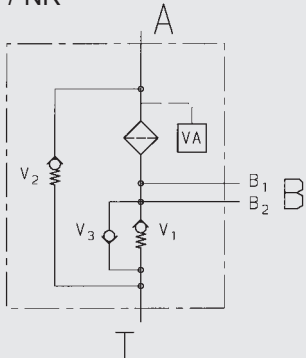

/-NRF125

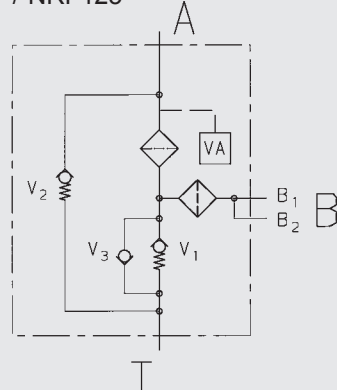

/-ND

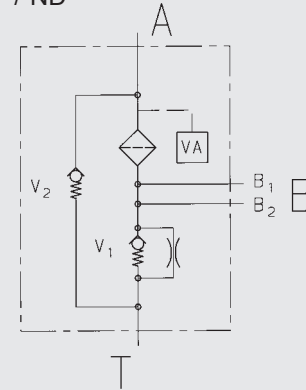

RKM 350

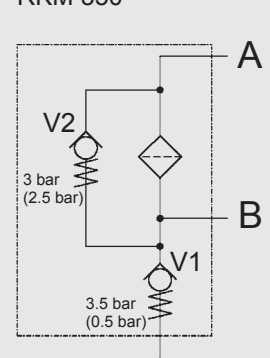

3. FILTER CALCULATION / SIZING

The total pressure drop of a filter at a certain flow rate Q is the sum of the housing Δp and the element Δp and is calculated as follows:

$$\Delta p_{\text{total}} = \Delta p_{\text{housing}} + \Delta p_{\text{element}}$$

$$\Delta p_{\text{housing}} = (\text{see Point 3.1})$$

$$\Delta p_{\text{element}} = Q \cdot \frac{SK^*}{1000} \cdot \frac{\text{viscosity}}{30}$$

(*see point 3.2)

For ease of calculation, our Filter Sizing Program is available on request free of charge.

NEW: Sizing online at www.hydac.com

3.1 GRADIENT COEFFICIENTS (SK) FOR FILTER ELEMENTS

The gradient coefficients in mbar/(l/min) apply to mineral oils with a kinematic viscosity of 30 mm²/s. The pressure drop changes proportionally to the change in viscosity.

RKM	MM		
	8 μm	10 μm	15 μm
80	2.70	2.70	1.60
100	1.80	1.80	1.10
120	1.40	1.40	0.90
151	1.00	1.00	0.65
201	0.75	0.75	0.47
251	0.58	0.58	0.36
300	0.62	0.62	0.39
350	0.30	0.30	0.20
400	0.56	0.56	0.35
800	0.44	0.44	0.27

3.2 Δp -Q HOUSING CURVES INCLUDING ELEMENT BASED ON ISO 3968

The housing curves apply to mineral oil with a density of 0.86 kg/dm³ and a kinematic viscosity of 30 mm²/s. In this case, the differential pressure changes proportionally to the density.

RKM 80

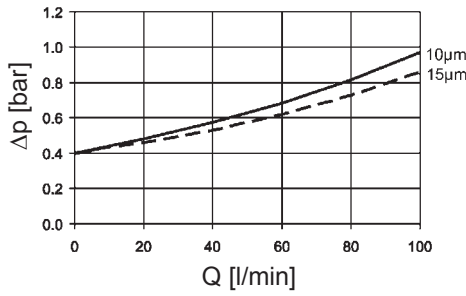

RKM 100

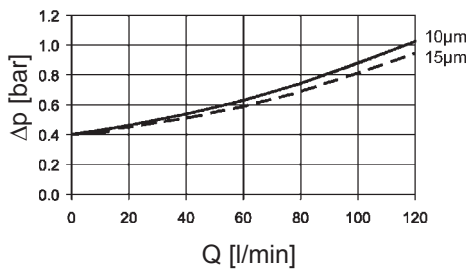

RKM 120

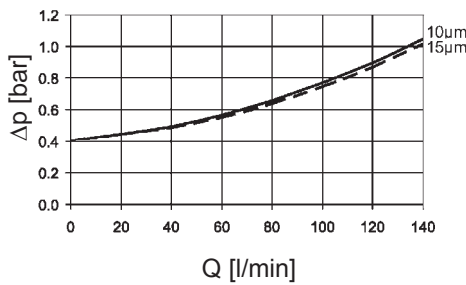

RKM 151

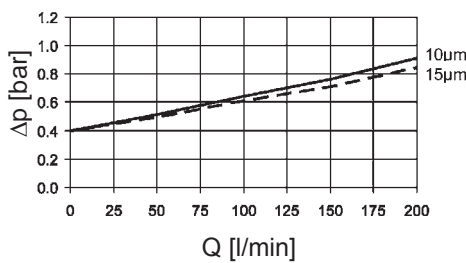

RKM 201

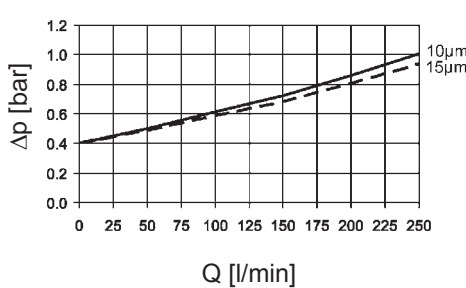

RKM 251

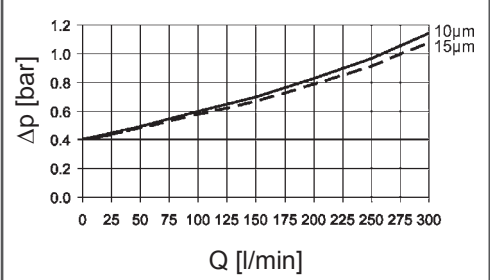

RKM 300

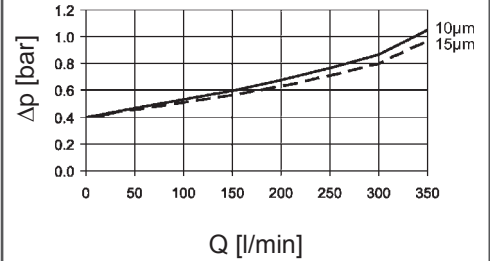

RKM 350

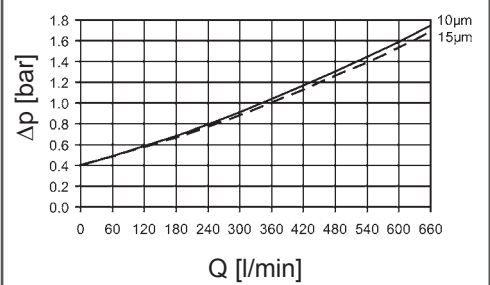

RKM 400

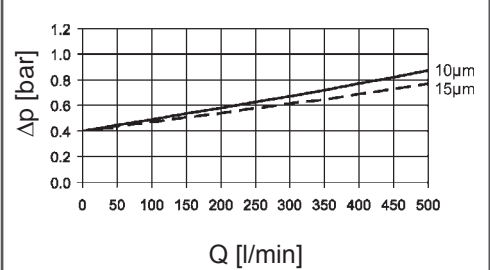

RKM 800

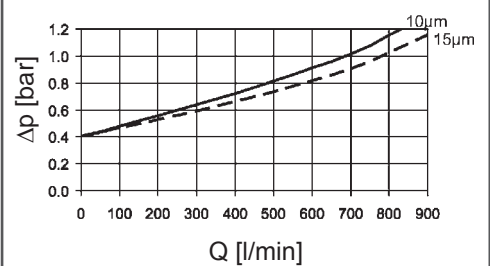

4. DIMENSIONS

RKM 80, 100, 120

Tank requirements

1. In the filter contact area, the tank flange should have a maximum flatness of 0.3 mm and Ra 3.2 µm maximum roughness.
2. In addition, the contact area should be free of damage and scratches.
3. The fixing holes of the tank flange must be blind, or stud bolts with threadlocker must be used to fix the filter.

As an alternative, the tank flange can be continuously welded from the inside.

4. Both the tank sheet metal and/or the filter mounting flange must be sufficiently robust so that neither deform when the seal is compressed during tightening.
5. When using a dipstick through a mounting screw, threadlock the screw into the thread, using Loctite 243, for example, or a similar threadlocker..

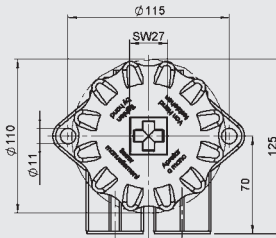
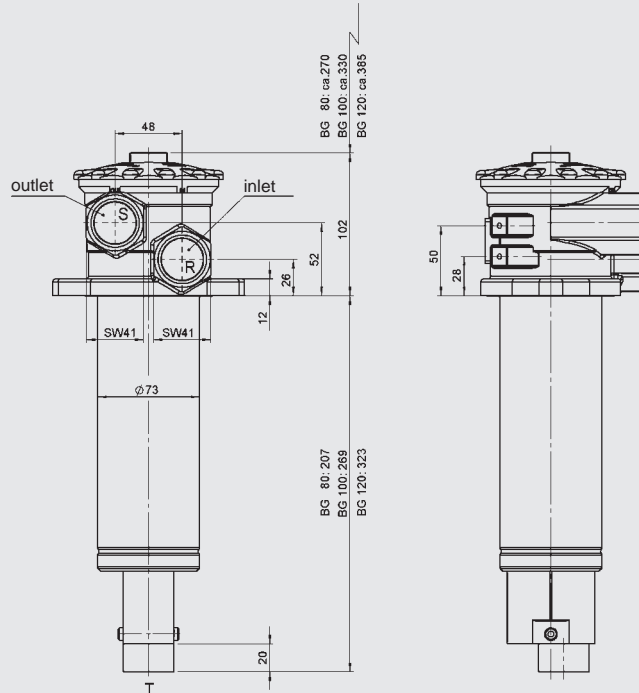

	Weight incl. element [kg]	Volume of pressure chamber [l]
RKM 80	1.5	0.80
RKM 100	1.7	1.00
RKM 120	1.9	1.20

RKM 80, 100, 120 Multiport

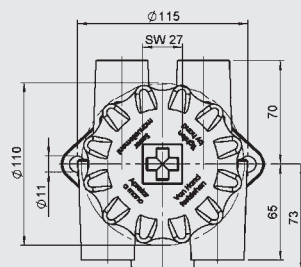
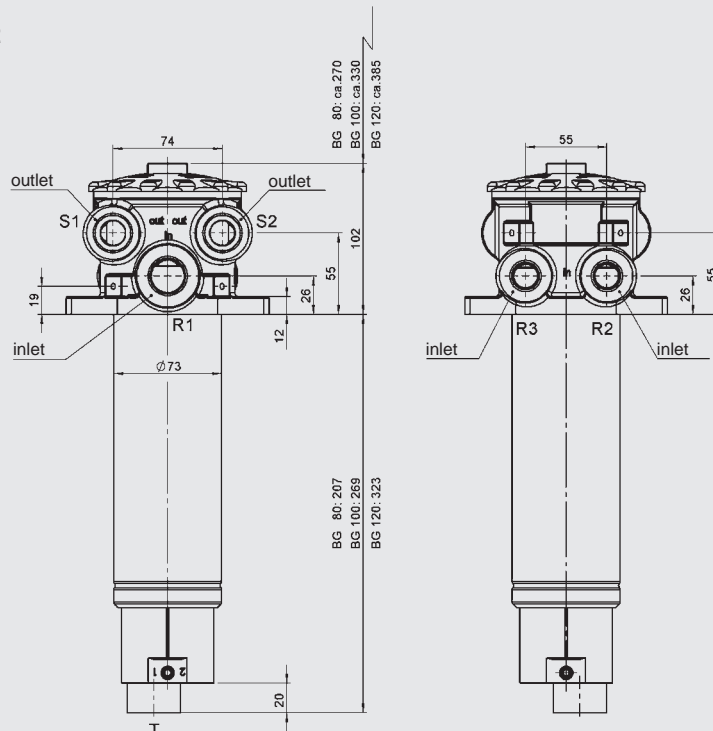

	Weight incl. element [kg]	Volume of pressure chamber [l]
RKM 80	1.8	0.80
RKM 100	2.0	1.00
RKM 120	2.2	1.20

RKM 151, 201, 251

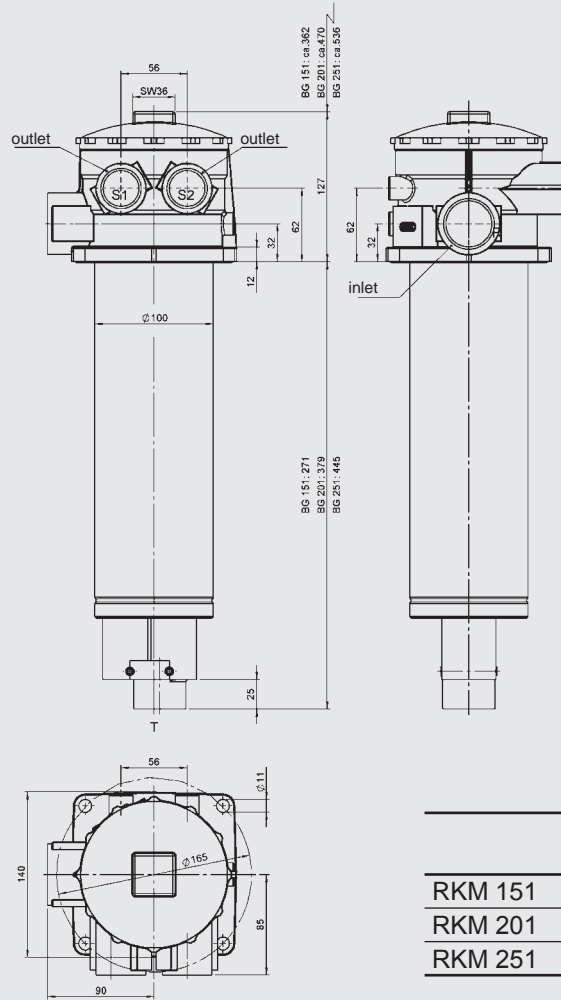

	Weight incl. element [kg]	Volume of pressure chamber [l]
RKM 151	3.1	2.20
RKM 201	3.7	2.50
RKM 251	4.0	3.00

RKM 151, 201, 251 Multiport

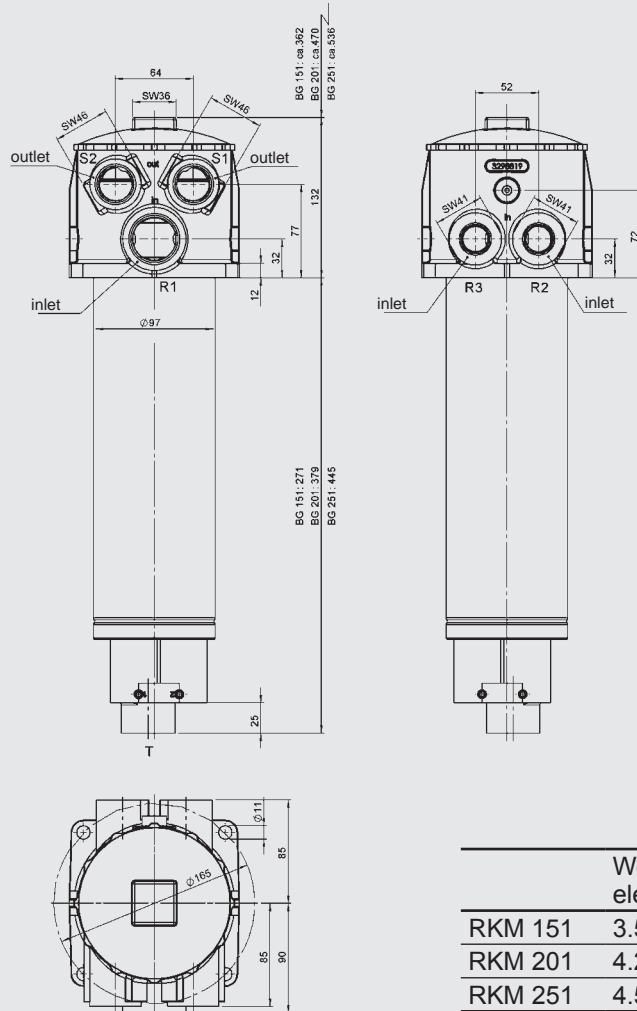

	Weight incl. element [kg]	Volume of pressure chamber [l]
RKM 151	3.5	2.20
RKM 201	4.2	2.50
RKM 251	4.5	3.00

RKM 151, 201, 251 with Thermal Bypass Valve

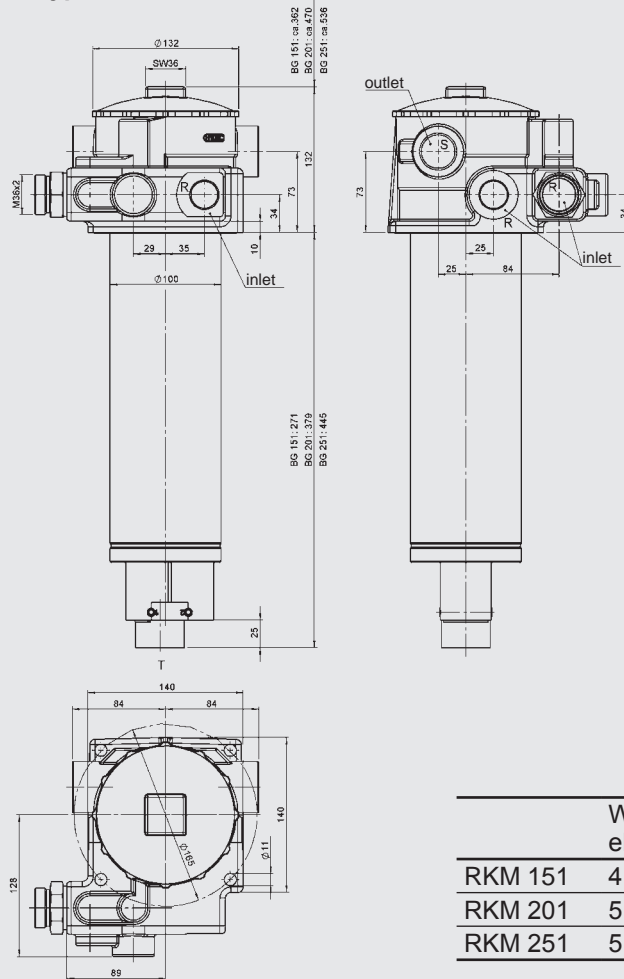

	Weight incl. element [kg]	Volume of pressure chamber [l]
RKM 151	4.6	2.20
RKM 201	5.2	2.50
RKM 251	5.5	3.00

RKM 300

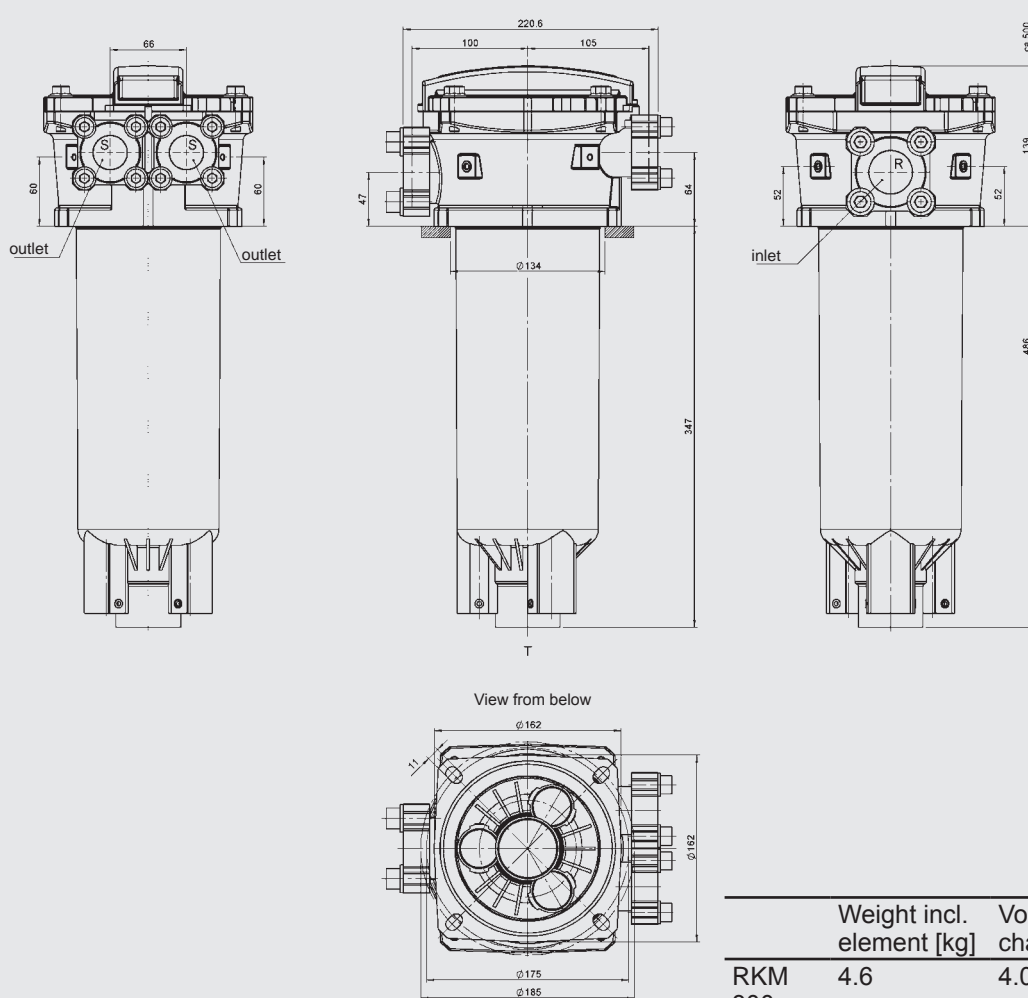

	Weight incl. element [kg]	Volume of pressure chamber [l]
RKM 300	4.6	4.00

RKM 350

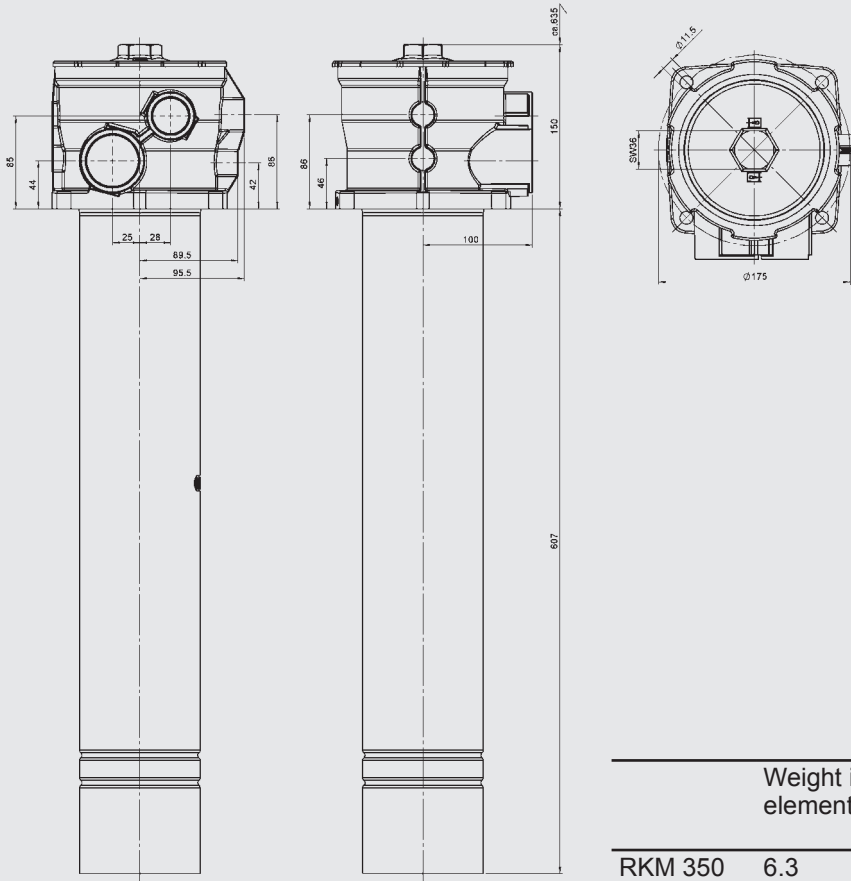

	Weight incl. element [kg]	Volume of pressure chamber [l]
RKM 350	6.3	6.00

RKM 400, 800

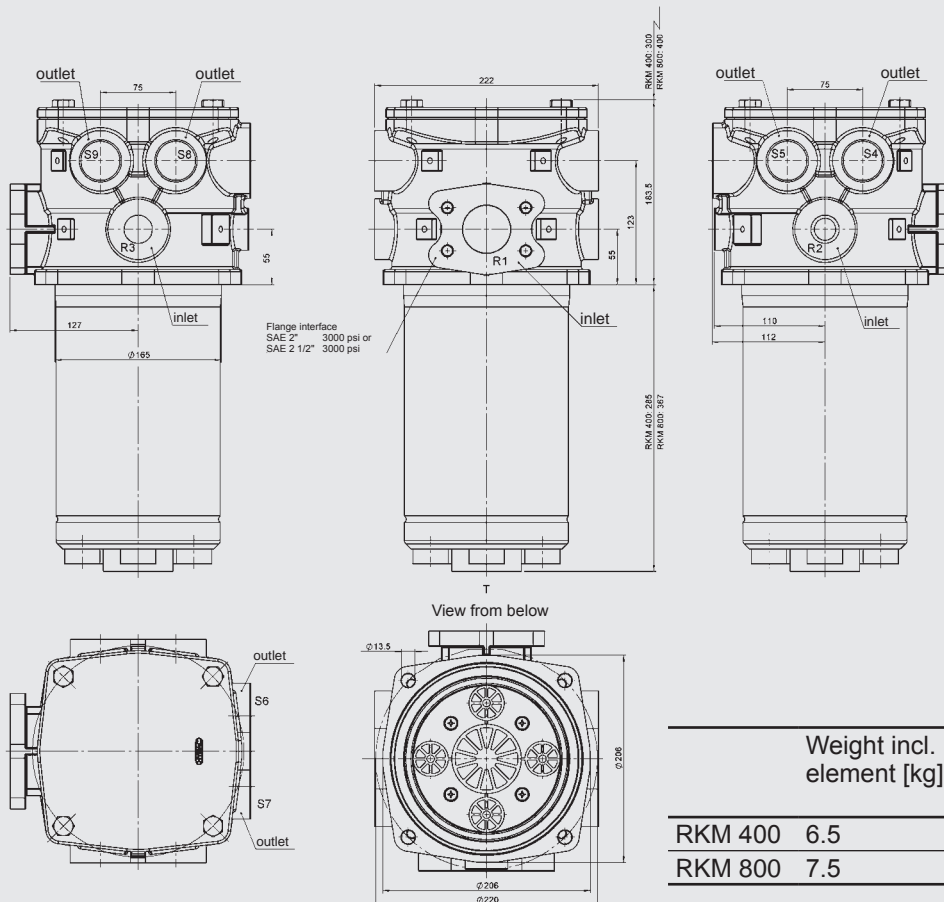

	Weight incl. element [kg]	Volume of pressure chamber [l]
RKM 400	6.5	8.50
RKM 800	7.5	10.00

NOTE

The information in this brochure relates to the operating conditions and applications described.
 For applications and operating conditions not described, please contact the relevant technical department.
 Subject to technical modifications.

HYDAC Filbertechnik GmbH
 Industriegebiet
D-66280 Sulzbach/Saar
 Tel.: 0 68 97 / 509-01
 Fax: 0 68 97 / 509-300
 Internet: www.hydac.com
 E-Mail: filter@hydac.com