

## MS-860-to-QX-870 Industrial Raster Scanner Transition Guide

The purpose of this document is to assist the user in transitioning from the **MS-860** to the **QX-870**.

MS-860 scanners have been used in a wide variety of applications, including food packaging, electronics manufacturing, automotive manufacturing, and other industrial environments. With the introduction of the **QX-870 Industrial Raster Scanner** and the **QX Platform**, applications that have used the MS-860 have the opportunity to simplify their connectivity, enhance their decode performance, and increase their configuration flexibility by upgrading to the new system.

**Important:** The QX-870 is not a drop-in replacement for the MS-860, although MS-860 mounting can be used.

The following procedure is a streamlined way of converting an application from the MS-860 to the QX-870.

1. Be sure that the version of **ESP Software** on the host computer is **ESP 5.2** or higher. ESP is available on the Microscan Tools CD and in the Download Center at [www.microscan.com](http://www.microscan.com).
2. Connect the **MS-860** to the host computer, open **ESP**, and **Receive Reader Settings** from the MS-860.

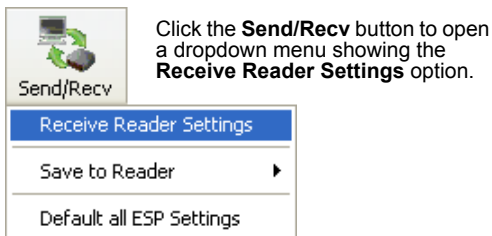

3. Navigate to the **Differences** tab in ESP's **Utilities** view and click the **Differences from Default** button. A list of commands will appear in a table below the Difference from Default button.

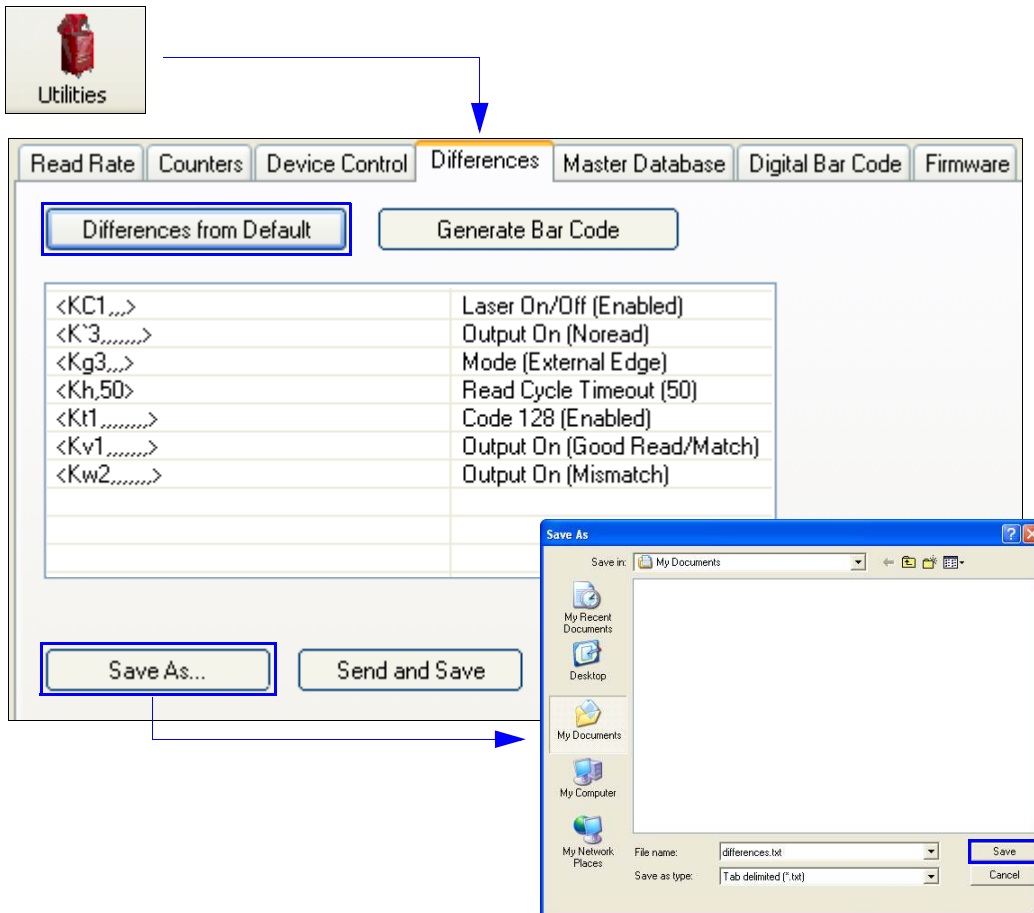

4. Click the **Save As** button below the Differences from Default command table, and select the **tab delimited (\*.txt)** file type when the Windows **Save As** dialog appears. Select the preferred location for the file on the host hard drive and click **Save**.

MS-860-to-QX-870 Industrial Raster Scanner Transition Guide

- Remove power and physically disconnect the MS-860, physically connect the **QX-870**, reapply power using the QX-870 power supply, then **Switch Model** in ESP and select the QX-870 from the model menu.

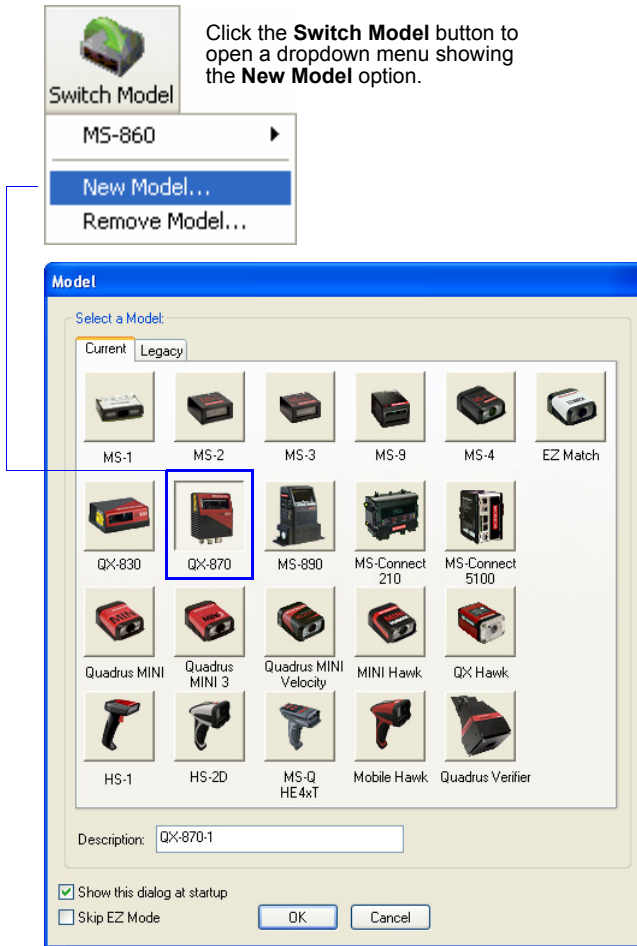

- Autoconnect to the QX-870.

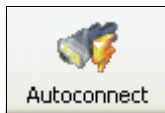

- Match the command settings in ESP's QX-870 tree controls to the list of commands in the tab delimited file that was created in Step 4. Refer to the [MS-860-to-QX-870 Command Comparisons](#) table for a list of command equivalents between the MS-860 and QX-870.

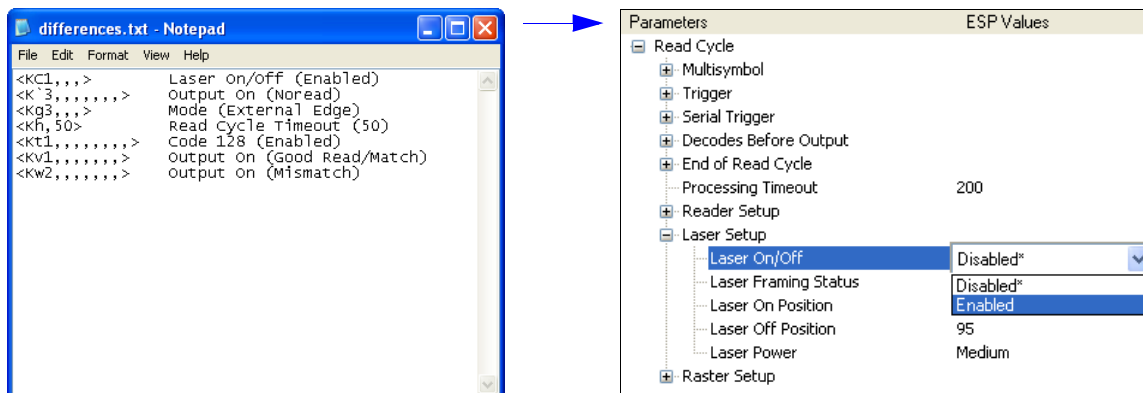

Tab Delimited Text File with MS-860 Differences from Default Settings

QX-870 ESP Tree Control

*MS-860-to-QX-870 Industrial Raster Scanner Transition Guide*

8. Once all the command settings shown in the tab delimited text file are matched in ESP's tree controls, **Send and Save** the settings to the QX-870.

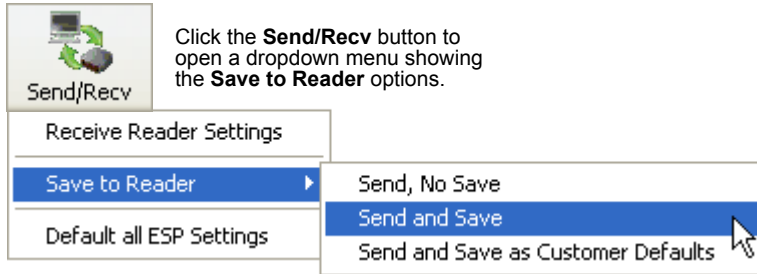

9. Make additional configuration changes to the QX-870 as required by the application. Refer to the *QX-870 Industrial Raster Scanner User's Manual* for detailed information about scanner configuration.

For further assistance with any part of the MS-860 to QX-870 conversion process, contact your Microscan Partner or the Microscan Help Desk:

helpdesk@microscan.com

+1.425.203.4841 / +1.800.251.7711

MS-860-to-QX-870 Industrial Raster Scanner Transition Guide

**MS-860-to-QX-870 Command Comparisons**

The following table shows MS-860 commands on the left and QX-870 commands on the right. The name of the command is shown first, and the parameters are shown to the right of the name.

Commands that have remained equivalent or near-equivalent from MS-860 to QX-870 are shown directly opposite each other. Some MS-860 commands are not present in the QX-870, and some QX-870 commands are new. This is indicated with gray boxes.

MS-860 Commands		QX-870 Commands	
<b>MS-860 Communications</b>		<b>QX-870 Communications</b>	
Host Port Connections	<K100,baud rate,parity,stop bits,data bits>	RS-232 A	<K100,baud rate,parity,stop bits,data bits>
Auxiliary Port	<K101,aux port mode,baud rate,parity,stop bits,data bits,daisy chain status,daisy chain ID>	RS-232 B	<K101,status,baud rate,parity,stop bits,data bits>
		RS-422	<K102,status,baud rate,parity,stop bits,data bits>
		Ethernet	<K126,status,IP address,subnet,gateway,IP address mode>
		Ethernet TCP Ports	<K127,TCP Port 1,TCP Port 2>
		EtherNet/IP	<K129,status>
		RS-232 A Data Type	<K130,symbol data output,extra symbol information,diagnostic output, external source processing mode>
		RS-232 B Data Type	<K131,symbol data output,extra symbol information,diagnostic output, external source processing mode>
		RS-422 Data Type	<K132,symbol data output,extra symbol information,diagnostic output, external source processing mode>
		Ethernet TCP Port 1 Data Type	<K133,symbol data output,extra symbol information,diagnostic output, external source processing mode>
		Ethernet TCP Port 2 Data Type	<K134,symbol data output,extra symbol information,diagnostic output, external source processing mode>
		EtherNet/IP Data Type	<K136,symbol data output,extra symbol information,diagnostic output, external source processing mode>
Host Protocol	<K140,protocol>		
Preamble	<K141,status,preamble>	Preamble	<K141,status,preamble>
Postamble	<K142,status,postamble>	Postamble	<K142,status,postamble>
Response Timeout	<K143,response timeout>	Response Timeout	<K143,response timeout>
LRC Status	<K145,status>	LRC Status	<K145,status>
Auxiliary Port System Status	<K146,aux status>		
		ACK/NAK Options	<K147,RES,REQ,STX,ETX,ACK,NAK>
		Polling Mode Options	<K148,RES,REQ,STX,ETX,ACK,NAK>
Autoconfiguration Daisy Chain	<K150DAISY>	Autoconfiguration Daisy Chain	<K150DAISY>
Daisy Chain Scanner ID	<K151,daisy chain scanner,daisy chain scanner ID>		
		Protocol Selection	<K160,protocol,address,protocol port>
		External Data Routing	<K161,mode,destination port,ambles to source,echo to source,output at end of read cycle,output at ETX,output at timeout>
		Array Communication Modes	<K162,mode,source,daisy chain ID status,daisy chain ID>

MS-860-to-QX-870 Industrial Raster Scanner Transition Guide

<b>MS-860 Read Cycle</b>		<b>QX-870 Read Cycle</b>	
Trigger Mode / Trigger Filter Duration	<K200,trigger mode,trigger filter duration>	Trigger Mode / Trigger Filter Duration	<K200,trigger mode,leading edge trigger filter duration,trailing edge trigger filter duration>
Serial Trigger Character	<K201,serial trigger character>	Serial Trigger Character	<K201,serial trigger character>
External Trigger State	<K202,external trigger state>	External Trigger State	<K202,external trigger state>
End of Read Cycle	<K220,mode,read cycle timeout>	End of Read Cycle	<K220,mode,read cycle timeout>
Decodes Before Output	<K221,number before output, decodes before output mode>	Decodes Before Output	<K221,mode,number before output>
Multisymbol	<K222,number of symbols, multisymbol separator>	Multisymbol	<K222,number of symbols, multisymbol separator>
Serial Trigger Start Character	<K229,start character>	Serial Trigger Start Character	<K229,start character>
Serial Trigger Stop Character	<K230,stop character>	Serial Trigger Stop Character	<K230,stop character>
		Processing Timeout	<K245,processing timeout>
Motor On	<K500,scan speed>	Scan Speed	<K500,scan speed>
Motor Off	<K501,motor off>	Motor Off	<K501,motor off>
Maximum Element	<K502,maximum element>	Maximum Element	<K502,maximum element>
Automatic Gain Control	<K504,gain level,AGC sampling mode,AGC minimum,AGC maximum>	Automatic Gain Control	<K504,gain level,AGC sampling mode,AGC minimum,AGC maximum>
Symbol Detect Status / Transition Counter	<K505,symbol detect status, transition counter>	Symbol Detect Status / Transition Counter	<K505,symbol detect status, transition counter>
Raster Framing	<K506,status,top offset,bottom offset,sweep rate,read cycle on/off>	Raster Framing	<K506,status,top offset,bottom offset,sweep rate,read cycle on/off>
		Scan Width Enhance	<K511,status>
AGC Tracking	<K520,tracking>	AGC Tracking	<K520,tracking>
Laser Setup	<K700,laser on/off,laser framing status,laser on position,laser off position,laser power>	Laser Setup	<K700,laser on/off,laser framing status,laser on position,laser off position,laser power>
<b>QX-870 Configuration Database</b>		<b>QX-870 Configuration Database</b>	
Database Operation	<K252,number of active indexes, database cycles>	Number of Active Indexes	<K252,number of active indexes, number of database cycles>
Database Setup	<K253,index,gain,AGC mode, tracking,raster top,raster bottom, raster speed,laser framing status, laser on position,laser off position, laser power,background color>	Configuration Database	<K253,index,gain,AGC mode, tracking,raster top,raster bottom, raster speed,laser framing status, laser on position,laser off position, laser power,background color>
Database Mode	<K254,mode,count/time>	Switch Timing	<K254,switch mode,time>
<b>MS-860 Symbolgies</b>		<b>QX-870 Symbolgies</b>	
Narrow Margins / Symbology Identifier	<K450,narrow margins status, symbology identifier>	Quiet Zone	<K450,quiet zone status>
Background Color	<K451,background color>	Background Color	<K451,background color>
		Symbol Ratios	<K452,Code 39,Codabar, Interleaved 2 of 5>
Composite	<K453,symbology status,separator status,separator>	Composite	<K453,symbology status,separator status,separator>
AIAG	<K454,status,ID1,status1, ID2,status2,ID3,status3,ID4, status4,ID5a,ID5b,ID5c,status5, ID6,status6,ID7,status7,ID8, status8,ID9,status9,ID10,status10, ID11,status11,ID12,status12>	AIAG	<K454,status,ID1,status1, ID2,status2,ID3,status3,ID4, status4,ID5a,ID5b,ID5c,status5, ID6,status6,ID7,status7,ID8, status8,ID9,status9,ID10,status10, ID11,status11,ID12,status12>
		Depth of Field Enhance	<K456,DOF Enhance mode>
Code 39	<K470,status,check character status, check character output status,large intercharacter gap,fixed symbol length status,fixed symbol length,full ASCII set>	Code 39	<K470,status,check character status, check character output status,large intercharacter gap,fixed symbol length status,fixed symbol length,full ASCII set>

MS-860-to-QX-870 Industrial Raster Scanner Transition Guide

<b>MS-860 Symbolologies (continued)</b>		<b>QX-870 Symbolologies (continued)</b>	
Codabar	<K471,status,start/stop match status,start/stop output status,large intercharacter gap,fixed symbol length status,fixed symbol length,check character type,check character output status>	Codabar	<K471,status,start/stop match status,start/stop output status,large intercharacter gap,fixed symbol length status,fixed symbol length,check character type,check character output status>
Interleaved 2 of 5	<K472,status,check character status,check character output status,symbol length 1,symbol length 2,guard bar,range mode status>	Interleaved 2 of 5	<K472,status,check character status,check character output status,symbol length 1,symbol length 2,guard bar,range mode status>
UPC/EAN	<K473,mode,EAN status,supplementals status,separator status,separator character,supplementals type,UPC-E as UPC-A>	UPC/EAN	<K473,mode,EAN status,supplementals status,separator status,separator character,supplementals type,UPC-E as UPC-A>
Code 128 / EAN 128	<K474,status,fixed symbol length status,fixed symbol length,EAN status,output format,application record separator status,application record separator character,application record brackets,application record padding,separation factor>	Code 128 / EAN 128	<K474,status,fixed symbol length status,fixed symbol length,EAN status,output format,application record separator status,application record separator character,application record brackets,application record padding,separation factor>
Code 93	<K475,mode,fixed symbol length status,symbol length>	Code 93	<K475,mode,fixed symbol length status,symbol length>
PDF417	<K476,status,scan line limit,fixed symbol length status,fixed symbol length,decode at end of read cycle>	PDF417	<K476,status,raster sweep count, fixed symbol length status, fixed symbol length,unused,codeword collection>
Pharmacode	<K477,status,fixed bar count status,fixed bar count,minimum bar count,bar width mode,direction,fixed threshold value>	Pharmacode	<K477,status,fixed bar count status,fixed bar count,minimum bar count,bar width mode,direction,fixed threshold value>
DataBar Omnidirectional (RSS-14)	<K482,status>	DataBar Omnidirectional (RSS-14)	<K482,status>
DataBar Limited (RSS Limited)	<K483,status>	DataBar Limited (RSS Limited)	<K483,status>
DataBar Expanded (RSS Expanded)	<K484,status,fixed symbol length status,fixed symbol length>	DataBar Expanded (RSS Expanded)	<K484,status,fixed symbol length status,fixed symbol length>
MicroPDF417	<K485,status,scan line limit,fixed symbol length status,fixed symbol length>	MicroPDF417	<K485,status,scan line limit,fixed symbol length status,fixed symbol length>
		Symbol Reconstruction	<K496,symbol reconstruction redundancy,symbol reconstruction effort>
<b>MS-860 I/O Parameters</b>		<b>QX-870 I/O Parameters</b>	
Calibration Options	<K521,raster options,video status,scan speed status,laser power status,laser framing status,symbology detect>	Calibration Options	<K521,raster framing,video,scan speed,laser power,laser framing,symbology>
Serial Verification	<K701,serial command echo status,serial command beep status,control/hex output>	Serial Verification	<K701,serial command echo status,serial command beep status,control/hex output>
Beeper	<K702,beeper output>	Beeper	<K702,status>
Quality Output	<K704,quality output separator,decodes/trigger status,decode direction output>	Quality Output	<K704,quality output separator,decodes/trigger status,decode direction output>
Symbol Data Output	<K705,symbol data output status,when to output>	Symbol Data Output	<K705,symbol data output status,when to output symbol data,symbology identifier status>
Read Duration Output	<K706,status,separator>	Read Duration Output	<K706,status,separator>
No Read Message	<K714,status,message>	No Read Message	<K714,status,message>
Bad Symbol Message	<K715,status,message>	Bad Symbol Message	<K715,status,message>
No Symbol Message	<K716,status,message>	No Symbol Message	<K716,status,message>
Input 1	<K730,input mode,active state>	Input 1	<K730,input mode,active state>
Output Indicators	<K750,green flash mode,unused,green flash duration>	Green Flash LED	<K750,green flash mode,unused,green flash duration>

*MS-860-to-QX-870 Industrial Raster Scanner Transition Guide*

<b>MS-860 I/O Parameters (continued)</b>		<b>QX-870 I/O Parameters (continued)</b>	
		Status Indicators	<K751,status,bar graph,I/O 1,I/O 2>
Symbol Position Output	<K758,raster status,scan status,separator>	Symbol Position Output	<K758,raster position output status,scan position output status,separator>
Database Identifier Output	<K759,status,separator>	Database Identifier Output	<K759,status,separator character>
EZ Button	<K770,global status,default on power-on>	EZ Button	<K770,status,default on power-on>
EZ Button Modes	<K771,position 1 mode[0-9],position 2 mode[0-9],position 3 mode[0-9]>	EZ Button Modes	<K771,single beep,two beeps,three beeps,four beeps>
Auto Framing Options	<K773,raster status,laser status>	Auto Framing Options	<K773,laser framing>
Trend Analysis Output 1	<K780,trend analysis mode,number of triggers,number to output on,decodes per trigger>	Trend Analysis Output 1	<K780,trend analysis mode,number of triggers,number to output on,decodes per trigger>
Trend Analysis Output 2	<K781,trend analysis mode,number of triggers,number to output on,decodes per trigger>	Trend Analysis Output 2	<K781,trend analysis mode,number of triggers,number to output on,decodes per trigger>
Trend Analysis Output 3	<K782,trend analysis mode,number of triggers,number to output on,decodes per trigger>	Trend Analysis Output 3	<K782,trend analysis mode,number of triggers,number to output on,decodes per trigger>
Diagnostics Output 1	<K790,high temperature,service unit,unused,laser current high,laser current low,low temperature>	Diagnostics Output 1	<K790,high temperature,service unit,unused,laser current high,laser current low,low temperature>
Diagnostics Output 2	<K791,high temperature,service unit,unused,laser current high,laser current low,low temperature>	Diagnostics Output 2	<K791,high temperature,service unit,unused,laser current high,laser current low,low temperature>
Diagnostics Output 3	<K792,high temperature,service unit,unused,laser current high,laser current low,low temperature>	Diagnostics Output 3	<K792,high temperature,service unit,unused,laser current high,laser current low,low temperature>
Output 1 Parameters	<K810,output on,output state,pulse width,output mode>	Output 1 Parameters	<K810,output on,output state,pulse width,output mode>
Output 2 Parameters	<K811,output on,output state,pulse width,output mode>	Output 2 Parameters	<K811,output on,output state,pulse width,output mode>
Output 3 Parameters	<K812,output on,output state,pulse width,output mode>	Output 3 Parameters	<K812,output on,output state,pulse width,output mode>
<b>MS-860 Matchcode</b>		<b>QX-870 Matchcode</b>	
Matchcode	<K223,matchcode type,sequential matching,match start position,match length,wild card,sequence on no read,sequence on mismatch>	Matchcode	<K223,matchcode type,sequential matching,match start position,match length,wild card,sequence on no read,sequence on mismatch>
Master Symbol Database Size	<K224,number of master symbols>	Master Symbol Database Size	<K224,number of master symbols>
New Master Pin	<K225,status>	New Master Pin	<K225,status>
Sequence Step	<K228,sequence step>	Sequence Step	<K228,sequence step>
Master Symbol	<K231,master symbol number, master symbol data>	Master Symbol	<K231,index,master symbol data>
Match Replace	<K735,status,replacement string>	Match Replace	<K735,status,replacement string>
Mismatch Replace	<K736,status,replacement string>	Mismatch Replace	<K736,status,replacement string>
<b>MS-860 Diagnostics</b>		<b>QX-870 Diagnostics</b>	
Warning Messages	<K400,warning message status,laser high status,laser low status,NOVRAM/reset warning status>		
High Temperature Threshold	<K402,status,message>	High Temperature Threshold	<K402,status,message>
Low Temperature Threshold	<K403,status,message>	Low Temperature Threshold	<K403,status,message>
Counts (Read-only)	<K406> (returns: power-on, resets, power-on saves, custom default saves)	Counts (Read-only)	<K406> (returns: power-on, resets, power-on saves, custom default saves)
Hours Since Reset (Read-only)	<K407> (returns: hours, minutes)	Hours Since Reset (Read-only)	<K407> (returns: hours, minutes)
Service Message	<K409,status,service message, threshold,resolution>	Service Message	<K409,status,service message, threshold,resolution>

*MS-860-to-QX-870 Industrial Raster Scanner Transition Guide*

<b>MS-860 Diagnostics (continued)</b>		<b>QX-870 Diagnostics (continued)</b>	
Laser Current Warning Message	<K411,laser high status,laser high message,laser low status,laser low message>	Laser Current Warning Message	<K411,laser high status,laser high message,laser low status,laser low message>
		User-Defined Name	<K412,user-defined name>
<b>QX-870 Output Format</b>		<b>QX-870 Output Format</b>	
Format Extract	<K740,output index,start position,length>	Format Extract	<K740,output index,start location,length>
Format Insert	<K741,output index,length,hex string>	Format Insert	<K741,output index,length,hex string>
Format Assign	<K742,symbol number,status>	Format Assign	<K742,symbol number,status>
Format Status	<K743,output format status>	Format Status	<K743,output format status>
Output Filter Configuration	<K744,filter index,symbology,length,wildcard,placeholder,data,decode direction,check database number>	Output Filter Configuration	<K744,filter number,symbology,length,wildcard,placeholder,data,decode direction,database index>
Output Filter Enable	<K745,number of filters>	Output Filter Enable	<K745,number of filters>



MS-860-to-QX-870 Industrial Raster Scanner Transition Guide

## Alpha Commands Supported in the QX-870

The following table shows alpha commands that will function in the QX-870. The QX-870 is intended for use with numeric commands, but the commands shown below can be used.

**Important:** Microscan does not guarantee support for these commands in future versions of the QX-870.

Alpha Commands		Numeric
<b>Communications</b>		
Host Port Connections	<K <b>a</b> baud rate,parity,stop bits,data bits>	<K100>
Auxiliary Port	<K <b>y</b> aux port mode,baud rate,parity,stop bits,data bits,daisy chain status,daisy chain ID>	<K101>
Preamble	<K <b>d</b> status,preamble>	<K141>
Postamble	<K <b>e</b> status,postamble>	<K142>
Response Timeout	<K <b>A</b> response timeout>	<K143>
LRC Status	<K <b>c</b> status>	<K145>
<b>Read Cycle</b>		
Trigger Mode	<K <b>g</b> trigger mode,filter time>	<K200>
Serial Trigger Character	<K <b>i</b> serial trigger character>	<K201>
External Trigger State	<K <b>j</b> external trigger state>	<K202>
End of Read Cycle	<K <b>h</b> mode,read cycle timeout>	<K220>
Good Decode Reads	<K <b>m</b> good decode reads>	<K221>
Multisymbol	<K <b>L</b> number of symbols,multisymbol separator>	<K222>
Motor On/Scan Speed	<K <b>E</b> >	<K500>
Motor Off	<K <b>F</b> >	<K501>
Maximum Element	<K <b>I</b> maximum element>>	<K502>
Laser Controls	<K <b>C</b> laser on/off,laser framing status,laser on position,laser off position>	<K700>
<b>Symbologies</b>		
Narrow Margins / Symbology Identifier	<K <b>o</b> narrow margins,symbology identifier status>	<K450>
Background Color	<K <b>x</b> background color>	<K451>
AIAG	<K <b>Z</b> status,ID1,status1,ID2,status2,ID3,status3,ID4,status4,ID5a,ID5b,ID5c,status5,ID6,status6,ID7,status7,ID8,status8,ID9,status9,ID10,status10,ID11,status11,ID12,status12>	<K454>
Code 39	<K <b>p</b> status,check digit status,check digit output status,large intercharacter gap,fixed symbol length status,fixed symbol length,full ASCII set>	<K470>
Codabar	<K <b>q</b> status,start and stop match status,start and stop output status,large intercharacter gap,fixed symbol length status,symbol length,check digit type,check digit output>	<K471>
Interleaved 2 of 5	<K <b>r</b> status,check digit status,check digit output,symbol length 1,symbol length 2>	<K472>
UPC/EAN	<K <b>s</b> UPCstatus,EAN status,supplementals status,separator status,separator character>	<K473>
Code 128 / EAN 128	<K <b>t</b> status,fixed symbol length status,fixed symbol length,EAN-128 status,output format,application record separator status,application record separator character,application record brackets,application record padding>	<K474>
Code 93	<K <b>l</b> status,fixed symbol length status,symbol length>	<K475>
PDF417	<K <b>j</b> status,raster sweeps before decode attempt,fixed length status,symbol length>	<K476>
<b>I/O Parameters</b>		
Serial Verification	<K <b>S</b> command echo status,command beep status,control/hex output>	<K701>
Beeper	<K <b>u</b> status,volume>	<K702>
Quality Output	<K <b>J</b> quality output separator,decodes/trigger status,decode direction output>>	<K704>
Symbol Data Output	<K <b>I</b> symbol data output status,when to output>	<K705>
No Read Message	<K <b>k</b> status,message>	<K714>
Bad Symbol Message	<K' status,message>	<K715>
No Symbol Message	<K <b>N</b> status,message>	<K716>

*MS-860-to-QX-870 Industrial Raster Scanner Transition Guide*

<b>Alpha Commands</b>		<b>Numeric</b>
<b>Matchcode</b>		
Matchcode	< <b>K</b> <i>n</i> matchcode type,sequential matching,match start position,match length,wildcard character,sequence on noread,sequence on mismatch>	< <b>K223</b> >
Master Symbol Database Size	< <b>K</b> <i>M</i> number of master symbols>	< <b>K224</b> >
New Master Pin	< <b>K</b> <i>z</i> status>	< <b>K225</b> >
<b>Diagnostics</b>		
High Temperature Threshold	< <b>K</b> <i>+</i> degrees,message>	< <b>K402</b> >
Low Temperature Threshold	< <b>K</b> <i>-</i> degrees,message>	< <b>K403</b> >
Counts (Read-only)	< <b>K</b> <i>_?</i> > (returns: power-ons,resets)	< <b>K406</b> >
Hours Since Reset (Read-only)	< <b>K</b> <i>@?</i> > (returns: hours,minutes)	< <b>K407</b> >

MS-860-to-QX-870 Industrial Raster Scanner Transition Guide

### MS-860 and QX-870 Connectivity

There are significant hardware and connectivity differences between the MS-860 and QX-870. The diagrams and parts list below demonstrate the difference between MS-860 and QX-870 hardware configuration.

**Note:** For other configurations, such as multidrop and daisy chain, refer to the configuration guides and user's manuals for the MS-860 and QX-870.

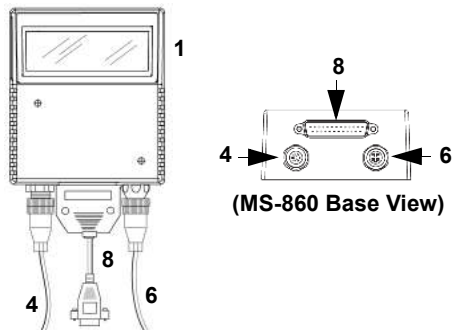

**MS-860 Standalone**

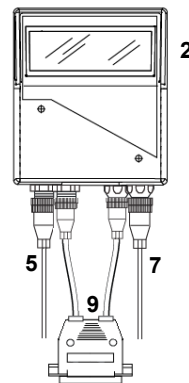

**QX-870 Serial Standalone with 61-000172-01 Cordset**

The QX-to-DB25 cordset (9) can be connected to host or communication cable (8).

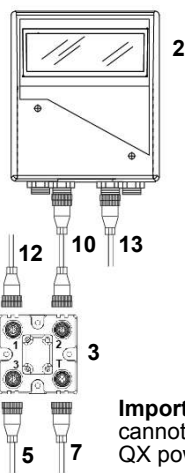

**Important:** The MS-860 power supply (4) cannot be used with the QX-870. Use the QX power supply (5).

**QX-870 Standalone (Serial or Ethernet) with QX-1**

Item	Description	Part Number
1	MS-860 Industrial Laser Scanner	FIS-0860-XXXXG
2	QX-870 Industrial Raster Scanner	FIS-0870-XXXXG
3	QX-1 Interface Device	98-000103-01
4	Power Supply, 90-254 VAC, 24VDC, USA/Euro plug	97-100004-15
5	QX Power Supply, 90-254 VAC, M12 12-pin socket, 1.3 m	97-000003-01
6	Object Detector Photo Sensor, Visible, NPN, Dark On	99-000017-01
7	QX Photo Sensor, M12 4-pin Plug, NPN, Dark On, 2 m	99-000020-02
8	Communication Cable, 25-pin plug to 9-pin socket, 6 ft.	61-300026-03
9	QX Cordset, M12 12-pin plug and M12 12-pin socket to DB25 socket, 2 m	61-000172-01
10	QX Cordset, Common, M12 12-pin plug to M12 12-pin socket, 1 m	61-000162-01
11	QX Cordset, Host, Serial, M12 12-pin plug to DB9 socket, 1 m (not shown)	61-000152-01
12	QX Cordset, Host, Serial, M12 12-pin socket to DB9, 1 m	61-000153-01
13	QX Cordset, Host, Ethernet, M12 8-pin plug to RJ45, 1 m	61-000160-01
14	QX Cordset, M12 12-pin plug to MS-Connect 5100, 3 m (not shown)	61-000161-01
15	QX Cordset, M12 12-pin plug/M12 12-pin socket to MS-Connect 210, RS-232, 2 m (not shown)	61-000158-03
16	QX Cordset, M12 12-pin plug/M12 12-pin socket to MS-Connect 210, RS-422/485, 2 m (not shown)	61-000158-04

MS-860-to-QX-870 Industrial Raster Scanner Transition Guide

**MS-860 and QX-870 Specifications**

**Mechanical**

The mounting dimensions of the MS-860 and QX-870 are essentially the same, although the M12 receptacles at the base of the QX-870 may affect installation in some applications.

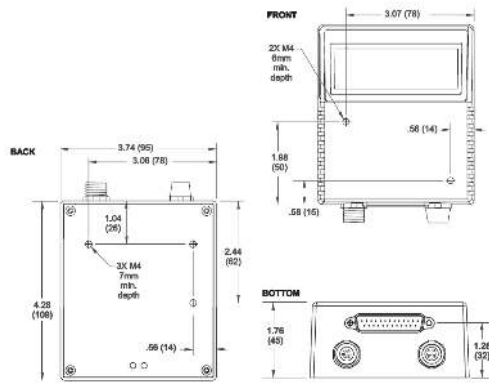

MS-860 Dimensions

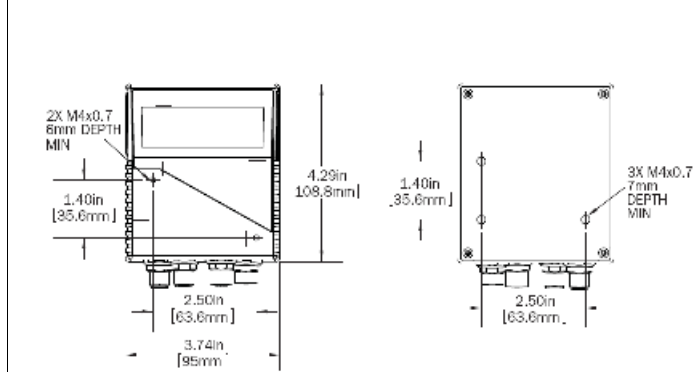

QX-870 Dimensions

**Environmental**

MS-860		QX-870	
Enclosure	IP65 rated	Enclosure	IP65 rated
Operating Temperature	0° to 50° C (32° to 122° F)	Operating Temperature	0° to 50° C (32° to 122° F)
Storage Temperature	-50° to 75° C (-58° to 167° F)	Storage Temperature	-50° to 75° C (-58° to 167° F)
Humidity	Up to 90% (non-condensing)	Humidity	Up to 90% (non-condensing)

**Emissions**

MS-860		QX-870	
Heavy Industrial	EN 61000-6-2:2001	Heavy industrial	EN 61000-6-2:2005
Radiated and Conducted Emissions	EN 55022:1998 + A1:2000 + A2:2003 (Limits and Methods: ITE Disturbances) General Immunity residential: EN55024:1998 + A1:2001 + A2:2003	Radiated emissions	EN 55022:2006 Class A 30-1000 MHz
		Conducted emissions	EN 55022:2006 Class A .15-30 MHz

**Laser Light**

MS-860		QX-870	
Type	Semiconductor visible laser diode (650 nm nominal)	Type	Laser diode (650 nm nominal)
Operating Life	50,000 hours @ 25° C	Operating Life	50,000 hours @ 25° C
Safety Class	CDRH Class II	Safety Class	Visible laser: Class 2

**Communication**

MS-860		QX-870	
Interfaces	RS-232, RS-422/485, AUX Port	Interfaces	RS-232, RS-422/485, Ethernet TCP/IP, EtherNet I/P

**Symbologies**

MS-860		QX-870	
Symbologies	Standard Offering: Code 128, Code 39, Code 93, Codabar, GS1 Databar (RSS), Interleaved 2 of 5, UPC/EAN, PDF417, MicroPDF, Pharmacode	Symbologies	Standard Offering: Code 39, Codabar, Code 93, Interleaved 2 of 5, Code 128, PDF417, MicroPDF417, Pharmacode, UPC, GS1 Databar Applications Standards: UCC/EAN-128, AIAG

*MS-860-to-QX-870 Industrial Raster Scanner Transition Guide*

**Scanning Parameters**

<b>MS-860</b>		<b>QX-870</b>	
<b>Mirror Type</b>	Rotating, 10-faceted	<b>Mirror Type</b>	Rotating, 10-faceted
<b>Scan Rate</b>	Adjustable from 300 to 1200 scans/second (Default = 500 sps)	<b>Scan Rate</b>	Adjustable from 300 to 1400 scans/second
<b>Scan Width Angle</b>	Typically 60°	<b>Scan Width Angle</b>	Typically 60°
<b>Pitch</b>	±50° maximum	<b>Pitch</b>	±50° maximum
<b>Skew</b>	±40° maximum	<b>Skew</b>	±40° maximum
<b>Symbol Contrast</b>	25% min. absolute dark to light differential at 650 nm wavelength	<b>Symbol Contrast</b>	25% min. absolute dark to light differential at 655 nm wavelength
<b>Raster Mirror Performance</b>	80 sweeps per second at 1° - 10° sweep angle 60 sweeps per second at 11° - 20° sweep angle 40 sweeps per second at 21° - 34° (max.) sweep angle 20 sweeps per second at 35° - 36° (max.) sweep angle	<b>Raster Mirror Performance</b>	80 sweeps per second at 1° - 10° sweep angle 60 sweeps per second at 11° - 20° sweep angle 40 sweeps per second at 21° - 34° (max.) sweep angle 20 sweeps per second at 35° - 36° (max.) sweep angle

**Electrical**

<b>MS-860</b>		<b>QX-870</b>	
<b>Power Requirement</b>	10-28 VDC, 200 mV p-p max. ripple, 110 mA at 24 VDC (typ.)	<b>Power Requirement</b>	10-28 VDC, 200 mV p-p max. ripple, 270 mA at 24 VDC (typ.)
<b>Trigger, New Master, Input 1</b>	Optoisolated, 5-28V rated, (12 mA at 24 VDC)	<b>Trigger, New Master, Input 1</b>	Optoisolated, 4.5-28V rated, (13 mA at 24 VDC) New Master and Input 1 share the input common line.
<b>Output 1, 2, 3</b>	Optoisolated, 1-28 VDC rated, (I <sub>CE</sub> <100 mA at 24 VDC, current limited by user)	<b>Output 1, 2, 3</b>	Optoisolated, 1-28 VDC rated, (I <sub>CE</sub> <100 mA at 24 VDC, current limited by user)
<b>Default</b>	Internally tied PWR+. Use PWR- to activate.	<b>Default</b>	Internally tied PWR+. Use PWR- to activate.

**Safety Certifications**

<b>MS-860</b>		<b>QX-870</b>	
<b>Certifications</b>	CDRH, CE, UL/cUL, RoHS	<b>Certifications</b>	CDRH, FCC, CE, CB, BSMI (compliant)

MS-860-to-QX-870 Industrial Raster Scanner Transition Guide

**MS-860 Host Connector Pin Assignments (25-pin D-Subminiature Plug)**

Pin No.	Host RS-232	Host/Aux. RS-232	Host RS-422/485	In/Out
1	Chassis Ground			
2	TxD			Out
3	RxD			In
4	RTS	Aux TxD		Out
5	CTS	Aux TxD		In
6	Output 1 (+)			Out
7	Signal Ground			
8	Output 2 (+)			Out
9	Trigger (-)			In
10	Trigger (+)			In
11	Default configuration (Activated by connecting pin 11 to ground pin 7)			In
12	Input 1 (+)			In
13			RxD (+)	In
14			TxD (-)	Out
15	No Read / Output 3 (+)			Out
16			RxD (-)	In
17	Power Ground			In
18	Power +10 to 28 VDC			In
19			TxD (+)	Out
20	Output 1 (-)			Out
21	Output 2 (-)			Out
22	No Read / Output 3 (-)			Out
23	Input 1 (-)			In
24	New master (-)			In
25	New master (+)			In

**MS-860 Trigger Connector Pin Assignments (4-pin MicroChange)**

Pin No.	Function	In/Out
1	Power + 10 to 28 VDC	Out
2	Trigger (-)	
3	Power Ground (Used for power return only)	
4	Trigger (+)	

**MS-860 Power Connector Pin Assignments (3-pin MicroChange)**

Pin No.	Function	In/Out
1	Power Ground	
2	NC	
3	Power + 10 to 28 VDC	In

MS-860-to-QX-870 Industrial Raster Scanner Transition Guide

**QX-870 Pin Assignments**

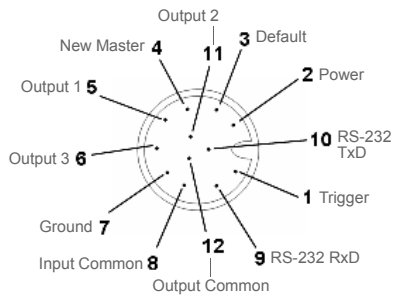

**Connector A (Serial)  
M12 12-pin Plug**

1	Trigger
2	Power
3	Default
4	New Master
5	Output 1
6	Output 3
7	Ground
8	Input Common
9	Host RxD
10	Host TxD
11	Output 2
12	Output Common

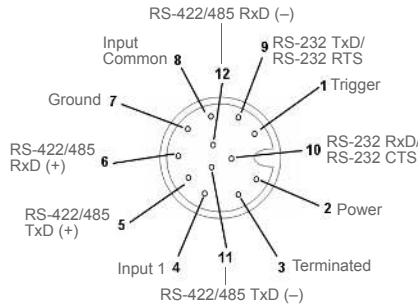

**Connector B (Serial)  
M12 12-pin Socket**

1	Trigger
2	Power
3	Terminated
4	Input 1
5	Port 3 422/485 TxD (+)
6	Port 3 422/485 RxD (+)
7	Ground
8	Input Common
9	Port 2 TxD/Port 1 RTS
10	Port 2 RxD/Port 1 CTS
11	Port 3 422/485 TxD (-)
12	Port 3 422/485 RxD (-)

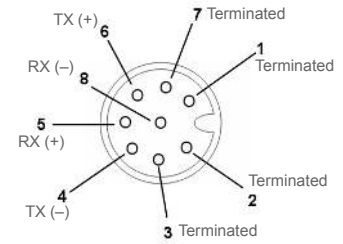

**Connector B (Ethernet)  
M12 8-pin Socket**

1	Terminated
2	Terminated
3	Terminated
4	Port 4 TX (-)
5	Port 4 RX (+)
6	Port 4 TX (+)
7	Terminated
8	Port 4 RX (-)

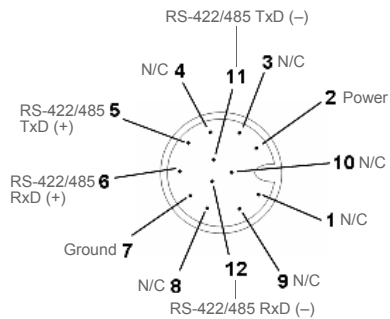

**Connector P/M (Serial)  
M12 12-pin Plug**

1	N/C
2	Power
3	N/C
4	N/C
5	422/485 TxD (+)
6	422/485 RxD (+)
7	Ground
8	N/C
9	N/C
10	N/C
11	422/485 TxD (-)
12	422/485 RxD (-)

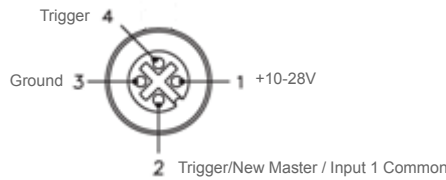

**Connector T (Trigger)  
M12 4-pin Socket**

1	+10 to 28 V
2	Trigger/New Master/Input 1 Common
3	Ground
4	Trigger

**For Assistance, contact the Automation Group at Cross 800.866.4568**

---

*MS-860-to-QX-870 Industrial Raster Scanner Transition Guide*