

Cross Antenna Position Control System

Improve control, repeatability, and flexibility with an automated antenna position control system.

Antenna positioning or pointing systems require precision control to reliably and accurately hit, or track, their intended target. Manually controlled systems can be cumbersome to setup, work within a limited range of motion, and are less likely to provide the level of control and repeatability necessary for such complex systems. Manually adjusted “lock In place” systems are labor intensive to adjust and offer fixed angular positions that are defined at the time of initial design and manufacture. By implementing a coordinated motion control system for antenna positioning, the system gains a tremendous amount of control and flexibility.

The motion control experts at Cross Company have streamlined this application by designing a standard but configurable Antenna Position Control System using industrial grade controls and mechanics. The electromechanical system includes a base X axis to provide linear travel and an azimuth, or tilt, axis for angular adjustments.

The X axis uses a dual axis belt driven actuator system coupled via a linkshaft. The tilt axis uses a rod style ballscrew actuator with the rod end fixed to the underside of the antenna mounting plate. Both axis are driven by stepper motors. The entire system is connected using custom mounting plates that allow the tilt axis to ride on the carriages of the X axis.

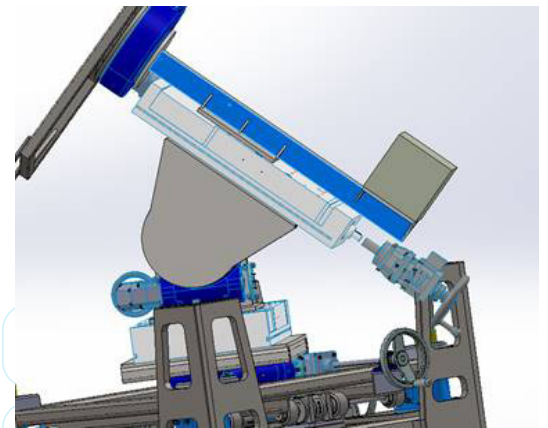

This two axis system gives the flexibility to move an antenna to any position along a single linear axis with the desired azimuth position on the tilt axis. Using a stepper or servo control system gives the ability to move the antenna to any linear and azimuth position with a few keystrokes into a PC or user interface. This allows measurements to be taken with greater speed and accuracy, resulting in reduced testing time and optimal positioning.

The type of control method can range from simple jogging or indexing, all the way up to a fully-automated closed loop system continuously monitoring signal feedback to adjust position.

The Antenna Position Control System is a standard but configurable system that can be tailored to meet the individual requirements of each application. Systems are configured to handle the load requirements, length of travel, degree of tilt, geometric constraints, environmental conditions, motion profiles, project budget, and more.

Key features of the Cross Antenna Position Control System:

- Configurable system - stroke length, overall width, tilt angle, load capacity, and mounting/mechanical sub-assemblies
- Better target precision due to increased range of motion and adjustability
- Stepper or servo system is open to various control methods, from simple to complex.
- Reduced testing time and overall ease of use
- Cross engineering support from start to finish

Components included in this customizable system:

- Base X axis - Two belt-driven actuators that provide linear positioning to the antenna system and azimuth (tilt) axis.
- Azimuth (tilt) axis – A rod style screw-driven actuator mounted to the carriages via a crossmember bracket
- Stepper/servo motor control system to meet application requirements
- Closed pillow blocks bearings that ride on a precision radial shaft and provide the axis of rotation for tilting the steel plate mounted antenna
- Sub-assembly including adapter plates, linkages, nuts and bolts

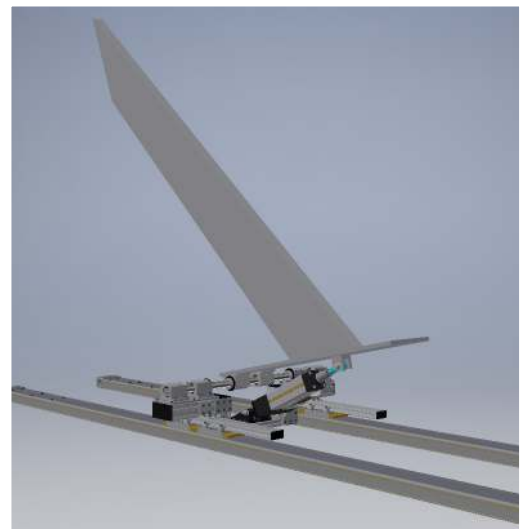

Systems are modeled in CAD and design reviews with clients take place throughout the process. Offering standard but configurable systems like the Antenna Position Control System is how the experts at Cross Company can help you “make motion work”.